



**STANDARD
SPECIFICATIONS
FOR CONSTRUCTION
AND MAINTENANCE OF
HIGHWAYS, STREETS,
AND BRIDGES**

**Adopted by the
Texas Department of Transportation**

June 1, 2004

Published in June 2004. This document has been created to further the purposes of §201.053(b)(7) Texas Transportation Code to maximize federal funding for highways, public transportation, and aviation purposes, and to help the Department achieve its performance measures set out in the General Appropriations Act, H.B. 1, 76th Legislature, Regular Session. This publication has been filed with the State Publications Clearinghouse in the State Library in accordance with the Texas State Depository Law.



Foreword

To purchase a copy of this book, go to TxDOT's web page, <http://www.dot.state.tx.us>, General Services Division or call TxDOT's General Services Division.

For additional information on specifications and updates or information on Departmental Material Specifications (DMS), Manual of Testing Procedures, Material Inspection Guide and other material information go to <http://www.dot.state.tx.us>.

Outline of Specifications

Each specification is outlined by Articles and Sections. The basic Articles required for a specification are:

XXX.1. Description.

XXX.2. Materials.

XXX.3. Equipment.

XXX.4. Construction or Work Methods.

XXX.5. Measurement.

XXX.6. Payment.

Here "XXX" represents the Item number. Some Articles are not used in every Item. Measurement and Payment Articles are combined when the work described is subsidiary to bid items of the Contract.

Hierarchy of Organizational Elements

The hierarchy of organizational elements available below the Item level is as follows:

XXX.X. Article.

A. Section.

1. Section.

a. Section.

(1) Section.

(a) Section.

The term Section is used for all breaks below the Article.

TABLE OF CONTENTS

ITEMS 1-9 **General Requirements and Covenants**

ITEM	1.	Definition of Terms	1
	2.	Instructions to Bidders.....	16
	3.	Award and Execution of Contract.....	25
	4.	Scope of Work	28
	5.	Control of the Work.....	32
	6.	Control of Materials.....	38
	7.	Legal Relations and Responsibilities	42
	8.	Prosecution and Progress	56
	9.	Measurement and Payment.....	66

100 ITEMS **Earth Work and Landscape**

ITEM	100.	Preparing Right of Way	75
	103.	Disposal of Wells.....	76
	104.	Removing Concrete	78
	105.	Removing Stabilized Base and Asphalt Pavement	79
	106.	Obliterating Abandoned Road	80
	110.	Excavation	80
	112.	Subgrade Widening.....	82
	132.	Embankment	83
	134.	Backfilling Pavement Edges	89
	150.	Blading.....	90
	152.	Road Grader Work.....	91
	154.	Scraper Work	92
	156.	Bulldozer Work	93
	158.	Specialized Excavation Work	94
	160.	Topsoil	95
	161.	Compost.....	98
	162.	Sodding for Erosion Control.....	101
	164.	Seeding for Erosion Control	103
	166.	Fertilizer.....	115
	168.	Vegetative Watering	116
	169.	Soil Retention Blankets	117
	170.	Irrigation System	118
	180.	Wildflower Seeding.....	121
	192.	Landscape Planting.....	122
	193.	Landscape Establishment.....	128

TABLE OF CONTENTS (continued)

200 ITEMS Subgrade Treatments and Base

ITEM	204.	Sprinkling.....	133
	210.	Rolling	133
	216.	Proof Rolling.....	138
	247.	Flexible Base.....	138
	251.	Reworking Base Courses	146
	260.	Lime Treatment (Road-Mixed).....	152
	263.	Lime Treatment (Plant-Mixed).....	159
	265.	Fly Ash or Lime—Fly Ash Treatment (Road-Mixed).....	166
	275.	Cement Treatment (Road-Mixed).....	174
	276.	Cement Treatment (Plant-Mixed)	180
	292.	Asphalt Treatment (Plant-Mixed).....	186

300 ITEMS Surface Courses and Pavement

ITEM	300.	Asphalts, Oils, and Emulsions	199
	301.	Asphalt Antistripping Agents.....	215
	302.	Aggregates for Surface Treatments.....	218
	305.	Salvaging, Hauling, and Stockpiling Reclaimable Asphalt Pavement	222
	310.	Prime Coat	223
	314.	Emulsified Asphalt Treatment	224
	315.	Fog Seal	225
	316.	Surface Treatments	226
	318.	Hot Asphalt-Rubber Surface Treatments	232
	320.	Equipment for Asphalt Concrete Pavement.....	237
	330.	Limestone Rock Asphalt Pavement	242
	334.	Hot-Mix Cold-Laid Asphalt Concrete Pavement.....	255
	340.	Dense-Graded Hot-Mix Asphalt (Method)	265
	341.	Dense-Graded Hot-Mix Asphalt (QC/QA)	278
	342.	Permeable Friction Course (PFC)	312
	344.	Performance-Designed Mixtures	329
	346.	Stone-Matrix Asphalt.....	364
	350.	Microsurfacing.....	398
	351.	Flexible Pavement Structure Repair.....	405
	354.	Planing and Texturing Pavement	408
	356.	Fabric Underseal	410

TABLE OF CONTENTS (continued)

358.	Asphalt Concrete Surface Rehabilitation	413
360.	Concrete Pavement	416
361.	Full-Depth Repair of Concrete Pavement	432
368.	Concrete Pavement Terminals	434

400 ITEMS Structures

ITEM	400.	Excavation and Backfill for Structures	437
	401.	Flowable Backfill	450
	402.	Trench Excavation Protection	452
	403.	Temporary Special Shoring	453
	404.	Driving Piling	454
	405.	Foundation Test Load	462
	406.	Timber Piling	463
	407.	Steel Piling	465
	409.	Prestressed Concrete Piling	470
	416.	Drilled Shaft Foundations	472
	420.	Concrete Structures	482
	421.	Hydraulic Cement Concrete	516
	422.	Reinforced Concrete Slab	535
	423.	Retaining Walls	537
	424.	Precast Concrete Structures (Fabrication)	547
	425.	Precast Prestressed Concrete Structural Members	572
	426.	Prestressing	575
	427.	Surface Finishes for Concrete	593
	428.	Concrete Surface Treatment	601
	429.	Concrete Structure Repair	603
	430.	Extending Concrete Structures	608
	431.	Pneumatically Placed Concrete	610
	432.	Riprap	616
	434.	Elastomeric Bridge Bearings	627
	438.	Cleaning and Sealing Joints and Cracks (Rigid Pavement and Bridge Decks)	634
	439.	Concrete Bridge Deck Overlays	636
	440.	Reinforcing Steel	643
	441.	Steel Structures	653
	442.	Metal for Structures	672
	445.	Galvanizing	678
	446.	Cleaning and Painting Steel	682
	447.	Structural Bolting	702

TABLE OF CONTENTS (continued)

448.	Structural Field Welding.....	708
449.	Anchor Bolts	729
450.	Railing.....	734
452.	Removing Railing	737
453.	Temporary Railing	738
454.	Bridge Expansion Joints	739
458.	Waterproofing Membranes for Structures.....	742
459.	Gabions and Gabion Mattresses.....	747
460.	Corrugated Metal Pipe	751
461.	Structural Plate Structures.....	760
462.	Concrete Box Culverts and Storm Drains	765
464.	Reinforced Concrete Pipe	770
465.	Manholes and Inlets	778
466.	Headwalls and Wingwalls.....	782
467.	Safety End Treatment	785
471.	Frames, Grates, Rings, and Covers	789
472.	Removing and Re-Laying Culvert and Storm Drain Pipe	790
473.	Laying Culvert and Storm Drain Pipe.....	792
474.	Slotted Drain	793
476.	Jacking, Boring, or Tunneling Pipe or Box.....	794
479.	Adjusting Manholes and Inlets	798
480.	Cleaning Existing Culverts	799
481.	PVC Pipe for Drains	800
483.	Scarifying Concrete Bridge Slab.....	801
490.	Timber Structures.....	802
491.	Timber for Structures	804
492.	Timber Preservative and Treatment	805
495.	Raising Existing Structures.....	807
496.	Removing Structures.....	809
497.	Sale of Salvageable Material.....	810
499.	Adjusting Steel Shoes	811

500 ITEMS Miscellaneous Construction

ITEM	500.	Mobilization.....	813
	502.	Barricades, Signs, and Traffic Handling.....	814
	504.	Field Office and Laboratory.....	816
	506.	Temporary Erosion, Sedimentation, and Environmental Controls	820

TABLE OF CONTENTS (continued)

508.	Constructing Detours	834
510.	One-Way Traffic Control.....	836
512.	Portable Concrete Traffic Barrier	837
514.	Permanent Concrete Traffic Barrier.....	839
520.	Weighing and Measuring Equipment	842
528.	Colored Textured Concrete and Landscape Pavers	844
529.	Concrete Curb, Gutter, and Combined Curb and Gutter	848
530.	Intersections, Driveways, and Turnouts.....	850
531.	Sidewalks.....	851
533.	Shoulder Texturing	853
536.	Concrete Medians and Directional Islands	854
538.	Right of Way Markers	855
540.	Metal Beam Guard Fence	856
542.	Removing Metal Beam Guard Fence.....	860
544.	Guardrail End Treatments.....	862
545.	Crash Cushion Attenuators	863
550.	Chain Link Fence.....	864
552.	Wire Fence.....	871
556.	Pipe Underdrains	873
560.	Mailbox Assemblies	877
585.	Ride Quality for Pavement Surfaces.....	878

600 ITEMS **Lighting, Signing, Markings, and Signals**

ITEM	610.	Roadway Illumination Assemblies	887
	613.	High Mast Illumination Poles	890
	614.	High Mast Illumination Assemblies	894
	616.	Performance Testing of Lighting Systems.....	896
	617.	Temporary Roadway Illumination	896
	618.	Conduit	898
	620.	Electrical Conductors.....	901
	621.	Tray Cable	902
	622.	Duct Cable	903
	624.	Ground Boxes	905
	625.	Zinc-Coated Steel Wire Strand.....	906
	627.	Treated Timber Poles.....	907
	628.	Electrical Services.....	909
	634.	Plywood Signs	911

TABLE OF CONTENTS (continued)

636.	Aluminum Signs	914
643.	Sign Identification Decals	918
644.	Small Roadside Sign Supports and Assemblies	920
647.	Large Roadside Sign Supports and Assemblies	922
650.	Overhead Sign Supports	925
652.	Highway Sign Lighting Fixtures	930
654.	Sign Walkways	931
656.	Foundations for Traffic Control Devices	933
658.	Delineator and Object Marker Assemblies	935
662.	Work Zone Pavement Markings	937
666.	Reflectorized Pavement Markings	939
668.	Prefabricated Pavement Markings	944
672.	Raised Pavement Markers	947
677.	Eliminating Existing Pavement Markings and Markers	949
678.	Pavement Surface Preparation for Markings	951
680.	Installation of Highway Traffic Signals	952
681.	Temporary Traffic Signals	956
682.	Vehicle and Pedestrian Signal Heads	957
684.	Traffic Signal Cables	959
685.	Roadside Flashing Beacon Assemblies	962
686.	Traffic Signal Pole Assemblies (Steel)	965
687.	Pedestal Pole Assemblies	969
688.	Pedestrian Detectors and Vehicle Loop Detectors	970
690.	Maintenance of Traffic Signals	973

700 ITEMS Maintenance

ITEM	700.	Pothole Repair	981
	712.	Cleaning and Sealing Joints and Cracks (Asphalt Concrete)	982
	720.	Repair of Spalling in Concrete Pavement	984
	730.	Roadside Mowing	985
	734.	Litter Removal	987
	735.	Debris Removal	988
	738.	Cleaning and Sweeping Highways	989
	740.	Graffiti Removal and Anti-Graffiti Coating	991
	745.	Picnic and Rest Area Maintenance	993
	751.	Landscape Maintenance	997
	752.	Tree and Brush Removal	999

TABLE OF CONTENTS (continued)

760.	Cleaning and Reshaping Ditches	1001
764.	Pump Station and Drainage System Cleaning	1001
770.	Guard Fence Repair	1003
772.	Post and Cable Fence	1006
774.	Attenuator Repair.....	1008
776.	Metal Rail Repair.....	1009
780.	Epoxy Injection.....	1010
784.	Repairing Steel Bridge Members.....	1012
788.	Concrete Beam Repair	1015

ITEMS 1-9 — GENERAL REQUIREMENTS AND COVENANTS

ITEM 1

DEFINITION OF TERMS

1.1. Applicability. Wherever the following terms are used in these specifications or other Contract documents, the intent and meaning will be interpreted as shown below.

1.2. Abbreviations:

AAR	Association of American Railroads
AASHTO	American Association of State Highway and Transportation Officials
ACI	American Concrete Institute
ACPA	American Concrete Pipe Association
AI	Asphalt Institute
AIA	American Institute of Architects
AISC	American Institute of Steel Construction
AISI	American Iron and Steel Institute
AITC	American Institute of Timber Construction
ALSA	American Lumber Standard Committee, Inc.
AMRL	AASHTO Materials Reference Laboratory
ANLA	American Nursery and Landscape Association
ANSI	American National Standards Institute
APA	APA-The Engineered Wood Association
API	American Petroleum Institute
APWA	American Public Works Association
AREMA	American Railway Engineering and Maintenance-of-Way Association
ASBI	American Segmental Bridge Institute
ASCE	American Society of Civil Engineers
ASLA	American Society of Landscape Architects
ASME	American Society of Mechanical Engineers
ASNT	American Society for Nondestructive Testing
ASTM	American Society for Testing and Materials
AWC	American Wood Council
AWG	American Wire Gage
AWPA	American Wood-Preservers' Association
AWPI	American Wood Preservers Institute
AWS	American Welding Society
AWWA	American Water Works Association

1.2 to 1.2

BMP	Best Management Practices
CFR	Code of Federal Regulations
CMP	Corrugated Metal Pipe
COE	U.S. Army Corps of Engineers
CRSI	Concrete Reinforcing Steel Institute
DMS	Departmental Material Specification
EIA	Electronic Industries Alliance
EPA	United States Environmental Protection Agency
FHWA	Federal Highway Administration, U.S. Department of Transportation
FSS	Federal Specifications and Standards (General Services Administration)
GSA	General Services Administration
ICEA	Insulated Cable Engineers Association
IEEE	Institute of Electrical and Electronics Engineers
IESNA	Illuminating Engineering Society of North America
IMSA	International Municipal Signal Association
ISO	International Organization for Standardization
ITE	Institute of Transportation Engineers
LRFD	Load Resistance Factor Design
MIL	Military Specifications
NCHRP	National Cooperative Highway Research Program
NEC	National Electrical Code (Published by NFPA)
NEMA	National Electrical Manufacturers Association
NEPA	National Environmental Policy Act
NESC	National Electrical Safety Code
NFPA	National Fire Protection Association
NIST	National Institute of Standards and Technology
NRMCA	National Ready Mixed Concrete Association
NSBA	National Steel Bridge Alliance
OSHA	Occupational Safety & Health Administration, U.S. Department of Labor
PCA	Portland Cement Association
PCI	Precast/Prestressed Concrete Institute
PSI	Pounds Per Square Inch
PPI	Plastics Pipe Institute
PS&E	Plans, Specifications, and Estimate
RCP	Reinforced Concrete Pipe
RPLS	Registered Public Land Surveyor
RRC	Railroad Commission of Texas
SAE	Society of Automotive Engineers
SFPA	Southern Forest Products Association

SI	International System of Units
SPIB	Southern Pine Inspection Bureau
SSPC	The Society for Protective Coatings
TAC	Texas Administrative Code
TCEQ	Texas Commission on Environmental Quality
TDLR	Texas Department of Licensing and Regulation
TMUTCD	Texas Manual on Uniform Traffic Control Devices for Streets and Highways
UL	Underwriters Laboratory, Inc.
USC	United States Code
WRI	Wire Reinforcement Institute
WWPA	Western Wood Products Association

1.3. A+B Bidding. A cost-plus-time bidding procedure.

1.4. Abrasive Blasting. Spraying blasts of pressurized air combined with abrasive media.

1.5. Actual Cost. Contractor's actual cost to provide labor, material, equipment, and project overhead necessary for the work.

1.6. Addendum. Change in proposal forms developed between advertising and bid submittal deadline.

1.7. Advertisement. The public announcement required by law inviting bids for work to be performed or materials to be furnished.

1.8. Air Blasting. Spraying blasts of pressurized air free of oil and moisture.

1.9. Air Temperature. The temperature measured in degrees Fahrenheit (°F) in the shade, not in the direct rays of the sun, and away from artificial heat.

1.10. Anticipated Profit. Profit for work not performed.

1.11. Apparent Low Bidder. The Bidder determined to have the numerically lowest total bid as a result of the tabulation of bids by the Department.

1.12. Architect of Record. A person registered as an architect or licensed as a landscape architect, in accordance with State law, exercising overall responsibility for the design or a significant portion of the design and

1.12 to 1.23

performs certain Contract administration responsibilities as described in the Contract; or a firm employed by the State to provide professional architectural services.

1.13. Arterial Highway. A highway used primarily for through traffic and usually on a continuous route.

1.14. Available Bidding Capacity. The Contractor's approved bidding capacity less uncompleted work on Department Contracts.

1.15. Award. The Commission's acceptance of a Contractor's bid for a proposed Contract that authorizes the Department to enter into a Contract.

1.16. Bid Bond. The security executed by the Contractor and the Surety furnished to the Department to guarantee payment of liquidated damages if the Contractor fails to enter into an awarded Contract.

1.17. Bid Error. A mathematical mistake made by the prime Contractor in the unit price entered into the proposal.

1.18. Bidder. An individual, partnership, limited liability company, corporation, or joint venture submitting a bid for a proposed Contract.

1.19. Bidders Questionnaire. A prequalification form completed by a prospective Bidder reflecting a Bidder's financial data and experience.

1.20. Bidding Capacity. The maximum dollar value a Contractor may have under Contract with the Department at any given time.

1.21. Blast Cleaning. Using 1 of the blasting methods including, but not limited to, water blasting, low-pressure water blasting, high-pressure water blasting, abrasive blasting, water-abrasive blasting, shot blasting, slurry blasting, water injected abrasive blasting, and brush blasting.

1.22. Bridge. A structure, including supports, erected over a depression or an obstruction (e.g., water, a highway, or a railway) having a roadway or track for carrying traffic or other moving loads, and having an opening measured along the center of the roadway of more than 20 ft. between faces of abutments, spring lines of arches, or extreme ends of the openings for multiple box culverts.

1.23. Brush Blasting. Sweeping lightly with an abrasive blast to remove loose material.

1.24. Building Contract. A Contract entered under Transportation Code, Chapter 223, Subchapter A, “Competitive Bids,” for the construction or maintenance of a Department building or appurtenance facilities. Building Contracts are considered to be construction Contracts.

1.25. Callout Work. Contracts, or work items in Contracts, that require a Contractor’s response on an as-needed basis (e.g., see Item 351, “Flexible Pavement Structure Repair”).

1.26. Certificate of Insurance. A form approved by the Department covering insurance requirements stated in the Contract.

1.27. Change Order. Written order to the Contractor detailing changes to the specified work, item quantities or any other modification to the Contract.

1.28. Commission. The Texas Transportation Commission or authorized representative.

1.29. Construction Bulletin C-8. Manual of procedures for driving and test loading piling.

1.30. Construction Bulletin C-9. Manual of procedures for constructing and test loading drilled shafts.

1.31. Construction Contract. A Contract entered under Transportation Code, Chapter 223, Subchapter A, for the construction, reconstruction, or maintenance of a segment of the State highway system.

1.32. Consultant. The licensed professional engineer or engineering firm, or the architect or architectural firm, registered in the State of Texas and under Contract to the Department to perform professional services. The consultant may be the Engineer or architect of record or may provide services through and be subcontracted to the Engineer or architect of record.

1.33. Contract. The agreement between the Department and the Contractor establishing the obligations of the parties for furnishing of materials and performance of the work prescribed in the Contract documents.

1.34. Contract Documents. Elements of the Contract including but not limited to the plans, specifications incorporated by reference, special provisions, special specifications, Contract bonds, change orders, and supplemental agreements.

1.35 to 1.47

1.35. Contract Time. The number of working days specified for completion of the work including authorized additional working days.

1.36. Contractor. The individual, partnership, limited liability company, corporation, or joint venture and all principals and representatives with which the Contract is made by the Department.

1.37. Controlled Access Highway. Any highway to or from which access is denied or controlled, in whole or in part, from or to abutting land or intersecting streets, roads, highways, alleys, or other public or private ways.

1.38. Control of Access. The condition in which the right to access of owners or occupants of abutting land or other persons in connection with a highway is fully or partially controlled by public authority.

1.39. Control Point. An established point shown on the plans to provide vertical and horizontal references for geometric control for construction.

1.40. Cross-Sections. Graphic representations of the original ground and the proposed facility, at right angles to the centerline or base line.

1.41. Culvert. Any buried structure providing an opening under a roadway for drainage or other purposes. Culverts may also be classified as bridges. (See Article 1.22, “Bridge.”)

1.42. Cycle. The activity necessary for performing the specified work within the right of way project limits once.

1.43. Daily Road-User Cost. Damages based on the estimated daily cost of inconvenience to the traveling public resulting from the work.

1.44. Date of Written Authorization. Date of the written work order authorizing the Contractor to begin work.

1.45. Debar (Debarment). Action taken by the Department or federal government pursuant to regulation that prohibits a person or company from entering into a Contract, or from participating as a subcontractor, or supplier of materials or equipment used in a highway improvement Contract as defined in Transportation Code, Chapter 223, Subchapter A.

1.46. Detour. A temporary traffic route around a closed portion of a road.

1.47. Department. The Texas Department of Transportation (TxDOT).

1.48. Departmental Material Specifications (DMS). Reference specifications for various materials published by the Construction Division.

1.49. Direct Traffic Culvert. Concrete box culvert whose top slab is used as the final riding surface or is to have an overlay or other riding surface treatment.

1.50. Disadvantaged Business Enterprise (DBE). A small business, certified by the Department, that is 51% owned by 1 or more minorities or women, or in the case of a publicly owned business, at least 51% of the stock is owned by 1 or more minorities or women, and whose management and daily business operations are controlled by 1 or more of these individuals.

1.51. Divided Highway. A highway with separate roadways intended to move traffic in opposite directions.

1.52. Easement. A real property right acquired by 1 party to use land belonging to another party for a specified purpose.

1.53. Engineer. The Executive Director of the Department or the authorized representative of the Executive Director.

1.54. Expressway. A divided arterial highway for through traffic with full or partial control of access and generally with grade separations at intersections

1.55. Force Account. Payment for directed work based on the actual cost of labor, equipment, and materials furnished with markups for project overhead and profit.

1.56. Freeway. An expressway with full control of access.

1.57. Frontage Road. A local street or road auxiliary to and located along an arterial highway for service to abutting property and adjacent areas and for control of access (sometimes known as a service road, access road, or insulator road).

1.58. Hazardous Materials or Waste. Hazardous materials or waste include but are not limited to explosives, compressed gas, flammable liquids, flammable solids, combustible liquids, oxidizers, poisons, radioactive materials, corrosives, etiologic agents, and other material

1.58 to 1.65

classified as hazardous by 40 CFR 261, or applicable state and federal regulations.

1.59. High-Pressure Water Blasting. Water blasting with pressures between 5,000 and 10,000 psi.

1.60. Highway, Street, or Road. General terms denoting a public way for purposes of vehicular travel, including the entire area within the right of way. Recommended usage in urban areas is highway or street; in rural areas, highway or road.

1.61. Historically Underutilized Business (HUB). A corporation, sole proprietorship, partnership, or joint venture formed for the purpose of making a profit certified by the Texas Building and Procurement Commission, and 51% owned by 1 or more persons who are economically disadvantaged because of their identification as members of certain groups, including African Americans, Hispanic Americans, Asian-Pacific Americans, Native Americans, or women, and have a proportionate interest and demonstrate active participation in the control, operation, and management of the business' affairs. Individuals meeting the HUB definition are required to be residents of the State of Texas. Businesses that do not have their primary headquarters in the State of Texas are not eligible for HUB certification.

1.62. Incentive/Disincentive Provisions. An adjustment to the Contract price of a predetermined amount for each day the work is completed ahead of or behind the specified milestone, phase, or Contract completion dates. The amount of the incentive/disincentive is determined based on estimated costs for engineering, traffic control, delays to the motorists, and other items involved in the Contract.

1.63. Independent Assurance Tests. Tests used to evaluate the sampling and testing techniques and equipment used in the acceptance program. The tests are performed by the Department and are not used for acceptance purposes.

1.64. Inspector. The person assigned by the Engineer to inspect for compliance with the Contract any or all parts of the work and the materials used.

1.65. Intersection. The general area where 2 or more highways, streets, or roads join or cross, including the roadway and roadside facilities for traffic movements within it.

1.66. Island. An area within a roadway from which vehicular traffic is intended to be excluded, together with any area at the approach occupied by protective deflecting or warning devices.

1.67. Joint venture. Any combination of individuals, partnerships, limited liability companies, or corporations submitting a single bid proposal.

1.68. Lane Rental. A method to assess the Contractor daily or hourly rental fees for each lane, shoulder, or combination of lanes and shoulders taken out of service.

1.69. Letting. The receipt, opening, tabulation, and determination of the apparent low Bidder.

1.70. Letting Official. The Executive Director or any Department employee empowered by the Executive Director to officially receive bids and close the receipt of bids at a letting.

1.71. Licensed Professional Engineer. A person who has been duly licensed by the Texas Board of Professional Engineers to engage in the practice of engineering in the State of Texas; also referred to as a Professional Engineer.

1.72. Limits of Construction. An area with established boundaries, identified within the highway right of way and easements, where the Contractor is permitted to perform the work.

1.73. Local Street or Road. A street or road primarily for access to residence, business, or other abutting property.

1.74. Low-Pressure Water Blasting. Water blasting with pressures between 3,000 and 5,000 psi.

1.75. Major Item. An item of work included in the Contract that has a total cost equal to or greater than 5% of the original Contract or \$100,000 whichever is less.

1.76. Manual of Testing Procedures. Department manual outlining test methods and procedures maintained by the Materials and Pavements Section of the Construction Division.

1.77 to 1.88

1.77. Materially Unbalanced Bid. A bid that generates a reasonable doubt that award to the Bidder submitting a mathematically unbalanced bid will result in the lowest ultimate cost to the State.

1.78. Mathematically Unbalanced Bid. A bid containing bid prices that do not reflect reasonable actual costs plus a reasonable proportionate share of the Bidder's anticipated profit, overhead costs, and other indirect costs.

1.79. Median. The portion of a divided highway separating the traffic lanes in opposite directions.

1.80. Milestone Date. The date that a specific portion of the work is to be completed, before the completion date for all work under the Contract.

1.81. Multiple Work Order Contracts. Contracts with recurring maintenance or non-site-specific work.

1.82. National Holiday. January 1, the last Monday in May, July 4, the first Monday in September, the fourth Thursday in November, December 24, or December 25.

1.83. Nonhazardous Recyclable Material (NRM). A material recovered or diverted from the nonhazardous waste stream for the purposes of reuse or recycling in the manufacture of products that may otherwise be produced using raw or virgin materials.

1.84. Nonresident Bidder. A Bidder whose principal place of business is not in Texas. This includes a Bidder whose ultimate parent company or majority owner does not have its principal place of business in Texas.

1.85. Nonresponsive Proposal. A proposal that does not meet the criteria for acceptance contained in the proposal form.

1.86. Non-Site-Specific Contracts. Contracts in which a geographic region is specified for the work and for which work orders, with or without plans, further detail the limits and work to be performed.

1.87. Notification. Either written or oral instruction to the Contractor concerning the work. Voice mail is oral notification.

1.88. Pavement. That part of the roadway having a constructed surface for the use of vehicular traffic.

1.89. Pavement Structure. Combination of surface course and base course placed on a subgrade to support the traffic load and distribute it to the roadbed.

- A. Surface Course.** Pavement structure layers designed to accommodate the traffic load. The top layer resists skidding, traffic abrasion, and the disintegrating effects of climate and is sometimes called the wearing course.
- B. Base Course.** One or more layers of specified material thickness placed on a subgrade to support a surface course.
- C. Subgrade.** The top surface of a roadbed upon which the pavement structure, shoulders, and curbs are constructed.
- D. Subgrade Treatment.** Modifying or stabilizing material in the subgrade.

1.90. Payment Bond. The security executed by the Contractor and the Surety, furnished to the Department to guarantee payment of all legal debts of the Contractor pertaining to the Contract.

1.91. Performance Bond. The security executed by the Contractor and the Surety, furnished to the Department to guarantee the completion of the work in accordance with the terms of the Contract.

1.92. Plans. The drawings approved by the Engineer including true reproductions of the drawings that show the location, character, dimensions, and details of the work and are a part of the Contract.

1.93. Power of Attorney for Surety Bonds. An instrument under corporate seal appointing an attorney-in-fact to act on behalf of a Surety in signing bonds.

1.94. Prequalification. The process for determining a Contractor's eligibility to bid work.

1.95. Prequalification Statement. The forms on which required information is furnished concerning the Contractor's ability to perform and finance the work.

1.96. Project-Specific Location (PSL). A material source, plant, waste site, parking area, storage area, field office, staging area, haul road, or other similar location either outside the project limits or within the project limits

1.96 to 1.104

but not specifically addressed in the PS&E. PSLs defined here are the work areas that exist only for the specific Contract.

1.97. Proposal. The offer of the Bidder submitted on the prescribed form, including addenda issued, giving unit bid prices for performing the work described in the plans and specifications.

1.98. Proposal Form. The document issued by the Department for a proposed Contract that includes:

- the specific locations (except for non-site-specific work) and description of the proposed work;
- an estimate of the various quantities and kinds of work to be performed or materials to be furnished;
- a schedule of items for which unit prices are requested;
- the number of working days within which the work is to be completed (or reference to the requirements); and
- the special provisions and special specifications applicable to the proposed Contract.

1.99. Proposal Guaranty. The security designated in the proposal and furnished by the Bidder as a guarantee that the Bidder will enter into a Contract if awarded the work.

1.100. Quality Assurance (QA). Sampling, testing, inspection, and other activities conducted by the Engineer to determine payment and make acceptance decisions.

1.101. Quality Control (QC). Sampling, testing, and other process control activities conducted by the Contractor to monitor production and placement operations.

1.102. Ramp. A section of highway for the primary purpose of making connections with other highways.

1.103. Recurring Maintenance Work Contracts. Contracts or work for which maintenance is needed at the same location on more than one occasion (e.g., mowing contracts for which mowing cycles are requested on multiple occasions).

1.104. Referee Tests. Tests requested to resolve differences between Contractor and Engineer test results. The referee laboratory is the Construction Division, Materials and Pavements Section.

1.105. Regular Item. A bid item contained in a proposal and not designated as an alternate bid item.

1.106. Rental Rate Blue Book for Construction Equipment. Publication containing equipment rental rates.

1.107. Responsive Bid. A proposal that meets all requirements of the proposal form for acceptance.

1.108. Right of Way. A general term denoting land or property devoted to transportation purposes.

1.109. Roadbed. The graded portion of a highway prepared as foundation for the pavement structure and shoulders. On divided highways, the depressed median type and the raised median type highways are considered to have 2 roadbeds. Highways with a flush median are considered to have 1 roadbed.

1.110. Road Master. A railroad maintenance official in charge of a division of railway.

1.111. Roadside. The areas between the outside edges of the shoulders and the right of way boundaries. Unpaved median areas between inside shoulders of divided highways and areas within interchanges are included.

1.112. Roadway. The portion of the highway (including shoulders) used by the traveling public.

1.113. Routine Maintenance Contract (RMC). A Contract let through the routine maintenance contracting procedure to preserve and repair roadways, rights of way, and appurtenances.

1.114. Sandblasting, Dry. Spraying blasts of pressurized air combined with sand.

1.115. Sandblasting, Wet. Spraying blasts of pressurized water combined with sand.

1.116. Shoulder. That portion of the roadway contiguous with the traffic lanes for accommodation of stopped vehicles for emergency use or for lateral support of base and surface courses.

1.117. Shot Blasting. Spraying blasts of pressurized air combined with metal shot.

1.118 to 1.128

1.118. Sidewalk. Portion of the right of way constructed exclusively for pedestrian use.

1.119. Slurry Blasting. Spraying blasts of pressurized air combined with a mixture of water and abrasive media.

1.120. Special Provisions. Additions or revisions to these standard specifications or special specifications.

1.121. Special Specifications. Supplemental specifications applicable to the Contract not covered by these standard specifications.

1.122. Specifications. Directives or requirements issued or made pertaining to the method and manner of performing the work or to quantities and qualities of materials to be furnished under the Contract. References to DMSs, ASTM or AASHTO specifications, or Department bulletins and manuals, imply the latest standard or tentative standard in effect on the date of the proposal. The Engineer will consider incorporation of subsequent changes to these documents in accordance with Item 4, "Scope of Work."

1.123. Small Business Enterprise (SBE). A firm (including affiliates) whose annual gross receipts do not exceed the U.S. Small Business Administration's size standards for 4 consecutive years.

1.124. State. The State of Texas.

1.125. State Holiday. A holiday authorized by the State Legislature excluding optional state holidays and not listed in Article 1.82, "National Holidays." Contact the Construction Division for a list.

1.126. Station. A unit of measurement consisting of 100 horizontal feet.

1.127. Subcontract. The agreement between the Contractor and subcontractor establishing the obligations of the parties for furnishing of materials and performance of the work prescribed in the Contract documents.

1.128. Subcontractor. An individual, partnership, limited liability company, corporation, or any combination thereof that the Contractor sublets, or proposes to sublet, any portion of a Contract, excluding a material supplier, truck owner-operator, wholly owned subsidiary, or specialty-type businesses such as security companies and rental companies.

1.129. Subsidiary. Materials, labor, or other elements that because of their nature or quantity have not been identified as a separate item and are included within the items on which they necessarily depend.

1.130. Substructure. The part of the structure below the bridge seats or below the springing lines of arches. Parapets, back walls, and wing walls of abutments are considered as parts of the substructure.

1.131. Superintendent. The representative of the Contractor who is available at all times and able to receive instructions from the Engineer or authorized Department representatives and to act for the Contractor.

1.132. Superstructure. The part of the structure above the bridge seats or above the springing lines of arches.

1.133. Supplemental Agreement. Written agreement entered into between the Contractor and the State and approved by the Surety, covering alterations and changes in the Contract. A supplemental agreement is used by the Department whenever the modifications include assignment of the Contract from 1 entity to another or other cases as desired by the Department.

1.134. Surety. The corporate body or bodies authorized to do business in Texas bound with and for the Contractor for the faithful performance of the work covered by the Contract and for the payment for all labor and material supplied in the prosecution of the work.

1.135. Surplus Materials. Any debris or material related to the Contract not incorporated into the work.

1.136. Traffic Lane. The strip of roadway intended to accommodate the forward movement of a single line of vehicles.

1.137. Traveled Way. The portion of the roadway for the movement of vehicles, exclusive of shoulders and auxiliary lanes.

1.138. Truck Owner-Operator. An individual who owns and operates 1 truck for hire.

1.139. Utility. Privately, publicly, or cooperatively owned lines, facilities, and systems for producing, transmitting, or distributing communications, power, heat, gas, oil, water, waste, or storm water that are not connected

1.139 to 2.1

with the highway drainage, signal systems, or other products that directly or indirectly serve the public; the utility company.

1.140. Verification Tests. Tests used to verify accuracy of QC and QA and mixture design testing.

1.141. Water-Abrasive Blasting. Spraying blasts of pressurized water combined with abrasive media.

1.142. Water Blasting. Spraying blasts of pressurized water of at least 3,000 psi.

1.143. Water-Injected Abrasive Blasting. Abrasive blasting with water injected into the abrasive/air stream at the nozzle.

1.144. Wholly Owned Subsidiary. A legal entity owned entirely by the Contractor or subcontractor.

1.145. Work. The furnishing of all labor, materials, equipment, and other incidentals necessary for the successful completion of the Contract.

1.146. Work Order. Written notice to the Contractor to begin the work. The work order may include the date on which work or time charges are to begin, the number of working days for specified work (for multiple work order Contracts), and plan sheets providing additional details specific to a location or to an item of work for non-site-specific work.

1.147. Written Notice. Written notice is considered to have been duly given if delivered in person to the individual or member to whom it is intended or if sent by regular, registered, or certified mail and delivered to the last known business address; sent by facsimile to the last known phone number; or sent by e-mail to the last known address. The date of the letter will serve as the beginning day of notice. Unclaimed mail or failure to provide current mailing address will not be considered a failure to provide written notice.

ITEM 2

INSTRUCTIONS TO BIDDERS

2.1. Introduction. Instructions to the Contractor in these specifications are generally written in active voice, imperative mood. The subject of imperative sentences is understood to be “the Contractor.” The

Department's responsibilities are generally written in passive voice, indicative mood. Phrases such as "as approved," "unless approved," "upon approval," "as directed," "as verified," "as ordered," and "as determined" refer to actions of the Engineer unless otherwise stated, and it is understood that the directions, orders, or instructions to which they relate are within the limitations of and authorized by the Contract.

2.2. Eligibility of Bidders. Submit for approval a Confidential Questionnaire Form and an audited financial statement, or a Bidder's Questionnaire Form, at least 10 days before the date that bids are to be opened. Once approved, the eligibility is valid for a period of one year. Bidders prequalified with a Bidder's Questionnaire Form only are not eligible to bid on a proposal that require the Confidential Questionnaire Form and audited financial statements. Comply with all technical prequalification requirements in the proposal. Obtain prequalification forms from the Construction Division.

2.3. Issuing Proposal Forms. Request proposal forms orally or in writing. The Department will issue a proposal form to a prequalified Bidder meeting the requirements of the proposal form on request if the estimated cost of the proposed Contract is within that Bidder's available bidding capacity.

In the case of a joint venture, all joint venture participants must be prequalified. An equally divided portion of the Engineer's estimate must be within each participant's available bidding capacity.

The Department will not issue a proposal form if one or more of the following apply:

- For a proposed Contract involving federal funds, at the time of the request the Bidder is disqualified by an agency of the federal government as a participant in programs and activities involving federal assistance and benefits.
- For any proposed Contract, at the time of the request, the Bidder is suspended or debarred by the Commission, or is prohibited from rebidding a specific proposal because of bid error or failure to enter into a Contract of the first awarded bid.
- For any proposed Contract, at the time of the request, the Bidder has not fulfilled the requirements for prequalification.
- For any proposed Contract, the Bidder or a subsidiary or affiliate of the Bidder has received compensation from the Department to participate in the preparation of the plans or specifications on which the bid or Contract is based.

2.4 to 2.6

- For any proposed Contract, the Bidder did not attend an advertised mandatory pre-bid conference.

2.4. Interpreting Estimated Quantities. The quantities listed in the proposal form are approximate and will be used for the comparison of bids. Payments will be made for the work performed in accordance with the Contract.

2.5. Examining Documents and Work Locations. Examine the proposal form, plans, specifications, and specified work locations before submitting a bid for the work contemplated. Submitting a bid will be considered evidence that the Bidder has performed this examination.

Borings, soil profiles, water elevations, and underground utilities shown on the plans were obtained for use of the Department in the preparation of plans. This information is provided for the Bidder's information only and the Department makes no representation as to the accuracy of the data. Be aware of the difficulty of accurately classifying all material encountered in making foundation investigations, the possible erosion of stream channels and banks after survey data have been obtained, and the unreliability of water elevations other than for the date recorded.

Oral explanations, instructions, or consideration for contractor-proposed changes in the proposal given during the bidding process are not binding. Only requirements included on the proposal and associated specifications and plans and in subsequent Department-issued addenda are binding.

To allow the Department to reply before the bid opening date, request explanations of documents in adequate time.

Immediately notify the Department of any error, omission, or ambiguity discovered in any part of the bid package. The Department will issue an addendum when appropriate.

2.6. Preparing the Proposal. Submit the proposal on the form furnished by the Department. Make entries in ink. Specify a unit price in dollars and cents for each Item for which an estimated quantity is given. When "Working Days" is an Item, submit the number of working days to be used to complete the Contract, or phases of the Contract shown on the plans. Include unit bid prices for each Item in the Item group or alternate Item group, except for instances when alternate Items pertain to foreign steel or iron materials. An Item left blank will constitute an incomplete bid and will be handled as prescribed in Article 2.14, "Tabulating Bids."

If a proposal contains alternate Items pertaining to foreign steel or iron materials and the Bidder wishes to bid using foreign steel or iron materials, submit unit prices for both the regular Items using domestic steel or iron materials and alternate Items using foreign steel or iron materials. If the Bidder wishes to bid using domestic steel or iron materials, submit unit prices only for the regular domestic Items; unit prices for alternate Items using foreign steel are not necessary.

Execute the proposal in ink. Provide the complete and correct name of the Bidder submitting the proposal. The person authorized to bind the Bidder or Bidders must sign the proposal. In the case of a joint venture, the complete and correct name of all Bidders submitting the proposal must be provided and all persons authorized to bind the Bidders must sign the proposal.

As an alternative to hand writing the unit prices in words in ink in the proposal, submit a computer printout signed by the person authorized to bind the Bidder. In the case of a joint venture, the persons authorized to bind the Bidders must sign the computer printout. As a minimum, computer printouts must contain the information in the format shown on the “Example of Bid Prices Submitted by Computer Printout” form in the proposal.

Verify whether addenda have been issued on a proposed Contract. Acknowledge all addenda. Enter the date or dates of the addendum notification letter or letters on the addenda acknowledgement page in the proposal form.

2.7. Nonresponsive Proposals. A proposal that has one or more of the deficiencies listed below is nonresponsive and will not be considered.

- A. The person or, in the case of a joint venture, persons do not sign the proposal.
- B. The proposal guaranty does not comply with the requirements contained in Article 2.8, “Proposal Guaranty.”
- C. The proposal is in a form other than the official proposal form issued to the Bidder or Bidders.
- D. The proposal was not in the hands of the letting official at the time and location specified in the advertisement.
- E. The proposal submitted has the incorrect number of Items.
- F. A computer printout, when used, is not signed in the name of the Bidder (or joint Bidders, in the case of a joint venture), is not in the proper format, or omits required Items or includes an Item or Items not shown in the proposal.

2.8 to 2.9

- G. The Bidder was not authorized to receive a proposal under Article 2.3, “Issuing Proposal Forms.”
- H. The Bidder submits more than one proposal, under the same or different name, for a specific proposed Contract. (A Bidder may submit a bid proposal and participate as a material supplier, subcontractor, or both to any or all Bidders contemplating submitting a proposal for this work.)
- I. The Bidder fails to acknowledge or improperly acknowledges receipt of all addenda issued.
- J. The Bidder bids more than the maximum or less than the minimum number of allowable working days shown on the plans when working days is an Item.
- K. The Bidder modifies the proposal in a manner that alters the conditions or requirements for work as stated in the proposal form.
- L. The Bidder did not attend a specified mandatory pre-bid conference.

2.8. Proposal Guaranty. Include a proposal guaranty in the amount indicated on the proposal form, in the form of either a guaranty check or a bid bond. The proposal guaranty amount is fixed at the amount indicated on the proposal form on the date the bid proposal is released to the public.

- A. **Guaranty Check.** The proposal guaranty must be payable to the Texas Transportation Commission and must be a cashier’s check, money order, or teller’s check drawn by or on a state or national bank, a savings and loan association, or a state or federally chartered credit union (collectively referred to as “bank”). The type of check or money order must be indicated on the face of the instrument and the instrument must be no more than 90 days old. A check must be made payable at or through the institution issuing the instrument; be drawn by a bank and on a bank; or be payable at or through a bank. The Department will not accept personal checks, certified checks, or other types of money orders as a proposal guaranty.
- B. **Bid Bond.** The bid bond must be on the form provided by the Department, with powers of attorney attached, and in the amount specified on the bid bond form. The bond form must bear the impressed seal of the Surety and be signed by the Bidder and an authorized individual of the Surety. Bid bonds will only be accepted from Sureties authorized to execute a bond under and in accordance with state law.

2.9. Delivery of Proposal. Place the completed proposal form and the proposal guaranty in a sealed envelope marked to indicate the contents.

When submitting by mail, place the envelope in another sealed envelope and address as indicated in the official advertisement. It is the bidder's responsibility to ensure that the sealed proposal arrives at the location described in the official advertisement of the project on or before the hour and date set for the opening. The proposal must be in the hands of the Letting Official by that time, regardless of the method chosen for delivery, in order to be accepted.

2.10. Revising Proposals. Revisions to proposals will be handled as follows:

- A. Before Submission.** In ink, make desired changes and initial the changes.
- B. After Submission.** Withdraw the proposal in accordance with Article 2.11, "Withdrawing Proposals." In ink, make desired changes and initial the changes. Resubmit to the Letting Official in accordance with Article 2.9, "Delivery of Proposal." The Department will not make revisions to a proposal on behalf of a Bidder.
- C. After Bid Opening.** Proposal revisions are not allowed after the time of bid opening.

2.11. Withdrawing Proposals. Submit a signed written request to the Letting Official. The Department will not accept telephone or electronic requests, but will accept a properly signed telefacsimile request. The request must be made by a person authorized to bind the Bidder, and must be in the hands of the Letting Official before the scheduled bid opening.

2.12. Public Opening of Proposal. Bids are opened and read publicly by the Letting Official at the time and location specified in the official advertisement.

2.13. Gratuities. Do not offer Department employees benefits, gifts, or favors. The only exceptions allowed are ordinary business lunches. Failure to honor this policy may result in the termination of the Contract and sanctions under the Texas Administrative Code. Termination of the Contract will be in accordance with Article 8.7, "Termination of Contract."

2.14. Tabulating Bids.

- A. Official Total Bid Amount.** The Department will sum the products of the quantities and the unit prices bid in the proposal to determine the official total bid amount. Except as provided in Section 2.14.G, "Special Item Considerations," the official total bid amount is the basis

2.14 to 2.14

for determining the apparent low Bidder. The total bid amounts will be compared and the results made public.

- B. Consideration of Bid Format.** When a Bidder submits both a completed proposal form and a properly completed computer printout, the Department will use the unit bid prices shown on the computer printout to determine the total bid amount. If the computer printout is incomplete, the Department will use the completed proposal form to determine the total bid amount of the proposal. If a Bidder submits two or more acceptable computer printouts reflecting different totals, the Department will use the lowest tabulation of all printouts.
- C. Rounding of Unit Prices.** The Department will round off all unit bids involving fractional parts of a cent to the nearest one-tenth cent in determining the amount of the bid as well as computing the amount due for payment of each Item under the Contract. For rounding purposes, entries of five-hundredths of a cent or more will be rounded up to the next highest tenth of a cent, while entries less than five-hundredths of a cent will be rounded down to the next lowest tenth of a cent.
- D. Interpretation of Unit Prices.** The Department will make a documented determination of the unit bid price for tabulation purposes if a unit bid price is illegible. The Department's determination will be final.
- E. Consideration of Unit Prices.** Unit bid price entries such as no dollars and no cents, zero dollars and zero cents, or numerical entries of \$0.00, will be tabulated as one-tenth of a cent (\$0.001).

The Department will consider proposals where unit bid prices have been left blank incomplete and nonresponsive. If a proposal has a regular and a corresponding alternate Item or group of Items, the proposal will be considered complete if:

- the regular Item or group of regular Items has unit prices entered, or
- the alternate Item or group of alternate Items has unit prices entered.

The bid will be considered incomplete and nonresponsive if:

- a regular Item or group of regular Items is left blank, and
- a corresponding alternate Item or group of alternate Items is left blank.

- F. Consideration of Alternate Items.** The Department will make two calculations using one-tenth of a cent (\$0.001) for each Item if:

- a regular Item or a group of Items have an entry such as no dollars and no cents, zero dollars and zero cents, or numerical entries of \$0.00, and
- a corresponding alternate Item or group of Items, have an entry such as no dollars and no cents, zero dollars and zero cents, or numerical entries of \$0.00.

The Department will select the regular Item or Items or the alternate Item or Items at the Department's discretion if both the regular and alternate bid results in the same cost to the State.

The Department will use the unit price that is greater than zero for bid tabulation if:

- a unit price greater than zero has been entered for either a regular bid or a corresponding alternate Item or group of Items, and
- an entry of no dollars and no cents, zero dollars and zero cents, or a numerical entry of \$0.00 has been entered for the other corresponding Item or group of Items.

If a unit price has been entered for both the regular Item and a corresponding alternate Item, the Department will select the option (regular or alternate) that results in the lowest cost to the State. The Department will select the regular Item or Items or the alternate Item or Items at the Department's discretion if both the regular and alternate bid results in the same cost to the State.

G. Special Item Considerations.

1. **Rubber Additives.** For proposed Contracts without federal funds, if an alternate Item for "Hot Asphalt-Rubber Surface Treatments" or "Hot Mix Asphalt Concrete Pavement" which contains ground tire rubber is shown in the proposal and the Bidder bids that alternate Item, the amounts bid for "Hot Asphalt-Rubber" and "Aggregate" or "Hot Mix Asphalt Concrete" will be reduced to 85% of the amounts actually bid. This reduction will only be used for the purposes of determining the lowest Bidder. To qualify, the ground tire rubber used must be produced from scrap tire ground in a facility in Texas. Payment for "Hot Asphalt-Rubber" and "Aggregate" or "Hot Mix Asphalt Concrete" will be at the actual unit prices bid.
2. **"Buy America."** For proposed Contracts where unit bid prices are submitted for both domestic and foreign steel or iron materials, the total bid amount will be calculated using both the domestic and foreign steel unit bid prices. If the total bid amount using the foreign steel or iron materials is the low bid, and the lowest bid

2.15 to 2.16

using domestic steel or iron materials exceeds the low bid using foreign steel or iron materials by 25% or more, the apparent low Bidder will be the bid using foreign steel or iron materials. If the difference between the low bid using foreign steel or iron materials and the lowest bid using domestic steel or iron materials is less than 25%, the apparent low Bidder will be the bid using domestic steel or iron materials.

- 3. Home State Bidding Preference.** For the purpose of determining the apparent low Bidder on proposed Contracts without federal funds, the total bid amount will be based upon the reverse application of the non-resident Bidder's home state bidding preference, if any.

2.15. Consideration of Bid Errors. The Department will consider a claim of a bid error by the apparent low Bidder if the following requirements have been met:

- Submit written notification to the Department within 5 business days after the date the proposal is opened.
- Identify the Items of work involved and include bidding documentation. The Department may request clarification of submitted documentation.

The Department will evaluate the claim of an error by the apparent low Bidder by considering the following:

- The bid error relates to a material Item of work.
- The bid error amount is a significant portion of the total bid.
- The bid error occurred despite the exercise of ordinary care.
- The delay of the proposed work will not impact cost and safety to the public.

Acceptance of the bid error claim by the Department will result in the rejection of all bids. The erring Contractor will not be allowed to bid the project when it is relet. Rejection of bids due to the Contractor's bid error may result in the application of sanctions by the Department.

2.16. Tie Bids. If the official total bid amount for two or more Bidders is equal and those bids are the lowest submitted, each tie Bidder will be given an opportunity to withdraw their bid. If two or more tie Bidders do not withdraw their bids, the low Bidder will be determined by a coin toss. If all tie Bidders request to withdraw their bids, no withdrawals will be allowed and the low Bidder will be determined by a coin toss.

ITEM 3**AWARD AND EXECUTION OF CONTRACT**

3.1. Award of Contract. The Commission or designated representative will award, reject, or defer the Contract within 30 days after the opening of the proposal. The Department reserves the right to reject any or all proposals and to waive technicalities in the best interest of the State.

A. Award. The Commission or designated representative will award the Contract to the low Bidder as determined by Article 2.14, "Tabulation of Bids." The Commission may award a Contract to the second lowest Bidder when the following requirements have been met:

1. The Contract is for routine maintenance work with a bid less than \$100,000.
2. The low Bidder withdraws its bid.
3. The low Bidder's unit bid prices are reasonable.
4. The Executive Director recommends in writing the award of the Contract to the second lowest Bidder.
5. The second lowest Bidder agrees to perform the work at the unit bid prices of the low Bidder.
6. The Commission agrees with the Executive Director's recommendation for award to the second lowest Bidder.

B. Rejection. The Commission or designated representative will reject the Contract if:

1. Collusion may have existed among the Bidders. Collusion participants will not be allowed to bid future proposals for the same Contract.
2. The low bid is mathematically and materially unbalanced. The Bidder will not be allowed to bid future proposals for the same Contract.
3. The lowest bid is higher than the Department's estimate and re-advertising for bids may result in a lower bid.
4. The low bid contains a bid error that satisfies the requirements and criteria in Article 2.15, "Consideration of Bid Errors."
5. Rejection of the Contract is in the best interest of the State.

C. Deferral. The Commission may defer the award or rejection of the Contract when deferral is in the best interest of the State.

3.2 to 3.5

3.2. Rescinding of Award. The Commission or designated representative reserves the right to cancel the award of any Contract before contract execution with no compensation due when the cancellation is in the best interest of the State. The Department will return the proposal guaranty to the Contractor.

3.3. Disadvantaged Business Enterprise (DBE)/Small Business Enterprise (SBE). Submit all DBE/SBE information in the timeframe specified when required by the proposal.

3.4. Execution of Contract. Provide the following within 15 days after written notification of award of the Contract:

- A. Contracts.** Executed by Contractor and Surety.
- B. Bonds.** Executed performance bond and payment bond in the full amount of the Contract price with powers of attorney. Provide bonds in accordance with Table 1. Furnish the payment and performance bonds as a guaranty for the protection of the claimants and the Department for labor and materials and the faithful performance of the work.

**Table 1
Bonding Requirements**

Contract Amount	Required Bonds
Less than \$25,000	None
\$25,000 to \$100,000	Payment
More than \$100,000	Performance and Payment

- C. Certificate of Insurance.** For construction and building Contracts, submit a certificate of insurance showing coverages in accordance with Contract requirements. For routine maintenance Contracts, refer to Article 3.8, "Beginning of Work," for submission requirements.
- D. Business Ownership Information.** Submit the names and social security number of all individuals owning 25% or more of the firm, or firms in the case of a joint venture, on the Department's form.
- E. List of Quoting Suppliers and Subcontractors.** For a construction Contract, submit a list of all suppliers and subcontractors that quoted on the Contract. Include names, addresses, telephone numbers, and types of work required.

3.5. Failure to Enter Contract. If the Contractor fails to comply with all of the requirements in Article 3.4, "Execution of Contract," the proposal guaranty will become the property of the State, not as a penalty, but as

liquidated damages. The Contractor forfeiting the proposal guaranty will not be considered in future proposals for the same work unless there has been a substantial change in design of the work.

3.6. Approval and Execution of Contract. The Contract will be approved and signed under authority of the Commission.

3.7. Return of Proposal Guaranty. The proposal guaranty check of the low Bidder will be retained until after the Contract has been rejected or awarded and executed. Bid bonds will not be returned.

3.8. Beginning of Work. Do not begin work until authorized in writing by the Engineer. For a routine maintenance Contract, do not begin work until work is authorized in writing and a certificate of insurance showing coverages in accordance with the Contract requirements is provided and accepted. Upon execution of the Contract the Department may begin issuing work orders. Work orders may include additional plans describing the work (for non-site-specific work or Contracts) and the allowable number of working days (for recurring maintenance or non-site-specific work or Contracts). The additional plans associated with the work order will become a part of the Contract.

In addition, when callout work is required, provide a method of contact (e-mail, phone, voice message, facsimile, or method shown on the plans) available from 8 A.M. until 5 P.M. every work day and 24 hr. a day, 7 days a week for work with emergency mobilization, unless otherwise shown on the plans. The time of notice will be the transmission time of the notice sent, provided orally, or provided in person by the Department's representative.

Verify all quantities of materials shown on the plans before ordering. For non-site-specific Contracts, purchase of materials before a work order is issued requiring them, without prior written approval of the Engineer, is at the Contractor's risk and the Department is not obligated for cost of unused materials or work to acquire the materials.

3.9. Assignment of Contract. Do not assign, sell, transfer, or otherwise dispose of the Contract or any portion rights, title, or interest (including claims) without the approval of the Commission or designated representative. The Department must deem any proposed assignment justified and legally acceptable before the assignment can take place.

3.10 to 4.2

3.10. Excluded Parties. The Contractor certifies by signing the Contract that the Contractor will not enter into any subcontract with a subcontractor that is debarred or suspended by the Department or any federal agency.

ITEM 4 SCOPE OF WORK

4.1. Contract Intent. The intent of the Contract is to describe the completed work to be performed. Furnish materials, supplies, tools, equipment, labor, and other incidentals necessary for the proper prosecution and completion of the work in accordance with Contract documents.

4.2. Changes in the Work. The Engineer reserves the right to make changes in the work including addition, reduction, or elimination of quantities and alterations needed to complete the Contract. Perform the work as altered. These changes will not invalidate the Contract nor release the Surety.

If the changes in quantities or the alterations do not significantly change the character of the work under the Contract, the altered work will be paid for at the Contract unit price. If the changes in quantities or the alterations significantly change the character of the work, the Contract will be amended by a change order. If no unit prices exist, this will be considered extra work and the Contract will be amended by a change order. Provide cost justification as requested, in an acceptable format. Payment will not be made for anticipated profits on work that is eliminated.

Agree upon the scope of work and the basis of payment for the change order before beginning the work. If there is no agreement, the Engineer may order the work to proceed under Article 9.5, "Force Account," or by making an interim adjustment to the Contract. In the case of an adjustment, the Engineer will consider modifying the compensation after the work is performed.

A significant change in the character of the work occurs when:

- the character of the work for any Item as altered differs materially in kind or nature from that in the Contract or
- a major item of work varies by more than 25% from the original Contract quantity. (The 25% variance is not applicable to non-site-specific Contracts.)

When the quantity of work to be done under any major item of the Contract is more than 125% of the original quantity stated in the Contract, then either

party to the Contract may request an adjustment to the unit price on the portion of the work that is above 125%.

When the quantity of work to be done under any major item of the Contract is less than 75% of the original quantity stated in the Contract, then either party to the Contract may request an adjustment to the unit price. For routine maintenance Contracts only, if an adjusted unit price cannot be agreed upon, the Engineer may determine the unit price by multiplying the Contract unit price by the factor in Table 1.

Table 1
Quantity-Based Price Adjustment Factors

% of Original Quantity	Factor
≥ 50 and < 75	1.05
≥ 25 and < 50	1.15
< 25	1.25

If the changes require additional working days to complete the Contract, Contract working days will be adjusted in accordance with Item 8, "Prosecution and Progress."

4.3. Differing Site Conditions. During the progress of the work, differing subsurface or latent physical conditions may be encountered at the site. The two types of differing site conditions are defined as:

- those that differ materially from those indicated in the Contract and
- unknown physical conditions of an unusual nature differing materially from those ordinarily encountered and generally recognized as inherent in the work provided for in the Contract.

Notify the Engineer in writing when differing site conditions are encountered. The Engineer will notify the Contractor when the Department discovers differing site conditions. Unless directed otherwise, suspend work on the affected items and leave the site undisturbed. The Engineer will investigate the conditions and determine whether differing site conditions exist. If the differing site conditions cause an increase or decrease in the cost or number of working days specified for the performance of the Contract, the Engineer will make adjustments, excluding the loss of anticipated profits, in accordance with the Contract. Additional compensation will be made only if the required written notice has been provided.

4.4. Requests and Claims for Additional Compensation. Notify the Engineer in writing of any intent to request additional compensation once

4.4 to 4.4

there is knowledge of the basis for the request. An assessment of damages is not required to be part of this notice but is desirable. The intent of the written notice requirement is to provide the Engineer an opportunity to evaluate the request and to keep an accurate account of the actual costs that may arise. Minimize impacts and costs.

If written notice is not given, the Contractor waives the right to additional compensation unless the circumstances could have reasonably prevented the Contractor from knowing the cost impact before performing the work.

Notice of the request and the documentation of the costs will not be construed as proof or substantiation of the validity of the request. Submit the request in sufficient detail to enable the Engineer to determine the basis for entitlement, adjustment in the number of working days specified in the Contract, and compensation.

A. Delay Claims. The intent of paying for delay damages is to reimburse the Contractor for actual expenses arising out of a compensable impact. No profit or force account markups, other than labor burden, will be allowed. If the Contractor requests compensation for delay damages and the delay is determined to be compensable, then standby equipment costs and project overhead compensation will be based on the duration of the compensable delay and will be limited as follows:

1. Standby Equipment Costs.

- Standby costs will not be allowed during periods when the equipment would have otherwise been idle.
- No more than 8 hr. of standby will be paid during a 24-hr. day, nor more than 40 hr. per week, nor more than 176 hr. per month.
- Standby will be paid at 50% of the rental rates found in the Rental Rate Blue Book for Construction Equipment and calculated by dividing the monthly rate by 176 and multiplying by the regional adjustment factor and the rate adjustment factor. Operating costs will not be allowed.

2. Project Overhead. Project overhead will be determined from actual costs that the Contractor will be required to document. Project overhead is defined as the administrative and supervisory expenses incurred at the work locations.

3. Home Office Overhead. The Department will not compensate the Contractor for home office overhead.

B. Dispute or Claims Procedure. Work with the Engineer to resolve all issues. If an issue cannot be resolved within a time frame agreed to by the Engineer, elevate the issue to appropriate District staff. If the issue

cannot be resolved within the time frame established by the District, the Contractor may submit a contract claim to be handled in accordance with the Department's contract claim procedure maintained by the Construction Division. It is the Contractor's responsibility to prove or justify all claims and requests in a timely manner.

4.5. Maintenance of Traffic. In accordance with the approved traffic control plan and as specified in the Contract, keep existing roadways open to traffic or construct and maintain detours and temporary structures for safe public travel. Maintain the work in passable condition, including proper drainage, to accommodate traffic. Provide and maintain temporary approaches and crossings of intersecting highways in a safe and passable condition. Construct and maintain necessary access to adjoining property as shown in the plans or as directed. Furnish, install, and maintain traffic control devices in accordance with the Contract. The cost of maintaining traffic will be paid for in accordance with the Contract.

The Engineer will notify the Contractor if, in the opinion of the Engineer, the above requirements are not met. The Department may perform the work necessary for compliance, but this does not change the legal responsibilities set forth in the Contract. The cost to the Department will be deducted from money due or to become due to the Contractor.

4.6. Final Cleanup. Upon completion of the work, remove litter, debris, objectionable material, temporary structures, excess materials, and equipment from the work locations. Clean and restore property damaged by the Contractor's operations during the prosecution of the work. Leave the work locations in a neat and presentable condition. This work will not be paid for directly but will be considered subsidiary to Items of the Contract.

Remove from the right of way cofferdams, construction buildings, material and fabrication plants, temporary structures, excess materials, and debris resulting from construction. Where work is in a stream, remove debris to the ground line of the bed of the stream. Leave stream channels and rights of way in a neat and presentable condition. Clean structures to the flow line or the elevation of the outfall channel, whichever is higher. Dispose of all excess material in accordance with federal, state, and local regulations.

5.1 to 5.2

ITEM 5 CONTROL OF THE WORK

5.1. Authority of Engineer. The Engineer has the authority to observe, test, inspect, approve, and accept the work. The Engineer decides all questions about the quality and acceptability of materials, work performed, work progress, Contract interpretations, and acceptable Contract fulfillment. The Engineer has the authority to enforce and make effective these decisions.

The Engineer acts as a referee in all questions arising under the terms of the Contract. The Engineer's decisions will be final and binding.

5.2. Plans and Working Drawings. When required, provide working drawings to supplement the plans with all necessary details not included on the Contract plans. Prepare and furnish working drawings in a timely manner and obtain approval, if required, before the beginning of the associated work. For all working drawing submittal requirements, the Engineer may allow electronic and other alternative submission procedures. Have a licensed professional engineer sign, seal, and date the working drawings as indicated in Table 1.

Prepare working drawings using United States standard measures and in the English language. The routing of submittals for review and approval will be established at the preconstruction conference. The Contractor is responsible for the accuracy, coordination, and conformity of the various components and details of the working drawings. Department approval of the Contractor's working drawings will not relieve the Contractor of any responsibility under the Contract. The work performed under this Article will not be measured or paid for directly, but will be subsidiary to pertinent Items.

Table 1
Signature and Approval Requirements for Working Drawings

Working Drawings For		Requires Licensed Professional Engineer's Signature, Seal, and Date	Requires Departmental Approval
1. Alternate or optional designs submitted by Contractor		Yes	Yes
2. Supplementary shop and fabrication drawings for structural Items		No unless required on the plans	See applicable Item
3. Contractor-proposed temporary facilities that affect the public safety, not included on the plans		Yes	Yes
4. Form and falsework details	Bridges, retaining walls, and other major structures	Yes unless otherwise shown on the plans	No ¹
	Minor structures	No unless otherwise shown on the plans	No
5. Erection drawings		Yes	No ¹
6. Contractor-proposed major modifications to traffic control plan		Yes	Yes

1. The Engineer may require that the Contractor have a licensed professional engineer certify that the temporary works are constructed according to the sealed drawings.

5.3. Conformity with Plans, Specifications, and Special Provisions.

Furnish materials and perform work in reasonably close conformity with the lines, grades, cross-sections, dimensions, details, gradations, physical and chemical characteristics of materials, and other requirements shown in the Contract (including additional plans for non-site-specific work). Reasonably close conformity limits will be as defined in the respective Items of the Contract or, if not defined, as determined by the Engineer. Obtain approval before deviating from the plans and approved working drawings. Do not perform work beyond the lines and grades shown on the plans or any extra work without the Engineer's authority. Work performed beyond the lines and grades shown on the plans or any extra work performed without authority is considered unauthorized and excluded from pay consideration. The Department will not pay for material rejected due to improper fabrication, excess quantity, or any other reasons within the Contractor's control.

A. Acceptance of Defective or Unauthorized Work. When work fails to meet Contract requirements, but is adequate to serve the design

5.4 to 5.5

purpose, the Engineer will decide the extent to which the work will be accepted and remain in place. The Engineer will document the basis of acceptance by a letter and may adjust the Contract price.

- B. Correction of Defective or Unauthorized Work.** When work fails to meet Contract requirements and is inadequate to serve the design purpose it will be considered defective. Correct, or remove and replace, the work at the Contractor's expense, as directed.

The Department has the authority to correct or to remove and replace defective or unauthorized work. The cost may be deducted from any money due or to become due to the Contractor.

5.4. Coordination of Plans, Specifications, and Special Provisions. The specifications, accompanying plans (including additional plans for non-site-specific work), special provisions, change orders, and supplemental agreements are intended to work together and be interpreted as a whole.

Numerical dimensions govern over scaled dimensions. Special provisions govern over plans (including general notes), which govern over standard specifications and special specifications. Job-specific plan sheets govern over standard plan sheets.

However, in the case of conflict between plans (including general notes) and specifications regarding responsibilities for hazardous materials and traffic control in Items 1 through 9 and Item 502, "Barricades, Signs, and Traffic Handling," special provisions govern over standard specifications and special specifications, which govern over the plans.

Notify the Engineer promptly of any omissions, errors, or discrepancies discovered so that necessary corrections and interpretations can be made. Failure to promptly notify the Engineer will constitute a waiver of all claims for misunderstandings or ambiguities that result from the errors, omissions, or discrepancies discovered.

5.5. Cooperation of Contractor. Cooperate with the Engineer, other Contractors, and utility and railroad companies. All work associated with fulfilling this requirement is subsidiary to the various Items of the Contract and no direct compensation will be made. Provide all information necessary to administer the Contract. Maintain at least one copy of the Contract at the work locations at all times.

Designate in writing a competent, English-speaking Superintendent employed by the Contractor. The Superintendent must be experienced with the work being performed and capable of reading and understanding the Contract. Ensure the Superintendent is available at all times and able to

receive instructions from the Engineer or authorized Department representatives and to act for the Contractor. The Engineer may suspend work if a Superintendent is not available or does not meet the above criteria; however, working day charges will not be suspended.

- A. Cooperating with the Engineer.** Cooperate with the Engineer in every way possible. Respond promptly to instructions from the Engineer.
- B. Cooperating with Utilities.** Use established safety practices when working near utilities. Consult with the appropriate utilities before beginning work. Notify the Engineer immediately of utility conflicts. The Engineer will decide whether to adjust utilities or adjust the work to eliminate or lessen the conflict. Unless otherwise shown on the plans, the Engineer will make necessary arrangements with the utility owner when utility adjustments are required.

Use work procedures that protect utilities or appurtenances that remain in place during construction. Cooperate with utilities to remove and rearrange utilities to avoid service interruption or duplicate work by the utilities. Allow utilities access to the right of way.

Immediately notify the appropriate utility of service interruptions resulting from damage due to construction activities. Cooperate with utilities until service is restored. Maintain access to fire hydrants when necessary.

- C. Cooperation Between Contractors.** Cooperate and coordinate with other Contractors working within the limits or adjacent to the limits.
- D. Cooperation with Railroads.** Plan and prosecute portions of the work involving a railway to avoid interference with or hindrance to the railroad company.

5.6. Construction Surveying. Use Method A unless otherwise specified in the Contract. Upon request, the Engineer will allow the Contractor to copy available earthwork cross-sections, computer printouts or data files, and other information necessary to establish and control work. Maintain the integrity of control points. Preserve all control points, stakes, marks, and right of way markers. Assume cost and responsibility of replacing disturbed control points, stakes, marks, and right of way markers. If the Department repairs disturbed control points, stakes, marks, or right of way markers, the cost of repair may be deducted from money due or to become due to the Contractor. Replace right of way markers under the direction of a RPLS. This work will be subsidiary to pertinent Items.

5.7 to 5.7

The Engineer reserves the right to make measurements and surveys to determine the accuracy of the work and determine pay quantities. The Engineer's measurements and surveys do not relieve the Contractor's responsibility for accuracy of work. Allow the Engineer adequate time to verify the surveying.

- A. Method A.** The Engineer will set control points for establishing lines, slopes, grades, and centerlines and for providing both vertical and horizontal control at maximum intervals of 1,500 ft. Use these control points as reference to perform the work.

Furnish materials, equipment, and qualified workforce necessary for the construction survey work. Place construction points, stakes, and marks at intervals sufficient to control work to established tolerances. Place construction stakes at intervals of no more than 100 ft., or as directed. Place stakes and marks so as not to interfere with normal maintenance operations.

- B. Method B.** The Engineer will set adequate control points, stakes, and marks to establish lines, slopes, grades, and centerlines. Furnish additional work, stakes, materials, and templates necessary for marking and maintaining points and lines.

- C. Method C.** Set adequate control points, stakes, and marks to establish lines, slopes, grades, and centerlines.

5.7. Inspection. Inspectors are authorized representatives of the Engineer. Inspectors are authorized to examine all work performed and materials furnished, including preparation, fabrication, and material manufacture. Inspectors inform the Contractor of failures to meet Contract requirements. Inspectors may reject work or materials and may suspend work until any issues can be referred to and decided by the Engineer. Inspectors cannot alter, add, or waive Contract provisions, issue instructions contrary to the Contract, act as foremen for the Contractor, or interfere with the management of the work. Inspection or lack of inspection will not relieve the Contractor from obligation to provide materials or perform the work in accordance with the Contract.

Provide safe access to all parts of the work and provide information and assistance to the Engineer to allow a complete and detailed inspection. Give the Engineer sufficient notice to inspect the work. Work performed without suitable inspection, as determined by the Engineer, may be ordered removed and replaced at Contractor's expense. Remove or uncover portions of finished work as directed. Once inspected, restore work to Contract requirements. If the uncovered work is acceptable, the costs to uncover,

remove, and replace or make good the parts removed will be paid for in accordance with Article 4.2, “Changes in the Work.” If the work is unacceptable, assume all costs associated with repair or replacement, including the costs to uncover, remove, and replace or make good the parts removed.

When a government entity, utility, railroad company, or other entity accepts or pays a portion of the Contract, that organization’s representatives may inspect the work but cannot direct the Contractor. The right of inspection does not make that entity a party to the Contract and does not interfere with the rights of the parties to the Contract.

5.8. Final Acceptance.

- A. Routine Maintenance Contracts.** The Engineer will perform final acceptance and notify the Contractor of acceptance. The Engineer may use final acceptance procedures shown for construction Contracts.
- B. Construction Contracts.** Final acceptance is made when all work is complete and the Engineer, in writing, accepts all work for the work locations in the Contract. Final acceptance relieves the Contractor from further Contract responsibilities.
 - 1. Work Completed.** Work completed must include work for vegetative establishment and maintenance, test, and performance periods and work to meet the requirements of Article 4.6, “Final Cleanup.”
 - 2. Final Inspection.** After all work is complete, the Engineer in charge of the work will request a final inspection by the Engineer authorized to accept the work.

The final inspection will be made as soon as possible, and not later than 10 calendar days after the request. No working day charges will be made between the date of request and final inspection.

After the final inspection, if the work is satisfactory, the Engineer will notify the Contractor in writing of the final acceptance of the work. If the final inspection finds any work to be unsatisfactory, the Engineer will identify in writing all deficiencies in the work requiring correction. Correct the deficiencies identified. Working day charges will resume if these deficiencies are not corrected within 7 calendar days, unless otherwise authorized by the Engineer. Upon correction, the Engineer will make an inspection to verify that all deficiencies were corrected satisfactorily. The Engineer will provide written notice of the final acceptance.

6.1 to 6.1

3. **Final Measurement.** Final measurements and pay quantity adjustments may be made after final acceptance.
 4. **Removal of Traffic Control Devices.** Remove construction traffic control devices and advance warning signs upon final acceptance.
- C. **Multiple Work Order Contracts.** For contracts with multiple work orders (recurring maintenance work or non-site-specific Contracts), final acceptance may be made upon completion of the work for each work order, in accordance with Sections 5.8.A, “Routine Maintenance Contracts,” and 5.8.B, “Construction Contracts.”

ITEM 6

CONTROL OF MATERIALS

6.1. Source Control. Use only materials that meet Contract requirements. Unless otherwise specified or approved, use new materials for the work. Secure the Engineer’s approval of the proposed source of materials to be used before their delivery. Materials can be approved at a supply source or staging area but may be reinspected in accordance with Article 6.4, “Sampling, Testing, and Inspection.”

- A. **Buy America.** Comply with the latest provisions of Buy America as listed at 23 CFR 635.410. Use steel or iron materials manufactured in the United States except when:
- the cost of materials, including delivery, does not exceed 0.1% of the total Contract cost or \$2,500, whichever is greater;
 - the Contract contains an alternate Item for a foreign source steel or iron product and the Contract is awarded based on the alternate Item; or
 - the materials are temporarily installed.

Provide a notarized original of the FORM D-9-USA-1 with the proper attachments for verification of compliance.

Manufacturing is any process that modifies the chemical content, physical shape or size, or final finish of a product. Manufacturing begins with initial melting and mixing and continues through fabrication (cutting, drilling, welding, bending, etc.) and coating (paint, galvanizing, epoxy, etc.).

- B. **Buy Texas.** For construction or routine maintenance Contracts without federal funds, buy materials produced in Texas when the materials are available at a comparable price and in a comparable period of time.

Provide documentation of purchases or a description of good-faith efforts on request.

6.2. Material Quality. Correct or remove materials that fail to meet Contract requirements or that do not produce satisfactory results. Reimburse the Department for cost incurred if additional sampling and testing is required by a change of source.

Materials not meeting Contract requirements will be rejected, unless the Engineer approves corrective actions. Upon rejection, immediately remove and replace rejected materials.

If the Contractor does not comply with this Article, the Department may remove and replace defective material. The cost of testing, removal, and replacement will be deducted from the estimate.

6.3. Manufacturer Warranties. Transfer to the Department warranties and guarantees required by the Contract or received as part of normal trade practice.

6.4. Sampling, Testing, and Inspection. Incorporate into the work only material that has been inspected, tested, and accepted by the Department. Remove, at the Contractor's expense, materials from the work locations that are used without prior testing and approval or written permission of the Engineer.

The material requirements and standard test methods in effect at the time the proposed Contract is advertised govern. Unless otherwise noted, the Department will perform testing at its expense. In addition to facilities and equipment required by the Contract, furnish facilities and calibrated equipment required for tests to control the manufacture of construction Items. If requested, provide a complete written statement of the origin, composition, and manufacture of materials.

All materials used are subject to inspection or testing at any time during preparation or use. Material which that has been tested and approved at a supply source or staging area may be reinspected or tested before or during incorporation into the work, and rejected if it does not meet Contract requirements. Copies of test results are available upon request. Do not use material that, after approval, becomes unfit for use.

Unless otherwise noted in the Contract, all testing must be performed within the United States and witnessed by the Engineer. If materials or processes require testing outside the contiguous 48 United States, reimburse the Department for inspection expenses.

6.5 to 6.8

6.5. Plant Inspection and Testing. The Engineer may but is not obligated to inspect materials at the acquisition or manufacturing source. Material samples will be obtained and tested for compliance with quality requirements. Materials produced under Department inspection are for Department use only unless released in writing by the Engineer.

If inspection is at the plant, meet the following conditions unless otherwise specified:

- Cooperate fully and assist the Engineer during the inspection.
- Ensure the Engineer has full access to all parts of the plant used to manufacture or produce materials.
- In accordance with pertinent Items and the Contract, provide a facility at the plant for use by the Engineer as an office or laboratory.
- Provide and maintain adequate safety measures and restroom facilities.
- Furnish and calibrate scales, measuring devices, and other necessary equipment.

The Engineer may provide inspection for periods other than daylight hours if:

- continuous production of materials for Department use is necessary due to the production volume being handled at the plant and
- the lighting is adequate to allow satisfactory inspection.

6.6. Storage of Materials. Store and handle materials to preserve their quality and fitness for the work. Store materials so that they can be easily inspected and retested. Place materials under cover, on wooden platforms, or on other hard, clean surfaces as necessary or when directed.

Obtain approval to store materials on the right of way. Storage space off the right of way is at the Contractor's expense.

6.7. Department-furnished Material. The Department will supply materials as shown on the plans. The cost of handling and placing materials supplied by the Department will not be paid for directly but is subsidiary to the Item in which they are used. Assume responsibility for materials upon receipt.

6.8. Use of Materials Found on the Right of Way. Material found in the excavation areas and meeting the Department's specifications may be used in the work. This material will be paid for at the Contract bid price for excavation and under the Item for which the material is used.

Do not excavate or remove any material from within the right of way that is not within the limits of the excavation without written permission. If excavation is allowed within a right of way project-specific location (PSL),

replace the removed material with suitable material at no cost to the Department as directed.

6.9. Recycled Materials. Hazardous wastes, as defined in 30 TAC 335, proposed for recycling will not be allowed in Department Contracts. Nonhazardous recyclable materials (NRMs) may be used unless disallowed or restricted by the Specification for the Item. Determine if NRMs are regulated under 30 TAC 312, 330, 332, 334, or 335, and comply with all general prohibitions and requirements. Furnish a written certification, sealed by a licensed professional engineer, that the NRMs are used in accordance with DMS-11000, "Evaluating and Using Nonhazardous Recyclable Materials Guidelines."

6.10. Hazardous Materials. Use materials that are free of hazardous materials as defined in Item 1, "Definition of Terms."

Notify the Engineer immediately when a visual observation or odor indicates that materials in required material sources or on sites owned or controlled by the Department may contain hazardous materials. The Department is responsible for testing and removing or disposing of hazardous materials not introduced by the Contractor on sites owned or controlled by the Department. The Contractor is not required to test, remediate, or remove hazardous materials that the Contractor did not introduce onto the work locations. The Engineer may suspend the work wholly or in part during the testing, removal, or disposition of hazardous materials on sites owned or controlled by the Department.

When a visual observation or odor indicates that materials delivered to the work locations by the Contractor may contain hazardous materials, have an approved commercial laboratory test the materials for contamination. Remove, remediate, and dispose of any of these materials found to be contaminated. Testing, removal, and disposition of hazardous materials introduced onto the work locations by the Contractor will be at the Contractor's expense. Working day charges will not be suspended and extensions of working days will not be granted for activities related to handling hazardous material delivered by the Contractor.

6.11. Surplus Materials. Take ownership of surplus materials unless otherwise shown on the plans or directed. Remove and dispose of materials in accordance with federal, state, and local regulations. If requested, provide an appropriate level of documentation to verify proper disposal. When materials are disposed of on private property, provide written authorization

6.11 to 7.4

from the property owner for the use of the property for this purpose, upon request.

ITEM 7

LEGAL RELATIONS AND RESPONSIBILITIES

7.1. Laws to be Observed. Comply with all federal, state, and local laws, ordinances, and regulations that affect the performance of the work. The Contractor is not required to comply with city electrical ordinances not included in this Contract. Indemnify and save harmless the State and its representatives against any claim arising from violation by the Contractor of any law, ordinance, or regulation.

This Contract is between the Department and the Contractor only. No person or entity may claim third-party beneficiary status under this Contract or any of its provisions, nor may any non-party sue for personal injuries or property damage under this Contract.

7.2. Permits, Licenses, and Taxes. Procure all permits and licenses; pay all charges, fees, and taxes; and give all notices necessary and incidental to the due and lawful prosecution of work, except for permits provided by the Department and as specified in Article 7.19, "Preservation of Cultural and Natural Resources and the Environment."

7.3. Patented Devices, Material, and Processes. Indemnify and save harmless the State from any claims for infringement from the Contractor's use of any patented design, device, material, process, trademark, or copyright selected by the Contractor and used in connection with the work. Indemnify and save harmless the State against any costs, expenses, or damages that it may be obliged to pay, by reason of this infringement, at any time during the prosecution or after the completion of the work.

7.4. Insurance and Bonds. As specified in Article 3.4, "Execution of Contract," provide the Department with the Department's Certificate of Insurance verifying the types and amounts of coverage shown in Table 1.

Table 1
Insurance Requirements

Type of Insurance	Amount of Coverage
Commercial General Liability Insurance	\$600,000 combined single limit
Business Automobile Policy: Bodily Injury	\$250,000 each person \$500,000 each occurrence
Property Damage	\$100,000 each occurrence
Workers' Compensation	Statutory

By signing the Contract, the Contractor certifies compliance with all applicable laws, rules, and regulations pertaining to workers' compensation insurance or legitimate alternates. This certification includes all subcontractors. Pay all deductibles stated in the policy. Subcontractors must meet the requirements of Table 1 either through their own coverage or through the Contractor's coverage.

The coverage listed in Table 1 must remain in force until final acceptance. If the insurance lapses for any reason, stop all work until the Department receives an acceptable certificate of insurance.

Commercial general liability and business automobile policies must include an endorsement naming the State as an additional named insured. Policies issued for coverage listed in Table 1 must include a waiver of subrogation endorsement in favor of the State.

Provide a substitute Surety on the Contract bonds in the original full Contract amount within 15 days of notification if the Surety is declared bankrupt or insolvent, the Surety's underwriting limitation drops below the Contract amount or the Surety's right to do business is terminated by the State. The substitute Surety must be authorized by the laws of the State and acceptable to the Department. Work will be suspended until a substitute Surety is provided. Working day charges will be suspended for 15 days or until an acceptable Surety is provided, whichever is sooner.

7.5. Restoring Surfaces Opened by Permission. Do not authorize anyone to make an opening in the highway for utilities, drainage, or any other reason without written permission from the Engineer. Repair all openings as directed. Payment for repair of surfaces opened by permission will be made in accordance with pertinent Items or Article 4.2, "Changes in the Work." Costs associated with openings made with Contractor authorization but without Department approval will not be paid.

7.6 to 7.8

7.6. Sanitary Provisions. Provide and maintain adequate, neat, and sanitary toilet accommodations for employees, including State employees, in compliance with the requirements and regulations of the Texas Department of Health or other authorities having jurisdiction.

7.7. Public Safety and Convenience. Manage construction to minimize disruption to traffic. Make every effort to ensure the safety and convenience of the public and property as provided in the Contract and as directed. Follow the safety provisions of all applicable rules, codes, and regulations. Keep all portions of the highway open to traffic, unless otherwise shown on the plans. Maintain the roadway in a good and passable condition. Provide for ingress and egress to adjacent property in accordance with the Contract and as directed. Provide suitable drainage of the roadway and erect temporary structures as required.

If at any time during construction, the approved plan of operation does not accomplish the intended purpose due to any condition affecting the safe handling of traffic, immediately make necessary changes, as directed, to correct the unsatisfactory conditions.

Store all equipment not in use in a manner and at locations that will not interfere with the safe passage of traffic.

Provide qualified flaggers in accordance with Section 502.2.B, “Flaggers,” for the safety and convenience of the traveling public and workers, as directed.

If the Engineer determines that any of the requirements of this Article have not been met, the Engineer may take any necessary corrective action. However, this will not change the legal responsibilities set forth in the Contract. The cost for this work will be deducted from any money due or to become due to the Contractor.

7.8. Hauling and Loads on Roadways and Structures. Comply with federal and state laws concerning legal gross and axle weights. Except for the designated Interstate system, vehicles with a valid yearly overweight tolerance permit may haul materials to the work locations at the permitted load. Provide copies of the yearly overweight tolerance permits to the Engineer upon request. Construction equipment is not exempt from oversize or overweight permitting requirements on roadways open to the traveling public.

Protect existing bridges and other structures that will remain in use by the traveling public during and after the completion of the Contract. Construction traffic on roadways, bridges, and culverts within the limits of

the work, including any structures under construction that will remain in service during and after completion of the Contract is subject to legal size and weight limitations.

Additional temporary fill may be required by the Engineer for hauling purposes for the protection of certain structures. This additional fill will not be paid directly but will be subsidiary.

Replace or restore to original condition any structure damaged by the Contractor's operations.

The Engineer may allow equipment with oversize or non-divisible overweight loads to operate without a permit within the work locations on pavement structures not open to the traveling public. Submit Contractor-proposed changes to traffic control plans for approval, in accordance with Item 502, "Barricades, Signs, and Traffic Handling." The following sections further address overweight allowances. The Department will make available to the Contractor any available plans and material reports for existing structures.

A. Overweight Construction Traffic Crossing Structures. The Engineer may allow crossing of a structure not open to the public within the work locations, when divisible or non-divisible loads exceed legal weight limitations, including limits for load-posted bridges. Obtain written permission to make these crossings. Submit for approval a structural analysis by a licensed professional engineer indicating that the excessive loads should be allowed. Provide a manufacturer's certificate of equipment weight that includes the weight distribution on the various axles and any additional parts such as counterweights, the configuration of the axles, or other information necessary for the analysis. Submit the structural analysis and supporting documentation sufficiently in advance of the move to allow for review by the Engineer. Permission may be granted if the Engineer finds that no damage or overstresses in excess of those normally allowed for occasional overweight loads will result to structures that will remain in use after Contract completion. Provide temporary matting or other protective measures as directed.

Schedule loads so that only one vehicle is on any span or continuous unit at any time. Use barricades, fences, or other positive methods to prevent other vehicular access to structures at any time the overweight load is on any span or continuous unit.

B. Construction Equipment Operating on Structures. Cranes and other construction equipment used to perform construction operations that exceed legal weight limits may be allowed on structures. Before any

7.9 to 7.9

operation that may require placement of equipment on a structure, submit for approval a detailed structural analysis prepared by a licensed professional engineer.

Submit the structural analysis and supporting documentation sufficiently in advance of the use to allow for review by the Engineer. Include all axle loads and configurations, spacing of tracks or wheels, tire loads, outrigger placements, center of gravity, equipment weight, and predicted loads on tires and outriggers for all planned movements, swings, or boom reaches. The analysis must demonstrate that no overstresses will occur in excess of those normally allowed for occasional overweight loads.

- C. Hauling Divisible Overweight Loads on Pavement Within the Work Locations.** The Engineer may allow divisible overweight loads on pavement structures within the work locations not open to the traveling public. Obtain written approval before hauling the overweight loads. Include calculations to demonstrate that there will be no damage or overstress to the pavement structure.

7.9. Barricades, Warning and Detour Signs, and Traffic Handling.

Provide, install, move, replace, maintain, clean, and remove all traffic control devices as shown on the plans and as directed. If details are not shown on the plans, provide devices and work in accordance with the TMUTCD and as directed. When authorized or directed, provide additional signs or traffic control devices not required by the plans.

If an unexpected situation arises that causes the Contractor to believe that the traffic control should be changed, make all reasonable efforts to promptly contact the Engineer. Take prudent actions until the Engineer can be contacted.

If the Engineer determines that any of the requirements of this Article have not been met, the Engineer may take any necessary corrective action. However, this will not change the legal responsibilities set forth in the Contract. The cost for this work will be deducted from any money due or to become due to the Contractor.

The Engineer may authorize or direct in writing the removal or relocation of project limit advance warning signs. When project limit advance warning signs are removed before final acceptance, traffic control in accordance with the TMUTCD may be used for minor operations as approved. Removal or relocation of project limit advance warning signs does not imply final acceptance.

7.10. Using Explosives. Do not endanger life or property. When required by the plans or requested, provide a written blasting plan. The Department retains the right to reject the blasting plan. Store all explosives securely and clearly mark all storage places with “DANGER – EXPLOSIVES.” Store, handle, and use explosives and highly flammable material in compliance with federal, state, and local laws, ordinances, and regulations. Assume liability for property damage, injury, or death resulting from the use of explosives.

Give at least a 48-hr. advance notice to the appropriate Roadmaster before doing any blasting work involving the use of electric blasting caps within 200 ft. of any railroad track.

7.11. Protecting Adjacent Property. Protect adjacent property from damage. If any damage results from an act or omission on the part of or on behalf of the Contractor, take corrective action to restore the damaged property to a condition similar or equal to that existing before the damage was done.

7.12. Responsibility for Damage Claims. Indemnify and save harmless the State and its agents and employees from all suits, actions, or claims and from all liability and damages for any injury or damage to any person or property due to the Contractor’s negligence in the performance of the work and from any claims arising or amounts recovered under any laws, including workers’ compensation and the Texas Tort Claims Act. Indemnify and save harmless the State and assume responsibility for all damages and injury to property of any character occurring during the prosecution of the work resulting from any act, omission, neglect, or misconduct on the Contractor’s part in the manner or method of executing the work; from failure to properly execute the work; or from defective work or material.

Pipelines and other underground installations that may or may not be shown on the plans may be located within the right of way. Indemnify and save harmless the State from any suits or claims resulting from damage by the Contractor’s operations to any pipeline or underground installation. At the pre-construction conference, submit the scheduled sequence of work to the respective utility owners so that they may coordinate and schedule adjustments of their utilities that conflict with the proposed work.

If the Contractor asserts any claim or brings any type of legal action (including an original action, third-party action, or cross-claim) against any Commissioner or individual employee of the Department for any cause of action or claim for alleged negligence arising from the Contract, the

7.13 to 7.14

Contractor will be ineligible to bid on any proposed Contract with the Department during the pendency of the claim or legal action.

7.13. Responsibility for Hazardous Materials. Indemnify and save harmless the State and its agents and employees from all suits, actions, or claims and from all liability and damages for any injury or damage to any person or property arising from the generation or disposition of hazardous materials introduced by the Contractor on any work done by the Contractor on State owned or controlled sites. Indemnify and save harmless the State and its representatives from any liability or responsibility arising out of the Contractor's generation or disposition of any hazardous materials obtained, processed, stored, shipped, etc., on sites not owned or controlled by the State. Reimburse the State for all payments, fees, or restitution the State is required to make as a result of the Contractor's actions.

7.14. Contractor's Responsibility for Work. Until final acceptance of the Contract, take every precaution against injury or damage to any part of the work by the action of the elements or by any other cause, whether arising from the execution or from the nonexecution of the work. Protect all materials to be used in the work at all times, including periods of suspension.

When any roadway or portion of the roadway is in suitable condition for travel, it may be opened to traffic as directed. Opening of the roadway to traffic does not constitute final acceptance.

Repair damage to all work until final acceptance. Repair damage to existing facilities in accordance with the Contract or as directed by the Engineer. Repair damage to existing facilities or work caused by Contractor operations at the Contractor's expense. Repair work for damage that was not due to the Contractor's operations will not be paid for except as provided below.

- A. Reimbursable Repair.** Except for damage to appurtenances listed in Section 7.14.B.1, "Unreimbursed Repair," the Contractor will be reimbursed for repair of damage caused by:
- motor-vehicle, watercraft, aircraft, or railroad-train incident;
 - vandalism; or
 - Acts of God, such as earthquake, tidal wave, tornado, hurricane, or other cataclysmic phenomena of nature.

B. Appurtenances.

1. Unreimbursed Repair. Reimbursement will not be made for repair of damage to the following temporary appurtenances, regardless of cause:

- signs,
- barricades,
- changeable message signs, and
- other work zone traffic control devices.

Crash cushion attenuators and guardrail end treatments are the exception to the above listing and are to be reimbursed in accordance with Section 7.14.B.2, “Reimbursed Repair.”

2. Reimbursed Repair. Reimbursement will be made for repair of damage due to the causes listed in Section 7.14.A, “Reimbursable Repair,” to appurtenances (including temporary and permanent crash cushion attenuators and guardrail end treatments) not listed in Section 7.14.B.1, “Unreimbursed Repair.”

C. Roadways and Structures. Until final acceptance, the Contractor is responsible for all work constructed under the Contract. The Department will not reimburse the Contractor for repair work to new construction, unless the failure or damage is due to one of the causes listed in Section 7.14.A, “Reimbursable Repair.”

The Department will be responsible for the cost for repair of damage to existing roadways and structures not caused by the Contractor’s operations.

D. Detours. The Contractor will be responsible for the cost of maintenance of detours constructed under the Contract, unless the failure or damage is due to one of the causes listed in Section 7.14.A, “Reimbursable Repair.” The Engineer may consider failures beyond the Contractor’s control when determining reimbursement for repairs to detours constructed. The Department will be responsible for the cost of maintenance of existing streets and roadways used for detours or handling traffic.

E. Relief from Maintenance. The Engineer may relieve the Contractor from responsibility of maintenance as outlined in this Section. This relief does not release the Contractor from responsibility for defective materials or work or constitute final acceptance.

1. Isolated Work Locations. For isolated work locations, when all work is completed, including work for Article 4.6, “Final

7.15 to 7.15

Cleanup,” the Engineer may relieve the Contractor from responsibility for maintenance.

2. **Work Except for Vegetative Establishment and Test Periods.**

When all work for all or isolated work locations has been completed, including work for Article 4.6, “Final Cleanup,” with the exception of vegetative establishment and maintenance periods and test and performance periods, the Engineer may relieve the Contractor from responsibility for maintenance of completed portions of work.

3. **Work Suspension.** When all work is suspended for an extended period of time, the Engineer may relieve the Contractor from responsibility for maintenance of completed portions of work during the period of suspension.

F. **Basis of Payment.** When reimbursement for repair work is allowed and performed, payment will be made in accordance with pertinent Items or Article 4.2, “Changes in the Work.”

7.15. Electrical Requirements.

A. Definitions.

1. **Electrical Work.** Electrical work is:

- a. work performed under:
 - Item 610, “Roadway Illumination Assemblies,”
 - Item 614, “High Mast Illumination Assemblies,”
 - Item 616, “Performance Testing of Lighting Systems,”
 - Item 617, “Temporary Roadway Illumination,”
 - Item 618, “Conduit,”
 - Item 620, “Electrical Conductors,”
 - Item 621, “Tray Cable,”
 - Item 622, “Duct Cable,”
 - Item 628, “Electrical Services,”
 - Item 652, “Highway Sign Lighting Fixtures,”
 - Item 680, “Installation of Highway Traffic Signals,” or
 - Item 684, “Traffic Signal Cables”;
- b. work performed under other Items that involves either the distribution of electrical power greater than 50 volts or the installation of conduit and duct banks;
- c. the installation of conduit and wiring associated with Item 624, “Ground Boxes,” and Item 656, “Foundations for Traffic Control Devices”; and

- d. the installation of the conduit system for communication and fiber optic cable.

Electrical work does not include the installation of the communications or fiber optic cable, or the connections for low voltage and inherently power limited circuits such as electronic or communications equipment. Assembly and placement of poles, structures, cabinets, enclosures, manholes, or other hardware will not be considered electrical work as long as no wiring, wiring connections, or conduit work is done at the time of assembly and placement.

2. **Specialized Electrical Work.** Specialized electrical work is work that includes the electrical service and feeders, sub-feeders, branch circuits, controls, raceways, and enclosures for the following:
- pump stations,
 - moveable bridges,
 - ferry slips,
 - motor control centers,
 - facilities required under Item 504, “Field Office and Laboratory,”
 - rest area or other public buildings,
 - weigh-in-motion stations,
 - electrical services larger than 200 amps,
 - electrical services with main or branch circuit breaker sizes not shown in the Contract, and
 - any 3-phase electrical power.
3. **Certified Person.** A certified person is a person who has passed the test from the Texas Engineering Extension Service (TEEX) “TxDOT Electrical Systems” course. Submit a current and valid TEEX certification upon request.
4. **Licensed Electrician.** A licensed electrician is a person with a current and valid unrestricted master electrical license, or unrestricted journeyman electrical license that is supervised or directed by an unrestricted master electrician. An unrestricted master electrician need not be on the work locations at all times electrical work is being done, but the unrestricted master electrician must approve work performed by the unrestricted journeyman. Licensed electrician requirements by city ordinances do not apply to on state system work.

The unrestricted journeyman and unrestricted master electrical licenses must be issued by a city in Texas with population of

7.15 to 7.15

50,000 or greater that issues licenses based on passing a written test and demonstrating experience.

The Engineer may accept other states' electrical licenses. Submit documentation of the requirements for obtaining that license. Acceptance of the license will be based on sufficient evidence that the license was issued based on:

- passing the NEC Block Test or the NEC Southern Building Code Test and
- demonstrating sufficient electrical experience commensurate with general standards for an unrestricted master and unrestricted journeyman electrician.

B. Work Requirements. Table 2 sets forth the qualifications required to perform electrical work and specialized electrical work.

Table 2
Work Requirements

Type of Work	Qualifications to Perform Work
Electrical work with plans	Licensed electrician, certified person, or workers directly supervised by a licensed electrician or certified person
Electrical work without plans	Licensed electrician or workers directly supervised by a licensed electrician
Specialized electrical work	Licensed electrician or workers directly supervised by a licensed electrician
Replace lamps, starting aids, and changing fixtures	Licensed electrician, certified person, or workers directly supervised by a licensed electrician or certified person
Conduit in precast section with approved working drawings	Inspection by licensed electrician or certified person
Conduit in cast-in-place section	Inspection by licensed electrician or certified person
All other electrical work (troubleshooting, repairs, component replacement, etc.)	Licensed electrician or workers directly supervised by a licensed electrician

“Directly supervised by a licensed electrician” means that a licensed electrician is present during all electrical work. “Directly supervised by a licensed electrician or certified person” means that a licensed electrician or certified person is present during all electrical work.

A non-certified person may install conduit in cast-in-place concrete sections if the work is checked by a certified person before concrete placement.

If the plans specify IMSA certification or the completion of other electrical installation courses for traffic signal installation and maintenance, a licensed electrician or certified person will be required only for the installation of conduit, ground boxes, electrical services, pole grounding, and electrical conductors installed under Item 620, “Electrical Conductors.”

7.16. Work Near Railroads.

- A. General.** If the work crosses or is in close proximity to a railroad, do not interfere with the use or operation of the railroad company’s trains or other property. Assign responsible supervisory personnel to ensure that tracks and adjacent areas are clear of debris, road materials, and equipment. It is the Contractor’s responsibility to contact the railroad to determine the railroad’s requirements for work within the railroad right of way and to comply with the requirements. The Department will not reimburse the Contractor for any cost associated with these requirements.

If the work requires construction within 25 ft. horizontally of the near rail or if the tracks may be subject to obstruction due to construction operations, notify the Engineer and Roadmaster at least 3 days before performing work. The railroad company will provide flaggers during this work. If railroad flaggers will be needed longer than 2 consecutive days, request them at least 30 days before performing work within the railroad right of way.

Flaggers provided by the railroad company will be paid for by the Department.

Do not store material or equipment in the Railroad’s right of way within 15 ft. of the centerline of any track. Do not place any forms or temporary falsework within 8.5 ft. horizontally from the centerline or 22 ft. vertically above the top of rails of any track, unless otherwise shown on the plans.

- B. Temporary Crossings.** If a temporary crossing is needed, obtain permission from the railroad company before crossing the tracks. Execute the “Agreement for Contractor’s Temporary Crossing” if required by the Railroad Company. Ensure that the tracks are left clear of equipment and debris that would endanger the safe operation of railroad traffic. Provide a crossing guard on each side of the crossing to

7.17 to 7.19

direct equipment when hauling across the tracks. Stop construction traffic a safe distance away from the crossing upon the approach of railroad traffic.

Work for temporary crossings will not be paid for directly, but is subsidiary to Items of the Contract. Work performed by the railroad company for the temporary crossing, except flaggers, will be at the Contractor's expense.

7.17. Personal Liability of Public Officials. Department employees are agents and representatives of the State and will incur no liability, personal or otherwise, in carrying out the provisions of the Contract or in exercising any power or authority granted under the Contract.

7.18. Abatement and Mitigation of Excessive or Unnecessary Noise. Minimize noise throughout all phases of the Contract. Exercise particular and special efforts to avoid the creation of unnecessary noise impact on adjacent noise sensitive receptors in the placement of non-mobile equipment such as air compressors, generators, pumps, etc. Place mobile and stationary equipment to cause the least disruption of normal adjacent activities.

All equipment associated with the work must be equipped with components to suppress excessive noise and these components must be maintained in their original operating condition considering normal depreciation. Noise-attenuation devices installed by the manufacturer such as mufflers, engine covers, insulation, etc. must not be removed nor rendered ineffectual nor be permitted to remain off the equipment while the equipment is in use.

7.19. Preservation of Cultural and Natural Resources and the Environment. If the Contractor initiates changes to the Contract and the Department approves the changes, the Contractor is responsible for obtaining clearances and coordinating with the appropriate regulatory agencies.

- A. Cultural Resources.** Cease all work immediately if a site, building, or location of historical, archeological, educational, or scientific interest is discovered within the right of way. The site, building, or location will be investigated and evaluated by the Department.
- B. Texas Pollutant Discharge Elimination System (TPDES) Permits and Storm Water Pollution Prevention Plans (SWP3).** The Department will file the Notice of Intent (NOI) and the Notice of Termination (NOT) for work shown on the plans in the right of way. Adhere to all requirements of the SWP3.

- C. Work in Waters of the United States.** For work in the right of way, the Department will obtain any required Section 404 permits from the U.S. Army Corps of Engineers before work begins. Adhere to all agreements, mitigation plans, and standard best management practices required by the permit. When Contractor-initiated changes in the construction method changes the impacts to waters of the U.S., obtain new or revised Section 404 permits.
- D. Work in Navigable Waters of the United States.** For work in the right of way, the Department will obtain any required Section 9 permits from the U.S. Coast Guard before work begins. Adhere to the stipulations of the permits and associated best management practices. When Contractor-initiated changes in the construction method changes the impacts to navigable waters of the U.S., obtain new or revised Section 9 permits.
- E. Work Over the Recharge or Contributing Zone of Protected Aquifers.** Make every reasonable effort to minimize the degradation of water quality resulting from impacts relating to work over the recharge or contributing zones of protected aquifers, as defined and delineated by the TCEQ. Use best management practices and perform work in accordance with Contract requirements.
- F. Project-Specific Locations.** For all project-specific locations (PSLs) on or off the right of way (material sources, waste sites, parking areas, storage areas, field offices, staging areas, haul roads, etc.), signing the Contract certifies compliance with all applicable laws, rules, and regulations pertaining to the preservation of cultural resources, natural resources, and the environment as issued by the following or other agencies:
- Occupational Safety and Health Administration,
 - Texas Commission on Environmental Quality,
 - Texas Department of Transportation,
 - Texas Historical Commission,
 - Texas Parks and Wildlife Department,
 - Texas Railroad Commission,
 - U.S. Army Corps of Engineers,
 - U.S. Department of Energy
 - U.S. Department of Transportation,
 - U.S. Environmental Protection Agency,
 - U.S. Federal Emergency Management Agency, and
 - U.S. Fish and Wildlife Service.

8.1 to 8.2

All subcontractors must also comply with applicable environmental laws, rules, regulations, and requirements in the Contract. Maintain documentation of certification activities including environmental consultant reports, Contractor documentation on certification decisions and contacts, and correspondence with the resource agencies. Provide documentation upon request.

Obtain written approval from the Engineer for all PSLs in the right of way not specifically addressed in the plans. Prepare an SWP3 for all Contractor facilities, such as asphalt or concrete plants located within TxDOT right of way. Comply with all TCEQ permit requirements for portable facilities, such as concrete batch plants, rock crushers, asphalt plants, etc. Address all environmental issues, such as Section 404 permits, wetland delineation, endangered species consultation requirements, or archeological and historic site impacts. Obtain all permits and clearances in advance.

ITEM 8

PROSECUTION AND PROGRESS

8.1. Prosecution of Work. Before starting work, schedule and attend a preconstruction conference with the Engineer. Failure to schedule and attend a preconstruction conference is not grounds for delaying the beginning of working day charges. Unless otherwise shown in the Contract, begin work within 30 calendar days (7 calendar days for routine maintenance Contracts) after the authorization date to begin work as shown on the work order. Prosecute the work continuously to completion within the working days specified. Unless otherwise shown on the plans, work may be prosecuted in concurrent phases if no changes are required in the traffic control plan or if a revised traffic control plan is approved. Notify the Engineer at least 24 hr. before beginning work or before beginning any new operation. Do not start new operations to the detriment of work already begun. Minimize interference to traffic.

When callout work is required, begin work in the right of way within the specified time and continuously prosecute the work until completion.

8.2. Progress Schedules. Schedules are subject to review and acceptance.

A. Routine Maintenance Contracts. Before starting work on a routine maintenance Contract, submit an outline of the proposed procedure for performing the work. Include a sequence of work and an estimated progress schedule if required. Submit revised progress schedules as

requested. When shown on the plans, provide progress schedules meeting the requirements of Section 8.2.B, “Construction Contracts.”

- B. Construction Contracts.** Before starting work on a construction Contract, prepare and submit a progress schedule based on the sequence of work and traffic control plan shown in the Contract. At a minimum, prepare the progress schedule as a bar chart. Include all planned work activities and sequences and show Contract completion within the number of working days specified. Incorporate major material procurements, known utility relocations, and other activities that may affect the completion of the Contract in the progress schedule. Show a beginning date, ending date, and duration in number of working days for each activity. Do not use activities exceeding 20 working days, except for agreed upon activities. Show an estimated production rate per working day for each work activity.

Submit an updated progress schedule monthly, unless otherwise shown in the Contract or as directed. Update the progress schedule by adding actual progress made during the previous update period, including approved changes to the sequence of work and the traffic control plan. If an updated progress schedule indicates the Contract will not be completed within the number of working days specified, notify the Engineer in writing whether the Contractor will revise the progress schedule to meet the number of working days specified or exceed the number of working days specified.

Notify the Engineer in writing of proposed major changes in the progress schedule. Major changes are those that may affect compliance with the Contract requirements or that change the critical path or controlling Item of work. The Engineer reserves the right to reject these proposed changes.

No direct compensation will be made for fulfilling these requirements, as this work is considered subsidiary to the Items of the Contract.

- C. Contracts with Multiple Work Orders.** For multiple work order Contracts, provide a schedule in accordance with Sections 8.2.A, “Routine Maintenance Contracts,” and 8.2.B, Construction Contracts,” for each work order.

8.3. Computation of Contract Time for Completion. Working day charges will begin 15 calendar days (7 calendar days for routine maintenance Contracts) after the date of the written authorization to begin work. Working day charges will continue in accordance with the Contract.

8.3 to 8.3

The Engineer may consider increasing the number of working days under extraordinary circumstances.

- A. Working Day Charges.** Working days will be charged in accordance with Section 8.3.A.4, “Standard Workweek,” unless otherwise shown on the plans. For multiple work order Contracts, working days will be established in each work order on a separate basis. Working days will be computed and charged in accordance with one of the following, as shown in the Contract:
- 1. Five-Day Workweek.** Working days will be charged Monday through Friday, excluding national holidays, regardless of weather conditions or material availability. The Contractor has the option of working on Saturdays. Provide sufficient advance notice to the Engineer when scheduling work on Saturdays. Work on Sundays and national holidays will not be permitted without written permission of the Engineer. If work requiring an Inspector to be present is performed on a Saturday, Sunday, or national holiday, and weather and other conditions permit the performance of work for 7 hr. between 7:00 A.M. and 6:00 P.M., a working day will be charged.
 - 2. Six-Day Workweek.** Working days will be charged Monday through Saturday, excluding national holidays, regardless of weather conditions or material availability. Work on Sundays and national holidays will not be permitted without written permission of the Engineer. If work requiring an Inspector to be present is performed on a Sunday or a national holiday, and weather or other conditions permit the performance of work for 7 hr. between 7:00 A.M. and 6:00 P.M., a working day will be charged.
 - 3. Seven-Day Workweek.** Working days will be charged Monday through Sunday, excluding national holidays, regardless of weather conditions or material availability. Work on national holidays will not be permitted without written permission of the Engineer. If work is performed on any of these holidays requiring an Inspector to be present, and weather or other conditions permit the performance of work for 7 hr. between 7:00 A.M. and 6:00 P.M., a working day will be charged.
 - 4. Standard Workweek.** Working days will be charged Monday through Friday, excluding national or state holidays, if weather or other conditions permit the performance of the principal unit of work underway, as determined by the Engineer, for a continuous period of at least 7 hr. between 7:00 A.M. and 6:00 P.M., unless

otherwise shown in the Contract. The Contractor has the option of working on Saturdays or state holidays. Provide sufficient advance notice to the Engineer when scheduling work on Saturdays. Work on Sundays and national holidays will not be permitted without written permission of the Engineer. If work requiring an Inspector to be present is performed on a Saturday, Sunday, or holiday, and weather or other conditions permit the performance of work for 7 hr. between 7:00 A.M. and 6:00 P.M., a working day will be charged.

5. **Calendar Day.** Working days will be charged Sunday through Saturday, including all holidays, regardless of weather conditions, material availability, or other conditions not under the control of the Contractor.
 6. **Other.** Working days will be charged as shown on the plans.
- B. Restricted Work Hours.** Restrictions on Contractor work hours and the related definition for working day charges are as prescribed in this Article unless otherwise shown on the plans.
- C. Nighttime Work.** Nighttime work is allowed only when shown on the plans or directed or allowed by the Engineer. Nighttime work is defined as work performed from 30 min. after sunset to 30 min. before sunrise.
1. **Five-, Six-, and Seven-Day Workweeks.** Nighttime work that extends past midnight will be assigned to the following day for the purposes of approval for allowing work on Sundays or national holidays.
 2. **Standard Workweek.**
 - a. **Nighttime Work Only.** When nighttime work is allowed or required and daytime work is not allowed, working day charges will be made when weather and other conditions permit the performance of the principal unit of work underway, as determined by the Engineer, for a continuous period of at least 7 hr. for the nighttime period, as defined in Section 8.3.C, unless otherwise shown in the Contract.
 - b. **Nighttime Work and Daytime Work Requiring Inspector.** When nighttime work is performed or required and daytime work is allowed, working day charges will be made when weather and other conditions permit the performance of the principal unit of work underway, as determined by the Engineer, for a continuous period of at least 7 hr. for the nighttime period, as defined in Section 8.3.C, or for a

8.4 to 8.6

continuous period of at least 7 hr. for the alternative daytime period unless otherwise shown in the Contract. Only 1 day will be charged for each 24-hr. time period. When the Engineer agrees to restrict work hours to the nighttime period only, working day charges will be in accordance with Section 8.3.C.2.a.

D. Time Statements. The Engineer will furnish the Contractor a monthly time statement. Review the monthly time statement for correctness. Report protests in writing, no later than 30 calendar days after receipt of the time statement, providing a detailed explanation for each day protested. Not filing a protest within 30 calendar days will indicate acceptance of the working day charges and future consideration of that statement will not be permitted.

8.4. Temporary Suspension of Work or Working Day Charges. The Engineer may suspend the work, wholly or in part, and will provide notice and reasons for the suspension in writing. Suspend and resume work only as directed in writing.

When part of the work is suspended, the Engineer may suspend working day charges only when conditions not under the control of the Contractor prohibit the performance of critical activities. When all of the work is suspended for reasons not under the control of the Contractor, the Engineer will suspend working day charges.

8.5. Failure to Complete Work on Time. The time established for the completion of the work is an essential element of the Contract. If the Contractor fails to complete the work within the number of working days specified, working days will continue to be charged. Failure to complete the Contract, or a separate work order when specified in the Contract, within the number of working days specified, including any approved additional working days, will result in liquidated damages for each working day charged over the number of working days specified in the Contract. The dollar amount specified in the Contract will be deducted from any money due or to become due the Contractor for each working day the Contract or work order remains incomplete. This amount will be assessed not as a penalty, but as liquidated damages. The amount assessed for non-site-specific Contracts will be based on the estimated amount for each work order unless otherwise shown in the Contract.

8.6. Abandonment of Work or Default of Contract. The Engineer may declare the Contractor to be in default of the Contract if the Contractor:

- fails to begin the work within the number of days specified,
- fails to prosecute the work to assure completion within the number of days specified,
- fails to perform the work in accordance with the Contract requirements,
- neglects or refuses to remove and replace rejected materials or unacceptable work,
- discontinues the prosecution of the work without the Engineer's approval,
- makes an unauthorized assignment,
- fails to resume work that has been discontinued within a reasonable number of days after notice to do so,
- is uncooperative, disruptive or threatening, or
- fails to conduct the work in an acceptable manner.

If any of these conditions occur, the Engineer will give notice in writing to the Contractor and the Surety of the intent to declare the Contractor in default. If the Contractor does not proceed as directed within 10 days after the notice, the Department may upon written notice declare the Contractor to be in default of the Contract. The Department will also provide written notice of default to the Surety. Working day charges will continue until completion of the Contract. The Contractor may also be subject to sanctions under the TAC.

The Department will determine the method used for the completion of the remaining work as follows:

- **Contracts without Performance Bonds.** The Department will determine the most expeditious and efficient way to complete the work, and recover damages from the Contractor.
- **Contracts with Performance Bonds.** The Department will, without violating the Contract, demand that the Contractor's Surety complete the remaining work in accordance with the terms of the original Contract. A completing Contractor will be considered a subcontractor of the Surety. The Department reserves the right to approve or reject proposed subcontractors. Work may resume after the Department receives and approves certificates of insurance as required in Article 7.4, "Insurance and Bonds." Certificates of insurance may be issued in the name of the completing Contractor. The Surety is responsible for making every effort to expedite the resumption of work and completion of the Contract. The Department may complete the work using any or all materials at the work locations that it deems suitable and acceptable. Any costs incurred by the Department for the completion of the work under the Contract will be the responsibility of the Surety.

8.7 to 8.7

From the time of notification of the default until work resumes (either by the Surety or the Department), the Department will maintain traffic control devices and will do any other work it deems necessary, unless otherwise agreed upon by the Department and the Surety. All costs associated with this work will be deducted from money due to the Surety.

The Department will hold all money earned but not disbursed by the date of default. Upon resumption of the work after the default, all payments will be made to the Surety. All costs and charges incurred by the Department as a result of the default, including the cost of completing the work under the Contract, costs of maintaining traffic control devices, costs for other work deemed necessary, and any applicable liquidated damages or disincentives will be deducted from money due the Contractor for completed work. If these costs exceed the sum that would have been payable under the Contract, the Surety will be liable and pay the Department the balance of these costs in excess of the Contract price.

In case the costs incurred by the Department are less than the amount that would have been payable under the Contract if the work had been completed by the Contractor, the Department will be entitled to retain the difference.

If a Contractor defaults, the requirement that 30% of the work be done by the Contractor is suspended. However, Department approval of all subcontractors continues to be required. DBEs must continue to be used in accordance with the commitments previously approved by the Department.

If it is determined, after the Contractor is declared in default, that the Contractor was not in default, the rights and obligations of the parties will be the same as if the termination had been issued for the convenience of the public as provided in Article 8.7, "Termination of Contract."

8.7. Termination of Contract. The Department may terminate the Contract in whole or in part whenever:

- the Contractor is prevented from proceeding with the work as a direct result of an executive order of the President of the United States or the Governor of the State;
- the Contractor is prevented from proceeding with the work due to a national emergency, or when the work to be performed under the Contract is stopped, directly or indirectly, because of the freezing or diversion of materials, equipment or labor as the result of an order or a proclamation of the President of the United States;
- the Contractor is prevented from proceeding with the work due to an order of any federal authority;

- the Contractor is prevented from proceeding with the work by reason of a preliminary, special, or permanent restraining court order where the issuance of the restraining order is primarily caused by acts or omissions of persons or agencies other than the Contractor; or
 - the Department determines that termination of the Contract is in the best interest of the State or the public. This includes but is not limited to the discovery of significant hazardous material problems, right of way acquisition problems, or utility conflicts that would cause substantial delays or expense to the Contract.
- A. Procedures and Submittals.** The Engineer will provide written notice to the Contractor of termination specifying the extent of the termination and the effective date. Upon notice, immediately proceed in accordance with the following:
- stop work as specified in the notice;
 - place no further subcontracts or orders for materials, services, or facilities, except as necessary to complete a critical portion of the Contract, as approved by the Engineer;
 - terminate all subcontracts to the extent they relate to the work terminated;
 - complete performance of the work not terminated;
 - settle all outstanding liabilities and termination settlement proposals resulting from the termination for public convenience of the Contract;
 - create an inventory report, including all acceptable materials and products obtained for the Contract that have not been incorporated in the work that was terminated (include in the inventory report a description, quantity, location, source, cost, and payment status for each of the acceptable materials and products); and
 - take any action necessary, or that the Engineer may direct, for the protection and preservation of the materials and products related to the Contract that are in the possession of the Contractor and in which the Department has or may acquire an interest.
- B. Settlement Provisions.** Within 60 calendar days of the date of the notice of termination, submit a final termination settlement proposal, unless otherwise approved. The Engineer will prepare a change order that reduces the affected quantities of work and adds acceptable costs for termination. No claim for loss of anticipated profits will be considered. The Department will pay reasonable and verifiable termination costs including:
- all work completed at the unit bid price and partial payment for incomplete work;

8.8 to 8.8

- the percentage of Item 500, “Mobilization,” equivalent to the percentage of work complete or actual cost that can be supported by cost records, whichever is greater;
- expenses necessary for the preparation of termination settlement proposals and support data;
- the termination and settlement of subcontracts;
- storage, transportation, restocking, and other costs incurred necessary for the preservation, protection, or disposition of the termination inventory; and
- other expenses acceptable to the Department.

8.8. Subcontracting. Do not sublet any portion of a construction Contract without the Engineer’s written approval. A subcontract does not relieve any responsibility under the Contract and bonds. Ensure that all subcontracted work complies with all governing labor provisions.

A. Construction Contracts and Federally Funded Routine

Maintenance Contracts. Perform work with own organization on at least 30% of the total original Contract cost (25% if the Contractor is a Small Business Enterprise on a wholly State or local funded Contract), excluding any specialty items as determined by the Engineer. Specialty items are those that require highly specialized knowledge, abilities, or equipment not usually available in the contracting firm expected to bid on the proposed Contract as a whole.

Specialty items will be shown on the plans or as determined by the Engineer. Bid cost of specialty items performed by subcontractors will be deducted from the total original Contract cost before computing the required amount of work to be performed by the Contractor’s own organization.

The term “perform work with own organization” includes only:

- workers employed and paid directly by the Contractor or wholly owned subsidiary;
- equipment owned by the Contractor or wholly owned subsidiary;
- rented or leased equipment operated by the Contractor’s employees or wholly owned subsidiary’s employees;
- materials incorporated into the work if the majority of the value of the work involved in incorporating the material is performed by the Contractor’s own organization, including a wholly owned subsidiary’s organization; and
- labor provided by staff leasing firms licensed under Chapter 91 of the Texas Labor Code for nonsupervisory personnel if the Contractor or wholly owned subsidiary maintains direct control

over the activities of the leased employees and includes them in the weekly payrolls.

When staff leasing firms provide materials or equipment, they are considered subcontractors. In these instances, submit staff leasing firms for approval as a subcontractor.

Copies of cancelled checks and certified statements may be required to verify compliance with the requirements of this Section.

B. Routine Maintenance Contracts. The requirements for performing work with the Contractor's own organization do not apply to wholly State funded routine maintenance Contracts.

8.9. Workers and Equipment. Furnish suitable machinery, equipment, and construction forces for the proper prosecution of the work. Provide adequate lighting to address quality requirements and inspection of nighttime work.

At the written request of the Engineer, immediately remove from the work locations any employee or representative of the Contractor or a subcontractor who, in the opinion of the Engineer, does not perform work in a proper and skillful manner or who is disrespectful, intemperate, disorderly, uncooperative, or otherwise objectionable. Do not reinstate these individuals without the written consent of the Engineer.

The Engineer may suspend the work without suspending working day charges until the Contractor complies with these requests.

8.10. Minimum Wage Requirements for Routine Maintenance Contracts. The Contractor affirms by signing a wholly State or local funded routine maintenance Contract that employees, contract labor, and any subcontractor's employees are paid at least federal minimum wages as set forth in 29 CFR 206, unless otherwise shown on the plans.

Keep a copy of each payroll showing the name, number of hours worked each day, and the wage rate paid each employee, contract labor, and any subcontractor's employees together with a complete record of all deductions made from the wages. Upon request, submit copies of the payroll records. Progress payments may be withheld if any of these requirements are not satisfied.

ITEM 9
MEASUREMENT AND PAYMENT

9.1. Measurement of Quantities. The Engineer will measure all completed work using United States standard measures, unless otherwise specified.

- A. Linear Measurement.** Unless otherwise specified, all longitudinal measurements for surface areas will be made along the actual surface of the roadway and not horizontally. No deduction will be made for structures in the roadway having an area of 9 sq. ft. or less. For all transverse measurements for areas of base courses, surface courses, and pavements, the dimensions to be used in calculating the pay areas will be the neat dimensions and will not exceed those shown on plans, unless otherwise directed.
- B. Volume Measurement.** Transport materials measured for payment by volume in approved hauling vehicles. Display a unique identification mark on each vehicle. Furnish information necessary to calculate the volume capacity of each vehicle. The Engineer may require verification of volume through weight measurement. Use body shapes that allow the capacity to be verified. Load and level the load to the equipment's approved capacity. Loads not hauled in approved vehicles may be rejected.
- C. Weight Measurement.** Transport materials measured for payment by weight or truck measure in approved hauling vehicles. Furnish certified measurements, tare weights, and legal gross weight calculations for all haul units. Affix a permanent, legible number on the truck and on the trailer to correspond with the certified information. Furnish certified weights of loaded haul units transporting material if requested.

The material will be measured at the point of delivery. The cost of supplying these volume and weight capacities is subsidiary to the pertinent Item. For measurement by the ton, in the field, provide measurements in accordance with Item 520, "Weighing and Measuring Equipment," except for Items where ton measurements are measured by standard tables.

The Engineer may reject loads and suspend hauling operations for overloading.

- 1. Hauling on Routes Accessible to the Traveling Public.** For payment purposes on haul routes accessible to the traveling public, the net weight of the load will be calculated as follows:

- If the gross vehicle weight is less than the maximum allowed by state law, including applicable yearly weight tolerance permit, the net weight of the load will be determined by deducting the tare weight of the vehicle from the gross weight.
 - If the gross vehicle weight is more than the maximum allowed by state law, including applicable yearly weight tolerance permit, the net weight of the load will be determined by deducting the tare weight of the vehicle from the maximum gross weight allowed.
- 2. Hauling on Routes Not Accessible to the Traveling Public.** For payment purposes on haul routes that are not accessible to the traveling public where advance permission is obtained in writing from the Engineer,
- if the gross vehicle weight is less than the maximum allowed by the Engineer, including applicable yearly weight tolerance permit, the net weight of the load will be determined by deducting the tare weight of the vehicle from the gross weight and
 - if the gross vehicle weight is more than the maximum allowed by the Engineer, the net weight of the load will be determined by deducting the tare weight of the vehicle from the maximum gross weight allowed.

9.2. Plans Quantity Measurement. Plans quantities may or may not represent the exact quantity of work performed or material moved, handled, or placed during the execution of the Contract. The estimated bid quantities are designated as final payment quantities, unless revised by the governing specifications or this Article.

If the quantity measured as outlined under “Measurement” varies by more than 5% (or as stipulated under “Measurement” for specific Items) from the total estimated quantity for an individual Item originally shown in the Contract, an adjustment may be made to the quantity of authorized work done for payment purposes. The party to the Contract requesting the adjustment will provide field measurements and calculations showing the revised quantity. When approved, this revised quantity will constitute the final quantity for which payment will be made. Payment for revised quantity will be made at the unit price bid for that Item, except as provided for in Article 4.2, Changes in the Work.”

When quantities are revised by a change in design approved by the Department, by change order, or to correct an error on the plans, the plans

9.3 to 9.5

quantity will be increased or decreased by the amount involved in the change, and the 5% variance will apply to the new plans quantity.

If the total Contract quantity multiplied by the unit bid price for an individual Item is less than \$250 and the Item is not originally a plans quantity Item, then the Item may be paid as a plans quantity Item if the Engineer and Contractor agree in writing to fix the final quantity as a plans quantity.

For callout work or non-site-specific Contracts, plans quantity measurement requirements are not applicable.

9.3. Scope of Payment. Payment of the Contract unit price is full compensation for all materials, equipment, labor, tools, and supplies necessary to complete the Item of work under the Contract. Until final acceptance in accordance with Article 5.8, "Final Acceptance," assume liability for completing the work according to the plans and specifications and any loss or damage arising from the performance of the work or from the action of the elements, infringement of patent, trademark, or copyright, except as provided elsewhere in the Contract.

The Department will only pay for material incorporated into the work in accordance with the Contract. Payment of progress estimates will in no way affect the Contractor's obligation under the Contract to repair or replace any defective parts in the construction or to replace any defective materials used in the construction and to be responsible for all damages due to defects if the defects and damages are discovered on or before final inspection and acceptance of the work.

9.4. Payment for Extra Work. Payment for extra work directed, performed, and accepted will be made in accordance with Article 4.2, "Changes in the Work."

9.5. Force Account. The Engineer may provide for payment for extra work under Article 4.2, "Changes in the Work," on the force account basis, which includes compensation for the use of small tools, overhead expense, and profit. Execute a change order to establish labor and equipment rates and material costs to determine an estimated cost for the proposed work.

Payment for extra work directed on a force account basis will be as follows:

- A. Labor.** Compensation will be made for payroll rates for each hour that the labor and foremen or others approved by the Engineer are actually engaged in the work. In no case will the rate of wages be less than the minimum shown in the Contract for a particular category. An additional

25% of the above sum will be paid for overhead, superintendence, profit, and small tools.

- B. Insurance and Taxes.** An additional 55% of the labor cost, excluding the 25% compensation provided in Section 9.5.A, "Labor," will be paid as compensation for all insurance and taxes including the cost of premiums on public liability and workers compensation insurance, Social Security, and unemployment insurance taxes.
- C. Materials.** Compensation will be made for materials associated with the work based on actual delivered invoice costs, less any discount. An additional 25% of this sum will be paid as compensation for overhead and profit.
- D. Equipment.** Payment will be made for the established equipment hourly rates for each hour that the equipment is involved in the work. An additional 15% will be paid as compensation for overhead and profit not included in the rates.

Transportation cost for mobilizing equipment will be included if the equipment is mobilized from an off-site location.

If a rate has not been established for a particular piece of equipment in the *Rental Rate Blue Book*, the Engineer will allow a reasonable hourly rate, as agreed upon in writing before work is begun. This price will include operating costs.

The Department reserves the right to withhold payment for low production or lack of progress.

- 1. Contractor-Owned Equipment.** For Contractor-owned machinery, trucks, power tools, or other equipment necessary for use on force account work, use the *Rental Rate Blue Book* as modified by the following to establish hourly rates. Use the rates in effect for each section of the *Rental Rate Blue Book* at the time of use.

Compute the hourly rates as follows:

$$H = \frac{M \times R1 \times R2}{176} + OP$$

where:

H = Hourly Rate

M = Monthly Rate

R1 = Rate Adjustment Factor

R2 = Regional Adjustment Factor

OP = Operating Costs.

9.5 to 9.5

Payment for equipment will be made for the actual hours used in the work. Payment will not be made for time lost for equipment breakdowns, time spent to repair equipment, or time after equipment is no longer needed. If equipment is used intermittently while dedicated solely to the force account work, payment will be made for the duration the equipment is assigned to the work but no more than 8 hours per day.

2. **Equipment Not Owned by the Contractor.** If equipment is rented exclusively for force account work from a third party not owned by the Contractor, payment will be made at the invoice daily rental rate for each day the equipment is needed for the work. The Department reserves the right to limit the daily rate to comparable *Rental Rate Blue Book* rates. When the invoice specifies that the rental rate does not include fuel, lubricants, repairs, and servicing, the *Rental Rate Blue Book* hourly operating cost for each hour the equipment is operated will be added.
- E. **Subcontracting.** Additional compensation will be made for extra work performed by subcontractors under Article 4.2, "Changes in the Work," on the force account basis or based on actual invoice costs. An additional 5% compensation will be paid on subcontracted work for administrative cost and profit.
- F. **Law Enforcement.** For off-duty law enforcement, an additional 5% of the invoice cost for labor and equipment will be paid for administrative costs, superintendence, and profit.
- G. **Bond Cost.** An additional 1% of the total labor, material, equipment, and subcontracted compensation, including the additional compensation percentages provided by Sections A through F above, will be paid for the increase in bond cost due to the force account work.
- H. **Cost Records.** Maintain daily records of extra work completed on the force account basis. Provide copies of these records daily, signed by the Contractor's representative, for verification by the Department. Request payment for extra work performed on the force account basis, including copies of all applicable invoices, no later than the tenth day of the month following the month in which the work was performed.

If the Engineer directs extra work to be performed on a force account basis, and the estimated cost is less than \$10,000, submit for approval an invoice including the actual cost for materials, equipment, labor, tools, and incidentals necessary to complete the extra work. Also include on the invoice additional compensation allowed in this Article.

9.6. Progress Payments. The Engineer will prepare a monthly estimate of the amount of work performed, including materials in place. Payment of the monthly estimate is determined at the Contract Item prices less any withholdings or deductions in accordance with the Contract. Progress payments may be withheld for failure to comply with the Contract.

A. Retainage.

- 1. Routine Maintenance Contracts.** No retainage will be withheld from routine maintenance Contracts.
- 2. Construction Contracts.**
 - a. Contracts Without Recycled Materials.** For a Contract not using nonhazardous recycled materials (NRMs) as defined by Item 6, "Control of Materials," and DMS-11000, "Evaluating and Using Nonhazardous Recyclable Materials Guidelines," 5% retainage will be withheld from the total amount approved for payment until the completion and final acceptance.
 - b. Contracts With Recycled Materials.** For a Contract using NRMs, submit all required documentation before the first monthly progress estimate. For the Contract, 4% retainage will be withheld until the completion and final acceptance.
 - c. Partial Retainage Release.**
 - (1) Vegetative Establishment and Maintenance, Test and Performance Periods.** For a Contract that provides for a separate vegetative establishment and maintenance, and test and performance periods following the completion of all other construction in the Contract for all work locations, the Department may release a portion of the amount retained provided all other work is completed as determined by the Engineer. Before the release, all submittals and final quantities must be completed and accepted for all other work. An amount sufficient to ensure Contract compliance will be retained.
 - (2) Final Acceptance.** For a Contract on which recycled materials is used, 50% of the 4% retainage withheld will be released upon final acceptance. For a Contract without recycled materials, 60% of the 5% retainage withheld will be released upon final acceptance.
 - d. Final Retainage Release.** The remaining retainage will be released after all submittals are received and final quantities have been determined.

9.7 to 9.7

B. Payment Provisions for Subcontractors. Pay the subcontractor for work performed within 10 days after receiving payment for the work performed by the subcontractor. Also, pay any retainage on a subcontractor's work within 10 days after satisfactory completion of all of the subcontractor's work. Completed subcontractor work includes vegetative establishment, test, maintenance, performance, and other similar periods that are the responsibility of the subcontractor.

For the purpose of this Section, satisfactory completion is accomplished when:

- the subcontractor has fulfilled the Contract requirements of both the Department and the subcontract for the subcontracted work, including the submittal of all information required by the specifications and the Department; and
- the work done by the subcontractor has been inspected and approved by the Department and the final quantities of the subcontractor's work have been determined and agreed upon.

The inspection and approval of a subcontractor's work does not eliminate the Contractor's responsibilities for all the work as defined in Article 7.14, "Contractor's Responsibility for Work."

The Department may pursue actions against the Contractor, including withholding of estimates and suspending the work, for noncompliance with the subcontract requirements of this Section upon receipt of written notice with sufficient details showing the subcontractor has complied with contractual obligations as described in this Article.

These requirements apply to all tiers of subcontractors. Incorporate the provisions of this Article into all subcontract agreements.

9.7. Payment for Material on Hand (MOH). If payment for MOH is desired, request compensation for the invoice cost of acceptable nonperishable materials that have not been used in the work before the request, and that have been delivered to the work location or are in acceptable storage places. Nonperishable materials are those that do not have a shelf life or whose characteristics do not materially change when exposed to the elements. Include only materials that have been sampled, tested, approved, or certified, and are ready for incorporation into the work. Only materials which are completely constructed or fabricated on the Contractor's order for a specific Contract and are so marked and on which an approved test report has been issued are eligible. Payment for MOH may include the following types of Items: concrete traffic barrier, precast concrete box culverts, concrete piling, reinforced concrete pipe, and

illumination poles. Any repairs required after fabricated materials have been approved for storage shall require approval of the Engineer before being made and shall be made at the Contractor's expense. Include only those materials that have an invoice cost of at least \$1,000 in the request for MOH payment.

For multiple work order Contracts, payment for MOH will only be made for materials authorized for purchase by the work order or by written approval of the Engineer.

If the request is acceptable, the Engineer will include payment for MOH in a progress payment. Payment for MOH does not constitute acceptance of the materials. Payment will not exceed the actual cost of the material as established by invoice, or the total cost for the associated Item less reasonable placement costs, whichever is less. Materials for which the Contractor does not have a paid invoice within 60 days will not be eligible for payment and will be removed from the estimate. Payment may be limited to a portion of the invoice cost or unit price if shown elsewhere in the Contract. Payment for precast products fabricated or constructed by the Contractor for which invoices or freight bills are not available may be made based on statements of actual cost.

Submit the request on forms provided by the Department. These forms may be electronically reproduced, provided they are in the same format and contain all the required information and certifications. Continue to submit monthly MOH forms until the total value of MOH is \$0.

By submitting a request for MOH payment, the Contractor expressly authorizes the Department to audit MOH records, and to perform process reviews of the record-keeping system. If the Department determines noncompliance with any of the requirements of this provision, the Department may exclude payment for any or all MOH for the duration of the Contract.

Maintain all records relating to MOH payment until final acceptance. Provide these records to the Engineer upon request.

9.8. Final Payment. When the Contract has been completed, all work has been approved, final acceptance has been made in accordance with Article 5.8, "Final Acceptance," and Contractor submittals have been received, the Engineer will prepare a final estimate for payment showing the total quantity of work completed and the money owed the Contractor. The final payment will reflect the entire sum due, less any sums previously paid.

100 ITEMS — EARTH WORK AND LANDSCAPE**ITEM 100****PREPARING RIGHT OF WAY**

100.1. Description. Prepare the right of way and designated easements for construction operations by removing and disposing of all obstructions when removal of such obstructions is not specifically shown on the plans to be paid by other Items.

100.2. Construction. Protect designated features on the right of way and prune trees and shrubs as directed. Do not park equipment, service equipment, store materials, or disturb the root area under the branches of trees designated for preservation. When shown on the plans, treat cuts on trees with an approved tree wound dressing within 20 min. of making a pruning cut or otherwise causing damage to the tree. Follow all local and state regulations when burning. If burning of brush is approved, pile and burn at approved locations. When working in state or national forests or parks, coordinate work with state and federal authorities. Testing, removal, and disposal of hazardous materials will be in accordance with Article 6.10, “Hazardous Materials.”

Clear areas shown on the plans of all obstructions, except those landscape features that are to be preserved. Such obstructions include but are not limited to remains of houses and other structures, foundations, floor slabs, concrete, brick, lumber, plaster, septic tank drain fields, basements, abandoned utility pipes or conduits, equipment, fences, retaining walls, and other items as specified on the plans. Remove vegetation and other landscape features not designated for preservation, curb and gutter, driveways, paved parking areas, miscellaneous stone, sidewalks, drainage structures, manholes, inlets, abandoned railroad tracks, scrap iron, and debris, whether above or below ground. Removal of live utility facilities is not included in this Item. Remove culverts, storm sewers, manholes, and inlets in proper sequence to maintain traffic and drainage.

In areas receiving embankment, remove obstructions not designated for preservation to 2 ft. below natural ground. In areas to be excavated, remove obstructions to 2 ft. below the excavation level. In all other areas, remove obstructions to 1 ft. below natural ground. When allowed by the plans or directed, cut trees and stumps off to ground level. Plug the remaining ends of abandoned underground structures over 3 in. in diameter with concrete to form a tight closure. Backfill, compact, and restore areas where obstructions

100.3 to 103.2

have been removed, unless otherwise directed. Use approved material for backfilling. Dispose of wells in accordance with Item 103, "Disposal of Wells."

Accept ownership, unless otherwise directed, and dispose of removed materials and debris at locations off the right of way in accordance with local, state, and federal requirements.

100.3. Measurement. This Item will be measured by the acre; by the 100-foot station, regardless of the width of the right of way; or by each tree removed.

100.4. Payment. For "acre" and "station" measurement, the work performed in accordance with this Item and measured as provided under "Measurement" will be paid for at the unit price bid for "Preparing Right of Way." For "each" measurement, the work performed in accordance with this Item and measured as provided under "Measurement" will be paid for at the unit price bid for "Preparing Right of Way (Tree)" of the diameter specified. This price is full compensation for pruning of designated trees and shrubs; removal and disposal of structures and obstructions; backfilling of holes; furnishing and placing concrete for plugs; and equipment, labor, tools, and incidentals.

Total payment of this Item will not exceed 10% of the original contract amount until final acceptance or the initial release of retainage. The remainder will be paid on the estimate after the partial release of retainage.

ITEM 103

DISPOSAL OF WELLS

103.1. Description. Remove and dispose of contaminated and uncontaminated water, petroleum, or sulfur wells. Remove appurtenances, seal and plug wells, and restore the area. Prepare and file required documents with applicable agencies.

103.2. Construction. Follow legal responsibilities, construction requirements, and methods in accordance with Articles 7.1, "Laws to be Observed," and 7.2, "Permits, Licenses and Taxes."

Remove all pump equipment to 3 ft. below the finished subgrade or the existing grade, whichever is lower, and within construction limits. Pump equipment includes pump, piping, motor, housing, well structures,

foundations, flumes, windmills, casing, and other projecting objects associated with the well.

All removed items and appurtenance become the property of the Contractor, excluding existing contaminated soil and liquids, after necessary cleaning and disassembling. Dispose of these items in accordance with applicable laws and regulations. Testing, removal, and disposal of hazardous materials will be in accordance with Article 6.10, "Hazardous Materials."

Cap remaining pipe. When required by the TCEQ, the TDLR, or the RRC, submit a "Plugging Report" to the appropriate agency. Furnish a copy to the Engineer. Backfill in accordance with Article 100.2, "Construction," after removing all appurtenances.

- A. Water Wells.** Remove all removable casing from water wells, including dry wells and abandoned wells. Pressure-fill the well with a mixture of hydraulic cement and water at a rate of not more than 7 gal. of water per sack of cement from the bottom of the well to the natural ground surface or 3 ft. below the finished subgrade, whichever is lower, according to the requirements of the TDLR. Alternative procedures require written approval by TDLR and the Engineer.

Plug any well located in a cut section up to the proposed earthwork elevation before excavating the cut. Immediately after plugging a well in a cut section, backfill the remainder of the well above the proposed earthwork elevation with earth.

- B. Petroleum and Sulfur Wells.** Have a contractor from the RRC-approved list plug the well. Empty the contents of petroleum or sulfur wells into approved containers according to applicable regulations. Transport and dispose of the filled containers at an approved disposal facility or recycling center according to applicable regulations. Approved plugging methods include protecting water-bearing strata with cement plugs when shown on the plans, or completely cementing the well.

103.3. Measurement. This Item will be measured by each properly plugged and disposed well.

103.4. Payment. The work performed and materials furnished in accordance with this Item and measured as provided under "Measurement" will be paid for at the unit price bid for "Disposal of Water Wells" or "Disposal of Petroleum or Sulfur Wells." This price is full compensation for removing and disposing of appurtenances; plugging; furnishing records;

103.4 to 104.4

furnishing and placing any material or items; site restoration; and equipment, labor, tools, and incidentals.

ITEM 104 REMOVING CONCRETE

104.1. Description. Break, remove, and salvage or dispose of existing hydraulic cement concrete.

104.2. Construction. Remove existing hydraulic cement concrete from locations shown on the plans. Avoid damaging concrete that will remain in place. Saw-cut and remove the existing concrete to neat lines. Replace any concrete damaged by the Contractor at no expense to the Department. Unless otherwise shown on the plans, accept ownership and properly dispose of broken concrete in accordance with federal, state, and local regulations.

104.3. Measurement. Removing concrete pavement, floors, porches, patios, riprap, medians, foundations, sidewalks, driveways, and other appurtenances will be measured by the square yard (regardless of thickness) or by the cubic yard of calculated volume, in its original position.

Removing curb, curb and gutter, and concrete traffic barrier will be measured by the foot in its original position. The removal of monolithic concrete curb or dowelled concrete curb will be included in the concrete pavement measurement.

Removing retaining walls will be measured by the square yard along the front face from the top of the wall to the top of the footing.

This is a plans quantity measurement Item. The quantity to be paid is the quantity shown in the proposal, unless modified by Article 9.2, "Plans Quantity Measurement." Additional measurements or calculations will be made if adjustments of quantities are required.

104.4. Payment. The work performed and materials furnished in accordance with this Item and measured as provided under "Measurement" will be paid for at the unit price bid for "Removing Concrete" of the type specified. This price is full compensation for breaking the concrete; loading, hauling and salvaging or disposing of the material; and equipment, labor, tools, and incidentals.

Removing retaining wall footings will not be paid for directly, but will be considered subsidiary to this Item.

ITEM 105

REMOVING STABILIZED BASE AND ASPHALT PAVEMENT

105.1. Description. Break, remove, and store or dispose of existing asphalt pavement or stabilized base materials.

105.2. Construction. Break material retained by the Department into pieces not larger than 24 in. Remove existing asphalt pavement prior to disturbing stabilized base. Avoid contamination of the asphalt materials and damage to adjacent areas. Repair material damaged by operations outside the designated locations.

When shown on the plans and as directed, stockpile materials designated salvageable at designated sites. Prepare stockpile site by removing vegetation and trash and by providing for proper drainage. Dispose of materials not designated as salvageable in accordance with federal, state, and local regulations.

105.3. Measurement. This Item will be measured by the 100-ft. station along the baseline of each roadbed, by the square yard of existing stabilized base and asphalt pavement in its original position, or by the cubic yard of existing stabilized base and asphalt pavement in its original position, as calculated by the average end area method. Square yard and cubic yard measurement will be established by the widths and depths shown in the plans and the lengths measured in the field.

105.4. Payment. The work performed in accordance with this Item and measured as provided under “Measurement” will be paid for at the unit price bid for “Removing Stabilized Base and Asphalt Pavement,” of the depth specified. This price is full compensation for breaking the material, loading, hauling, unloading, stockpiling or disposing; repair to areas outside designated locations for removal; and equipment, labor, tools, and incidentals.

106.1 to 110.2

ITEM 106

OBLITERATING ABANDONED ROAD

106.1. Description. Obliterate designated sections of abandoned road.

106.2. Construction. Strip and windrow existing topsoil before shaping operations. Remove asphaltic pavement in accordance with applicable item. Remove material designated as salvageable in accordance with applicable items. Remove abandoned structures unless otherwise shown on the plans. Scarify and mix the abandoned roadbed with soil and blade to produce a smooth, uniform appearance. Fill, cut, and shape the designated sections of the abandoned road to blend into the surrounding terrain. Eliminate ditches except where needed to facilitate drainage. Cover disturbed areas with topsoil after shaping operations to facilitate establishment of vegetation.

106.3. Measurement. This Item will be measured by the 100-ft. station along the baseline of the abandoned roadway.

106.4. Payment. The work performed in accordance with this Item and measured as provided under “Measurement” will be paid for at the unit price bid for “Obliterating Abandoned Road.” This price is full compensation for salvaging and replacing topsoil; stockpiling or disposal of materials; removal of abandoned structures; scarifying, mixing, and shaping abandoned road; furnishing and operating equipment, and labor, tools, and incidentals.

ITEM 110

EXCAVATION

110.1. Description. Excavate areas as shown on the plans or as directed. Remove materials encountered to the lines, grades, and typical sections shown on the plans and cross-sections.

110.2. Construction. Accept ownership of unsuitable or excess material and dispose of material in accordance with local, state, and federal regulations at locations outside the right of way.

Maintain drainage in the excavated area to avoid damage to the roadway section. Correct any damage to the subgrade caused by weather, at no additional cost to the Department.

Shape slopes to avoid loosening material below or outside the proposed grades. Remove and dispose of slides as directed.

A. Rock Cuts. Excavate to finish subgrade. Manipulate and compact subgrade in accordance with Article 132.3.D, “Compaction Methods,” unless excavation is to clean homogenous rock at finish subgrade elevation. If excavation extends below finish subgrade, use approved embankment material compacted in accordance with Article 132.3.D to replace undercut material at no additional cost.

B. Earth Cuts. Excavate to finish subgrade. In areas where base or pavement structure will be placed on subgrade, scarify subgrade to a uniform depth at least 6 in. below finish subgrade elevation. Manipulate and compact subgrade in accordance with Article 132.3.D, “Compaction Methods.”

If unsuitable material is encountered below subgrade elevations, take corrective measures as directed. Drying required deeper than 6 in. below subgrade elevation will be paid for in accordance with Article 9.4, “Payment for Extra Work.” Excavation and replacement of unsuitable material below subgrade elevations will be performed and paid for in accordance with the applicable bid items. However, if Item 132, “Embankment,” is not included in the Contract, payment for replacement of unsuitable material will be paid for in accordance with Article 9.4.

C. Subgrade Tolerances. For turnkey construction, excavate to within 1/2 in. in cross-section and 1/2 in. in 16 ft. measured longitudinally. For staged construction, excavate to within 0.1 ft. in cross-section and 0.1 ft. in 16 ft. measured longitudinally.

110.3. Measurement. This Item will be measured by the cubic yard in its original position as computed by the method of average end areas.

This is a plans quantity measurement Item. The quantity to be paid is the quantity shown in the proposal unless modified by Article 9.2, “Plans Quantity Measurement.” Additional measurements or calculations will be made if adjustments of quantities are required.

Limits of measurement for excavation in retaining wall areas will be as shown on the plans.

Shrinkage or swelling factors will not be considered in determining the calculated quantities.

110.4. Payment. The work performed and materials furnished in accordance with this Item and measured as provided under “Measurement” will be paid for at the unit price bid for “Excavation (Roadway),” “Excavation (Channel),” “Excavation (Special),” or “Excavation (Roadway

110.4 to 112.3

and Channel).” This price is full compensation for authorized excavation; drying; undercutting subgrade and reworking or replacing the undercut material in rock cuts; hauling; disposal of material not used elsewhere on the project; scarification and compaction; and equipment, labor, materials, tools, and incidentals.

When a slide not due to the Contractor’s negligence or operation occurs, payments for removal and disposal of the slide material will be in accordance with Article 9.4, “Payment for Extra Work.” Excavation in backfill areas of retaining walls will not be measured or paid for directly but will be subsidiary to pertinent Items.

ITEM 112 SUBGRADE WIDENING

112.1. Description. Widen the existing subgrade in accordance with the typical sections.

112.2. Materials. Furnish water in accordance with Article 204.2, “Materials.”

112.3. Construction.

- A. Preparation of Embankment.** Scarify to a depth of at least 6 in. into existing adjacent embankment slopes before fill is placed.
- B. Pavement Structure Removal.** Remove material along the edge of the existing pavement. Provide a smooth vertical cut unless otherwise shown on the plans. Conform to the typical sections for the limits of removal unless directed otherwise. Accept ownership of excess material not used in the construction of the subgrade widening. Dispose of excess material in accordance with federal, state, and local regulations.
- C. Widening.** In cut sections, remove material and move to fill sections within the project. Use material from cut sections for embankment. In fill sections, place the material in successive lifts to the line and grades shown on the typical sections. Provide additional embankment in accordance with the applicable bid item or Article 9.4, “Payment for Extra Work,” if all excavation has been performed and additional embankment is required to complete the work.
- D. Compaction.** Compact the widened subgrade in accordance with Article 132.3, “Construction.”

112.4. Measurement. This Item will be measured by the 100-ft. station along the baseline of each roadbed.

This is a plans quantity measurement Item. The quantity to be paid is the quantity shown in the proposal, unless modified by Article 9.2, “Plans Quantity Measurement.” Additional measurements or calculations will be made if adjustments of quantities are required.

112.5. Payment. The work performed and materials furnished in accordance with this Item and measured as provided under “Measurement” will be paid for at the unit price bid for “Subgrade Widening (Ordinary Compaction)” or “Subgrade Widening (Density Control).” This price is full compensation for excavation; hauling of embankment material from cuts to fills; finishing of the subgrade widening; hauling and disposing of excess excavated material; furnishing and operating equipment; scarifying; shaping; and labor, fuel, materials, tools, and incidentals.

No payment will be made for thickness or width exceeding that shown on the typical sections. “Sprinkling” and “Rolling” will not be paid for directly but will be considered subsidiary to this Item.

Corrections of unstable areas in the widened subgrade will be at the Contractor’s expense. In a cut section, work involved in removing and replacing unsuitable material encountered below the finished subgrade will be paid for as specified under Item 110, “Excavation,” when included; otherwise it will be paid for under Article 9.4, “Payment for Extra Work.”

ITEM 132

EMBANKMENT

132.1. Description. Furnish, place, and compact materials for construction of roadways, embankments, levees, dikes, or any designated section of the roadway where additional material is required.

132.2. Materials. Furnish approved material capable of forming a stable embankment from required excavation in the areas shown on the plans or from sources outside the right of way. Provide 1 or more of the following types as shown on the plans:

- **Type A.** Granular material that is free from vegetation or other objectionable material and meets the requirements of Table 1.

132.3 to 132.3

Table 1
Testing Requirements

Property	Test Method	Specification Limit
Liquid limit	Tex-104-E	≤ 45
Plasticity index (PI)	Tex-106-E	≤ 15
Bar linear shrinkage	Tex-107-E	≥ 2

The Linear Shrinkage test only needs to be performed as indicated in Tex-104-E.

- **Type B.** Materials such as rock, loam, clay, or other approved materials.
- **Type C.** Material meeting the specification requirements shown on the plans.
- **Type D.** Material from required excavation areas shown on the plans.

Retaining wall backfill material must meet the requirements of the pertinent retaining wall Items.

132.3. Construction. Meet the requirements of Item 7, “Legal Relations and Responsibilities to the Public,” when off right of way sources are used. To allow for required testing, notify the Engineer before opening a material source. Complete preparation of the right of way, in accordance with Item 100, “Preparing Right of Way,” for areas to receive embankment.

Backfill tree-stump holes or other minor excavations with approved material and tamp. Restore the ground surface, including any material disked loose or washed out, to its original slope. Compact the ground surface by sprinkling in accordance with Item 204, “Sprinkling,” and by rolling using equipment complying with Item 210, “Rolling,” when directed.

Scarify and loosen the unpaved surface areas, except rock, to a depth of at least 6 in., unless otherwise shown on the plans. Bench slopes before placing material. Begin placement of material at the toe of slopes. Do not place trees, stumps, roots, vegetation, or other objectionable material in the embankment. Simultaneously recompact scarified material with the placed embankment material. Do not exceed the layer depth specified in Section 132.3.D, “Compaction Methods.”

Construct embankments to the grade and sections shown on the plans. Construct the embankment in layers approximately parallel to the finished grade for the full width of the individual roadway cross sections, unless otherwise shown on the plans. Ensure that each section of the embankment

conforms to the detailed sections or slopes. Maintain the finished section, density, and grade until the project is accepted.

- A. Earth Embankments.** Earth embankment is mainly composed of material other than rock. Construct embankments in successive layers, evenly distributing materials in lengths suited for sprinkling and rolling.

Obtain approval to incorporate rock and broken concrete produced by the construction project in the lower layers of the embankment. When the size of approved rock or broken concrete exceeds the layer thickness requirements in Section 132.3.D, "Compaction Methods," place the rock and concrete outside the limits of the completed roadbed. Cut and remove all exposed reinforcing steel from the broken concrete.

Move the material dumped in piles or windrows by blading or by similar methods and incorporate it into uniform layers. Featheredge or mix abutting layers of dissimilar material for at least 100 ft. to ensure there are no abrupt changes in the material. Break down clods or lumps of material and mix embankment until a uniform material is attained.

Apply water free of industrial wastes and other objectionable matter to achieve the uniform moisture content specified for compaction.

When ordinary compaction is specified, roll and sprinkle each embankment layer in accordance with Section 132.3.D.1, "Ordinary Compaction." When density control is specified, compact the layer to the required density in accordance with Section 132.3.D.2, "Density Control."

- B. Rock Embankments.** Rock embankment is mainly composed of rock. Construct rock embankments in successive layers for the full width of the roadway cross-section with a depth of 18 in. or less. Increase the layer depth for large rock sizes as approved. Do not exceed a depth of 2-1/2 ft. in any case. Fill voids created by the large stone matrix with smaller stones during the placement and filling operations.

Ensure the depth of the embankment layer is greater than the maximum dimension of any rock. Do not place rock greater than 2 ft. in its maximum dimension, unless otherwise approved. Construct the final layer with graded material so that the density and uniformity is in accordance with Section 132.3.D, "Compaction Methods." Break up exposed oversized material as approved.

When ordinary compaction is specified, roll and sprinkle each embankment layer in accordance with Section 132.3.D.1, "Ordinary Compaction." When density control is specified, compact each layer to

132.3 to 132.3

the required density in accordance with Section 132.3.D.2, “Density Control.” When directed, proof-roll each rock layer where density testing is not possible, in accordance with Item 216, “Proof Rolling,” to ensure proper compaction.

- C. **Embankments Adjacent to Culverts and Bridges.** Compact embankments adjacent to culverts and bridges in accordance with Item 400, “Excavation and Backfill for Structures.”
- D. **Compaction Methods.** Begin rolling longitudinally at the sides and proceed toward the center, overlapping on successive trips by at least 1/2 the width of the roller. On super elevated curves, begin rolling at the lower side and progress toward the high side. Alternate roller trips to attain slightly different lengths. Compact embankments in accordance with one of the following methods as shown on the plans:
 - 1. **Ordinary Compaction.** Use approved rolling equipment complying with Item 210, “Rolling,” to compact each layer. The plans or the Engineer may require specific equipment. Do not allow the loose depth of any layer to exceed 8 in., unless otherwise approved. Before and during rolling operations, bring each layer to the moisture content directed. Compact each layer until there is no evidence of further consolidation. Maintain a level layer to ensure uniform compaction. If the required stability or finish is lost for any reason, recompact and refinish the subgrade at no additional expense to the Department.
 - 2. **Density Control.** Compact each layer to the required density using equipment complying with Item 210, “Rolling.” Determine the maximum lift thickness based on the ability of the compacting operation and equipment to meet the required density. Do not exceed layer thickness of 16 in. loose or 12 in. compacted material, unless otherwise approved. Maintain a level layer to ensure uniform compaction.

The Engineer will use Tex-114-E to determine the maximum dry density (D_a) and optimum moisture content (W_{opt}). Meet the requirements for field density and moisture content in Table 2, unless otherwise shown on the plans.

Table 2
Field Density Control Requirements

Description	Density ¹	Moisture Content ¹
	Tex-115-E	
PI ≤ 15	≥ 98% D _a	
15 < PI ≤ 35	≥ 98% D _a and ≤ 102% D _a	≥ W _{opt.}
PI > 35	≥ 95% D _a and ≤ 100% D _a	≥ W _{opt.}

Each layer is subject to testing by the Engineer for density and moisture content. During compaction, the moisture content of the soil should not exceed the value shown on the moisture-density curve, above optimum, required to achieve

- 98% dry density for soils with a PI greater than 15 but less than or equal to 35 or
- 95% dry density for soils with PI greater than 35.

When required, remove small areas of the layer to allow for density tests. Replace the removed material and recompact at no additional expense to the Department. Proof-roll in accordance with Item 216, “Proof Rolling,” when shown on the plans or as directed. Correct soft spots as directed.

E. Maintenance of Moisture and Reworking. Maintain the density and moisture content once all requirements in Table 2 are met. For soils with a PI greater than 15, maintain the moisture content no lower than 4 percentage points below optimum. Rework the material to obtain the specified compaction when the material loses the required stability, density, moisture, or finish. Alter the compaction methods and procedures on subsequent work to obtain specified density as directed.

F. Acceptance Criteria.

1. Grade Tolerances.

- a. Staged Construction.** Grade to within 0.1 ft. in the cross-section and 0.1 ft. in 16 ft. measured longitudinally.
- b. Turnkey Construction.** Grade to within 1/2 in. in the cross-section and 1/2 in. in 16 ft. measured longitudinally.

2. Gradation Tolerances. When gradation requirements are shown on the plans, material is acceptable when not more than 1 of the 5

132.4 to 132.5

most recent gradation tests is outside the specified limits on any individual sieve by more than 5 percentage points.

3. **Density Tolerances.** Compaction work is acceptable when not more than 1 of the 5 most recent density tests is outside the specified density limits, and no test is outside the limits by more than 3 lb. per cubic foot.
4. **Plasticity Tolerances.** Material is acceptable when not more than 1 of the 5 most recent PI tests is outside the specified limit by no more than 2 points.

132.4. Measurement. Embankment will be measured by the cubic yard. Measurement will be further defined for payment as follows:

- A. **Final.** The cubic yard will be measured in its final position using the average end area method. The volume is computed between the original ground surface or the surface upon which the embankment is to be constructed and the lines, grades, and slopes of the embankment. In areas of salvaged topsoil, payment for embankment will be made in accordance with Item 160, "Topsoil." Shrinkage or swell factors will not be considered in determining the calculated quantities.
- B. **Original.** The cubic yard will be measured in its original and natural position using the average end area method.
- C. **Vehicle.** The cubic yard will be measured in vehicles at the point of delivery.

When measured by the cubic yard in its final position, this is a plans quantity measurement item. The quantity to be paid is the quantity shown in the proposal, unless modified by Article 9.2, "Plans Quantity Measurement." Additional measurements or calculations will be made if adjustments of quantities are required.

Shrinkage or swell factors are the Contractor's responsibility. When shown on the plans, factors are for informational purposes only.

Measurement of retaining wall backfill in embankment areas is paid for as embankment, unless otherwise shown on plans. Limits of measurement for embankment in retaining wall areas are shown on the plans.

132.5. Payment. The work performed and materials furnished in accordance with this Item and measured as provided under "Measurement" will be paid for at the unit price bid for "Embankment (Final)," "Embankment (Original)," or "Embankment (Vehicle)," of the compaction method and type specified. This price is full compensation for furnishing

embankment; hauling; placing, compacting, finishing, and reworking; disposal of waste material; and equipment, labor, tools, and incidentals.

When proof rolling is directed, it will be paid for in accordance with Item 216, "Proof Rolling."

All sprinkling and rolling, except proof rolling, will not be paid for directly, but will be considered subsidiary to this Item, unless otherwise shown on the plans.

Where subgrade is constructed under this contract, correction of soft spots in the subgrade will be at the Contractor's expense. Where subgrade is not constructed under this contract, correction of soft spots in the subgrade will be paid in accordance with Article 9.4, "Payment for Extra Work."

ITEM 134

BACKFILLING PAVEMENT EDGES

134.1. Description. Backfill pavement edges in conformance with the typical sections shown on the plans.

134.2. Materials.

- A. Backfill Material.** Use backfill material capable of sustaining vegetation unless otherwise specified on the plans. Furnish backfill material of one of the following types:
1. **Type A.** Backfill secured from a source outside the right of way and according to the requirements as shown on the plans.
 2. **Type B.** Backfill secured from within the existing right of way as shown on the plans or as directed.
 3. **Type C.** Mulch sodding backfill secured from an approved source in accordance with Article 162.2.B, "Mulch Sod."
- B. Emulsified Asphalt.** Furnish the type specified on the plans and meeting the requirements of Item 300, "Asphalts, Oils, and Emulsions."
- C. Fertilizer.** Furnish fertilizer in accordance with Article 166.2, "Materials," if specified on the plans.
- D. Water.** Furnish water required for proper compaction, promotion of plant growth, or emulsion dilution in accordance with Article 168.2, "Materials."

134.3. Construction. Haul the backfill material to the required location before placing the finish surface course unless directed otherwise. After

134.3 to 150.1

placing the finish surface course, spread, compact, and shape the backfill material in accordance with the typical sections.

- A. Types A and B Backfill.** After placing the finish surface course, bring the backfill material to the approved moisture content. Shape to the lines and grades shown on the plans, and compact as directed. After compacting the backfill, blade the roadway side-slopes to a smooth surface.
- B. Type C Backfill.** Place mulch sod in a uniform windrow, and keep moist as directed. After placing the finish surface course, cultivate the area to receive mulch sod to a depth of 4 in. Blade and shape the mulch sod across the area in varying depths as shown on the typical sections to produce a smooth and uniform slope. Roll with a light roller or other suitable equipment. After applying fertilizer, moisten to the maximum depth of the backfill as directed.
- C. Fertilizer.** When fertilizer is specified on the plans, after final finishing of the backfill material, distribute the fertilizer uniformly in accordance with Article 166.3, "Construction." After applying fertilizer, moisten to a depth of 4in. or to the maximum depth of the backfill, whichever is less.
- D. Emulsified Asphalt.** When specified on the plans, after final finishing of the backfill material, apply the emulsified asphalt mixture in accordance with Article 314.4, "Construction," at the specified amount and rate of application as shown on the plans.

134.4. Measurement. This Item will be measured by the 100-ft. station along the baseline of each roadbed.

134.5. Payment. The work performed and materials furnished in accordance with this Item and measured as provided under "Measurement" will be paid for at the unit price bid for "Backfill" of the type specified. This price is full compensation for furnishing the emulsified asphalt, water, fertilizer, and backfill material; and for equipment, labor, materials, tools, and incidentals.

ITEM 150 BLADING

150.1. Description. Blade portions of the project limits as shown on the plans or as directed.

150.2. Equipment. Provide equipment able to effectively produce the desired results. When work is measured and paid by the number of hours of blading, use a dual or four-wheel drive power maintainer equipped with pneumatic tires, a blade of at least 12 ft. in length, and a wheelbase of not less than 16 ft. If the maintainer is not equipped with a scarifier attachment, provide a scarifier.

150.3. Construction. Blade all areas to the section, line and grade shown on the plans. Use a scarifier when necessary to loosen materials prior to blading. Use hand methods or other means around structures, trees, and other obstructions if doing the work with a blade is impractical. Do not drag, push, or scrape material along or across completed pavement.

150.4. Measurement. This Item will be measured by the 100-foot station, along the base line of each roadbed or by the number of hours of blading, including scarifying, performed. Roadbed is defined in Item 1, "Definition of Terms."

150.5. Payment. The work performed in accordance with this Item and measured as provided under "Measurement" will be paid for at the unit price bid for "Blading." This price is full compensation for furnishing and operating equipment and for labor, materials, tools, and incidentals.

Work done by hand labor methods adjacent to structures, trees, and other obstructions is not paid for directly, but will be considered subsidiary to this Item. Work performed under this Item will not include work specified for payment under other Items.

ITEM 152

ROAD GRADER WORK

152.1. Description. Construct subgrade and adjacent slopes. Construct portions of the roadway according to the typical sections as shown on the plans where finished grade is uncontrolled. Move earthwork of minor volumes and for short distances only. Move earthwork within the limits as shown on the plans and in at least 500-ft. sections, except on bridge projects.

152.2. Equipment. Provide equipment in accordance with Article 150.2, "Equipment."

152.3 to 154.3

152.3. Construction. Remove or rework unsuitable or unstable materials in accordance with Article 110.2, "Construction," or as directed. Grade the roadway and shape to the typical sections shown on the plans. Finish to a profile uniform and consistent with the topography. Scarify existing natural ground or roadbed and compact in accordance with the method shown on the plans and as outlined in Article 132.3, "Construction." When shown on the plans, "Road Grader Work" will be supplemented by Item 154, "Scraper Work," Item 156, "Bulldozer Work," or both. Perform work in accordance with the requirements of the governing Item.

152.4. Measurement. This Item will be measured by the 100-ft. station, as measured along the baseline of each roadbed, or by the square yard.

152.5. Payment. The work performed in accordance with this Item and measured as provided under "Measurement" will be paid for at the unit price bid for "Road Grader Work (Ordinary Compaction)" or "Road Grader Work (Density Control)." This price is full compensation for furnishing and operating equipment and for labor, materials, tools, and incidentals.

"Sprinkling" and "Rolling" will not be paid for directly but will be subsidiary to this Item. All work involved in removing and replacing or reworking unsuitable or unstable material will be paid for as specified under Item 110, "Excavation," when the Contract includes bid items governed by Item 110; otherwise it will be paid for under Article 9.4, "Payment for Extra Work." The work performed under this Item will not include work specified for payment under other Items.

ITEM 154 SCRAPER WORK

154.1. Description. Excavate, remove, utilize, or dispose of materials with a scraper. Construct, shape, and rough in earthwork in conformity with the required lines, grades, and typical sections as shown on the plans, or as directed.

154.2. Equipment. Use a scraper with a minimum 7.5-cu. yd. flush capacity. Provide a scraper capable of self-loading, or provide power equipment for the scraper to load to capacity. A scraper unit consists of the scraper and any power units necessary.

154.3. Construction. Perform "Scraper Work" on the areas shown on the plans or as directed. Use suitable excavated materials, including topsoil, for

constructing the required roadway sections. Compact embankment in accordance with methods shown on the plans and as outlined in Article 132.3, "Construction." All excavated material becomes the property of the Contractor, unless otherwise shown on the plans. Properly dispose of excess excavated material in accordance with federal, state, and local requirements at locations outside the right of way.

Where plans designate "Scraper Work" and either "Blading" or "Road Grader Work" within the same limits, rough in with "Scraper Work." Finish in accordance with Item 150, "Blading," or Item 152, "Road Grader Work."

154.4. Measurement. This Item will be measured by the cubic yard hour. A scraper unit cubic yard hour is the flush capacity of the scraper in cubic yards or 70% of the manufacturer's heaped capacity, whichever is less, multiplied by the actual number of hours of scraper work performed.

154.5. Payment. The work performed in accordance with this Item and measured as provided under "Measurement" will be paid for at the unit price bid for "Scraper Work (Ordinary Compaction)" or "Scraper Work (Density Control)." This price is full compensation for equipment, material removal and disposal, hauling, labor, materials, tools, and incidentals.

"Sprinkling" and "Rolling" will not be paid for directly, but will be subsidiary to this Item. The work performed under this Item will not include work specified for payment under other Items.

ITEM 156

BULLDOZER WORK

156.1. Description. Excavate, remove, utilize, or dispose of materials with a bulldozer. Construct, shape, and finish earthwork in conformity with the required lines, grades, and typical cross sections as shown on the plans, or as directed.

156.2. Equipment. Use a tractor, crawler or rubber tired type, with a blade attachment. Use a scarifier or ripper with the required tractor when necessary. The blade attachment must be at least 8 ft. long. Use equipment of the type specified on the plans, meeting the following requirements:

- A. Type A.** Manufacturer's rated net flywheel power of less than 150 horsepower based on SAE standard J1349.
- B. Type B.** Manufacturer's rated net flywheel power of 150 or greater horsepower based on SAE standard J1349.

156.3 to 158.2

156.3. Construction. Perform bulldozer work on the areas as specified on the plans, utilizing equipment as specified above. Where plans designate “Bulldozer Work” and “Blading,” or “Road Grader Work,” within the same limits, rough in with bulldozer work. Finish in accordance with specifications for “Blading” or “Road Grader Work.” Compact embankment to ordinary compaction in accordance with Item 132, “Embankment,” unless otherwise shown on the plans.

156.4. Measurement. This Item will be measured by the actual number of hours of use of the specified type of equipment operated.

156.5. Payment. The work performed in accordance with this Item and measured as provided under “Measurement” will be paid for at the unit price bid for “Bulldozer Work.” This price is full compensation for furnishing and operating equipment, labor, materials, tools, and incidentals. “Sprinkling” and “Rolling” will not be paid for directly, but will be subsidiary to this Item. Work performed under this Item will not include work specified for payment under other Items.

ITEM 158

SPECIALIZED EXCAVATION WORK

158.1. Description. Excavate, remove, use, or dispose of materials for erosion control or other specialized needs. Construct, shape, and rough-in earthwork in conformance with the required lines, grades, and typical sections as shown on the plans, or as directed.

158.2. Equipment. Unless otherwise approved, use equipment of the type specified on the plans. Use equipment that is able to consistently and efficiently produce the desired results.

- A. Dragline.** Self-propelled dragline with a minimum 1/2-cu.-yd. bucket.
- B. Backhoe.** Tractor mounted backhoe capable of excavating a trench at least 12 in. wide in one pass.
- C. Hydraulic Excavator.** Hydraulic excavator with a retractable, telescoping, rotatable boom attached to an interchangeable excavating or grading bucket at least 36 in. wide. The entire excavating mechanism must be mounted on a platform that rotates on a turntable assembly.
- D. Front-End Loader.** Tractor-mounted front-end loader with a minimum bucket capacity of 1-1/4 cu. yd.

158.3. Construction. Perform “Specialized Excavation Work” on the areas shown on the plans or as directed. Use suitable excavated materials, including topsoil, for constructing the required roadway sections. Compact material placed in embankment to ordinary compaction in accordance with Article 132.3, “Construction,” unless otherwise shown on the plans. Accept ownership of all excavated material unless otherwise shown on the plans. Stockpile materials designated salvageable at designated sites. Properly dispose of excess excavated material in accordance with local, state, and federal requirements at locations outside the right of way.

158.4. Measurement. This Item will be measured by the hour of work performed for specified equipment or by the cubic yard. Measurement by the cubic yard will be further defined as follows:

- A. Original.** The cubic yard will be measured in its original position as computed by the method of average end areas.
- B. Vehicle.** The cubic yard will be measured in vehicles at the point of excavation.

158.5. Payment. The work performed in accordance with this Item and measured by the hour as provided under “Measurement” will be paid for at the unit price bid for “Specialized Excavation Work” of the equipment type specified or, for cubic yard measurement, payment will be made at the unit price bid for “Specialized Excavation Work (Original),” or “Specialized Excavation Work (Vehicle).” This price is full compensation for hauling and disposing or stockpiling of excess materials and for equipment, labor, materials, tools, and incidentals. “Sprinkling” and “Rolling” will not be paid for directly, but will be subsidiary to this Item.

ITEM 160

TOPSOIL

160.1. Description. Furnish and place topsoil to the depths and on the areas shown on the plans.

160.2. Materials. Use easily cultivated, fertile topsoil that is free from objectionable material, has a high resistance to erosion, and is able to support plant growth. Obtain topsoil from the right of way at sites of proposed excavation or embankment when specified on the plans, or as directed. Secure additional topsoil, if necessary, from approved sources outside the right of way in accordance with the requirements of Article 7.19, “Preservation of Cultural and Natural Resources and the

160.2 to 160.5

Environment.” Ensure that the topsoil obtained from sites outside the right of way has a pH of 5.5 to 8.5. Topsoil is subject to testing by the Engineer. Use water that is clean and free of industrial wastes and other substances harmful to the growth of vegetation.

160.3. Construction. Remove and dispose of objectionable material from the topsoil source before beginning the work. Stockpile topsoil, when necessary, in a windrow at designated locations along the right of way line or as directed. Keep source and stockpile areas drained during the period of topsoil removal and leave them in a neat condition when removal is complete. Before placing topsoil, cultivate the area to a depth of 4 in. Spread the topsoil to a uniform loose cover at the thickness specified. Place and shape the topsoil as directed. Water and roll the topsoil with a light roller or other suitable equipment.

160.4. Measurement. This Item will be measured by the 100-ft. station along the baseline of each roadbed, by the square yard complete in place, or by the cubic yard in vehicles at the point of delivery.

160.5. Payment. The work performed and the materials furnished in accordance with this Item and measured as provided under “Measurement” will be paid for at the unit price bid for “Furnishing and Placing Topsoil” of the depth specified on the plans (except for measurement by the cubic yard). This price is full compensation for securing necessary sources and royalties; furnishing topsoil; excavation, loading, hauling, stockpiling and placing; watering; rolling; and equipment, labor, materials, tools, and incidentals. Limits of excavation and embankment for payment are shown in Figure 1.

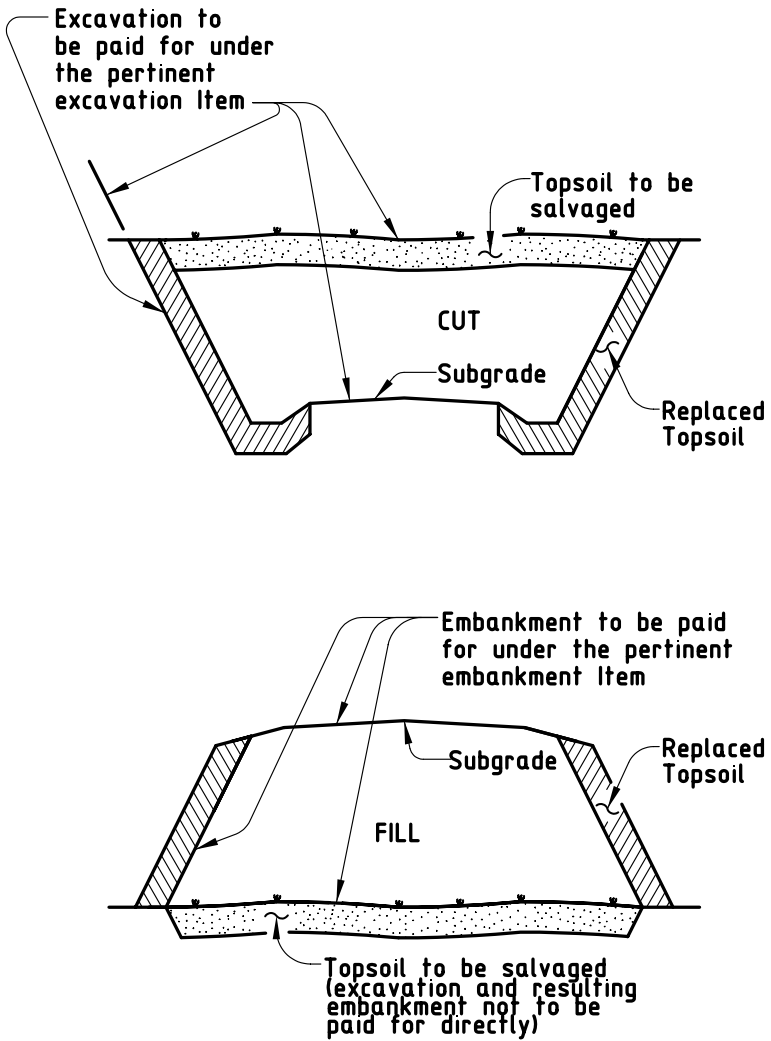

Figure 1
Roadway cross sections showing payment for excavation and embankment.

161.1 to 161.2

ITEM 161 COMPOST

161.1. Description. Furnish and place compost as shown on the plans.

161.2. Materials. Furnish compost that has been produced by aerobic (biological) decomposition of organic matter and meets the requirements of Table 1. Compost feedstock may include, but is not limited to, leaves and yard trimmings, biosolids, food scraps, food-processing residuals, manure or other agricultural residuals, forest residues, bark, and paper. Ensure compost and wood chips do not contain any visible refuse, other physical contaminants, or any substance considered harmful to plant growth. Do not use materials that have been treated with chemical preservatives as a compost feedstock or as wood chips. Do not use mixed municipal solid waste compost. Provide compost meeting all applicable 40 CFR 503 standards for Class A biosolids and TCEQ health and safety regulations as defined in the TAC, Chapter 332, including the time and temperature standards in Subchapter B, Part 23. Meet the requirements of the United States Composting Council (USCC) Seal of Testing Assurance (STA) program.

Before delivery of the compost, provide quality control (QC) documentation that includes the following:

- the feedstock by percentage in the final compost product,
- a statement that the compost meets federal and state health and safety regulations,
- a statement that the composting process has met time and temperature requirements,
- a copy of the producer's STA certification, and
- a copy of the lab analysis, performed by an STA-certified lab, verifying that the compost meets the requirements of Table 1.

When furnishing biosolids compost, also provide a copy of the current TCEQ compliance statement signed by the facility manager.

Table 1
Physical Requirements for Compost

Property	Test Method	Requirement
Particle Size	TMECC ¹ 02.02-B, “Sample Sieving for Aggregate Size Classification”	95% passing 5/8 in. 70% passing 3/8 in.
Heavy Metals Content	TMECC 04.06, “Heavy Metals and Hazardous Elements”: 04.06-As, Arsenic 04.06-Cd, Cadmium 04.06-Cu, Copper 04.06-Pb, Lead 04.06-Hg, Mercury 04.06-Mo, Molybdenum 04.06-Ni, Nickel 04.06-Se, Selenium 04.06-Zn, Zinc	Pass
Soluble Salts	TMECC 04.10-A, “1:5 Slurry Method, Mass Basis”	5.0 dS/m maximum ²
pH	TMECC 04.11-A, “1:5 Slurry pH”	5.5–8.5
Maturity	TMECC 05.05-A, “Germination and Root Elongation”	> 80%
Organic Matter Content	TMECC 05.07-A, “Loss-On-Ignition Organic Matter Method”	25–65% (dry mass)
Stability	TMECC 05.08-B, “Carbon Dioxide Evolution Rate”	8 or below
Fecal Coliform	TMECC 07.01-B, “Fecal Coliforms”	Pass

1. “Test Methods for the Examination of Composting and Compost,” published by the United States Department of Agriculture and the USCC.

2. A soluble salt content up to 10.0 dS/m for compost used in compost manufactured topsoil will be acceptable.

Provide a designated project stockpile of unblended compost for sampling and testing at the producer’s site. The Department will take samples from each stockpile for quality assurance (QA). Make payment to the STA-certified lab chosen by the Department for the required QA testing. Submit lab invoices for passing QA tests to the Department for reimbursement.

Maintain compost in designated stockpiles at the producer’s site until accepted by the Engineer. The Engineer reserves the right to sample compost at the jobsite.

161.3 to 161.3

- A. Compost Manufactured Topsoil (CMT).** CMT will consist of 75% topsoil blended with 25% compost measured by volume. Use CMT that is either blended on-site (BOS), blended in-place (BIP), or pre-blended (PB), as specified on the plans. Use topsoil conforming to Article 160.2, "Materials."
- B. Erosion Control Compost (ECC).** ECC will consist of 50% untreated wood chips blended with 50% compost measured by volume. Use wood chips less than or equal to 5 in. in length with 95% passing a 2-in. screen and less than 30% passing a 1-in. screen.
- C. General Use Compost (GUC).** GUC will consist of 100% compost.

161.3. Construction. Prepare the types of compost for use on the project and stockpile at the jobsite.

- A. Compost Manufactured Topsoil (CMT).** After excavation and embankment work is complete, remove and dispose of objectionable material from the topsoil before blending. Roll the CMT with a light corrugated drum.
 - 1. Blended On-Site (BOS).** Furnish topsoil. Topsoil may be salvaged from excavation and embankment areas, in accordance with Item 160, "Topsoil." Apply CMT to the depth shown on plans or apply compost in a uniform layer and incorporate into the in place topsoil to the depth shown on plans.
 - 2. Blended In-Place (BIP).** Apply compost in a uniform layer and incorporate into the existing in place topsoil to the depth shown on the plans.
 - 3. Pre-blended (PB).** Apply CMT in a uniform layer to the depth shown on the plans.
- B. Erosion Control Compost (ECC).** Use only on slopes 3:1 or flatter. After excavation and embankment work is complete, apply a 2-in. uniform layer, unless otherwise shown on the plans or as directed. When rolling is specified, use a light roller or other suitable equipment.
- C. General Use Compost (GUC).** Apply in a uniform layer as a top dressing on established vegetation to the depth shown on the plans. Do not bury existing vegetation. If using GUC as a backfill ingredient, in a planting soil mixture, for planting bed preparation, or as mulch, apply as shown on the plans.

161.4. Measurement. This Item will be measured by the 100-ft. station along the baseline of each roadbed, by the square yard complete in place, or by the cubic yard in vehicles at the point of delivery.

For CMT (BOS and PB only) and ECC cubic yard measurement, the quantity will be the composite material, compost and topsoil or wood chips.

161.5. Payment. The work performed and materials furnished in accordance with this Item and measured as provided under “Measurement” will be paid for at the unit price bid for “Compost Manufactured Topsoil (BOS),” “Compost Manufactured Topsoil (BIP),” “Compost Manufactured Topsoil (PB),” “Compost Manufactured Topsoil (BOS or PB),” “Erosion Control Compost,” and “General Use Compost” for the depth specified, except for measurement by the cubic yard. This price is full compensation for loading, hauling, stockpiling, blending, placing, rolling, sprinkling, equipment, labor, materials (including topsoil for CMT (BOS and PB only) and wood chips for ECC), tools, and incidentals. Costs associated with passing QA testing will be paid for in accordance with the requirements of Article 9.5, “Force Account,” at invoice price with no add-ons.

ITEM 162

SODDING FOR EROSION CONTROL

162.1. Description. Provide and install grass sod as shown on the plans or as directed.

162.2. Materials. Use live, growing grass sod of the type specified on the plans. Use grass sod with a healthy root system and dense matted roots throughout the soil of the sod for a minimum thickness of 1 in. Do not use sod from areas where the grass is thinned out. Keep sod material moist from the time it is dug until it is planted. Grass sod with dried roots is unacceptable.

- A. Block Sod.** Use block sod free from noxious weeds, Johnson grass, other grasses, or any matter deleterious to the growth and subsistence of the sod.
- B. Mulch Sod.** Use mulch sod from an approved source, free from noxious weeds, Johnson grass, other grasses, or any matter deleterious to the growth and subsistence of the sod.
- C. Fertilizer.** Furnish fertilizer in accordance with Article 166.2, “Materials.”

162.3 to 162.3

- D. Water.** Furnish water in accordance with Article 168.2, “Materials.”
- E. Mulch.** Use straw mulch consisting of oat, wheat or rice straw or hay mulch of either Bermudagrass or prairie grasses. Use straw or hay mulch free of Johnson grass and other noxious and foreign materials. Keep the mulch dry and do not use molded or rotted material.
- F. Tacking Methods.** Use a tacking agent applied in accordance with the manufacturer’s recommendations or a crimping method on all straw or hay mulch operations. Tacking agents must be approved before use, or may be specified on the plans.

162.3. Construction. Cultivate the area to a depth of 4 in. before placing the sod. Plant the sod specified and mulch, if required, after the area has been completed to lines and grades as shown on the plans. Apply fertilizer uniformly over the entire area in accordance with Article 166.3, “Construction,” and water in accordance with Article 168.3, “Construction.” Plant between the average date of the last freeze in the spring and 6 weeks prior to the average date for the first freeze in the fall according to the Texas Almanac for the project area.

A. Sodding Types.

- 1. Spot Sodding.** Use only Bermudagrass sod. Create furrows parallel to the roadway, approximately 5 in. deep and on 18-inch centers. Sod a continuous row not less than 3 in. wide in the 2 furrows adjacent to the roadway. Place 3-inch squares of sod on 15-inch centers in the remaining furrows. Place sod so that the root system will be completely covered by the soil. Firm all sides of the sod with the soil without covering the sod with soil.
- 2. Block Sodding.** Place sod blocks over the prepared area. Roll or tamp the sodded area to form a thoroughly compacted, solid mat filling all voids in the sodded area with additional sod. Keep sod along edges of curbs, driveways, walkways, etc., trimmed until acceptance.
- 3. Mulch Sodding.** Mow sod to no shorter than 4 in., and rake and remove cuttings. Disk the sod source in 2 directions, cutting the sod to a minimum of 4 in. Excavate the sod material to a depth of no more than 6 in. Keep excavated material moist or it will be rejected. Distribute the mulch sod uniformly over the area to a depth of 6 in. loose, unless otherwise shown on the plans, and roll with a light roller or other suitable equipment.

Add or reshape the mulch sod to meet the requirements of Section 162.3.B, "Finishing."

- B. Finishing.** Smooth and shape the area after planting to conform to the desired cross sections. Spread any excess soil uniformly over adjacent areas or dispose of the excess soil as directed.
- C. Straw or Hay Mulch.** Apply straw or hay mulch for "Spot Sodding" and "Mulch Sodding" uniformly over the area as shown on the plans. Apply straw mulch at 2 to 2-1/2 tons per acre. Apply hay mulch at 1-1/2 to 2 tons per acre. Use a tacking method over the mulched area.

162.4. Measurement. "Spot Sodding," "Block Sodding," and "Straw or Hay Mulch" will be measured by the square yard in its final position. "Mulch Sodding" will be measured by the square yard in its final position or by the cubic yard in vehicles as delivered to the planting site.

162.5. Payment. The work performed and materials furnished in accordance with this Item and measured as provided under "Measurement" will be paid for at the unit price bid for "Spot Sodding," "Block Sodding," "Straw or Hay Mulch," or "Mulch Sodding." This price is full compensation for securing a source, excavation, loading, hauling, placing, rolling, finishing, furnishing materials, equipment, labor, tools, supplies, and incidentals. Fertilizer will not be paid for directly but will be subsidiary to this Item.

Unless otherwise specified on the plans, water, except for that used for maintaining and preparing the sod before planting, will be measured and paid for in accordance with Item 168, "Vegetative Watering."

ITEM 164

SEEDING FOR EROSION CONTROL

164.1. Description. Provide and install temporary or permanent seeding for erosion control as shown on the plans or as directed.

164.2. Materials.

- A. Seed.** Provide seed from the previous season's crop meeting the requirements of the Texas Seed Law, including the testing and labeling for pure live seed (PLS = Purity x Germination). Furnish seed of the designated species, in labeled unopened bags or containers to the Engineer before planting. Use within 12 mo. From the date of the

164.2 to 164.2

analysis. When Buffalograss is specified, use seed that is treated with KNO_3 (potassium nitrate) to overcome dormancy.

Use Tables 1 through 4 to determine the appropriate seed mix and rates as specified on the plans.

Table 1
Permanent Rural Seed Mix

District and Planting Dates	Clay Soils		Sandy Soils	
	Species and Rates (lb. PLS/ac.)		Species and Rates (lb. PLS/ac.)	
1 (Paris) Feb. 1 – May 15	Green Sprangletop	0.3	Green Sprangletop	0.3
	Sideoats Grama (Haskell)	3.2	Bermudagrass	1.5
	Bermudagrass	1.8	Bahiagrass (Pensacola)	6.0
	Little Bluestem (Native)	1.7	Sand Lovegrass	0.6
	Illinois Bundleflower	1.0	Weeping Lovegrass (Ermelo)	0.8
			Partridge Pea	1.0
2 (Ft. Worth) Feb. 1 – May 15	Green Sprangletop	0.3	Green Sprangletop	0.3
	Sideoats Grama (El Reno)	2.7	Sand Lovegrass	0.5
	Bermudagrass	0.9	Bermudagrass	1.8
	Little Bluestem (Native)	1.0	Weeping Lovegrass (Ermelo)	0.8
	Blue Grama (Hachita)	0.9	Sand Dropseed	0.4
	Illinois Bundleflower	1.0	Partridge Pearl	1.0
3 (Wichita Falls) Feb. 1 – May 15	Green Sprangletop	0.3	Green Sprangletop	0.3
	Sideoats Grama (El Reno)	2.7	Bermudagrass	1.2
	Bermudagrass	0.9	Sand Dropseed	0.4
	Buffalograss (Texoka)	1.6	Sand Bluestem	2.4
	Western Wheatgrass	2.1	Sand Lovegrass	0.3
	Blue Grama (Hachita)	0.6	Weeping Lovegrass (Ermelo)	0.6
	Illinois Bundleflower	1.0	Purple Prairieclover	0.5
4 (Amarillo) Feb. 15 – May 15	Green Sprangletop	0.3	Green Sprangletop	0.3
	Sideoats Grama (El Reno)	3.6	Weeping Lovegrass (Ermelo)	0.8
	Blue Grama (Hachita)	1.2	Blue Grama (Hachita)	1.0
	Buffalograss (Texoka)	1.6	Sand Dropseed	0.3
	Illinois Bundleflower	1.0	Sand Bluestem	1.8
			Purple Prairieclover	0.5
5 (Lubbock) Feb. 15 – May 15	Green Sprangletop	0.3	Green Sprangletop	0.3
	Sideoats Grama (El Reno)	3.6	Weeping Lovegrass (Ermelo)	0.8
	Blue Grama (Hachita)	1.2	Blue Grama (Hachita)	1.0
	Buffalograss (Texoka)	1.6	Sand Dropseed	0.3
	Illinois Bundleflower	1.0	Sand Bluestem	1.8
			Purple Prairieclover	0.5

Table 1 (continued)
Permanent Rural Seed Mix

District and Planting Dates	Clay Soils		Sandy Soils	
	Species and Rates (lb. PLS/ac.)		Species and Rates (lb. PLS/ac.)	
6 (Odessa) Feb. 1 – May 15	Green Sprangletop	0.3	Green Sprangletop	0.3
	Sideoats Grama (Haskell)	2.3	Blue Grama	0.8
	Blue Grama (Hachita)	0.8	Sand Dropseed	0.4
	Alkali Sacaton	0.4	Weeping Lovegrass (Ermelo)	0.6
	Galleta	2.1	Indian Ricegrass	3.0
	Illinois Bundleflower	1.0	Purple Prairieclover	0.5
7 (San Angelo) Feb. 1 – May 1	Green Sprangletop	0.3	Green Sprangletop	0.3
	Sideoats Grama (Haskell)	2.7	Sideoats Grama (Haskell)	2.7
	Buffalograss (Texoka)	1.6	Weeping Lovegrass (Ermelo)	0.6
	Little Bluestem (Native)	1.7	Sand Dropseed	0.4
	Blue Grama (Hachita)	0.9	Purple Prairieclover	0.5
	Galleta	1.6		
	Illinois Bundleflower	1.0		
8 (Abilene) Feb. 1 – May 15	Green Sprangletop	0.3	Green Sprangletop	0.3
	Sideoats Grama (Haskell)	2.7	Sand Bluestem	3.0
	Blue Grama (Hachita)	0.9	Weeping Lovegrass (Ermelo)	1.2
	Galleta	1.6	Sand Dropseed	0.5
	Buffalograss (Texoka)	1.6	Purple Prairieclover	0.5
	Little Bluestem (Native)	1.7		
	Illinois Bundleflower	1.0		
9 (Waco) Feb. 1 – May 15	Green Sprangletop	0.3	Green Sprangletop	0.3
	Bermudagrass	1.2	Bermudagrass	2.4
	Sideoats Grama (Haskell)	3.6	Sand Dropseed	0.5
	Little Bluestem (Native)	2.0	Weeping Lovegrass (Ermelo)	0.8
	Illinois Bundleflower	1.0	Partridge Pea	1.0
10 (Tyler) Feb. 1 – May 15	Green Sprangletop	0.3	Green Sprangletop	0.3
	Bermudagrass	1.8	Bermudagrass	1.8
	Bahiagrass (Pensacola)	9.0	Bahiagrass (Pensacola)	9.0
	Sideoats Grama (Haskell)	2.7	Weeping Lovegrass (Ermelo)	0.5
	Illinois Bundleflower	1.0	Sand Lovegrass	0.5
			Lance-Leaf Coreopsis	1.0

Table 1 (continued)
Permanent Rural Seed Mix

District and Planting Dates	Clay Soils		Sandy Soils	
	Species and Rates (lb. PLS/ac.)		Species and Rates (lb. PLS/ac.)	
11 (Lufkin) Feb. 1 – May 15	Green Sprangletop	0.3	Green Sprangletop	0.3
	Bermudagrass	1.8	Bermudagrass	2.1
	Bahiagrass (Pensacola)	9.0	Bahiagrass (Pensacola)	9.0
	Sideoats Grama (Haskell)	2.7	Sand Lovegrass	0.5
	Illinois Bundleflower	1.0	Lance-Leaf Coreopsis	1.0
12 (Houston) Jan. 15 – May 15	Green Sprangletop	0.3	Green Sprangletop	0.3
	Bermudagrass	2.1	Bermudagrass	2.4
	Sideoats Grama (Haskell)	3.2	Bahiagrass (Pensacola)	10.5
	Little Bluestem (Native)	1.4	Weeping Lovegrass (Ermelo)	0.5
	Illinois Bundleflower	1.0	Lance-Leaf Coreopsis	1.0
13 (Yoakum) Jan. 15 – May 15	Green Sprangletop	0.3	Green Sprangletop	0.3
	Sideoats Grama (Haskell)	3.6	Bermudagrass	1.8
	Bermudagrass	1.8	Bahiagrass (Pensacola)	6.0
	Little Bluestem (Native)	1.4	Sand Lovegrass	0.6
	Illinois Bundleflower	1.0	Weeping Lovegrass (Ermelo)	0.6
			Partridge Pea	1.0
14 (Austin) Feb. 1 – May 15	Green Sprangletop	0.3	Green Sprangletop	0.3
	Bermudagrass	0.9	Bermudagrass	2.4
	Sideoats Grama (Haskell)	2.7	Weeping Lovegrass (Ermelo)	0.8
	Little Bluestem (Native)	1.0	Sand Lovegrass	0.8
	Blue Grama (Hachita)	0.9	Partridge Pea	1.0
	Illinois Bundleflower	1.0		
15 (San Antonio) Feb. 1 – May 1	Green Sprangletop	0.3	Green Sprangletop	0.3
	Bermudagrass	1.2	Bermudagrass	1.8
	Sideoats Grama (Haskell)	2.7	Lehmans Lovegrass	0.6
	Little Bluestem (Native)	1.4	Sand Lovegrass	0.6
	Plains Bristlegrass	1.2	Buffelgrass (Common)	0.4
	Illinois Bundleflower	1.0	Partridge Pea	1.0
16 (Corpus Christi) Jan. 1 – May 1	Green Sprangletop	0.3	Green Sprangletop	0.3
	Sideoats Grama (Haskell)	2.7	Bermudagrass	1.8
	Bermudagrass	1.8	Buffelgrass (Common)	0.4
	Buffalograss (Texoka)	1.6	Sand Lovegrass	0.6
	Plains Bristlegrass	1.2	Lehmans Lovegrass	0.6
	Illinois Bundleflower	1.0	Purple Prairieclover	0.5

Table 1 (continued)
Permanent Rural Seed Mix

District and Planting Dates	Clay Soils		Sandy Soils	
	Species and Rates (lb. PLS/ac.)		Species and Rates (lb. PLS/ac.)	
17 (Bryan) Feb. 1 – May 15	Green Sprangletop	0.3	Green Sprangletop	0.3
	Bermudagrass	1.5	Bermudagrass	1.5
	Sideoats Grama (Haskell)	3.6	Bahiagrass (Pensacola)	7.5
	Little Bluestem (Native)	1.7	Weeping Lovegrass (Ermelo)	0.6
	Illinois Bundleflower	1.0	Sand Lovegrass	0.6
			Lance-Leaf Coreopsis	1.0
18 (Dallas) Feb. 1 – May 15	Green Sprangletop	0.3	Green Sprangletop	0.3
	Bermudagrass	1.2	Bermudagrass	1.8
	Sideoats Grama (El Reno)	2.7	Weeping Lovegrass (Ermelo)	0.6
	Little Bluestem (Native)	2.0	Sand Lovegrass	0.6
	Buffalograss (Texoka)	1.6	Sand Dropseed	0.4
	Illinois Bundleflower	1.0	Partridge Pea	1.0
19 (Atlanta) Feb. 1 – May 15	Green Sprangletop	0.3	Green Sprangletop	0.3
	Bermudagrass	2.4	Bermudagrass	2.1
	Sideoats Grama (Haskell)	4.5	Bahiagrass (Pensacola)	7.5
	Illinois Bundleflower	1.0	Sand Lovegrass	0.6
			Lance-Leaf Coreopsis	1.0
20 (Beaumont) Jan. 15 – May 15	Green Sprangletop	0.3	Green Sprangletop	0.3
	Bermudagrass	2.7	Bermudagrass	2.1
	Sideoats Grama (Haskell)	4.1	Bahiagrass (Pensacola)	7.5
	Illinois Bundleflower	1.0	Sand Lovegrass	0.6
			Lance-Leaf Coreopsis	1.0
21 (Pharr) Jan. 15 – May 15	Green Sprangletop	0.3	Green Sprangletop	0.3
	Sideoats Grama (Haskell)	3.6	Bermudagrass	1.8
	Plains Bristlegrass	1.2	Buffelgrass (Common)	0.4
	Buffalograss (Texoka)	1.6	Sand Dropseed	0.4
	Bermudagrass	1.2	Lehmans Lovegrass	0.6
	Illinois Bundleflower	1.0	Purple Prairieclover	0.5
22 (Laredo) Jan. 15 – May 1	Green Sprangletop	0.3	Green Sprangletop	0.3
	Sideoats Grama (Haskell)	3.6	Bermudagrass	1.8
	Bermudagrass	1.2	Buffelgrass (Common)	0.4
	Buffalograss (Texoka)	1.6	Sand Dropseed	0.4
	Plains Bristlegrass	1.2	Lehmans Lovegrass	0.6
	Illinois Bundleflower	1.0	Purple Prairieclover	0.5

Table 1 (continued)
Permanent Rural Seed Mix

District and Planting Dates	Clay Soils		Sandy Soils	
	Species and Rates (lb. PLS/ac.)		Species and Rates (lb. PLS/ac.)	
23 (Brownwood) Feb. 1 – May 15	Green Sprangletop	0.3	Green Sprangletop	0.3
	Sideoats Grama (Haskell)	2.7	Bermudagrass	1.8
	Bermudagrass	0.6	Weeping Lovegrass (Ermelo)	0.6
	Blue Grama (Hachita)	0.9	Sand Lovegrass	0.6
	Galleta	2.1	Sand Dropseed	0.4
	Illinois Bundleflower	1.0	Purple Prairieclover	0.5
24 (El Paso) Feb. 1 – May 15	Green Sprangletop	0.3	Green Sprangletop	0.3
	Sideoats Grama (Butte)	2.7	Sand Dropseed	0.4
	Blue Grama (Hachita)	0.9	Lehmans Lovegrass	0.9
	Galleta	2.1	Blue Grama (Hachita)	1.0
	Alkali Sacaton	0.4	Indian Ricegrass	1.6
	Illinois Bundleflower	1.0	Purple Prairieclover	0.5
25 (Childress) Feb. 1 – May 15	Green Sprangletop	0.3	Green Sprangletop	0.3
	Sideoats Grama (El Reno)	2.7	Weeping Lovegrass (Ermelo)	1.2
	Blue Grama (Hachita)	0.9	Sand Dropseed	0.5
	Western Wheatgrass	2.1	Sand Lovegrass	0.8
	Galleta	1.6	Purple Prairieclover	0.5
	Illinois Bundleflower	1.0		

Table 2
Permanent Urban Seed Mix

District and Planting Dates	Clay Soils Species and Rates (lb. PLS/ac.)	Sandy Soils Species and Rates (lb. PLS/ac.)
1 (Paris) Feb. 1 – May 15	Green Sprangletop 0.3 Bermudagrass 2.4 Sideoats Grama (Haskell) 4.5	Green Sprangletop 0.3 Bermudagrass 5.4
2 (Ft. Worth) Feb. 1 – May 15	Green Sprangletop 0.3 Sideoats Grama (El Reno) 3.6 Bermudagrass 2.4 Buffalograss (Texoka) 1.6	Green Sprangletop 0.3 Sideoats Grama (El Reno) 3.6 Bermudagrass 2.1 Sand Dropseed 0.3
3 (Wichita Falls) Feb. 1 – May 15	Green Sprangletop 0.3 Sideoats Grama (El Reno) 4.5 Bermudagrass 1.8 Buffalograss (Texoka) 1.6	Green Sprangletop 0.3 Sideoats Grama (El Reno) 3.6 Bermudagrass 1.8 Sand Dropseed 0.4
4 (Amarillo) Feb. 15 – May 15	Green Sprangletop 0.3 Sideoats Grama (El Reno) 3.6 Blue Grama (Hachita) 1.2 Buffalograss (Texoka) 1.6	Green Sprangletop 0.3 Sideoats Grama (El Reno) 2.7 Blue Grama (Hachita) 0.9 Sand Dropseed 0.4 Buffalograss (Texoka) 1.6
5 (Lubbock) Feb. 15 – May 15	Green Sprangletop 0.3 Sideoats Grama (El Reno) 3.6 Blue Grama (Hachita) 1.2 Buffalograss (Texoka) 1.6	Green Sprangletop 0.3 Sideoats Grama (El Reno) 2.7 Blue Grama (Hachita) 0.9 Sand Dropseed 0.4 Buffalograss (Texoka) 1.6
6 (Odessa) Feb. 1 – May 15	Green Sprangletop 0.3 Sideoats Grama (Haskell) 3.6 Blue Grama (Hachita) 1.2 Buffalograss (Texoka) 1.6	Green Sprangletop 0.3 Sideoats Grama (Haskell) 2.7 Sand Dropseed 0.4 Blue Grama (Hachita) 0.9 Buffalograss (Texoka) 1.6
7 (San Angelo) Feb. 1 – May 1	Green Sprangletop 0.3 Sideoats Grama (Haskell) 7.2 Buffalograss (Texoka) 1.6	Green Sprangletop 0.3 Sideoats Grama (Haskell) 3.2 Sand Dropseed 0.3 Blue Grama (Hachita) 0.9 Buffalograss (Texoka) 1.6

Table 2 (continued)
Permanent Urban Seed Mix

District and Planting Dates	Clay Soils Species and Rates (lb. PLS/ac.)	Sandy Soils Species and Rates (lb. PLS/ac.)
8 (Abilene) Feb. 1 – May 15	Green Sprangletop 0.3 Sideoats Grama (Haskell) 3.6 Blue Grama (Hachita) 1.2 Buffalograss (Texoka) 1.6	Green Sprangletop 0.3 Sand Dropseed 0.3 Sideoats Grama (Haskell) 3.6 Blue Grama (Hachita) 0.8 Buffalograss (Texoka) 1.6
9 (Waco) Feb. 1 – May 15	Green Sprangletop 0.3 Bermudagrass 1.8 Buffalograss (Texoka) 1.6 Sideoats Grama (Haskell) 4.5	Green Sprangletop 0.3 Buffalograss (Texoka) 1.6 Bermudagrass 3.6 Sand Dropseed 0.4
10 (Tyler) Feb. 1 – May 15	Green Sprangletop 0.3 Bermudagrass 2.4 Sideoats Grama (Haskell) 4.5	Green Sprangletop 0.3 Bermudagrass 5.4
11 (Lufkin) Feb. 1 – May 15	Green Sprangletop 0.3 Bermudagrass 2.4 Sideoats Grama (Haskell) 4.5	Green Sprangletop 0.3 Bermudagrass 5.4
12 (Houston) Jan. 15 – May 15	Green Sprangletop 0.3 Sideoats Grama (Haskell) 4.5 Bermudagrass 2.4	Green Sprangletop 0.3 Bermudagrass 5.4
13 (Yoakum) Jan. 15 – May 15	Green Sprangletop 0.3 Sideoats Grama (Haskell) 4.5 Bermudagrass 2.4	Green Sprangletop 0.3 Bermudagrass 5.4
14 (Austin) Feb. 1 – May 15	Green Sprangletop 0.3 Bermudagrass 2.4 Sideoats Grama (Haskell) 3.6 Buffalograss (Texoka) 1.6	Green Sprangletop 0.3 Bermudagrass 4.8 Buffalograss (Texoka) 1.6
15 (San Antonio) Feb. 1 – May 1	Green Sprangletop 0.3 Sideoats Grama (Haskell) 3.6 Bermudagrass 2.4 Buffalograss (Texoka) 1.6	Green Sprangletop 0.3 Bermudagrass 4.8 Buffalograss (Texoka) 1.6
16 (Corpus Christi) Jan. 1 – May 1	Green Sprangletop 0.3 Sideoats Grama (Haskell) 3.6 Bermudagrass 2.4 Buffalograss (Texoka) 1.6	Green Sprangletop 0.3 Bermudagrass 4.8 Buffalograss (Texoka) 1.6

Table 2 (continued)
Permanent Urban Seed Mix

District and Planting Dates	Clay Soils Species and Rates (lb. PLS/ac.)	Sandy Soils Species and Rates (lb. PLS/ac.)
17 (Bryan) Feb. 1 – May 15	Green Sprangletop 0.3 Bermudagrass 2.4 Sideoats Grama (Haskell) 4.5	Green Sprangletop 0.3 Bermudagrass 5.4
18 (Dallas) Feb. 1 – May 15	Green Sprangletop 0.3 Sideoats Grama (El Reno) 3.6 Buffalograss (Texoka) 1.6 Bermudagrass 2.4	Green Sprangletop 0.3 Buffalograss (Texoka) 1.6 Bermudagrass 3.6 Sand Dropseed 0.4
19 (Atlanta) Feb. 1 – May 15	Green Sprangletop 0.3 Bermudagrass 2.4 Sideoats Grama (Haskell) 4.5	Green Sprangletop 0.3 Bermudagrass 5.4
20 (Beaumont) Jan. 15 – May 15	Green Sprangletop 0.3 Bermudagrass 2.4 Sideoats Grama (Haskell) 4.5	Green Sprangletop 0.3 Bermudagrass 5.4
21 (Pharr) Jan. 15 – May 15	Green Sprangletop 0.3 Sideoats Grama (Haskell) 3.6 Buffalograss (Texoka) 1.6 Bermudagrass 2.4	Green Sprangletop 0.3 Buffalograss (Texoka) 1.6 Bermudagrass 3.6 Sand Dropseed 0.4
22 (Laredo) Jan. 15 – May 1	Green Sprangletop 0.3 Sideoats Grama (Haskell) 4.5 Buffalograss (Texoka) 1.6 Bermudagrass 1.8	Green Sprangletop 0.3 Buffalograss (Texoka) 1.6 Bermudagrass 3.6 Sand Dropseed 0.4
23 (Brownwood) Feb. 1 – May 15	Green Sprangletop 0.3 Sideoats Grama (Haskell) 3.6 Bermudagrass 1.2 Blue Grama (Hachita) 0.9	Green Sprangletop 0.3 Buffalograss (Texoka) 1.6 Bermudagrass 3.6 Sand Dropseed 0.4
24 (El Paso) Feb. 1 – May 15	Green Sprangletop 0.3 Sideoats Grama (Butte) 3.6 Blue Grama (Hachita) 1.2 Buffalograss (Texoka) 1.6	Green Sprangletop 0.3 Buffalograss (Texoka) 1.6 Sand Dropseed 0.4 Blue Grama (Hachita) 1.8
25 (Childress) Feb. 1 – May 15	Green Sprangletop 0.3 Sideoats Grama (El Reno) 3.6 Blue Grama (Hachita) 1.2 Buffalograss (Texoka) 1.6	Green Sprangletop 0.3 Sand Dropseed 0.4 Buffalograss (Texoka) 1.6 Bermudagrass 1.8

Table 3
Temporary Cool Season Seeding

Districts	Dates	Seed Mix and Rates (lb./ac.)
Paris (1), Amarillo (4), Lubbock (5), Dallas (18)	September 1 – November 30	Tall Fescue 4.5 Western Wheatgrass 5.6 Wheat (Red, Winter) 34
Odessa (6), San Angelo (7), El Paso (24)	September 1 – November 30	Western Wheatgrass 8.4 Wheat (Red, Winter) 50
Waco (9), Tyler (10), Lufkin (11), Austin (14), San Antonio (15), Bryan (17), Atlanta (19)	September 1 – November 30	Tall Fescue 4.5 Oats 24 Wheat 34
Houston (12), Yoakum (13), Corpus Christi (16), Beaumont (20), Pharr (21), Laredo (22)	September 1 – November 30	Oats 72
Ft. Worth (2), Wichita Falls (3), Abilene (8), Brownwood (23), Childress (25)	September 1 – November 30	Tall Fescue 4.5 Western Wheatgrass 5.6 Cereal Rye 34

Table 4
Temporary Warm Season Seeding

Districts	Dates	Seed Mix and Rates (lb./ac.)
All	May 1 – August 31	Foxtail Millet 34

- B. Fertilizer.** Use fertilizer in conformance with Article 166.2, “Materials.”
- C. Vegetative Watering.** Use water that is clean and free of industrial wastes and other substances harmful to the growth of vegetation.
- D. Mulch.**
- 1. Straw or Hay Mulch.** Use straw or hay mulch in conformance with Article 162.2.E, “Mulch.”
 - 2. Cellulose Fiber Mulch.** Use only cellulose fiber mulches that are on the approved list published in “Field Performance of Erosion Control Products,” available from the Maintenance Division. Submit 1 full set of manufacturer’s literature for the selected material. Keep mulch dry until applied. Do not use molded or rotted material.
- E. Tacking Methods.** Use a tacking agent applied in accordance with the manufacturer’s recommendations or a crimping method on all straw or

164.3 to 164.3

hay mulch operations. Tacking agents must be approved before use, or specified on the plans.

164.3. Construction. Cultivate the area to a depth of 4 in. before placing the seed unless otherwise directed. When performing permanent seeding after an established temporary seeding, cultivate the seedbed to a depth of 4 in. or mow the area before placement of the permanent seed. Plant the seed specified and mulch, if required, after the area has been completed to lines and grades as shown on the plans.

- A. Broadcast Seeding.** Distribute the seed or seed mixture uniformly over the areas shown on the plans using hand or mechanical distribution or hydro-seeding on top of the soil. When seed and water are to be distributed as a slurry during hydro-seeding, apply the mixture to the area to be seeded within 30 min. of placement of components in the equipment. Roll the planted area with a light roller or other suitable equipment. Roll sloped areas along the contour of the slopes.
- B. Straw or Hay Mulch Seeding.** Plant seed according to Section 164.3.A, “Broadcast Seeding.” Immediately after planting the seed or seed mixture, apply straw or hay mulch uniformly over the seeded area. Apply straw mulch at 2 to 2.5 tons per acre. Apply hay mulch at 1.5 to 2 tons per acre. Use a tacking method over the mulched area.
- C. Cellulose Fiber Mulch Seeding.** Plant seed according to Section 164.3.A, “Broadcast Seeding.” Immediately after planting the seed or seed mixture, apply cellulose fiber mulch uniformly over the seeded area at the following rates:
- Sandy Soils with slopes of 3:1 or less—2500 lb. per acre.
 - Sandy Soils with slopes greater than 3:1—3000 lb. per acre.
 - Clay Soils with slopes of 3:1 or less—2000 lb. per acre.
 - Clay Soils with slopes greater than 3:1—2300 lb. per acre.
- Cellulose fiber mulch rates are based on dry weight of mulch per acre. Mix cellulose fiber mulch and water to make a slurry and apply uniformly over the seeded area using suitable equipment.
- D. Drill Seeding.** Plant seed or seed mixture uniformly over the area shown on the plans at a depth of 1/4 to 1/3 in. using a pasture or rangeland type drill. Plant seed along the contour of the slopes.
- E. Straw or Hay Mulching.** Apply straw or hay mulch uniformly over the area as indicated on the plans. Apply straw mulch at 2 to 2.5 tons per acre. Apply hay mulch at 1.5 to 2 tons per acre. Use a tacking method over the mulched area.

Apply fertilizer in conformance with Article 166.3, "Construction." Seed and fertilizer may be distributed simultaneously during "Broadcast Seeding" operations, provided each component is applied at the specified rate. When temporary and permanent seeding are both specified for the same area, apply half of the required fertilizer during the temporary seeding operation and the other half during the permanent seeding operation.

Water the seeded areas at the rates and frequencies as shown on the plans or as directed.

164.4. Measurement. This Item will be measured by the square yard or by the acre.

164.5. Payment. The work performed and the materials furnished in accordance with this Item and measured as provided under "Measurement" will be paid for at the unit price bid for "Broadcast Seeding (Perm)" of the rural or urban seed mixture and sandy or clay soil specified, "Broadcast Seeding (Temp)" of warm or cool season specified, "Straw or Hay Mulch Seeding (Perm)" of the rural or urban seed mixture and sandy or clay soil specified, "Straw or Hay Mulch Seeding (Temp)" of warm or cool season specified, "Cellulose Fiber Mulch Seeding (Perm)" of the rural or urban seed mixture and sandy or clay soil specified, "Cellulose Fiber Mulch Seeding (Temp)" of warm or cool season specified, "Drill Seeding (Perm)" of the rural or urban seed mixture and sandy or clay soil specified, "Drill Seeding (Temp)" of warm or cool season specified, and "Straw or Hay Mulching." This price is full compensation for furnishing materials, including water for hydro-seeding and hydro-mulching operations, mowing, labor, equipment, tools, supplies, and incidentals. Fertilizer will not be paid for directly but will be subsidiary to this Item. Water for irrigating the seeded area, when specified, will be paid for under Item 168, "Vegetative Watering."

ITEM 166 FERTILIZER

166.1. Description. Provide and distribute fertilizer over areas specified on the plans.

166.2. Materials. Use a complete fertilizer containing nitrogen (N), phosphoric acid (P), and potash (K) nutrients unless otherwise specified on the plans. At least 50% of the nitrogen component must be of a slow-release

166.2 to 168.3

formulation such as urea-based and plastic resin-coated fertilizers. Ensure that fertilizer is in an acceptable condition for distribution in containers labeled with the analysis. Fertilizer is subject to testing by the Texas A&M Feed and Fertilizer Control Service in accordance with the Texas Fertilizer Law.

166.3. Construction. Deliver and apply the complete fertilizer uniformly at a rate equal to 100 lb. of nitrogen per acre or at the analysis and rate specified on the plans.

166.4. Measurement. When fertilizer is specified on the plans to be a pay item, measurement will be by the acre of surface area covered or by the ton (2,000 lb.). Measurement by the ton will use guaranteed weight of bags or containers as shown by the manufacturer or certified scales meeting the requirements of Item 520, "Weighing and Measuring Equipment," unless otherwise approved.

166.5. Payment. Unless otherwise specified on the plans, the work performed, materials furnished, equipment, labor, tools, and incidentals will not be paid for directly but will be considered subsidiary to bid items of the Contract.

When fertilizer is specified on the plans to be a pay item, the work performed and materials furnished in accordance with this Item and measured as provided under "Measurement" will be paid for at the unit price bid for "Fertilizer." This price is full compensation for furnishing materials and performing operations.

ITEM 168

VEGETATIVE WATERING

168.1. Description. Provide and distribute water to promote growth of vegetation as directed.

168.2. Materials. Use water that is clean and free of industrial wastes and other substances harmful to the growth of vegetation.

168.3. Construction. Apply water when directed. Furnish and operate equipment to distribute water at a uniform and controllable rate. Ensure that watering does not erode soil or plantings. Apply water in the required quantity where shown on the plans or as directed.

168.4. Measurement. This Item will be measured by the 1000 gal. as applied.

168.5. Payment. The work performed and materials furnished in accordance with this Item and measured as provided under “Measurement” will be paid for at the unit price bid for “Vegetative Watering.” This price is full compensation for furnishing and operating watering equipment and measuring devices and for furnishing and applying water, including hauling, equipment, labor, and incidentals.

ITEM 169

SOIL RETENTION BLANKETS

169.1. Description. Provide and install soil retention blankets (SRB) as shown on the plans or as directed.

169.2. Materials. Provide only SRB that are on the approved list published in “Field Performance of Erosion Control Products,” available from the Maintenance Division. Use material of the following class and type as shown on the plans and provide a copy of the manufacturer’s label for the selected product.

A. Class 1 - Slope Protection.

1. **Type A.** Slopes 3:1 or flatter - clay soils,
2. **Type B.** Slopes 3:1 or flatter - sandy soils,
3. **Type C.** Slopes steeper than 3:1 - clay soils, and
4. **Type D.** Slopes steeper than 3:1 - sandy soils.

B. Class 2 - Flexible Channel Liners.

1. **Type E.** Biodegradable materials with shear stress less than 1.0 lb. per square foot,
2. **Type F.** Biodegradable materials with shear stress 1.0 to 2.0 lb. per square foot,
3. **Type G.** Nonbiodegradable materials with shear stress 2.0 to 5.0 lb. per square foot, and
4. **Type H.** Nonbiodegradable materials with shear stress equal to or greater than 5.0 lb. per square foot.

169.3. Construction. Place the SRB within 24 hr. after the seeding or sodding operations, or when directed, in accordance with the “SRB Product

169.3 to 170.2

Installation Sheet,” available from the Maintenance Division. Installation includes the repair of ruts, reseeding or resodding, and the removal of rocks, clods, and other foreign materials which may prevent contact of the blanket with the soil.

169.4. Measurement. This Item will be measured by the square yard of surface area covered.

169.5. Payment. The work performed and materials furnished in accordance with this Item and measured as provided under “Measurement” will be paid for at the unit price bid for “Soil Retention Blankets” of the class and type specified. This price is full compensation for equipment, materials, labor, tools, and incidentals.

ITEM 170

IRRIGATION SYSTEM

170.1. Description. Furnish and install an irrigation system as shown on the plans.

170.2. Materials. Unless otherwise shown on the plans, use materials that meet the following:

- A. Irrigation Pipe.** Use polyvinyl chloride (PVC) pipe meeting ASTM D 2241, SDR 13.5, SDR 17, SDR 21; or ASTM D 1785, Schedule 40.
- B. Fittings.** Furnish fittings as shown on the plans. PVC fittings must meet ASTM D 2466.
- C. Encasement Pipe.** Use PVC pipe meeting ASTM D 1785, Schedule 40, with an inside diameter at least 1 in. larger than the outside diameter of the irrigation pipe, unless otherwise shown on the plans.
- D. Low-Voltage Wire.** Use minimum 14 gauge UL-approved wire for direct burial.
- E. Bentonite Slurry.** Use a viscous mixture of commercial bentonite and fresh water containing 2% to 8% bentonite by weight.
- F. Accessories.** Use valves, sprinkler heads, and controllers that meet the requirements shown on the plans. Use backflow preventers that meet the requirements of the controlling water utility authority.

- G. Electrical Service.** For installations requiring over 100 volts, use materials meeting the requirements of Section 170.3.A, “Electrical Service.”

170.3. Construction. Perform irrigation system work under the supervision of a person possessing an irrigator’s license issued by the TCEQ. Provide documentation of this license. Perform electrical work in accordance with Article 8.9, “Workers and Equipment.” Follow the codes of the controlling utility authority for water and electrical connection and service.

Coordinate irrigation system installation with plant installation, when plant installation is specified, to ensure that watering requirements are met. Prevent damage to vegetation, slopes, utilities, structures, and other amenities. Repair any damage within the right of way caused by the Contractor. Perform the following activities as required:

- A. Electrical Service.** For installations requiring over 100 volts, construct in accordance with the details shown on the plans and the pertinent requirements of the following:
- Item 618, “Conduit”
 - Item 620, “Electrical Conductors”
 - Item 622, “Duct Cable”
 - Item 624, “Ground Boxes”
 - Item 628, “Electrical Services.”
- B. Excavation and Trenching.** Excavate and trench to a sufficient depth to provide for a minimum of 12 in. soil cover for all lines or as shown on the plans. Use common trenches for irrigation lines and wire runs where feasible. Protect trenches and boring pits less than 5 ft. deep using approved methods. Protect trenches and boring pits 5 ft. deep or deeper in accordance with Item 402, “Trench Excavation Protection,” and Item 403, “Temporary Special Shoring.”
- C. Boring.** Bore at the locations shown on the plans or as directed. Avoid weakening or damaging roadways or other facilities. Bore the lengths in one direction only. Maintain horizontal and vertical alignment to an accuracy of 1 in. in 10 ft. Use water or other approved fluids in connection with boring operations only to lubricate cuttings.
- In unconsolidated soil formations, bentonite slurry may be used to consolidate cuttings for the bit, seal the walls of the hole, and furnish lubrication for subsequent removal of cuttings and installation of the pipe immediately thereafter.
- D. Water Jetting.** Use water jetting only when shown on the plans or approved in writing by the Engineer. Water jet the lengths in one

170.3 to 170.3

direction only. When jetting operations fail to produce a smooth stable hole, cease operations and complete all necessary work by boring.

- E. Encasement.** Provide a minimum of 12 in. of cover over encasement pipe. Cover is measured to the top of the subgrade for paved areas and to the bottom of the slab for sidewalks or nonload-bearing slabs.
- F. Pipe and Valve Assembly.** Assemble pipe and fittings as recommended by the manufacturers. Clean pipe and fittings of dust, dirt, and moisture before assembly. Make connections between plastic pipe and metal valves with threaded fittings and plastic adapters. Install backflow preventers as required by ordinances of the controlling water utility authority. Install pipe, valves, and valve boxes a minimum of 12 in. from sidewalks, buildings, walls, and other objects, or as directed.
- G. Sprinkler Heads and Drip Tubing.** Install sprinkler heads and drip tubing in accordance with the manufacturer's recommendations at locations shown on the plans or as directed.
- H. Controller.** Install controllers in accordance with the manufacturer's recommendations at locations shown on the plans or as directed.
- I. Low-Voltage Wire.** Install wire in trenches below the pipe or in a minimum 1-in. PVC pipe with at least 12 in. of cover over its entire run. Install wire in continuous lengths. Splice wire, if required, in valve boxes using waterproof materials.
- J. Closing and Flushing of PVC Pipe.** Cap or plug pipe after installation to prevent entry of foreign materials that would obstruct the flow of water. Leave caps or plugs in place until removal is necessary for completion of the installation. Thoroughly flush all water lines.
- K. Hydrostatic Tests.** Notify the Engineer in writing at least 48 hr. before testing. Center load all pipe with sufficient backfill to prevent arching or slipping while under pressure. After all welded joints have cured for at least 24 hr., test the main lines from the meter to the valves, with all valves closed, for at least 2 consecutive hours by applying a continuous and static minimum 80-psi water pressure. Repair leaks if necessary and retest. Before final approval, maintain the lines under static pressure for 24 hr. without leaks.
- L. Backfill and Compaction.** After the irrigation system is fully operational, and all tests and inspections have been performed and the results approved, backfill trenches and other excavations with soil free of objectionable material. Backfill and compact in 8-in. layers. Smooth and shape disturbed soil to final grade or as directed.

170.4. Measurement. This Item will be measured by the lump sum.

170.5. Payment. The work performed and the materials furnished in accordance with this Item and measured as provided under “Measurement” will be paid for at the unit price bid for “Irrigation System.” This price is full compensation for furnishing and installing all components; flushing and testing water lines; furnishing and operating equipment; and labor, tools, and incidentals. Protection methods for excavations 5 ft. deep or deeper will be measured and paid for as required under Item 402, “Trench Excavation Protection,” or Item 403, “Temporary Special Shoring.” Electrical work required in accordance with Section 170.3.A, “Electrical Service,” will be measured and paid for under Item 628, “Electrical Services.” Power consumed will be paid for by the Department.

ITEM 180

WILDFLOWER SEEDING

180.1. Description. Prepare the surface and provide and sow wildflower seed as shown on the plans or as directed.

180.2. Materials. Provide seed of the previous season’s crop meeting the requirements of the Texas Seed Law, including the testing and labeling for pure live seed (PLS = purity x germination). Furnish seed of the designated species in unopened bags or containers to the Engineer before planting, with labels showing the date of the analysis to be not more than 12 mo. before the time of use.

180.3. Equipment. Use equipment shown on the plans or as directed that will evenly distribute the seed over the area.

180.4. Construction. Mow locations designated for wildflower planting to an approximate height of 4 in. Distribute the seed or seed mixture uniformly at the rates and locations shown on the plans or as directed.

180.5. Measurement. This Item will be measured by the acre.

180.6. Payment. The work performed in accordance with this Item and measured as provided under “Measurement” will be paid for at the unit price bid for “Wildflower Seeding.” This price is full compensation for seed, equipment, labor, tools, and incidentals.

192.1 to 192.2

ITEM 192 LANDSCAPE PLANTING

192.1. Description. Provide and install plants and related materials at designated locations. Maintain plants, related materials, and landscaped areas at the specified frequency.

192.2. Materials. Comply with the latest standards as follows, unless otherwise shown on the plans:

- “American Standard for Nursery Stock,” published by the American Association of Nurserymen, Inc.
 - “Standardized Plant Names,” published by the American Joint Committee on Horticultural Nomenclature.
 - Meet additional requirements for plants and related materials as shown on the plans.
- A. Plants.** Provide nursery-grown plants unless otherwise shown on the plans. Provide vigorous, healthy, well-rooted, plants with well-formed crowns, true to sizes, and of typical shape and characteristics of the species. Provide plants with nametags attached showing the genus, species, and specified variety.
- B. Rejection of Plants.** Plants with any of the following characteristics are subject to rejection:
- disease or insect infestation, including eggs and larvae;
 - dried or damaged root system or crown;
 - excessive abrasion of the bark;
 - prematurely opened or damaged buds;
 - disfiguring knots;
 - evidence of heat, freeze, or wind burn, mold, sun scald, or similar conditions;
 - damaged, pruned, crooked, or multiple leaders, unless multiple leaders are specified or are normal for the species;
 - cut limbs over 3/4 in. in diameter that have not completely callused;
 - dry, soggy, loose, cracked, broken, misshapen or undersized root balls;
 - processed balled roots (bench balled);
 - root balls encased in impervious material;
 - overgrown or root-bound plants;
 - undersized or unsound containers;
 - stock not well established in containers;
 - containers with less than 3/4 planting medium depth;

- an abnormal balance between height and spread for the species;
 - missing or broken serialized locking tags, when specified;
 - any condition that does not conform to the plans or nursery stock standards; or
 - conditions that would prevent thriving growth or cause an unacceptable appearance.
- C. Backfill and Plant Soil Mix.** Use soil excavated from the plant pits or beds or provide a loose, friable soil mix as shown on the plans. Provide a soil mix free of reproductive parts of weeds and grasses, harmful substances, and detrimental amounts of foreign matter. Use compost in accordance with Article 161.2.C, “General Use Compost,” when specified on the plans.
- D. Mulch.** Provide loose, organic mulch derived from plants unless other types are shown on the plans. Use mulch free of excessive amounts of leaves, sticks, harmful substances, and detrimental amounts of soil, or other foreign matter.
- E. Water.** Use water that is clean and free of industrial wastes and other substances harmful to the growth of vegetation.
- F. Fertilizer.** Use fertilizer conforming to Article 166.2, “Materials,” unless otherwise shown on the plans.
- G. Other Materials.** Provide additional incidental materials associated with landscape planting and meet the requirements shown on the plans.

192.3. Construction. Prevent damage to vegetation, slopes, utilities, structures, and other amenities. Repair any damage within the right of way caused by the Contractor at no additional expense to the Department. Provide and document a licensed pesticide applicator for the treatment of insects, diseases, animals, and vegetation in accordance with the TDA or the TSPCB in the appropriate use category.

- A. Plant Inspection Before Delivery.** Plants are subject to inspection at the nursery or location of collection. When directed, provide and use serialized locking tags on plants selected by the Engineer.
- B. Plant Delivery.** Notify the Engineer at least 48 hours before delivering plants to the worksite. Coordinate with the Engineer for inspection and approval of materials upon delivery. Remove rejected plants from the worksite and replace as directed.
- C. Mark Plant Locations and Bed Outlines.** Provide and install coded markings, such as wooden stakes, to mark the locations, type of plants,

192.3 to 192.3

and the outline of planting beds. Obtain approval of the plant and bed locations before excavation begins.

- D. Plant Pit Excavation.** Excavate pits for container, balled and burlapped (B&B), and fabric bag grown stock to the depth shown on the plans or at least the depth of the root ball. Excavate pits for bare root plants equal to the depth of the root system. Excavate pits on slopes using measurements shown on the plans or at least the depth of the root ball based on the uphill side of the pit. Excavate the receiving pits for mechanically transplanted plants with the same type and size equipment used to dig the plants.

Provide a minimum horizontal dimension of 12 in. between the root ball and pit walls for the following:

- 15-gal. or larger pots,
- 14-in. or larger boxes, and
- larger than 14-in. root balls of B&B and fabric bag grown plants.

Provide a minimum horizontal dimension of 2 times the root ball diameter across the pit for the following:

- less than 15-gal. pots, and
- 14-in. or smaller root balls of B&B and fabric bag grown plants.

Provide a minimum pit diameter for bare root plants that permits the roots to spread without crowding or curving around the walls of the pit.

- E. Plant Installation.** Install plants, within 24 hr. of excavating plant pits. Scarify the walls of pits as plant installation begins. For all plants, except those mechanically collected, center plant in pit and backfill in lifts, each lift 1/3 the depth of the root ball, and fill the pit with water after each lift to remove air pockets. For mechanically collected plants, prune protruding roots from the root ball to a point even with the cutting blades. Place the plant in the pit and work sand between the pit walls and the root ball with water until the sand fills all the cavities.

Apply fertilizer according to the plans. Ensure that the top of the root ball remains at the grade shown on the plans after final settlement.

- F. Plant Basin Construction.** Construct a basin at least 8 in. deep with an inside diameter equal to the pit diameter and with a level top around the plant unless otherwise shown on the plans. Use excavated soil from the plant pits or beds, backfill material, or other approved material for the basin. Spread excess excavated materials over the right of way as directed or remove and dispose of material in accordance with local, state, and federal requirements at locations outside the right of way.

- G. Watering.** Coordinate the planting work to ensure that an irrigation system, when specified, operates properly to meet the watering requirements. Apply water to plants or planting areas at the rate and frequency specified for an irrigation system or for the application method shown on the plans. Keep the ground and backfill moist at least 12 in. around the entire root ball if a watering rate and frequency are not specified.
- H. Using Antitranspirants.** Apply antitranspirants, when shown on the plans, in accordance with the manufacturer's instructions.
- I. Pruning.** Accomplish pruning in accordance with ANSI A300 pruning standards unless otherwise shown on the plans or directed. Retain the natural shape of plants according to the species. Limit pruning to removal of dead and broken branches, and an additional amount as specified or directed to improve the appearance and health of plants.
- For B&B and collected plants, prune to reduce the original crown by approximately 20% by removing interior branches, entangled limbs, and small branches unless otherwise shown on the plans. Prune to develop the central leader or leaders. Apply wound dressing on oak (*Quercus*) species within 20 min. of causing bark damage or making a pruning cut. Apply wound dressing on other plants when shown on the plans or directed. Use wound dressing in accordance with the pruning standards. Remove and dispose of pruning debris.
- J. Plant Support Installation.** Install plant supports such as staking, guying, and bracing as shown on the plans. Support and keep plants in a vertical position or as directed.
- K. Tree Trunk Protection.** Install tree trunk protection guards when shown on the plans in accordance with the manufacturer's instructions.
- L. Landscape Edge Installation.** Install landscape edging when shown on the plans and in accordance with the manufacturer's instructions.
- M. Plant Bed Preparation.** Prepare the bed and install the planting soil mix, vegetation barrier, and other materials as shown on the plans.
- N. Mulching.** Mulch plant basins and beds to a depth of 2 in. unless otherwise shown on the plans.
- O. Maintenance.** Begin maintenance under this Item when the installation of plants on the project is completed and approved, or as directed. Perform the maintenance work for a minimum of 90 calendar days at designated locations by following the work schedule and frequencies shown on the plans. If a work schedule and frequency are not shown on the plans, perform the minimum requirements stated below.

192.3 to 192.3

1. **Watering.** Water in accordance with Section 192.3.G, “Watering.”
2. **Mowing, Trimming, and Edging.** Mow, trim, and edge the designated locations. Mow, trim, and edge every 15 days during the growing season or as directed, mowing at a 3-4 in. height. Keep cord trimmers at least 1 ft. from plants to prevent damage to the plants. Plants damaged during the maintenance work are subject to rejection and replacement according to Section 192.3.O.9, “Plant Replacement.”
3. **Plant Basin, Bed, and Worksite Maintenance.** Chemically control weeds and unwanted grasses in plant basins, beds, along and in structures, and around existing plants every 15 days, unless otherwise directed. Reshape plant basins and beds every 30 days to conform to the plans. Maintain mulch in accordance with Section 192.3.N, “Mulching.” Ensure that herbicides do not contact desirable plants. Follow the manufacturer’s instruction for handling and applying herbicides.
4. **Plant Supports.** Replace, repair, and adjust supports to meet the requirements of the plans and in accordance with Section 192.3.J, “Plant Support Installation.” Adjust staking and guying to prevent girdling of plant trunks. Remove or dispose of support material, as directed.
5. **Pruning.** Prune as shown on the plans and in accordance with Section 192.3.I, “Pruning.”
6. **Insect, Disease, and Animal Inspection and Treatment.** Inspect plants and planted areas at least every 15 days. Notify the Engineer of concerns and problems and recommend corrective measures in writing for approval. Treat the plants and planted areas in accordance with TDA or TSPCB laws and regulations. Follow the manufacturer’s instructions for handling and applying pesticides.
7. **Litter and Debris Collection and Disposal.** Collect litter and debris within the worksite before mowing and trimming at least every 15 days. Dispose of litter and debris as directed.
8. **Tree Trunk Wrap and Protection Guard Removal and Disposal.** Remove and dispose of tree trunk wrapping material and protection guards as directed.
9. **Plant Replacement.** Remove and dispose of dead and damaged plants from the worksite as directed. Replace plants as originally specified within 10 days of notification. When notification is made between the starting date and day 30 of the maintenance work,

plant replacement must be completed and approved before payment is approved, according to Section 192.5.B, “30-Day Payment.” When notification is made between days 31 and 60 of the maintenance work, plant replacement must be completed and approved before payment is approved, according to Section 192.5.C, “60-Day Payment.” When notification is made between days 61 and 90 of the maintenance work, plant replacement must be completed and approved before payment is approved, according to Section 192.5.D, “Final Payment.”

192.4. Measurement. This Item will be measured by each plant. When mulch is specified as a separate pay item, it will be measured by the cubic yard or the square yard. When plant soil mix is specified as a separate pay item, it will be measured by the cubic yard. When landscape edge is specified as a separate pay item, it will be measured by the foot. When plant bed preparation is specified as a separate pay item, it will be measured by the square yard. When vegetation barrier is specified as a separate pay item, it will be measured by the square yard.

192.5. Payment. The work performed and materials furnished in accordance with this Item and measured as provided under “Measurement” will be paid for at the unit price bid for “Plant Material” of the size, “Plant Material” of the size and type specified or “Plant Material” of the group specified. This price is full compensation for furnishing the plant, mulch, plant soil mix, landscape edge, plant bed preparation and vegetation barrier, unless mulch, plant soil mix, landscape edge, plant bed preparation and vegetation barrier are specified as separate items. Payment for “Plant Material” will be handled in the following manner:

- A. Initial Payment.** When the planting and installation of related materials are completed and approved, 55% of the unit price bid for each plant will be paid.
- B. 30-Day Payment.** When the first 30 days of the 90-day maintenance (see Section 192.3.O, “Maintenance”) are completed and approved, an additional 15% of the total price bid for all plants will be paid, but if the maintenance is not completed and approved, that 15% will be forfeited.
- C. 60-Day Payment.** When the second 30 days of the 90-day maintenance are completed and approved, an additional 15% of the total price bid for all plants will be paid, but if the maintenance is not completed and approved, that 15% will be forfeited.

193.1 to 193.3

- D. Final Payment.** When the final 30 days of the 90-day maintenance are completed and approved, and after final inspection and acceptance, an additional 15% of the total price bid for all plants will be paid, but if the maintenance is not completed and approved, that 15% will be forfeited.

When mulch, plant soil mix, landscape edge, plant bed preparation, and vegetation barrier are specified as separate pay items, the work performed and materials furnished in accordance with this Item and measured as provided under “Measurement” will be paid for at the unit price bid for “Mulch,” “Plant Soil Mix,” “Landscape Edge,” “Plant Bed Preparation,” and “Vegetation Barrier.” Each price is full compensation for materials, equipment, labor, tools, and incidentals.

ITEM 193

LANDSCAPE ESTABLISHMENT

193.1. Description. Establish landscape plantings and maintain landscaped areas at designated locations. If used with Item 192, “Landscape Planting,” begin this Item after the final payment is approved in accordance with Article 192.5.D, “Final Payment.”

193.2. Materials. Unless otherwise shown on the plans, furnish the following materials:

- fertilizer in accordance with Article 166.2, “Materials”;
- mulch consisting of loose organic materials such as wood chips or shredded bark that is free from harmful chemicals, soil, and other foreign matter that may promote compaction of the mulch or cause injury to the plants;
- water that is clean and free of industrial wastes and other substances harmful to the growth of vegetation;
- replacement plants as originally installed or as approved;
- pesticides conforming to the requirements of Section 193.3.A, “Plant Maintenance”;
- supports of the same type as originally installed or as approved; and
- irrigation system replacement parts of the same type and manufacturer as originally installed or approved equal.

193.3. Work Methods. When “Plant Maintenance” or “Irrigation System Operation and Maintenance” are measured by the month, inspect the site at least every 2 weeks, and perform the required maintenance. Perform the

following maintenance activities, and conform to requirements shown on the plans.

- A. Plant Maintenance.** Maintain vegetation within the site in a healthy and vigorous growing condition. Apply pesticides, when required, under the supervision of a person possessing a license in the appropriate use category issued by the Texas Department of Agriculture or the Texas Structural Pest Control Board. Provide documentation of this license, and obtain approval of the pesticides before applications. Pesticide applications must conform to label directions and all pertinent laws and regulations.
- 1. Pruning.** Prune in accordance with ANSI A300 when shown on the plans. Remove dead or dying plants and dead, diseased, or damaged limbs on trees and shrubs. Remove sucker-growth on trunks of trees. Apply an approved wound dressing to all oak (*Quercus*) species within 20 min. of causing bark damage or making a pruning cut. Remove and dispose of pruning debris.
 - 2. Insect, Disease, and Animal Control.** Notify the Engineer in writing of problems with insects, diseases, or animals as such problems arise. Treat the plants or planted areas as directed.
 - 3. Fertilization.** Apply fertilizer uniformly to all plants designated to receive fertilizer.
 - 4. Mulching, Plant Basin, and Plant Bed Maintenance.** Physically remove or apply herbicide to weeds and grasses within plant basins and plant beds before placing additional mulch. Apply and maintain mulch at a depth of 2 in. Maintain plant basins and plant beds free of weeds and grasses, except those that have been treated with herbicides may remain in place until removal is directed. Reshape plant basins and plant beds as necessary to conform to plan details.
 - 5. Mowing, Trimming, and Edging.** Remove and dispose of litter within the designated areas before mowing. Mow and trim grassed areas at the designated height and frequency. Edge where required. Do not use nylon cord trimmers inside plant basins or inside beds containing plant material. Trim vegetation and remove debris from curbs, sidewalks, and other hardscape features.
 - 6. Staking, Guying, and Bracing of Plants.** Stake, guy, or brace plants as directed. Remove support materials when directed, and dispose of removed materials.

193.4 to 193.5

- B. Plant Replacement.** If required on the plans, remove plants selected by the Engineer and replace with plants of the original species, size, and characteristics or with approved substitutes. Replace plants that have been damaged or killed due to the actions or negligence of the Contractor at no additional cost to the Department. Unless otherwise directed, replace plants within the next scheduled work period following notification to begin replacement. Backfill in conformance with the plans or as directed.
- C. Vegetative Watering.** Apply water at the designated rate and frequency to plants or planting areas not serviced by an existing irrigation system. Apply water as directed, adjusting rate and frequency to provide adequate moisture to plant material. Use watering equipment with accurate measuring devices.
- D. Irrigation System Operation and Maintenance.** Maintain the system under the supervision of a person possessing an irrigator's license issued by the TCEQ, and provide documentation of this license. Verify and adhere to all local, state, and federal regulations. Coordinate and obtain required backflow preventer testing at no cost to the Department. Unless otherwise shown on the plans, operate the system using water provided by the Department. Ensure that all zones are functioning properly and providing adequate moisture to plant material using an approved watering schedule. When required, winterize the system to prevent freeze damage in locations where temperatures fall below 32°F. Repair the system using replacement parts of the same type and manufacturer as originally installed or an approved equal. Provide plant irrigation by an approved alternate method at no cost to the Department if the system fails due to the Contractor's actions or neglect.

193.4. Measurement. "Plant Maintenance" will be measured by the month or by the cycle. "Plant Replacement" will be measured by each plant. "Vegetative Watering" will be measured by the 1,000 gal. of water. "Irrigation System Operation and Maintenance" will be measured by the month.

193.5. Payment. The work performed and materials furnished in accordance with this Item and measured as provided under "Measurement" will be paid for at the unit price bid for "Plant Maintenance," "Plant Replacement" of the size specified, "Plant Replacement" of the size and type specified, "Plant Replacement" of the group specified, "Vegetative Watering," and "Irrigation System Operation and Maintenance." This price is full compensation for furnishing and operating equipment and for litter

pickup, mowing, trimming, edging, pruning, fertilizer, labor, materials, tools, and incidentals. Plant replacement needed due to Contractor negligence will be at no additional cost to the Department.

200 ITEMS — SUBGRADE TREATMENTS AND BASE**ITEM 204
SPRINKLING**

204.1. Description. Apply water for dust control, earthwork, or base construction.

204.2. Materials. Furnish water free of industrial wastes and other objectionable matter.

204.3. Equipment. Use sprinklers and spray bars equipped with positive and rapidly working cut-off valves.

204.4. Construction. Apply water at a uniform rate and in the required quantity, or as directed.

204.5. Measurement. This Item will be measured by the 1,000 gal. applied.

204.6. Payment. Unless sprinkling is specified as a pay item, the work performed and materials furnished in accordance with this Item will not be paid for directly but will be subsidiary to pertinent Items.

When sprinkling is specified on the plans as a pay item, the work performed and water furnished will be paid for at the unit price bid for “Sprinkling (Base),” “Sprinkling (Earthwork),” or “Sprinkling (Dust Control).” This price is full compensation for furnishing and applying water; furnishing and operating sprinklers and measuring devices; and hauling, equipment, labor, fuel, materials, tools, and incidentals.

**ITEM 210
ROLLING**

210.1. Description. Compact embankment, subgrade, base, surface treatments, broken concrete pavement, or asphalt pavement using rollers. Break up asphalt mats, pit run material, or base materials.

210.2. Equipment. The Contractor may use any type of roller to meet the production rates and quality requirements of the Contract unless otherwise shown on the plans or directed. When specific types of equipment are

210.2 to 210.2

required, use equipment that meets the requirements of this Article. The Engineer may allow the use of rollers that operate in one direction only when turning does not affect the quality of work or encroach on traffic.

**Table 1
Roller Requirements¹**

Roller Type	Materials to be Compacted	Load (tons)	Contact Pressure	Roller Speed (mph)
Steel wheel	Embankment, subgrade, base, asphalt concrete	≥ 10	≥ 325 lb. per linear inch of wheel width	2–3
Tamping	Embankment, subgrade, base	–	125–550 psi per tamping foot	2–3
Heavy tamping	Embankment, subgrade, base	–	≤ 550 psi per tamping foot	2–3
Vibratory	Embankment, subgrade, base, asphalt concrete	Type A < 6 Type B > 6 Type C as shown on plans	Per equipment specification and as approved	As approved
Light pneumatic	Embankment, subgrade, base, surface treatment	4.5–9.0	≥ 45 psi	2–6
	Asphalt Concrete			4–12
Medium pneumatic	Same as light pneumatic	12–25	≥ 80 psi, as directed	Same as light pneumatic
Heavy pneumatic	Embankment, subgrade, base, previously broken concrete pavement, other pavements	≥ 25	≤ 150 psi	2–6
Grid	Embankment, base, breaking up existing asphalt mats or base	5–13	–	2–3

1. Unless otherwise specified in the Contract.

- A. Static Steel Wheel Rollers.** Furnish single, double, or triple steel wheel, self-propelled power rollers weighing at least 10 tons capable of

operating in a forward and backward motion. Ensure all wheels are flat. When static steel wheel rollers are required, vibratory rollers in the static mode may be used.

For single steel wheel rollers, pneumatic rear wheels are allowed for embankment, subgrade, and base. For triple steel wheel rollers, provide rear wheels with a minimum diameter of 48 in., a minimum width of 20 in., and a minimum compression of 325 lb. per inch of wheel width.

B. Tamping Rollers. Furnish self-propelled rollers with at least 1 self-cleaning metal tamping drum capable of operating in a forward or backward motion with a minimum effective rolling width of 5 ft. For rollers with more than 1 drum, mount drums in a frame so that each drum moves independently of the other. Operate rollers in static or vibratory mode.

1. Tamping Roller (Minimum Requirement). For all tamping rollers except for heavy tamping rollers, provide tamping feet that exert a static load of 125 to 550 psi and project at least 3 in. from the surface of the drum.

2. Heavy Tamping Roller. Provide tamping rollers that have:

- 2 metal tamping drums, rolls, or shells, each with a 60-in. minimum diameter and a 5-ft. minimum width, or
- 1 rear and 2 forward drums, each with a 60-in. minimum diameter. Arrange drums so that the rear drum compacts the space between the 2 forward drums and the minimum overall rolling width is 10 ft.

Equip drums with tamping feet that:

- project at least 7 in. from the drum surface,
- have an area of 7 to 21 sq. in.,
- are self-cleaning,
- exert a static load of at least 550 psi, and
- are spaced at 1 tamping foot per 0.65 to 0.70 sq. ft. of drum area.

C. Vibratory Rollers. Furnish self-propelled rollers with at least 1 drum equipped to vibrate. Select and maintain amplitude and frequency settings per manufacturer's specifications to deliver maximum compaction without material displacement or shoving, as approved. Furnish the equipment manufacturer's specifications concerning settings and controls for amplitude and frequency. Operate rollers at speeds that will produce at least 10 blows per foot unless otherwise shown on the plans or approved. Pneumatic rear wheels are allowed for embankment, subgrade, and base. Equip each vibrating drum with:

210.2 to 210.2

- separate frequency and amplitude controls,
- controls to manually start and stop vibration, and
- a mechanism to continuously clean the face of the drum.

For asphalt-stabilized base and asphalt concrete pavement, furnish a roller that also has the ability to:

- automatically reverse the direction of the rotating eccentric weight,
- stop vibration before the motion of the roller stops, and
- thoroughly moisten the drum with water or approved asphalt release agent.

1. **Drum (Type A).** Furnish a roller with a static weight less than 6 tons and a vibratory drum.
2. **Drum (Type B).** Furnish a roller with a minimum static weight of 6 tons and a vibratory drum.
3. **Drum (Type C).** Furnish a roller as shown on plans.

- D. Pneumatic Tire Rollers.** Pneumatic tire rollers consist of rubber tire wheels on axles mounted in a frame with either a loading platform or body suitable for ballast loading. Arrange the rear tires to cover the gaps between adjacent tires of the forward group. Furnish rollers capable of forward and backward motion. Compact asphalt pavements and surface treatments with a roller equipped with smooth-tread tires. Compact without damaging the surface. When necessary, moisten the wheels with water or an approved asphalt release agent.

Select and maintain the operating load and tire air pressure within the range of the manufacturer's charts or tabulations to attain maximum compaction throughout the lift, as approved. Furnish the manufacturer's chart or tabulations showing the contact areas and contact pressures for the full range of tire inflation pressures and for the full range of loadings for the particular tires furnished. Maintain individual tire inflation pressures within 5 psi of each other. Provide uniform compression under all tires.

1. **Light Pneumatic Tire.** Furnish a unit:
 - with at least 9 pneumatic tires,
 - with an effective rolling width of approximately 5 ft.,
 - capable of providing a total uniform load of 4.5 to 9 tons, and
 - with tires capable of maintaining a minimum ground contact pressure of 45 psi.
2. **Medium Pneumatic Tire.** Furnish a unit:
 - with at least 7 pneumatic tires,
 - with an effective rolling width of approximately 7 ft.,

- capable of providing a total uniform load of 12 to 25 tons, and
 - with tires capable of maintaining a minimum ground contact pressure of 80 psi or 90 psi as directed.
3. **Heavy Pneumatic Tire.** Furnish a unit:
- with at least 4 pneumatic-tired wheels mounted on axles carrying at most 2 wheels,
 - with wheels arranged to carry approximately equal loads on uneven surfaces,
 - with a width between 8 and 10 ft. that can turn 180° in the crown width,
 - capable of providing a total uniform load of at least 25 tons,
 - with tires capable of maintaining a maximum ground contact pressure of 150 psi, and
 - with liquid-filled tires inflated to such a level that liquid will flow from the valve stem when the stem is in the uppermost position.
- E. **Grid Rollers.** Furnish rollers that have 2 cylindrical cages with a minimum diameter of 66 in. and a minimum width of 32 in. Mount cages in a rigid frame with weight boxes. Use a cage surface of cast or welded steel fabric grid with bars 1-1/2 in. wide, spaced on 5-in. centers in each direction, that undulate approximately 1 in. between the high and low points.
- Furnish rollers capable of providing a total load of 5 to 13 tons and capable of being operated in a forward or backward motion.
- F. **Alternate Equipment.** Instead of the specified equipment, the Contractor may, as approved, operate other compaction equipment that produces equivalent results. Discontinue the use of the alternate equipment and furnish the specified equipment if the desired results are not achieved.

210.3. Construction. Perform this work in accordance with the applicable Items using equipment and roller speeds specified in Table 1. Use only rubber-tired equipment to push or pull compaction equipment on base courses. Use equipment that does not damage material being rolled.

210.4. Measurement and Payment. The work performed, materials furnished, equipment, labor, tools, and incidentals will not be measured or paid for directly but will be subsidiary to pertinent Items.

216.1 to 247.2

ITEM 216 PROOF ROLLING

216.1. Description. Proof-roll earthwork, base, or both to locate unstable areas.

216.2. Equipment.

- A. Specified Equipment.** Furnish rollers that when loaded weigh at least 25 tons. The maximum acceptable load is 50 tons. Provide rollers that meet the requirements of Section 210.2.D, “Pneumatic Tire Rollers.”
- B. Alternative Equipment.** Instead of the specified equipment, the Contractor may, as approved, operate other compaction equipment that produces equivalent results in the same period of time. Discontinue the use of the alternative equipment and furnish the specified equipment if the desired results are not achieved.

216.3. Construction. Perform proof rolling as directed. Adjust the load and tire inflation pressures within the range of the manufacturer’s charts or tabulations, as directed. Make at least 2 coverages with the proof roller. Offset each trip of the roller by at most 1 tire width. Operate rollers at a speed between 2 and 6 miles per hour, as directed. If an unstable or non-uniform area is found, correct the area in accordance with the applicable Item.

216.4. Measurement. Rolling will be measured by the hour operated on surfaces being tested.

216.5. Payment. The work performed and equipment furnished in accordance with this Item and measured as provided under “Measurement” will be paid for at the unit price bid for “Proof Rolling.” This price is full compensation for furnishing and operating equipment and for labor, materials, tools, and incidentals.

ITEM 247 FLEXIBLE BASE

247.1. Description. Construct a foundation course composed of flexible base.

247.2. Materials. Furnish uncontaminated materials of uniform quality that meet the requirements of the plans and specifications. Notify the Engineer

of the proposed material sources and of changes to material sources. The Engineer may sample and test project materials at any time before compaction throughout the duration of the project to assure specification compliance. Use Tex-100-E material definitions.

- A. Aggregate.** Furnish aggregate of the type and grade shown on the plans and conforming to the requirements of Table 1. Each source must meet Table 1 requirements for liquid limit, plasticity index, and wet ball mill for the grade specified. Do not use additives such as but not limited to lime, cement, or fly ash to modify aggregates to meet the requirements of Table 1, unless shown on the plans.

Table 1
Material Requirements

Property	Test Method	Grade 1	Grade 2	Grade 3	Grade 4
Master gradation sieve size (% retained)	Tex-110-E				As shown on the plans
2-1/2 in.		–	0	0	
1-3/4 in.		0	0–10	0–10	
7/8 in.		10–35	–	–	
3/8 in.		30–50	–	–	
No. 4		45–65	45–75	45–75	
No. 40		70–85	60–85	50–85	
Liquid limit, % max. ¹	Tex-104-E	35	40	40	As shown on the plans
Plasticity index, max. ¹	Tex-106-E	10	12	12	As shown on the plans
Plasticity index, min. ¹		As shown on the plans			
Wet ball mill, % max. ²	Tex-116-E	40	45	–	As shown on the plans
Wet ball mill, % max. increase passing the No. 40 sieve		20	20	–	
Classification ³	Tex-117-E	1.0	1.1–2.3	–	As shown on the plans
Min. compressive strength ³ , psi					As shown on the plans
lateral pressure 0 psi		45	35	–	
lateral pressure 15 psi		175	175	–	

1. Determine plastic index in accordance with Tex-107-E (linear shrinkage) when liquid limit is unattainable as defined in Tex-104-E.

2. When a soundness value is required by the plans, test material in accordance with Tex-411-A.

3. Meet both the classification and the minimum compressive strength, unless otherwise shown on the plans.

247.2 to 247.2

- 1. Material Tolerances.** The Engineer may accept material if no more than 1 of the 5 most recent gradation tests has an individual sieve outside the specified limits of the gradation.

When target grading is required by the plans, no single failing test may exceed the master grading by more than 5 percentage points on sieves No. 4 and larger or 3 percentage points on sieves smaller than No. 4.

The Engineer may accept material if no more than 1 of the 5 most recent plasticity index tests is outside the specified limit. No single failing test may exceed the allowable limit by more than 2 points.

- 2. Material Types.** Do not use fillers or binders unless approved. Furnish the type specified on the plans in accordance with the following.
 - a. Type A.** Crushed stone produced and graded from oversize quarried aggregate that originates from a single, naturally occurring source. Do not use gravel or multiple sources.
 - b. Type B.** Crushed or uncrushed gravel. Blending of 2 or more sources is allowed.
 - c. Type C.** Crushed gravel with a minimum of 60% of the particles retained on a No. 4 sieve with 2 or more crushed faces as determined by Tex-460-A, Part I. Blending of 2 or more sources is allowed.
 - d. Type D.** Type A material or crushed concrete. Crushed concrete containing gravel will be considered Type D material. Crushed concrete must meet the requirements in Section 247.2.A.3.b, "Recycled Material (Including Crushed Concrete) Requirements," and be managed in a way to provide for uniform quality. The Engineer may require separate dedicated stockpiles in order to verify compliance.
 - e. Type E.** As shown on the plans.
- 3. Recycled Material.** Recycled asphalt pavement (RAP) and other recycled materials may be used when shown on the plans. Request approval to blend 2 or more sources of recycled materials.
 - a. Limits on Percentage.** When RAP is allowed, do not exceed 20% RAP by weight unless otherwise shown on the plans. The percentage limitations for other recycled materials will be as shown on the plans.

b. Recycled Material (Including Crushed Concrete) Requirements.

(1) Contractor Furnished Recycled Materials. When the Contractor furnishes the recycled materials, including crushed concrete, the final product will be subject to the requirements of Table 1 for the grade specified. Certify compliance with DMS-11000, "Evaluating and Using Nonhazardous Recyclable Materials Guidelines," for Contractor furnished recycled materials. In addition, recycled materials must be free from reinforcing steel and other objectionable material and have at most 1.5% deleterious material when tested in accordance with Tex-413-A. For RAP, do not exceed a maximum percent loss from decantation of 5.0% when tested in accordance with Tex-406-A. Test RAP without removing the asphalt.

(2) Department Furnished Required Recycled Materials. When the Department furnishes and requires the use of recycled materials, unless otherwise shown on the plans:

- Department required recycled material will not be subject to the requirements in Table 1,
- Contractor furnished materials are subject to the requirements in Table 1 and this Item,
- the final product, blended, will be subject to the requirements in Table 1, and
- for final product, unblended (100% Department furnished required recycled material), the liquid limit, plasticity index, wet ball mill, classification, and compressive strength is waived.

Crush Department-furnished RAP so that 100% passes the 2 in. sieve. The Contractor is responsible for uniformly blending to meet the percentage required.

(3) Department Furnished and Allowed Recycled Materials. When the Department furnishes and allows the use of recycled materials or allows the Contractor to furnish recycled materials, the final blended product is subject to the requirements of Table 1 and the plans.

c. Recycled Material Sources. Department-owned recycled material is available to the Contractor only when shown on the plans. Return unused Department-owned recycled materials to

247.3 to 247.4

the Department stockpile location designated by the Engineer unless otherwise shown on the plans.

The use of Contractor-owned recycled materials is allowed when shown on the plans. Contractor-owned surplus recycled materials remain the property of the Contractor. Remove Contractor-owned recycled materials from the project and dispose of them in accordance with federal, state, and local regulations before project acceptance. Do not intermingle Contractor-owned recycled material with Department-owned recycled material unless approved by the Engineer.

- B. Water.** Furnish water free of industrial wastes and other objectionable matter.
- C. Material Sources.** When non-commercial sources are used, expose the vertical faces of all strata of material proposed for use. Secure and process the material by successive vertical cuts extending through all exposed strata, when directed.

247.3. Equipment. Provide machinery, tools, and equipment necessary for proper execution of the work. Provide rollers in accordance with Item 210, "Rolling." Provide proof rollers in accordance with Item 216, "Proof Rolling," when required.

247.4. Construction. Construct each layer uniformly, free of loose or segregated areas, and with the required density and moisture content. Provide a smooth surface that conforms to the typical sections, lines, and grades shown on the plans or as directed.

Stockpile base material temporarily at an approved location before delivery to the roadway. Build stockpiles in layers no greater than 2 ft. thick. Stockpiles must have a total height between 10 and 16 ft. unless otherwise shown on the plans. After construction and acceptance of the stockpile, loading from the stockpile for delivery is allowed. Load by making successive vertical cuts through the entire depth of the stockpile.

Do not add or remove material from temporary stockpiles that require sampling and testing before delivery unless otherwise approved. Charges for additional sampling and testing required as a result of adding or removing material will be deducted from the Contractor's estimates.

Haul approved flexible base in clean trucks. Deliver the required quantity to each 100-ft. station or designated stockpile site as shown on the plans. Prepare stockpile sites as directed. When delivery is to the 100-ft. station, manipulate in accordance with the applicable Items.

- A. Preparation of Subgrade or Existing Base.** Remove or scarify existing asphalt concrete pavement in accordance with Item 105, “Removing Stabilized Base and Asphalt Pavement,” when shown on the plans or as directed. Shape the subgrade or existing base to conform to the typical sections shown on the plans or as directed.

When new base is required to be mixed with existing base, deliver, place, and spread the new flexible base in the required amount per station. Manipulate and thoroughly mix the new base with existing material to provide a uniform mixture to the specified depth before shaping.

When shown on the plans or directed, proof roll the roadbed in accordance with Item 216, “Proof Rolling,” before pulverizing or scarifying. Correct soft spots as directed.

- B. Placing.** Spread and shape flexible base into a uniform layer with an approved spreader the same day as delivered unless otherwise approved. Construct layers to the thickness shown on the plans. Maintain the shape of the course. Control dust by sprinkling, as directed. Correct or replace segregated areas as directed, at no additional expense to the Department.

Place successive base courses and finish courses using the same construction methods required for the first course.

- C. Compaction.** Compact using density control unless otherwise shown on the plans. Multiple lifts are permitted when shown on the plans or approved. Bring each layer to the moisture content directed. When necessary, sprinkle the material in accordance with Item 204, “Sprinkling.”

Begin rolling longitudinally at the sides and proceed towards the center, overlapping on successive trips by at least 1/2 the width of the roller unit. On superelevated curves, begin rolling at the low side and progress toward the high side. Offset alternate trips of the roller. Operate rollers at a speed between 2 and 6 mph as directed.

Rework, recompact, and refinish material that fails to meet or that loses required moisture, density, stability, or finish before the next course is placed or the project is accepted. Continue work until specification requirements are met. Perform the work at no additional expense to the Department.

- 1. Ordinary Compaction.** Roll with approved compaction equipment as directed. Correct irregularities, depressions, and weak spots immediately by scarifying the areas affected, adding or

247.5 to 247.5

removing approved material as required, reshaping, and recompacting.

2. **Density Control.** Compact to at least 100% of the maximum density determined by Tex-113-E unless otherwise shown on the plans. Determine the moisture content of the material at the beginning and during compaction in accordance with Tex-103-E.

The Engineer will determine roadway density of completed sections in accordance with Tex-115-E. The Engineer may accept the section if no more than 1 of the 5 most recent density tests is below the specified density and the failing test is no more than 3 pcf below the specified density.

- D. **Finishing.** After completing compaction, clip, skin, or tight-blade the surface with a maintainer or subgrade trimmer to a depth of approximately 1/4 in. Remove loosened material and dispose of it at an approved location. Seal the clipped surface immediately by rolling with a pneumatic tire roller until a smooth surface is attained. Add small increments of water as needed during rolling. Shape and maintain the course and surface in conformity with the typical sections, lines, and grades as shown on the plans or as directed.

In areas where surfacing is to be placed, correct grade deviations greater than 1/4 in. in 16 ft. measured longitudinally or greater than 1/4 in. over the entire width of the cross-section. Correct by loosening, adding, or removing material. Reshape and recompact in accordance with Section 247.4.C, "Compaction."

- E. **Curing.** Cure the finished section until the moisture content is at least 2 percentage points below optimum or as directed before applying the next successive course or prime coat.

247.5. Measurement. Flexible base will be measured as follows:

- **Flexible Base (Complete In Place).** The ton, square yard, or any cubic yard method.
- **Flexible Base (Roadway Delivery).** The ton or cubic yard in vehicle.
- **Flexible Base (Stockpile Delivery).** The ton, cubic yard in vehicle, or cubic yard in stockpile.

Measurement by the cubic yard in final position and square yard is a plans quantity measurement. The quantity to be paid for is the quantity shown in the proposal unless modified by Article 9.2, "Plans Quantity Measurement." Additional measurements or calculations will be made if adjustments of quantities are required.

Measurement is further defined for payment as follows.

- A. Cubic Yard in Vehicle.** By the cubic yard in vehicles of uniform capacity at the point of delivery.
- B. Cubic Yard in Stockpile.** By the cubic yard in the final stockpile position by the method of average end areas.
- C. Cubic Yard in Final Position.** By the cubic yard in the completed and accepted final position. The volume of base course is computed in place by the method of average end areas between the original subgrade or existing base surfaces and the lines, grades, and slopes of the accepted base course as shown on the plans.
- D. Square Yard.** By the square yard of surface area in the completed and accepted final position. The surface area of the base course is based on the width of flexible base as shown on the plans.
- E. Ton.** By the ton of dry weight in vehicles as delivered. The dry weight is determined by deducting the weight of the moisture in the material at the time of weighing from the gross weight of the material. The Engineer will determine the moisture content in the material in accordance with Tex-103-E from samples taken at the time of weighing.

When material is measured in trucks, the weight of the material will be determined on certified scales, or the Contractor must provide a set of standard platform truck scales at a location approved by the Engineer. Scales must conform to the requirements of Item 520, "Weighing and Measuring Equipment."

247.6. Payment. The work performed and materials furnished in accordance with this Item and measured as provided under "Measurement" will be paid for at the unit price bid for the types of work shown below. No additional payment will be made for thickness or width exceeding that shown on the typical section or provided on the plans for cubic yard in the final position or square yard measurement.

Sprinkling and rolling, except proof rolling, will not be paid for directly but will be subsidiary to this Item unless otherwise shown on the plans. When proof rolling is shown on the plans or directed, it will be paid for in accordance with Item 216, "Proof Rolling."

Where subgrade is constructed under this Contract, correction of soft spots in the subgrade will be at the Contractor's expense. Where subgrade is not constructed under this project, correction of soft spots in the subgrade will

251.1 to 251.2

be paid in accordance with pertinent Items or Article 4.2, “Changes in the Work.”

- A. Flexible Base (Complete In Place).** Payment will be made for the type and grade specified. For cubic yard measurement, “In Vehicle,” “In Stockpile,” or “In Final Position” will be specified. For square yard measurement, a depth will be specified. This price is full compensation for furnishing materials, temporary stockpiling, assistance provided in stockpile sampling and operations to level stockpiles for measurement, loading, hauling, delivery of materials, spreading, blading, mixing, shaping, placing, compacting, reworking, finishing, correcting locations where thickness is deficient, curing, furnishing scales and labor for weighing and measuring, and equipment, labor, tools, and incidentals.
- B. Flexible Base (Roadway Delivery).** Payment will be made for the type and grade specified. For cubic yard measurement, “In Vehicle” will be specified. The unit price bid will not include processing at the roadway. This price is full compensation for furnishing materials, temporary stockpiling, assistance provided in stockpile sampling and operations to level stockpiles for measurement, loading, hauling, delivery of materials, furnishing scales and labor for weighing and measuring, and equipment, labor, tools, and incidentals.
- C. Flexible Base (Stockpile Delivery).** Payment will be made for the type and grade specified. For cubic yard measurement, “In Vehicle” or “In Stockpile” will be specified. The unit price bid will not include processing at the roadway. This price is full compensation for furnishing and disposing of materials, preparing the stockpile area, temporary or permanent stockpiling, assistance provided in stockpile sampling and operations to level stockpiles for measurement, loading, hauling, delivery of materials to the stockpile, furnishing scales and labor for weighing and measuring, and equipment, labor, tools, and incidentals.

ITEM 251

REWORKING BASE COURSES

251.1. Description. Refinish existing base material or rework existing base material with or without asphaltic concrete pavement. Incorporate new base material when shown on plans.

251.2. Materials. Furnish uncontaminated materials of uniform quality that meet the requirements of the plans and specifications. Notify the Engineer

of the proposed material sources and of changes to material sources. The Engineer will verify that the specification requirements are met before the sources can be used. The Engineer may sample and test project materials at any time before compaction. Use Tex-100-E for material definitions.

- A. **Flexible Base.** Furnish new base material that meets the requirements of Item 247, "Flexible Base," for the type and grade shown on the plans.
- B. **Water.** Furnish water free of industrial wastes and other objectionable matter.

251.3. Equipment. Provide machinery, tools, and equipment necessary for proper execution of the work.

- A. **Compaction Equipment.** Provide rollers in accordance with Item 210, "Rolling." Provide rollers in accordance with Item 216, "Proof Rolling," when required.
- B. **Pulverization Equipment.** Provide pulverization equipment that:
 - cuts and pulverizes material uniformly to the proper depth with cutters that plane to a uniform surface over the entire width of the cut,
 - provides a visible indication of the depth of cut at all times, and
 - uniformly mixes the materials.

251.4. Construction. Perform work to the width and depth shown on the typical sections for the type of work shown on the plans. Construct and shape exposed subgrade to conform to typical sections as shown on the plans or as directed. Proof roll in accordance with Item 216, "Proof Rolling," when shown on the plans. Correct soft spots as directed.

Before scarifying, clean the existing base of objectionable materials by blading, brooming, or other approved methods, unless otherwise shown on the plans. Perform this work in accordance with applicable Items.

A. Types of Work:

1. **Type A.** Scarifying only.
2. **Type B.** Scarifying, salvaging, and replacing.
3. **Type C.** Scarifying, salvaging, and stockpiling.
4. **Type D.** Scarifying and reshaping.
5. **Type E.** Refinishing.

B. Performance of Work.

1. **Scarifying.** Loosen and break existing base material, with or without existing asphaltic concrete pavement. Remove asphalt concrete pavement, surface treatment, plant-mix seal, and micro-surfacing when shown on the plans and in accordance with applicable items. Prevent contamination of asphalt material during and after removal. When the existing pavement consists of only a surface treatment, do not remove before scarifying. Scarify existing material for its full width and depth, unless otherwise shown on the plans. Do not disturb the underlying subgrade. Break material into particles of not more than 2-1/2 in., unless otherwise shown on the plans.
2. **Salvaging.** Remove the existing base material and stockpile. Windrow if allowed. Perform salvage operations without interfering with traffic, proper drainage, or the general requirements of the work. Remove scarified material using a method approved by the Engineer. Keep material free of contamination.
3. **Replacing.** Before replacing salvaged material, prepare subgrade as shown on the plans or as directed. Proof roll in accordance with Item 216, "Proof Rolling," when shown on the plans. Correct soft spots as directed.

Return and rework salvaged base material, with or without additional new base material, on the prepared roadbed. Deposit salvaged material on the prepared subgrade and sprinkle, blade, and shape the base to conform to the typical sections shown on the plans or as directed. When shown on the plans, place new base material and uniformly mix with salvaged material. Correct, or remove and replace, segregated material with satisfactory material, as directed.

4. **Stockpiling.** Store salvaged base material at a location shown on the plans or as directed. Prepare stockpile sites by removing and disposing of trash, wood, brush, stumps, vegetation, and other objectionable materials as directed. Deliver salvaged material and construct stockpiles as directed.
5. **Reshaping.** Rework scarified base material with or without additional new base material. Mix and shape scarified base to conform to the typical sections shown on the plans. When shown on the plans, furnish new base material, and uniformly mix with

scarified material before shaping. Do not disturb the underlying subgrade. Correct, or remove and replace, segregated material with satisfactory material as directed.

6. **Refinishing.** Blade existing base surface to remove irregularities. Cure before placing the pavement on the refinished base, as shown on the plans or as directed.

- C. **Compaction.** Compact using ordinary compaction or density control as shown on the plans. Bring each layer to the moisture content directed. When necessary, sprinkle the material in accordance with Item 204, "Sprinkling."

Begin rolling longitudinally at the sides and proceed toward the center, overlapping on successive trips by at least one-half the width of the roller unit. On superelevated curves, begin rolling at the low side and progress toward the high side. Offset alternate trips of the roller. Operate rollers at a speed between 2 and 6 MPH, as directed.

Rework, recompact, and refinish material that fails to meet or that loses required moisture, density, stability, or finish before the next course is placed or the project is accepted. Continue work until specification requirements are met. Perform the work at no additional expense to the Department.

1. **Ordinary Compaction.** Roll with approved compaction equipment as directed. Correct irregularities, depressions, and weak spots immediately by scarifying the areas affected, adding or removing approved material as required, reshaping, and recompacting.
2. **Density Control.** Determine the moisture content in the mixture at the beginning of and during compaction in accordance with Tex-103-E. Compact to at least 98% of the maximum density determined by Tex-113-E, unless otherwise shown on the plans.

The Engineer will determine roadway density of completed sections in accordance with Tex-115-E. The Engineer may accept the section if no more than 1 of the 5 most recent density tests is below the specified density and the failing test is no more than 3 pcf below the specified density.

- D. **Finishing.** Immediately after completing compaction, clip, skin, or tight-blade the surface with a maintainer or subgrade trimmer to a depth of approximately 1/4 in. Remove and dispose of loosened material at an approved location. Seal the clipped surface immediately by rolling with a pneumatic tire roller until a smooth surface is attained. Add small

251.5 to 251.5

amounts of water as needed during rolling. Shape and maintain the course and surface in conformity with the typical sections, lines, and grades shown on the plans or as directed.

In areas where surfacing is to be placed, correct grade deviations in excess of 1/4 in. in 16 ft. measured longitudinally for the entire width of the cross-section. Correct by loosening, adding, or removing material. Reshape and recompact in accordance with Section 251.4.C, "Compaction."

- E. **Curing.** Cure the finished section until the moisture content is at least 2 percentage points below optimum or as directed before applying the next successive course or prime coat.

251.5. Measurement. This Item will be measured by the station, square yard, cubic yard, or ton.

Square yard and cubic yard in original position measurement will be established by the widths and depths shown in the plans and the lengths measured in the field.

When material is measured in trucks, the weight of the material will be determined on certified scales, or the Contractor must provide a set of standard platform truck scales at a location approved by the Engineer. Scales must conform to the requirements of Item 520, "Weighing and Measuring Equipment."

Measurement is further defined for payment as follows.

- A. **Station.** By the 100-ft. station measured along the centerline of each roadbed.
- B. **Square Yard.** By the square yard of existing base or pavement in its original position. When square yard measurement is used, limits of measurement will be as shown on the plans.
- C. **Cubic Yard in Vehicle.** By the cubic yard of salvaged material in vehicles as delivered at the stockpile.
- D. **Cubic Yard in Stockpile.** By the cubic yard of salvaged material in the final stockpile position by the method of average end areas.
- E. **Cubic Yard in Original Position.** By the cubic yard in its original position measured by the method of average end areas.
- F. **Ton.** By the ton of dry weight in the trucks as delivered at the stockpile. The dry weight is determined by deducting the weight of the moisture in the material at the time of weighing from the gross weight of the material. The Engineer will determine the moisture content in the

material in accordance with Tex-103-E from samples taken at the time of truck weighing.

251.6. Payment. The work performed and materials furnished in accordance with this Item and measured as provided under “Measurement” will be paid for at the unit price bid for “Reworking Base Material” for the type, scarified depth, and compaction method shown on the plans. For cubic yard measurements, the measurement location (vehicle, stockpile, or original position) will be specified. No additional payment will be made for thickness or width exceeding that shown on the typical sections or provided on the plans for station, square yard, and cubic yard in the original position measurement. This price is full compensation for furnishing and disposing of materials, blading, brooming, scarifying, salvaging, replacing, stockpiling, reshaping, refinishing, compacting, finishing, curing, and equipment, labor, tools, and incidentals.

Furnishing and delivering new base will be paid for in accordance with Section 247.6.B, “Flexible Base (Roadway Delivery).” Mixing, spreading, blading, shaping, compacting, and finishing new or existing base material will not be paid for directly, but will be subsidiary to this Item.

Sprinkling and rolling, except proof rolling, will not be paid for directly but will be subsidiary to this Item, unless otherwise shown on the plans. When proof rolling is shown on the plans or directed by the Engineer, it will be paid for in accordance with Item 216, “Proof Rolling.”

Where subgrade is constructed under this Contract, correction of soft spots in the subgrade or existing base will be at the Contractor’s expense. Where subgrade is not constructed under this Contract, correction of soft spots in the subgrade or existing base will be in accordance with pertinent Items or Article 4.2, “Changes in the Work.”

Removal of existing asphalt concrete pavement will be paid for in accordance with pertinent Items or Article 4.2, “Changes in the Work.”

Additional restrictions for measurement and payment are as follows:

- **Type A.** Work will be restricted to station and square yard measurement.
- **Type B.** Work will be restricted to station, square yard, and cubic yard in the original position measurement.
- **Type C.** Work will not be restricted to any measurement.
- **Type D.** Work will be restricted to station, square yard, and cubic yard in the original position measurement.
- **Type E.** Work will be restricted to station and square yard measurement.

260.1 to 260.3

ITEM 260

LIME TREATMENT (ROAD-MIXED)

260.1. Description. Mix and compact lime, water, and subgrade or base (with or without asphaltic concrete pavement) in the roadway.

260.2. Materials. Furnish uncontaminated materials of uniform quality that meet the requirements of the plans and specifications. Notify the Engineer of the proposed material sources and of changes to material sources. Obtain verification from the Engineer that the specification requirements are met before using the sources. The Engineer may sample and test project materials at any time before compaction. Use Tex-100-E for material definitions.

- A. Lime.** Furnish lime that meets the requirements of DMS-6350 “Lime and Lime Slurry,” and DMS-6330, “Lime Sources Prequalification of Hydrated Lime and Quicklime.” Use hydrated lime, commercial lime slurry, or quicklime, as shown on the plans. When furnishing quicklime, provide it in bulk.
- B. Flexible Base.** Furnish base material that meets the requirements of Item 247, “Flexible Base,” for the type and grade shown on the plans, before the addition of lime.
- C. Water.** Furnish water free of industrial wastes and other objectionable material.
- D. Asphalt.** When asphalt or emulsion is permitted for curing purposes, furnish materials that meet the requirements of Item 300, “Asphalts, Oils, and Emulsions,” as shown on the plans or as directed.
- E. Mix Design.** The Engineer will determine the target lime content and optimum moisture content in accordance with Tex-121-E or prior experience with the project materials. The Contractor may propose a mix design developed in accordance with Tex-121-E. The Engineer will use Tex-121-E to verify the Contractor’s proposed mix design before acceptance. Reimburse the Department for subsequent mix designs or partial designs necessitated by changes in the material or requests by the Contractor. When treating existing materials, limit the amount of asphalt concrete pavement to no more than 50% of the mix unless otherwise shown on the plans or directed.

260.3. Equipment. Provide machinery, tools, and equipment necessary for proper execution of the work. Provide rollers in accordance with Item 210,

“Rolling.” Provide proof rollers in accordance with Item 216, “Proof Rolling,” when required.

- A. Storage Facility.** Store quicklime and dry hydrated lime in closed, weatherproof containers.
- B. Slurry Equipment.** Use slurry tanks equipped with agitation devices to slurry hydrated lime or quicklime on the project or other approved location. The Engineer may approve other slurring methods.

Provide a pump for agitating the slurry when the distributor truck is not equipped with an agitator. Equip the distributor truck with a sampling device in accordance with Tex-600-J, Part I, when using commercial lime slurry.

- C. Pulverization Equipment.** Provide pulverization equipment that:
- cuts and pulverizes material uniformly to the proper depth with cutters that plane to a uniform surface over the entire width of the cut,
 - provides a visible indication of the depth of cut at all times, and
 - uniformly mixes the materials.

260.4. Construction. Construct each layer uniformly, free of loose or segregated areas, and with the required density and moisture content. Provide a smooth surface that conforms to the typical sections, lines, and grades shown on the plans or as directed.

- A. Preparation of Subgrade or Existing Base for Treatment.** Before treating, remove existing asphalt concrete pavement in accordance with Item 105, “Removing Stabilized Base and Asphalt Pavement,” when shown on the plans or as directed. Shape existing material in accordance with applicable bid items to conform to typical sections shown on the plans and as directed.

When shown on the plans or directed, proof roll the roadbed in accordance with Item 216, “Proof Rolling,” before pulverizing or scarifying existing material. Correct soft spots as directed.

When new base material is required to be mixed with existing base, deliver, place, and spread the new material in the required amount per station. Manipulate and thoroughly mix new base with existing material to provide a uniform mixture to the specified depth before shaping.

- B. Pulverization.** Pulverize or scarify existing material after shaping so that 100% passes a 2-1/2-in. sieve. If the material cannot be uniformly processed to the required depth in a single pass, excavate and windrow

260.4 to 260.4

the material to expose a secondary grade to achieve processing to plan depth.

- C. Application of Lime.** Uniformly apply lime using dry or slurry placement as shown on the plans or as directed. Add lime at the percentage determined in Section 260.2.E, "Mix Design." Apply lime only on an area where mixing can be completed during the same working day.

Start lime application only when the air temperature is at least 35°F and rising or is at least 40°F. The temperature will be taken in the shade and away from artificial heat. Suspend application when the Engineer determines that weather conditions are unsuitable.

Minimize dust and scattering of lime by wind. Do not apply lime when wind conditions, in the opinion of the Engineer, cause blowing lime to become dangerous to traffic or objectionable to adjacent property owners. When pebble grade quicklime is placed dry, mix the material and lime thoroughly at the time of lime application. *Use of quicklime can be dangerous. Inform users of the recommended precautions for handling and storage.*

- 1. Dry Placement.** Before applying lime, bring the prepared roadway to approximately optimum moisture content. When necessary, sprinkle in accordance with Item 204, "Sprinkling." Distribute the required quantity of hydrated lime or pebble grade quicklime with approved equipment. Only hydrated lime may be distributed by bag. Do not use a motor grader to spread hydrated lime.
- 2. Slurry Placement.** Provide slurry free of objectionable materials, at or above the approved minimum dry solids content, and with a uniform consistency that will allow ease of handling and uniform application. Deliver commercial lime slurry to the jobsite or prepare lime slurry at the jobsite or other approved location by using hydrated lime or quicklime, as specified.

Distribute slurry uniformly by making successive passes over a measured section of roadway until the specified lime content is reached. Uniformly spread the residue from quicklime slurry over the length of the roadway being processed, unless otherwise directed.

- D. Mixing.** Begin mixing within 6 hours of application of lime. Hydrated lime exposed to the open air for 6 hours or more between application and mixing, or that experiences excessive loss due to washing or blowing, will not be accepted for payment.

Thoroughly mix the material and lime using approved equipment. Allow the mixture to mellow for 1 to 4 days, as directed. When pebble grade quicklime is used, allow the mixture to mellow for 2 to 4 days, as directed. Sprinkle the treated materials during the mixing and mellowing operation, as directed, to achieve adequate hydration and proper moisture content. After mellowing, resume mixing until a homogeneous, friable mixture is obtained.

After mixing, the Engineer will sample the mixture at roadway moisture and test in accordance with Tex-101-E, Part III, to determine compliance with the gradation requirements in Table 1.

Table 1
Gradation Requirements (Minimum % Passing)

Sieve Size	Base	Subgrade
1-3/4 in.	100	100
3/4 in.	85	85
No. 4	—	60

- E. Compaction.** Compact the mixture using density control, unless otherwise shown on the plans. Multiple lifts are permitted when shown on the plans or approved. Bring each layer to the moisture content directed. When necessary, sprinkle the treated material in accordance with Item 204, “Sprinkling.” Determine the moisture content of the mixture at the beginning and during compaction in accordance with Tex-103-E.

Begin rolling longitudinally at the sides and proceed toward the center, overlapping on successive trips by at least one-half the width of the roller unit. On superelevated curves, begin rolling at the low side and progress toward the high side. Offset alternate trips of the roller. Operate rollers at a speed between 2 and 6 MPH, as directed.

Rework, recompact, and refinish material that fails to meet or that loses required moisture, density, stability, or finish before the next course is placed or the project is accepted. Continue work until specification requirements are met. Rework in accordance with Section 260.4.F, “Reworking a Section.” Perform the work at no additional expense to the Department.

- 1. Ordinary Compaction.** Roll with approved compaction equipment, as directed. Correct irregularities, depressions, and weak spots immediately by scarifying the areas affected, adding or

260.4 to 260.4

removing treated material as required, reshaping, and recompacting.

2. **Density Control.** The Engineer will determine roadway density of completed sections in accordance with Tex-115-E. The Engineer may accept the section if no more than 1 of the 5 most recent density tests is below the specified density and the failing test is no more than 3 pcf below the specified density.
 - a. **Subgrade.** Compact to at least 95% of the maximum density determined in accordance with Tex-121-E, unless otherwise shown on the plans.
 - b. **Base.** Compact the bottom course to at least 95% of the maximum density determined in accordance with Tex-121-E, unless otherwise shown on the plans. Compact subsequent courses treated under this Item to at least 98% of the maximum density determined in accordance with Tex-121-E, unless otherwise shown on the plans.
- F. **Reworking a Section.** When a section is reworked within 72 hours after completion of compaction, rework the section to provide the required density. When a section is reworked more than 72 hr. after completion of compaction, add additional lime at 25% of the percentage determined in Section 260.2.E, "Mix Design." Reworking includes loosening, adding material or removing unacceptable material if necessary, mixing as directed, compacting, and finishing. When density control is specified, determine a new maximum density of the reworked material in accordance with Tex-121-E, and compact to at least 95% of this density.
- G. **Finishing.** Immediately after completing compaction of the final course, clip, skin, or tight-blade the surface of the lime-treated material with a maintainer or subgrade trimmer to a depth of approximately 1/4 in. Remove loosened material and dispose of at an approved location. Roll the clipped surface immediately with a pneumatic tire roller until a smooth surface is attained. Add small amounts of water as needed during rolling. Shape and maintain the course and surface in conformity with the typical sections, lines, and grades shown on the plans or as directed.

Finish grade of constructed subgrade in accordance with Section 132.3.F.1, "Grade Tolerances." Finish grade of constructed base in accordance with Section 247.4.D, "Finishing."

- H. Curing.** Cure for the minimum number of days shown in Table 2 by sprinkling in accordance with Item 204, “Sprinkling,” or by applying an asphalt material at a rate of 0.05 to 0.20 gal. per square yard as directed. Maintain moisture during curing. Upon completion of curing, maintain the moisture content in accordance with Article 132.3.E, “Maintenance of Moisture and Reworking” for subgrade and Article 247.4.E, “Curing” for bases prior to placing subsequent courses. Do not allow equipment on the finished course during curing except as required for sprinkling, unless otherwise approved. Apply seals or additional courses within 14 calendar days of final compaction.

Table 2
Minimum Curing Requirements Before Placing Subsequent Courses¹

Untreated Material	Curing (Days)
PI ≤ 35	2
PI > 35	5

1. Subject to the approval of the Engineer. Proof rolling may be required as an indicator of adequate curing.

260.5. Measurement.

- A. Lime.** When lime is furnished in trucks, the weight of lime will be determined on certified scales, or the Contractor must provide a set of standard platform truck scales at a location approved by the Engineer. Scales must conform to the requirements of Item 520, “Weighing and Measuring Equipment.”

When lime is furnished in bags, indicate the manufacturer’s certified weight. Bags varying more than 5% from that weight may be rejected. The average weight of bags in any shipment, as determined by weighing 10 bags taken at random, must be at least the manufacturer’s certified weight.

1. Hydrated Lime.

- a. Dry.** Lime will be measured by the ton (dry weight).
- b. Slurry.** Lime slurry will be measured by the ton (dry weight) of the hydrated lime used to prepare the slurry at the job site.

- 2. Commercial Lime Slurry.** Lime slurry will be measured by the ton (dry weight) as calculated from the minimum percent dry solids content of the slurry, multiplied by the weight of the slurry in tons delivered.

260.6 to 260.6

3. Quicklime.

- a. **Dry.** Lime will be measured by the ton (dry weight) of the quicklime.
- b. **Slurry.** Lime slurry will be measured by the ton (dry weight) of the quicklime used to prepare the slurry multiplied by a conversion factor of 1.28 to give the quantity of equivalent hydrated lime, which will be the basis of payment.

B. Lime Treatment. Lime treatment will be measured by the square yard of surface area. The dimensions for determining the surface area are established by the widths shown on the plans and the lengths measured at placement.

260.6. Payment. The work performed and materials furnished in accordance with this Item and measured as provided under “Measurement” will be paid in accordance with Section 260.6.A, “Lime,” or Section 260.6.B, “Lime Treatment.”

Furnishing and delivering new base will be paid for in accordance with Section 247.6.B, “Flexible Base (Roadway Delivery).” Mixing, spreading, blading, shaping, compacting, and finishing new or existing base material will be paid for in accordance with Section 260.6.B, “Lime Treatment.” Removal and disposal of existing asphalt concrete pavement will be paid for in accordance with pertinent Items or Article 4.2, “Changes in the Work.” Sprinkling and rolling, except proof rolling, will not be paid for directly but will be subsidiary to this Item, unless otherwise shown on the plans. When proof rolling is shown on the plans or directed by the Engineer, it will be paid for in accordance with Item 216, “Proof Rolling.”

Where subgrade is constructed under this Contract, correction of soft spots in the subgrade or existing base will be at the Contractor’s expense. Where subgrade is not constructed under this Contract, correction of soft spots in the subgrade or existing base will be paid for in accordance with pertinent Items or Article 4.2, “Changes in the Work.”

Asphalt used solely for curing will not be paid for directly, but will be subsidiary to this Item. Asphalt placed for curing and priming will be paid for under Item 310, “Prime Coat.”

- A. Lime.** Lime will be paid for at the unit price bid for “Lime” of one of the following types:
- Hydrated Lime (Dry),
 - Hydrated Lime (Slurry),
 - Commercial Lime Slurry,

- Quicklime (Dry), or
- Quicklime (Slurry).

This price is full compensation for materials, delivery, equipment, labor, tools, and incidentals.

Lime used for reworking a section in accordance with Section 260.4.F, "Reworking a Section," will not be paid for directly but will be subsidiary to this Item.

- B. Lime Treatment.** Lime treatment will be paid for at the unit price bid for "Lime Treatment (Existing Material)," "Lime Treatment (New Base)," or "Lime Treatment (Mixing Existing Material and New Base)," for the depth specified. No payment will be made for thickness or width exceeding that shown on the plans. This price is full compensation for shaping existing material, loosening, mixing, pulverizing, providing lime, spreading, applying lime, compacting, finishing, curing, curing materials, blading, shaping and maintaining, replacing, disposing of loosened materials, processing, hauling, preparing secondary subgrade, water, equipment, labor, tools, and incidentals.

ITEM 263

LIME TREATMENT (PLANT-MIXED)

263.1. Description. Construct a base course composed of a mixture of flexible base, hydrated lime, and water, mixed in an approved plant.

263.2. Materials. Furnish uncontaminated materials of uniform quality that meet the requirements of the plans and specifications. Notify the Engineer of proposed sources of materials and of changes to material sources. The Engineer will verify that the requirements of this Item are met before the sources can be used. The Engineer may sample and test project materials at any time before compaction. Use Tex-100-E for material definitions.

- A. Lime.** Furnish hydrated lime that meets the requirements of DMS-6350, "Lime and Lime Slurry," and DMS-6330, "Lime Sources Prequalification of Hydrated Lime and Quicklime."
- B. Flexible Base.** Furnish base material that meets the requirements of Item 247, "Flexible Base," for the type and grade shown on the plans, before the addition of lime.
- C. Water.** Furnish water free of industrial wastes and other objectionable material.

263.3 to 263.4

- D. Asphalt.** When permitted for curing purposes, furnish asphalt or emulsion that meets the requirements of Item 300, “Asphalts, Oils, and Emulsions,” as shown on the plans or as directed.
- E. Mix Design.** Using the materials proposed for the project, the Engineer will determine the target lime content and optimum moisture content necessary to produce the required stabilized mixture. The mix will be designed in accordance with Tex-121-E. The Contractor may propose a mix design developed in accordance with Tex-121-E. The Engineer will use Tex-121-E to verify the Contractor’s proposed mix design before acceptance. Reimburse the Department for subsequent mix designs or partial designs necessitated by changes in the material or requests by the Contractor. When treating existing materials, limit the amount of asphalt concrete pavement to no more than 50% of the mix unless otherwise shown on the plans or directed.

263.3. Equipment. Provide machinery, tools, and equipment necessary for proper execution of the work. Provide rollers in accordance with Item 210, “Rolling.” Provide proof rollers in accordance with Item 216, “Proof Rolling,” when required.

- A. Storage Facility.** Store hydrated lime in closed weatherproof containers.
- B. Mixing Plant.** Provide a stationary pugmill that uniformly mixes lime, water, and base material in the specified proportions. Obtain approval before providing weigh-batch or continuous mixers. Equip plants with automatic proportioning and metering devices.
- C. Spreader Equipment.** When shown on the plans, provide equipment that will spread the lime-treated mixture in a uniform layer in 1 pass. When shown on the plans, equip spreaders with electronic grade controls.

263.4. Construction. Construct each layer uniformly, free of loose or segregated areas, and with the required density and moisture content. Provide a smooth surface that conforms to the typical sections, lines, and grades shown on the plans or as directed. Complete placing, compacting, and finishing within 72 hr. after the lime is added to the base material.

Start lime operations only when the air temperature is at least 35°F and rising or is at least 40°F. The temperature will be taken in the shade and away from artificial heat. Suspend operations when the Engineer determines that weather conditions are unsuitable.

- A. Mixing.** Thoroughly mix materials in the proportions designated on the mix design, in a plant that meets the requirements of Section 263.3.B, "Mixing Plant." Mix at optimum moisture content, unless otherwise directed, until a homogeneous mixture is obtained.
- B. Placing.** Place lime-treated base on a subgrade or base prepared in accordance with details shown on the plans. Bring the prepared roadway to the moisture content directed. Haul lime-treated base to the roadway in clean trucks and begin placement immediately. Spread and shape in a uniform layer with an approved spreader. Construct individual layers to the thickness shown on the plans, the same day as delivered, unless otherwise approved. Do not place lifts exceeding a compacted depth of 8 in. unless otherwise shown on the plans. Maintain the shape of the course by blading. Correct or replace segregated areas as directed, at no additional expense to the Department.

Construct vertical joints between segmented areas of lime-treated base. The vertical face may be created by using a header or by cutting back the face to approximately vertical. Place successive base courses using the same methods as the first course. Offset construction joints by at least 6 in.

- C. Compaction.** Immediately after placing, compact the mixture using density control, unless otherwise shown on the plans. Multiple lifts are permitted when shown on the plans or approved. Bring each layer to the moisture content directed. When necessary, sprinkle the treated material in accordance with Item 204, "Sprinkling." Determine the moisture content of the mixture at the beginning and during compaction in accordance with Tex-103-E.

Begin rolling longitudinally at the sides and proceed towards the center, overlapping on successive trips by at least 1/2 the width of the roller unit. On superelevated curves, begin rolling at the low side and progress toward the high side. Offset alternate trips of the roller. Operate rollers at a speed between 2 and 6 MPH, as directed.

Rework, recompact, and refinish material that fails to meet or that loses required moisture, density, stability, or finish before the next course is placed or the project is accepted. Continue work until specification requirements are met. Rework in accordance with Section 263.4.D, "Reworking a Section." Perform the work at no additional expense to the Department.

- 1. Ordinary Compaction.** Roll with approved compaction equipment as directed. Correct irregularities, depressions, and

263.4 to 263.4

weak spots immediately by scarifying the areas affected, adding or removing treated material as required, reshaping, and recompacting.

2. **Density Control.** Compact the bottom course to at least 95% of the maximum density determined in accordance with Tex-121-E, unless otherwise shown on the plans. Compact subsequent courses treated under this Item to at least 98% of the maximum density determined in accordance with Tex-121-E, unless otherwise shown on the plans.

The Engineer will determine roadway density of completed sections in accordance with Tex-115-E. The Engineer may accept the section if no more than 1 of the 5 most recent density tests is below the specified density and the failing test is no more than 3 pcf below the specified density.

- D. **Reworking a Section.** When a section is reworked within 72 hr. after completion of compaction, rework the section, without adding additional lime, to provide the required density. When a section is reworked more than 72 hr. after completion of compaction, add additional lime at the rate of 25% of the percentage determined in Section 263.2.E, "Mix Design." Reworking includes loosening, adding material or removing unacceptable material if necessary, road-mixing as directed, compacting, and finishing. When density control is specified, determine the new maximum density of the reworked material in accordance with Tex-121-E, and compact to at least 95% of this density. The Contractor has the option of removing the failing material and replacing it with acceptable lime-treated mix.
- E. **Finishing.** Immediately after completing compaction of the final course, clip, skin, or tight-blade the surface of the lime-treated material with a maintainer to a depth of approximately 1/4 in. Remove loosened material and dispose of it at an approved location. Seal the clipped surface immediately by rolling with a pneumatic-tire roller until a smooth surface is attained. Add small increments of water as needed during rolling. Shape and maintain the course and surface in conformity with the typical sections, lines, and grades shown on the plans or as directed.

In areas where surfacing is to be placed, trim grade deviations greater than 1/4 in. in 16 ft. measured longitudinally or greater than 1/4 in. over the entire width of the cross-section. Remove excess material, reshape, and roll with a pneumatic-tire roller. If material is more than 1/4 in. low, correct as directed. Do not surface patch. The 72-hr. time limit

required for completion of placement, compaction, and finishing does not apply to finishing required just before applying the surface course.

- F. Curing.** Cure for at least 7 days, unless otherwise approved, by sprinkling in accordance with Item 204, "Sprinkling," or by applying an asphalt material at a rate of 0.05 to 0.20 gal. per square yard as directed. Maintain moisture during curing. Continue curing until placing another course or opening to traffic. Open to traffic as directed. Do not allow equipment on the finished course during curing except as required for sprinkling, unless otherwise approved. Apply seals or additional courses within 14 days of final compaction.

263.5. Measurement. Lime-treated base will be measured by the cubic yard, square yard, or ton, as a composite mixture of lime, flexible base, and recycled materials.

Measurement by the cubic yard in final position and by the square yard is plans quantity measurement. The quantity to be paid for is the quantity shown in the proposal unless modified by Article 9.2, "Plans Quantity Measurement." Additional measurements or calculations will be made if adjustments of quantities are required.

Measurement is further defined for payment as follows:

- A. Cubic Yard in Vehicles.** Lime-treated base will be measured by the cubic yard in vehicles as delivered on the road.
- B. Cubic Yard in Final Position.** Lime-treated base will be measured by the cubic yard in its final position. The volume of each course will be computed in-place between the original subgrade surfaces and the lines, grades, and slopes of the accepted base course as shown on the plans and calculated by the method of average end areas.
- C. Square Yard.** Lime-treated base will be measured by the square yard of surface area. The dimensions for determining the surface area are established by the dimensions shown on the plans.
- D. Ton.** Lime-treated base will be measured by the ton (dry weight) in vehicles as delivered on the road. The dry weight is determined by deducting the weight of the moisture in the material at the time of weighing from the gross weight of the material. The Engineer will determine the moisture content in the material in accordance with Tex-103-E, from samples taken at the time of weighing.

When material is measured in trucks, the weight of the material will be determined on certified scales, or the Contractor must provide a set of standard platform truck scales at a location approved by the Engineer.

263.6 to 263.6

Scales must conform to the requirements of Item 520, “Weighing and Measuring Equipment.”

263.6. Payment. The work performed and materials furnished in accordance with this Item and measured as provided under “Measurement” will be paid for at the unit price bid for “Lime Treatment (Plant Mixed),” of the flexible base type, grade, and thickness (for square yard measurement) specified. For cubic yard measurement, “In Vehicle” or “Final Position” will be specified. This price is full compensation for furnishing and disposing of materials (including lime and base); storing, mixing, hauling, placing, sprinkling, compacting, finishing, curing, and maintaining and reworking of treated base; and equipment, labor, tools, and incidentals.

Sprinkling and rolling, except proof rolling, will not be paid for directly but will be subsidiary to this Item, unless otherwise shown on the plans. When proof rolling is shown on the plans or directed by the Engineer, it will be paid for in accordance with Item 216, “Proof Rolling.”

Where subgrade or base courses are constructed under this Contract, correction of soft spots will be at the Contractor’s expense. Where subgrade or base is not constructed under this Contract, correction of soft spots will be in accordance with pertinent Items or Article 4.2, “Changes in the Work.”

Asphalt used solely for curing will not be paid for directly, but will be subsidiary to this Item. Asphalt placed for curing and priming will be paid for under Item 310, “Prime Coat.”

Removal and disposal of existing asphalt concrete pavement will be paid for in accordance with pertinent Items or Article 4.2, “Changes in the Work.”

A. Thickness Measurement for Cubic Yard In Final Position and Square Yard Payment Adjustment. Before final acceptance, the Engineer will select the locations of tests within each unit and measure the treated base depths in accordance with Tex-140-E.

1. Units for Payment Adjustment.

- a. Roadways and Shoulders.** Units for applying a payment adjustment for thickness to roadways and shoulders are defined as 1,000 linear feet of treated base in each placement width. The last unit in each placement width will be 1,000 ft. plus the fractional part of 1,000 ft. remaining. Placement width is the width between longitudinal construction joints. For widening, the placement width is the average width placed of the widened section that is deficient in thickness.

- b. Ramps and Other Areas.** Units are defined as 2,000 sq. yd. or fraction thereof for establishing an adjusted unit price for ramps, intersections, irregular sections, crossovers, entrances, partially completed units, transitions to ramps, and other areas designated by the Engineer.

2. Price Adjustments of Deficient Areas.

- a. Thickness Deficiency ≤ 1.0 in.** Table 1 will govern the price adjustment for each unit with deficient areas ≤ 1.0 in.

**Table 1
Measurements and Price Adjustment for Each Unit**

Thickness Deficiency	Minimum Number of Additional Measurements	Average Thickness Deficiency of 3 Measurements	Price Adjustment
≤ 0.5 in.	None	N/A	Full Payment
> 0.5 in.	2	≤ 0.5 in.	Full Payment
		> 0.5 in. and ≤ 0.8 in.	75% Payment
		> 0.8 in. and ≤ 1.0 in.	50% Payment
		> 1.0 in.	In accordance with Section 263.6.A.2.b.

- b. Thickness Deficiency > 1.0 in.** Remove and replace areas of treated base found deficient in thickness by more than 1.0 in., unless otherwise approved. Take exploratory measurements at 50-ft. intervals parallel to the centerline in each direction from the deficient measurement until a measurement is not deficient by more than 1.0 in. If, in the judgment of the Engineer, the area of deficient thickness should not be reworked, there will be no payment for the area left in place. The minimum limit of non-pay will be 100 ft.

- B. Excess Thickness and Width.** For cubic yard in final position and square yard measurement, no additional payment will be made for thickness or width exceeding that shown on the plans.

ITEM 265

FLY ASH OR LIME—FLY ASH TREATMENT (ROAD-MIXED)

265.1. Description. Mix and compact water, fly ash (FA) or lime and fly ash (LFA), and subgrade or base (with or without asphalt concrete pavement) in the roadway.

265.2. Materials. Furnish uncontaminated materials of uniform quality that meet the requirements of the plans and specifications. Notify the Engineer of proposed material sources and of changes in material sources. The Engineer will verify that the specification requirements are met before the sources can be used. The Engineer may sample and test project materials at any time before compaction. Use Tex-100-E for material definitions.

- A. Lime.** Furnish lime that meets the requirements of DMS-6350, “Lime and Lime Slurry,” and DMS-6330, “Lime Sources Prequalification of Hydrated Lime and Quicklime.” Use hydrated lime, commercial lime slurry, or quicklime as shown on the plans. When furnishing quicklime, provide it in bulk.
- B. Fly Ash.** Furnish fly ash that meets the requirements of DMS-4615, “Fly Ash for Soil Treatment.” Use Class CS or FS as shown on the plans.
- C. Flexible Base.** When required, furnish base material that meets the requirements of Item 247, “Flexible Base,” for the type and grade shown on the plans, before the addition of lime or fly ash.
- D. Water.** Furnish water free of industrial wastes and other objectionable matter.
- E. Asphalt.** When permitted for curing purposes, furnish asphalt or emulsion in accordance with Item 300, “Asphalts, Oils, and Emulsions,” as shown on the plans or as directed.
- F. Mix Design.** The Engineer will determine the target fly ash or lime—fly ash content and optimum moisture content in accordance with Tex-127-E or prior experience with the project materials. The Contractor may propose a mix design developed in accordance with Tex-127-E. The Engineer will use Tex-127-E to verify the Contractor’s proposed mix design before acceptance. Reimburse the Department for subsequent mix designs or partial designs necessitated by changes in the material or requests by the Contractor. When treating existing materials, limit the amount of asphalt concrete pavement to no more than 50% of the mix unless otherwise shown on the plans or directed.

265.3. Equipment. Provide machinery, tools, and equipment necessary for proper execution of the work. Provide rollers in accordance with Item 210, "Rolling." Provide proof rollers in accordance with Item 216, "Proof Rolling," when directed.

- A. Storage Facility.** Store quicklime, dry hydrated lime, and fly ash in closed, weatherproof containers.
- B. Slurry Equipment.** Use slurry tanks equipped with agitation devices to slurry hydrated lime or quicklime on the project or other approved location. The Engineer may approve other slurring methods.

Provide a pump for agitating the slurry when the distributor truck is not equipped with an agitator. Equip the distributor truck with a sampling device in accordance with Tex-600-J, Part I, when using commercial lime slurry.

- C. Pulverization Equipment.** Provide pulverization equipment that:
- cuts and pulverizes material uniformly to the proper depth with cutters that will plane to a uniform surface over the entire width of the cut,
 - provides a visible indication of the depth of cut at all times, and
 - uniformly mixes the materials.

265.4. Construction. Construct each layer uniformly, free of loose or segregated areas and with the required density and moisture content. Provide a smooth surface that conforms to the typical sections, lines, and grades shown on the plans or as directed.

- A. Preparation of Subgrade or Existing Base for Treatment.** Before treating, remove existing asphalt concrete pavement in accordance with pertinent Items and the plans or as directed. Shape existing material in accordance with applicable bid items to conform to typical sections shown on the plans and as directed.

When shown on the plans or directed, proof-roll the roadbed in accordance with Item 216, "Proof Rolling," before pulverizing or scarifying existing material. Correct soft spots as directed.

When new base material is required to be mixed with existing base, deliver, place, and spread the new material in the required amount per station. Manipulate and thoroughly mix new base with existing material to provide a uniform mixture to the specified depth before the addition of lime or fly ash.

- B. Pulverization.** Pulverize or scarify existing material after shaping so that 100% passes a 2-1/2-in. sieve. If the material cannot be uniformly

265.4 to 265.4

processed to the required depth in a single pass, excavate and windrow the material to expose a secondary grade to achieve processing to plan depth.

- C. Application and Mixing of FA or LFA.** When treating with LFA, apply, mix, and cure lime first unless otherwise directed.

Start treatment operations only when the air temperature is at least 35°F and rising or is at least 40°F. The temperature will be taken in the shade and away from artificial heat. Suspend operations when the Engineer determines that weather conditions are unsuitable.

Minimize dust and scattering by wind. Do not apply lime or fly ash when wind conditions, in the opinion of the Engineer, cause blowing lime or fly ash to become dangerous to traffic or objectionable to adjacent property owners.

During the interval between application and mixing, sections treated with hydrated lime or fly ash that have been exposed to the open air for a period of 6 hr. or more, or that experience excessive loss due to washing or blowing, will not be accepted for payment.

After mixing and required curing, the Engineer will sample the mixture at roadway moisture and test in accordance with Tex-101-E, Part III, to determine compliance with the gradation requirements in Table 1.

Table 1
Gradation Requirements (Minimum % Passing)

Sieve	Base	Subgrade
1-3/4 in.	100	100
3/4 in.	85	85
No. 4	—	60

- 1. Application of Lime.** Uniformly apply lime using dry or slurry placement as shown on the plans or as directed. Add lime at the percentage determined in Section 265.2.F, “Mix Design.” Apply lime only on an area where mixing can be completed during the same working day. *Use of quicklime can be dangerous. Inform users of the recommended precautions for handling and storage.*
 - a. Dry Placement.** Before applying lime, bring the prepared roadway to approximately optimum moisture content. When necessary, sprinkle in accordance with Item 204, “Sprinkling.” Distribute the required quantity of hydrated lime or pebble-grade quicklime with approved equipment. Only hydrated

lime may be distributed by bag. Do not use a motor grader to spread hydrated lime.

- b. Slurry Placement.** Provide slurry free of objectionable materials, at or above the approved minimum dry solids content, and with a uniform consistency that will allow ease of handling and uniform application. Deliver commercial lime slurry to the jobsite or prepare lime slurry at the jobsite or other approved location by using hydrated lime or quicklime, as specified.

Distribute slurry uniformly by making successive passes over a measured section of roadway until the specified lime content is reached. Uniformly spread the residue from quicklime slurry over the length of the roadway being processed unless otherwise directed.

- 2. Mixing of Lime.** Begin mixing within 6 hr. of lime application. Thoroughly mix the material and lime using approved equipment. Allow the mixture to mellow for 1 to 4 days as directed. When pebble-grade quicklime is used, allow the mixture to mellow for 2 to 4 days as directed. Sprinkle the treated materials during the mixing and mellowing operation, as directed, to achieve adequate hydration and proper moisture content. After mellowing, resume mixing until a homogeneous, friable mixture is obtained.

- 3. Application of Fly Ash.** Uniformly apply fly ash in dry form unless otherwise approved. Apply at the percentage determined in Section 265.2.F, "Mix Design." Apply fly ash only on that area where the mixing and compacting operations can be completed during the same working day. Do not use a motor grader to spread fly ash.

For LFA treatment, begin fly ash application within 4 days after the lime mixing operation has been completed unless otherwise approved.

- 4. Mixing of Fly Ash.** Thoroughly dry-mix the material and fly ash using approved equipment until a loose, homogeneous mixture is obtained. Sprinkle in accordance with Item 204, "Sprinkling," as directed, to achieve adequate mixing and hydration moisture. Prevent formation of fly ash balls.

- D. Compaction.** Compact immediately after mixing the last stabilizing agent. Use density control unless otherwise shown on the plans. Complete all compaction operations within 6 hr. of fly ash application.

265.4 to 265.4

Multiple lifts are permitted when shown on the plans or approved by the Engineer. Sprinkle the treated material in accordance with Item 204, "Sprinkling," or aerate to bring each layer to the moisture content directed. Determine the moisture content of the mixture at the beginning and during compaction in accordance with Tex-103-E.

Begin rolling longitudinally at the sides and proceed towards the center, overlapping on successive trips by at least 1/2 the width of the roller unit. On superelevated curves, begin rolling at the low side and progress toward the high side. Offset alternate trips of the roller. Operate rollers at a speed between 2 to 6 MPH as directed.

Rework, recompact, and refinish material that fails to meet or that loses required moisture, density, stability, or finish before the next course is placed or the project is accepted. Continue work until specification requirements are met. Rework in accordance with Section 265.4.E, "Reworking a Section." Perform the work at no additional expense to the Department.

1. **Ordinary Compaction.** Roll with approved compaction equipment as directed. Correct irregularities, depressions, and weak spots immediately by scarifying the areas affected, adding or removing treated material as required, reshaping, and recompacting.
 2. **Density Control.** The Engineer will determine roadway density of completed sections in accordance with Tex-115-E. The Engineer may accept the section if no more than 1 of the 5 most recent density tests is below the specified density and the failing test is no more than 3 pcf below the specified density.
 - a. **Subgrade.** Compact to at least 95% of the maximum density determined in accordance with Tex-127-E unless otherwise shown on the plans.
 - b. **Base.** Compact the bottom course to at least 95% of the maximum density determined in accordance with Tex-127-E unless otherwise shown on the plans. Compact subsequent courses treated under this Item to at least 98% of the maximum density determined in accordance with Tex-127-E unless otherwise shown on the plans.
- E. Reworking a Section.** Reworking includes loosening, adding material or removing unacceptable material if necessary, mixing as directed, compacting, and finishing. The Contractor has the option of removing failing material and replacing it with acceptable material.

Add lime and fly ash when reworking LFA-treated sections, or fly ash when reworking FA-treated sections, at the rate of at least 25% of the percentage determined in Section 265.2.F, "Mix Design," as directed. When repulverization of the failing section is not achievable, remove failing material and replace with acceptable treated material.

When density control is specified, determine a new maximum density of the reworked material in accordance with Tex-127-E, and compact in accordance with Section 265.4.D.2, "Density Control." Compact as directed when ordinary compaction is specified.

- F. Finishing.** Immediately after completing compaction of the final course, clip, skin, or tight-blade the surface with a maintainer or subgrade trimmer to a depth of approximately 1/4 in. Remove loosened material and dispose of it at an approved location. Seal the clipped surface immediately by rolling with a pneumatic tire roller until a smooth surface is attained. When finishing treated base, use a steel wheel roller before rolling with the pneumatic tire roller. Add small increments of water as needed during rolling. Shape and maintain the course and surface in conformity with the typical sections, lines, and grades. Complete finishing operations within 2 hr. after final compaction.

Finished grade tolerances for subgrade will be in accordance with Section 132.3.F.1, "Grade Tolerances." Finished grade tolerances for base will be in accordance with Section 247.4.D, "Finishing."

- G. Curing.** Cure by maintaining in a thorough and continuously moist condition by sprinkling in accordance with Item 204, "Sprinkling." When permitted, cure with an asphalt material applied at a rate of 0.05 to 0.20 gal. per square yard as approved. Do not allow equipment on the finished course during curing except as required for sprinkling, unless otherwise approved.
- 1. LFA-Treated Sections.** Cure the finished section for 7 days before adding another course or opening to traffic unless otherwise directed. Apply subsequent courses within 14 calendar days of completion of final compaction of the underlying treated course unless otherwise approved.
 - 2. FA-Treated Sections.** Cure the finished section for 24 hr. before opening to traffic unless otherwise directed. Curing may be accomplished by placing material to be used in the subsequent course instead of moist-curing. Allow the treated course to dry for at least 48 hr. before applying a prime coat.

265.5. Measurement.

- A. Lime.** When lime is furnished in trucks, the weight of lime will be determined on certified scales, or the Contractor must provide a set of standard platform truck scales at a location approved by the Engineer. Scales must conform to the requirements of Item 520, “Weighing and Measuring Equipment.”

When lime is furnished in bags, each bag must indicate the manufacturer’s certified weight. Bags varying more than 5% from that weight may be rejected. The average weight of bags in any shipment, as determined by weighing 10 bags taken at random, must be at least the manufacturer’s certified weight.

1. Hydrated Lime.

- a. Dry.** Lime will be measured by the ton (dry weight).
- b. Slurry.** Lime will be measured by the ton (dry weight) of the hydrated lime used to prepare the lime slurry at the jobsite.

- 2. Commercial Lime Slurry.** Lime slurry will be measured by the ton (dry weight) as calculated from the minimum percent dry solids content of the slurry, multiplied by the weight of the slurry in tons delivered.

3. Quicklime.

- a. Dry.** Lime will be measured by the ton (dry weight).
- b. Slurry.** Lime slurry will be measured by the ton (dry weight) of the quicklime used to prepare the slurry, multiplied by a conversion factor of 1.28 to give the quantity of equivalent hydrated lime, which will be the basis of payment.

- B. Fly Ash.** Fly ash will be measured by the ton (dry weight). When fly ash is furnished in trucks, the weight of fly ash will be determined on certified scales, or the Contractor must provide a set of standard platform truck scales at a location approved by the Engineer. Scales must conform to the requirements of Item 520, “Weighing and Measuring Equipment.”

When fly ash is furnished in bags, each bag must indicate the manufacturer’s certified weight. Bags varying more than 5% from that weight may be rejected. The average weight of bags in any shipment, as determined by weighing 10 bags taken at random, must be at least the manufacturer’s certified weight.

- C. FA and LFA Treatment.** FA and LFA treatment will be measured by the square yard of surface area. The dimensions for determining the

surface area are established by the widths shown on the plans and the lengths measured at placement.

265.6. Payment. The work performed and materials furnished in accordance with this Item and measured as provided under “Measurement” will be paid in accordance with Section 265.6.A, “Lime”; Section 265.6.B, “Fly Ash”; or Section 265.6.C, “FA and LFA Treatment.”

Furnishing and delivering new base will be paid for in accordance with Section 247.6.B, “Flexible Base (Roadway Delivery).” Mixing, spreading, blading, shaping, compacting, and finishing new or existing base material will be paid for under Section 265.6.C, “FA and LFA Treatment.” Removal and disposal of existing asphalt concrete pavement will be paid for in accordance with pertinent Items or Article 4.2, “Changes in the Work.”

Asphalt used solely for curing will not be paid for directly, but will be subsidiary to this Item. Asphalt placed for curing and priming will be paid for under Item 310, “Prime Coat.”

Lime and fly ash used for reworking a section in accordance with Section 265.4.E, “Reworking a Section,” will not be paid for directly but will be subsidiary to this Item.

Sprinkling and rolling, except proof rolling, will not be paid for directly but will be subsidiary to this Item unless otherwise shown on the plans. When proof rolling is shown on the plans or directed by the Engineer, it will be paid for in accordance with Item 216, “Proof Rolling.”

Where subgrade is constructed under this Contract, correction of soft spots in the subgrade or existing base will be at the Contractor’s expense. Where subgrade is not constructed under this Contract, correction of soft spots in the subgrade or existing base will be in accordance with pertinent Items or Article 4.2, “Changes in the Work.”

- A. Lime.** Lime will be paid for at the unit price bid for "Lime" of the specified type (Hydrated (Dry), Hydrated (Slurry), Commercial Lime Slurry, Quicklime (Dry), Quicklime (Slurry)). This price is full compensation for furnishing lime.
- B. Fly Ash.** Fly ash will be paid for at the unit price bid for “Fly Ash” of the type specified. This price is full compensation for furnishing fly ash.
- C. FA and LFA Treatment.** FA and LFA treatment will be paid for at the unit price bid for “LFA Treated Subgrade,” “FA Treated Subgrade,” “LFA Treatment for Base Courses (Existing Base),” “FA Treatment for Base Courses (Existing Base),” “LFA Treatment for Base Courses

275.1 to 275.2

(New Base),” “FA Treatment for Base Courses (New Base),” “LFA Treatment for Base Courses (New and Existing Base),” and “FA Treatment for Base Courses (New and Existing Base),” for the depth specified. No payment will be made for thickness or width exceeding that shown on the plans. This price is full compensation for shaping existing material, loosening, mixing, pulverizing, spreading, applying lime and fly ash, compacting, finishing, curing including curing materials, water, drying, blading, shaping and maintaining, replacing, disposing of loosened materials, processing, hauling, reworking if required, preparing secondary subgrade, equipment, labor, tools, and incidentals.

ITEM 275

CEMENT TREATMENT (ROAD-MIXED)

275.1. Description. Mix and compact cement, water, and subgrade or base (with or without asphalt concrete pavement) in the roadway.

275.2. Materials. Furnish uncontaminated materials of uniform quality that meet the requirements of the plans and specifications. Notify the Engineer of the proposed material sources and of changes to material sources. The Engineer will verify that the specification requirements are met before the sources can be used. The Engineer may sample and test project materials at any time before compaction. Use Tex-100-E for material definitions.

- A. Cement.** Furnish hydraulic cement that meets the requirements of DMS-4600, “Hydraulic Cement,” and the Department’s Hydraulic Cement Quality Monitoring Program (HCQMP). Sources not on the HCQMP will require testing and approval before use.
- B. Flexible Base.** Furnish base material that meets the requirements of Item 247, “Flexible Base,” for the type and grade shown on the plans, before the addition of cement.
- C. Water.** Furnish water free of industrial waste and other objectionable material.
- D. Asphalt.** When permitted for curing purposes, furnish asphalt or emulsion that meets the requirements of Item 300, “Asphalts, Oils, and Emulsions,” as shown on the plans or directed.
- E. Mix Design.** The Engineer will determine the target cement content and optimum moisture content to produce a stabilized mixture that meets the strength requirements shown on the plans. The mix will be

designed in accordance with Tex-120-E or will be based on prior experience with the project materials. The Contractor may propose a mix design developed in accordance with Tex-120-E. The Engineer will use Tex-120-E to verify the Contractor's proposed mix design before acceptance. Reimburse the Department for subsequent mix designs or partial designs necessitated by changes in the material or requests by the Contractor. When treating existing materials, limit the amount of asphalt concrete pavement to no more than 50% of the mix unless otherwise shown on the plans or directed.

275.3. Equipment. Provide machinery, tools, and equipment necessary for proper execution of the work. Provide rollers in accordance with Item 210, "Rolling." Provide proof rollers in accordance with Item 216, "Proof Rolling," when required.

- A. Cement Storage Facility.** Store cement in closed, weatherproof containers.
- B. Cement Slurry Equipment.** Use slurry tanks equipped with agitation devices to slurry cement on the project or other approved location. The Engineer may approve other slurring methods. Provide a pump for agitating the slurry when the distributor truck is not equipped with an agitator. Equip the distributor truck with an approved sampling device.
- C. Pulverization Equipment.** Provide pulverization equipment that:
 - cuts and pulverizes material uniformly to the proper depth with cutters that will plane to a uniform surface over the entire width of the cut,
 - provides a visible indication of the depth of cut at all times, and
 - uniformly mixes the materials.

275.4. Construction. Construct each layer uniformly, free of loose or segregated areas and with the required density and moisture content. Provide a smooth surface that conforms to the typical sections, lines, and grades shown on the plans or as directed.

- A. Preparation of Subgrade or Existing Base for Treatment.** Before treating, remove existing asphalt concrete pavement in accordance with pertinent Items and the plans or as directed. Shape existing material in accordance with applicable bid items to conform to the typical sections shown on the plans and as directed.

When shown on the plans or directed, proof roll the roadbed in accordance with Item 216, "Proof Rolling," before pulverizing or scarifying existing material. Correct soft spots as directed.

275.4 to 275.4

When new base is required to be mixed with existing base, deliver, place, and spread the new material in the required amount per station. Manipulate and thoroughly mix new base with existing material to provide a uniform mixture to the specified depth before shaping.

- B. Pulverization.** Pulverize or scarify existing material after shaping so that 100% passes a 2-1/2-in. sieve. If the material cannot be uniformly processed to the required depth in a single pass, excavate and windrow the material to expose a secondary grade to achieve processing to plan depth.
- C. Application of Cement.** Uniformly apply cement using dry placement unless otherwise shown on the plans. Add cement at the percentage determined in Section 275.2.E, "Mix Design." Apply cement only on an area where mixing, compacting, and finishing can be completed during the same working day.

Start cement application only when the air temperature is at least 35°F and rising or is at least 40°F. The temperature will be taken in the shade and away from artificial heat. Suspend application when the Engineer determines that weather conditions are unsuitable.

- 1. Dry Placement.** Before applying cement, bring the prepared roadway to approximately optimum moisture content. When necessary, sprinkle in accordance with Item 204, "Sprinkling." Distribute the required quantity of dry cement with approved equipment. Minimize dust and scattering of cement by wind. Do not apply cement when wind conditions, in the opinion of the Engineer, cause blowing cement to become dangerous to traffic or objectionable to adjacent property owners.
 - 2. Slurry Placement.** Mix the required quantity of cement with water, as approved. Provide slurry free of objectionable materials and with a uniform consistency that can be easily applied. Agitate the slurry continuously. Apply slurry within 2 hours of adding water and when the roadway is at a moisture content drier than optimum. Distribute slurry uniformly by making successive passes over a measured section of the roadway until the specified cement content is reached.
- D. Mixing.** Thoroughly mix the material and cement using approved equipment. Mix until a homogeneous mixture is obtained. Sprinkle the treated materials during the mixing operation, as directed, to maintain optimum mixing moisture. Spread and shape the completed mixture in a uniform layer.

After mixing, the Engineer will sample the mixture at roadway moisture and test in accordance with Tex-101-E, Part III, to determine compliance with the gradation requirements in Table 1.

Table 1
Gradation Requirements Minimum % Passing

Sieve Size	Base	Subgrade
1-3/4 in.	100	100
3/4 in.	85	85
No. 4	—	60

- E. Compaction.** Compact the mixture in one lift using density control unless otherwise shown on the plans. Complete compaction within 2 hours after the application of cement.

Sprinkle or aerate the treated material in accordance with Item 204, “Sprinkling,” to adjust the moisture content during compaction so that it is within 2.0 percentage points of optimum as determined by Tex-120-E. Determine the moisture content of the mixture at the beginning and during compaction in accordance with Tex-103-E. Adjust operations as required.

Begin rolling longitudinally at the sides and proceed towards the center, overlapping on successive trips by at least one-half the width of the roller unit. On superelevated curves, begin rolling at the low side and progress toward the high side. Offset alternate trips of the roller. Operate rollers at a speed between 2 and 6 MPH, as directed.

Remove areas that lose required stability, compaction, or finish. Replace with cement-treated mixture at the Contractor’s expense.

1. **Ordinary Compaction.** Roll with approved compaction equipment, as directed. Correct irregularities, depressions, and weak spots immediately by scarifying the areas affected, adding or removing treated material as required, reshaping, and recompacting.
2. **Density Control.** Compact to at least 95% of the maximum density determined in accordance with Tex-120-E. The Engineer will determine roadway density in accordance with Test Method Tex-115-E and will verify strength in accordance with Tex-120-E. Remove material that does not meet density requirements. Remove areas that lose required stability, compaction, or finish. Replace with cement-treated mixture and compact and test in accordance with density control methods.

275.5 to 275.5

The Engineer may accept the section if no more than 1 of the 5 most recent density tests is below the specified density and the failing test is no more than 3 pcf below the specified density.

- F. Finishing.** Immediately after completing compaction, clip, skin, or tight-blade the surface of the cement treated material with a maintainer or subgrade trimmer to a depth of approximately 1/4 in. Remove loosened material and dispose of it at an approved location. Roll the clipped surface immediately with a pneumatic-tire roller until a smooth surface is attained. Add small increments of water as needed during rolling. Shape and maintain the course and surface in conformity with the typical sections, lines and grades shown on the plans or as directed.

Finish grade of constructed subgrade in accordance with Section 132.3.F.1, "Grade Tolerances." Finish grade of constructed base in accordance with Section 247.4.D, "Finishing." Do not surface patch.

- G. Curing.** Cure for at least 3 days by sprinkling in accordance with Item 204, "Sprinkling," or by applying an asphalt material at the rate of 0.05 to 0.20 gal. per square yard, as shown on the plans or directed. Maintain the moisture content during curing at no lower than 2 percentage points below optimum. Do not allow equipment on the finished course during curing except as required for sprinkling, unless otherwise approved. Continue curing until placing another course or opening the finished section to traffic.

275.5. Measurement.

- A. Cement.** Cement will be measured by the ton (dry weight). When cement is furnished in trucks, the weight of cement will be determined on certified scales, or the Contractor must provide a set of standard platform truck scales at a location approved by the Engineer. Scales must conform to the requirements of Item 520, "Weighing and Measuring Equipment."

When cement is furnished in bags, indicate the manufacturer's certified weight. Bags varying more than 5% from that weight may be rejected. The average weight of bags in any shipment, as determined by weighing 10 bags taken at random, must be at least the manufacturer's certified weight.

Cement slurry will be measured by the ton (dry weight) of the cement used to prepare the slurry at the job site or from the minimum percent dry solids content of the slurry, multiplied by the weight of the slurry in tons delivered.

- B. Cement Treatment.** Cement treatment will be measured by the square yard of surface area. The dimensions for determining the surface area are established by the widths shown on the plans and lengths measured at placement.

275.6. Payment. The work performed and materials furnished in accordance with this Item and measured as provided under “Measurement” will be paid in accordance with Section 275.5.A, “Cement,” or Section 275.5.B, “Cement Treatment.”

Furnishing and delivering new base will be paid for in accordance with Item 247.6.B, “Flexible Base (Roadway Delivery).” Mixing, spreading, blading, shaping, compacting, and finishing new or existing base material will be paid for under Section 275.6.B, “Cement Treatment.” Removal and disposal of existing asphalt concrete pavement will be paid for in accordance with pertinent Items or Article 4.2, “Changes in the Work.”

Sprinkling and rolling, except proof-rolling, will not be paid for directly but will be subsidiary to this Item, unless otherwise shown on the plans. When proof-rolling is shown on the plans or directed by the Engineer, it will be paid for in accordance with Item 216, “Proof Rolling.”

Where subgrade is constructed under this Contract, correction of soft spots in the subgrade or existing base will be at the Contractor’s expense. Where subgrade is not constructed under this Contract, correction of soft spots in the subgrade or existing base will be in accordance with pertinent Items or Article 4.2, “Changes in the Work.”

Asphalt used solely for curing will not be paid for directly, but will be subsidiary to this Item. Asphalt placed for the purpose of curing and priming will be paid for under Item 310, “Prime Coat.”

- A. Cement.** Cement will be paid for at the unit price bid for “Cement.” This price is full compensation for materials, delivery, equipment, labor, tools, and incidentals.
- B. Cement Treatment.** Cement treatment will be paid for at the unit price bid for “Cement Treatment (Existing Material),” “Cement Treatment (New Base),” or “Cement Treatment (Mixing Existing Material and New Base),” for the depth specified. No additional payment will be made for thickness or width exceeding that shown on the plans. This price is full compensation for shaping existing material, loosening, mixing, pulverizing, providing cement, spreading, applying cement, compacting, finishing, curing, curing materials, blading, shaping and maintaining shape, replacing mixture, disposing of loosened materials,

276.1 to 276.2

processing, hauling, preparing secondary subgrade, water, equipment, labor, tools, and incidentals.

ITEM 276

CEMENT TREATMENT (PLANT-MIXED)

276.1. Description. Construct a base course composed of flexible base, hydraulic cement, and water, mixed in an approved plant.

276.2. Materials. Furnish uncontaminated materials of uniform quality that meet the requirements of the plans and specifications. Notify the Engineer of proposed sources of materials and of changes in material sources. The Engineer will verify that the specification requirements are met before the sources can be used. The Engineer may sample and test project materials at any time before compaction. Use Tex-100-E for material definitions.

- A. Cement.** Furnish hydraulic cement that meets the requirements of DMS-4600, "Hydraulic Cement," and the Department's Hydraulic Cement Quality Monitoring Program (HCQMP). Sources not on the HCQMP will require testing and approval before use.
- B. Flexible Base.** Furnish base material that meets the requirements of Item 247, "Flexible Base," for the type and grade shown on the plans, before the addition of cement.
- C. Water.** Furnish water that is free of industrial waste and other objectionable material.
- D. Asphalt.** When permitted for curing purposes, furnish asphalt or emulsion that meets the requirements of Item 300, "Asphalts, Oils, and Emulsions," as shown on the plans or as directed.
- E. Mix Design.** Using the materials proposed for the project, the Engineer will determine the target cement content and optimum moisture content necessary to produce a stabilized mixture meeting the strength requirements shown in Table 1 for the class specified on the plans. The mix will be designed in accordance with Tex-120-E. The Contractor may propose a mix design developed in accordance with Tex-120-E. The Engineer will use Tex-120-E to verify the Contractor's proposed mix design before acceptance. The Engineer may use project materials sampled from the plant or the quarry, and sampled by the Engineer or the Contractor, as determined by the Engineer. Limit the amount of asphalt concrete pavement to no more than 50% of the mix unless otherwise shown on the plans or directed.

Table 1
Strength Requirements

Class	7-Day Unconfined Compressive Strength, Min. psi
L	300
M	175
N	As shown on the plans

276.3. Equipment. Provide machinery, tools, and equipment necessary for proper execution of the work. Provide rollers in accordance with Item 210, "Rolling." Provide proof rollers in accordance with Item 216, "Proof Rolling," when required.

- A. Cement Storage Facility.** Store cement in closed, weatherproof containers.
- B. Mixing Plant.** Provide a stationary pugmill, weigh-batch, or continuous mixing plant as approved. Equip plants with automatic proportioning and metering devices that produce a uniform mixture of base material, cement, and water in the specified proportions.
- C. Spreader Equipment.** When shown on the plans, provide equipment that will spread the cement-treated mixture in a uniform layer in 1 pass. When shown on the plans, equip spreaders with electronic grade controls.

276.4. Construction. Construct each layer uniformly, free of loose or segregated areas and with the required density and moisture content. Provide a smooth surface that conforms to the typical sections, lines, and grades shown on the plans or established by the Engineer. Start placement operations only when the air temperature is at least 35°F and rising or is at least 40°F. The temperature will be taken in the shade and away from artificial heat. Suspend operations when the Engineer determines that weather conditions are unsuitable.

- A. Mixing.** Thoroughly mix materials in the proportions designated on the mix design, in a mixing plant that meets the requirements of Section 276.3.B, "Mixing Plant." Mix at optimum moisture content, unless otherwise directed, until a homogeneous mixture is obtained. Do not add water to the mixture after mixing is completed unless directed.
- B. Placing.** Place the cement-treated base on a subgrade or base prepared in accordance with details shown on the plans. Bring the prepared roadway to the moisture content directed. Haul cement-treated base to the roadway in clean trucks and begin placement immediately. Place cement-treated base only on an area where compacting and finishing

276.4 to 276.4

can be completed during the same working day. Spread and shape in a uniform layer with an approved spreader. Construct individual layers to the thickness shown on the plans. Maintain the shape of the course by blading. Correct or replace segregated areas as directed, at no additional expense to the Department.

Construct vertical joints between new cement-treated base and cement-treated base that has been in place 4 hr. or longer. The vertical face may be created by using a header or by cutting back the face to approximately vertical. Place successive base courses using the same methods as the first course. Offset construction joints by at least 6 in.

- C. Compaction.** Compact each layer immediately after placing. Complete compaction within 2 hr. after plant-mixing water with dry material. When multiple lifts are permitted, complete compaction of the final lift within 5 hr. after adding water to the treated base used in the first lift.

Moisture content in the mixture at the plant may be adjusted so that during compaction it is within 2.0 percentage points of optimum as determined by Tex-120-E. Determine the moisture content in the mixture at the beginning of and during compaction in accordance with Tex-103-E. Maintain uniform moisture content by sprinkling the treated material in accordance with Item 204, "Sprinkling."

Begin rolling longitudinally at the sides and proceed towards the center, overlapping on successive trips by at least 1/2 the width of the roller unit. On superelevated curves, begin rolling at the low side and progress toward the high side. Offset alternate trips of the roller. Operate rollers at a speed between 2 and 6 MPH, as directed.

Compact to at least 95% of maximum density as determined in accordance with Tex-120-E. The Engineer will determine roadway density in accordance with Tex-115-E and will verify strength in accordance with Tex-120-E. Remove material that does not meet density requirements. Remove areas that lose required stability, compaction, or finish. Replace with cement-treated mixture and compact and test in accordance with density control methods.

The Engineer may accept the section if no more than 1 of the 5 most recent density tests is below the specified density and the failing test is no more than 3 pcf below the specified density.

- D. Finishing.** Immediately after completing compaction, clip, skin, or tight blade the surface of the cement-treated material with a maintainer or subgrade trimmer to a depth of approximately 1/4 in. Remove loosened material and dispose of at an approved location. Roll the

clipped surface immediately with a pneumatic tire roller until a smooth surface is attained. Add small increments of water as needed during rolling. Shape and maintain the course and surface in conformity with the typical sections, lines, and grades shown on the plans or as directed.

In areas where surfacing is to be placed, trim grade deviations greater than 1/4 in. in 16 ft. measured longitudinally or greater than 1/4 in. over the entire width of the cross-section. Remove excess material, reshape, and then roll with a pneumatic tire roller. If material is more than 1/4 in. low, correct as directed. Do not surface patch.

- E. Curing.** Cure for at least 3 days by sprinkling in accordance with Item 204, "Sprinkling," or by applying an asphalt material at the rate of 0.05 to 0.20 gal. per square yard, as shown on the plans or directed. Maintain the moisture content during curing at no lower than 2 percentage points below optimum. Do not allow equipment on the finished course during curing except as required for sprinkling, unless otherwise approved. Continue curing until placing another course or opening the finished section to traffic.

276.5. Measurement. Cement-treated base will be measured by the ton, cubic yard, or square yard as a composite mixture of cement, flexible base, and recycled materials.

Measurement by the cubic yard in final position and square yard is a plans quantity measurement. The quantity to be paid for is the quantity shown in the proposal unless modified by Article 9.2, "Plans Quantity Measurement." Additional measurements or calculations will be made if adjustments of quantities are required.

Measurement is further defined for payment as follows:

- A. Cubic Yard in Vehicles.** Cement-treated base will be measured by the cubic yard in vehicles as delivered on the road.
- B. Cubic Yard in Final Position.** Cement-treated base will be measured by the cubic yard in its completed and accepted final position. The volume of each course will be computed in-place between the original subgrade surfaces and the lines, grades, and slopes of the accepted base course as shown on the plans, and calculated by the method of average end areas.
- C. Square Yard.** Cement-treated base will be measured by the square yard of surface area. The dimensions for determining the surface area are established by the dimensions shown on the plans.

276.6 to 276.6

- D. Ton.** Cement-treated base will be measured by the ton (dry weight) in vehicles as delivered on the road. The dry weight is determined by deducting the weight of the moisture in the material at the time of weighing from the gross weight of the material. The Engineer will determine the moisture content in the material in accordance with Tex-103-E from samples taken at the time of weighing.

When material is measured in trucks, the weight of the material will be determined on certified scales, or the Contractor must provide a set of standard platform truck scales at a location approved by the Engineer. Scales must conform to the requirements of Item 520, "Weighing and Measuring Equipment."

276.6. Payment. The work performed and materials furnished in accordance with this Item and measured as provided under "Measurement" will be paid for at the unit price bid for "Cement Treatment (Plant Mix)" of the class (strength), flexible base type, grade, and thickness (for square yard measurement) specified. For cubic yard measurement, "In Vehicle" or "In Final Position" will be specified. This price is full compensation for furnishing and disposing of materials (including cement and base); storing, mixing, hauling, placing, sprinkling, compacting, finishing, curing, and maintaining and reworking treated base; and equipment, labor, tools, and incidentals.

Sprinkling and rolling, except proof rolling, will not be paid for directly but will be subsidiary to this Item, unless otherwise shown on the plans. When proof rolling is shown on the plans or directed by the Engineer, it will be paid for in accordance with Item 216, "Proof Rolling."

Where subgrade or base courses are constructed under this Contract, correction of soft spots will be at the Contractor's expense. Where subgrade or base is not constructed under this Contract, correction of soft spots will be paid for in accordance with pertinent Items and Article 4.2, "Changes in the Work."

Asphalt used solely for curing will not be paid for directly but will be subsidiary to this Item. Asphalt placed for curing and priming will be paid for under Item 310, "Prime Coat."

Removal and disposal of existing asphalt concrete pavement will be paid for in accordance with pertinent Items or Article 4.2, "Changes in the Work."

- A. Thickness Measurement for Cubic Yard In Final Position and Square Yard Payment Adjustment.** Before final acceptance, the Engineer will select the locations of tests within each unit and measure the treated base depths in accordance with Tex-140-E.

1. Units for Payment Adjustment.

- a. Roadways and Shoulders.** Units for applying a payment adjustment for thickness to roadways and shoulders are defined as 1,000 linear ft. of treated base in each placement width. The last unit in each placement width will be 1,000 ft. plus the fractional part of 1,000 ft. remaining. Placement width is the width between longitudinal construction joints. For widening, the placement width is the average width placed of the widened section that is deficient in thickness.
- b. Ramps and Other Areas.** Units are defined as 2,000 sq. yd. or fraction thereof for establishing an adjusted unit price for ramps, intersections, irregular sections, crossovers, entrances, partially completed units, transitions to ramps, and other areas designated by the Engineer.

2. Price Adjustments of Deficient Areas.

- a. Thickness Deficiency ≤ 1.0 in.** Table 2 will govern the price adjustment for each unit with deficient areas ≤ 1.0 in.

Table 2
Measurements and Price Adjustment for Each Unit

Thickness Deficiency	Additional Measurements	Average Thickness Deficiency of 3 Measurements		Price Adjustment
≤ 0.5 in.	None	N/A		Full Payment
> 0.5 in.	2	≤ 0.5 in.		Full Payment
		> 0.5 in.	≤ 0.8 in.	75% Payment
		> 0.8 in.	≤ 1.0 in.	50% Payment
		> 1.0 in.		In accordance with Section 276.6.A.2.b.

- b. Thickness Deficiency ≥ 1.0 in.** Remove and replace areas of treated base found deficient in thickness by more than 1.0 in., unless otherwise approved. Take exploratory measurements at 50-ft. intervals parallel to the centerline in each direction from the deficient measurement until a measurement is not deficient by more than 1.0 in. The minimum limit of non-pay will be 100 ft.

292.1 to 292.2

- B. Excess Thickness and Width.** For cubic yard in final position and square yard measurement, no additional payment will be made for thickness or width exceeding that shown on the plans.

ITEM 292

ASPHALT TREATMENT (PLANT-MIXED)

292.1. Description. Construct a base or foundation course composed of a compacted mixture of aggregate and asphalt binder mixed hot in a mixing plant.

292.2. Materials. Furnish uncontaminated materials of uniform quality that meet the requirements of the plans and specifications. Notify the Engineer of the proposed material sources and of changes to material sources. When a source change occurs, the Engineer will verify that the specification requirements are met and may require a new laboratory mixture design. Use Tex-100-E for material definitions.

- A. Aggregate.** Furnish natural aggregates or crushed concrete unless otherwise shown on the plans. When shown on the plans, other recycled materials, including reclaimed asphalt concrete pavement (RAP), are allowed up to the maximum percentage shown on the plans. Stockpile aggregates for each source and type separately. Do not add material to an approved stockpile unless approved by the Engineer.

Furnish aggregates that conform to the requirements shown in Table 1 and specified in this Section unless otherwise shown on the plans. Each source must meet the requirements of Table 1. The Engineer may allow testing of the proposed combined aggregates, rather than each source, to meet Table 1 requirements.

Table 1
Aggregate Quality Requirements

Property	Test Method	Specification Requirement
Wet ball mill, % max	Tex-116-E	50
Max increase, % passing #40		20
Los Angeles abrasion ¹ , % max	Tex-410-A	50
Liquid limit, max	Tex-104-E	40
Plasticity index, max	Tex-106-E	10
Sand equivalent, % min	Tex-203-F	40
Decantation ² , % max	Tex-406-A	5.0
Crushed faces, % min	Tex-460-A	60

1. Use only when shown on the plans, instead of wet ball mill test.

2. Required only for RAP stockpiles and recycled aggregates when more than 30% RAP is allowed.

B. Recycled Materials. The use of recycled materials is allowed only when shown on the plans. Crushed concrete, RAP (except for Department furnished RAP), and other recycled materials must meet the requirements of this Article. Request approval to blend 2 or more sources of recycled materials.

1. Limits on Percentage. When RAP is allowed by the plans, use no more than 30% unless otherwise shown on the plans. The percentage limitations for other recycled materials will be as shown on the plans.

2. Recycled Material (Including Crushed Concrete) Requirements.

a. Contractor Furnished Recycled Materials. When the Contractor furnishes the recycled materials, including crushed concrete, the final product will be subject to the requirements of this Article and Table 2 for the grade specified. Certify compliance with DMS-11000, "Evaluating and Using Nonhazardous Recyclable Materials Guidelines," for Contractor-furnished recycled materials. In addition, recycled materials must be free from reinforcing steel and other objectionable material and have at most 1.5% deleterious material when tested in accordance with Tex-413-A. The unblended recycled materials (crushed concrete and RAP)

must not exceed the decantation shown in Table 1. Test RAP without removing the asphalt. Do not use RAP that is contaminated by dirt or other objectionable material. Crushed concrete must be managed in a way to provide for uniform quality. The Engineer may require separate dedicated stockpiles in order to verify compliance.

When more than 30% Contractor-owned recycled materials is allowed and used, the individual materials are subject to the requirements of Table 1.

b. Department Furnished Required Recycled Materials.

When the Department furnishes and requires the use of recycled materials, unless otherwise shown on the plans:

- Department required recycled material will not be subject to the requirements in Table 1,
- Contractor furnished materials are subject to the requirements in Table 1 and this Item, and
- the final product, blended or unblended, will be subject to the requirements in Table 2.

Crush Department-furnished RAP so that 100% passes the 2 in. sieve. The Contractor is responsible for uniformly blending to meet the percentage required.

c. Department Furnished and Allowed Recycled Materials.

When the Department furnishes and allows the use of recycled materials or allows the Contractor to furnish recycled materials, the final blended product is subject to the requirements of this Article, Table 2, and the plans.

- 3. Recycled Material Sources.** Department-owned recycled material is available to the Contractor only when shown on the plans. The location, approximate asphalt content, and approximate gradation will be shown on the plans for Department-owned RAP sources in a stockpile condition prior to Contract Execution. Assume that required Department-owned RAP meets Table 1 requirements. Return unused Department-owned recycled materials to the Department stockpile location designated by the Engineer unless otherwise shown on the plans.

The use of Contractor-owned recycled materials is allowed when shown on the plans. Contractor-owned surplus recycled materials remain the property of the Contractor. Remove Contractor-owned recycled materials from the project and dispose of it in accordance with federal, state, and local regulations before project acceptance.

Do not intermingle Contractor-owned recycled material with Department-owned recycled material unless approved by the Engineer.

- C. Asphalt Material.** Furnish the type and grade of asphalt binder specified on the plans. Provide asphalt binder that meets requirements of Item 300, “Asphalts, Oils and Emulsions.” When more than 30% RAP is allowed and used, ensure that the new binder and recovered binder from the RAP, when blended proportionally, meet the PG binder designation shown on the plans.
- D. Tack Coat.** Unless otherwise shown on the plans or approved, furnish CSS-1H, SS-1H, or a PG binder with a minimum high temperature grade of PG 58 for tack coat binder in accordance with Item 300, “Asphalts, Oils, and Emulsions.”

Do not dilute emulsified asphalts at the terminal, in the field, or at any other location before use. If required, verify that emulsified asphalt proposed for use meets the minimum residual asphalt percentage specified in Item 300, “Asphalts, Oils, and Emulsions.”

The Engineer will obtain at least 1 sample of the tack coat binder per project and test to verify compliance with Item 300. The Engineer will obtain the sample from the asphalt distributor immediately before use.

- E. Additives.** When shown on the plans, use the type and rate of additive specified. Other additives that facilitate mixing or improve the quality of the mix may be allowed when approved.

If lime or a liquid antistripping agent is used, add in accordance with Item 301, “Asphalt Antistripping Agents.” Do not add lime directly into the mixing drum of any plant where lime is removed through the exhaust stream unless the plant has a baghouse or dust collection system that reintroduces the fines back into the drum.

292.3. Equipment. Provide machinery, tools, and equipment in accordance with Item 320, “Equipment for Production, Hauling, and Placement of Hot-Mixed Asphalt Materials.”

292.4. Construction. Produce, haul, place, and compact the specified mixture in accordance with the requirements of this Item.

- A. Mixture Design.** Using Tex-126-E and the materials proposed for the project, the Engineer will determine the target asphalt content required to produce a mixture meeting the requirements in Table 2 for the grade shown on the plans. The gradation of the combined aggregates will be determined in accordance with Tex-200-F, Part I. The Engineer may

accept a design from the Contractor that is performed in accordance with Tex-126-E. Reimburse the Department for subsequent mixture designs or partial designs necessitated by changes in the material or requests by the Contractor.

**Table 2
Mix Requirements**

Master Gradation Bands				
Tex-200-F, Part I, % Passing by Weight				
Sieve Size	Grade 1	Grade 2	Grade 3	Grade 4
1-3/4"		100	100	As shown on the plans
1-1/2"	100	90-100		
1"	90-100			
3/8"	45-70			
#4	30-55	25-55		
#40	15-30	15-40	15-40	
Strength Requirements				
Slow strength, psi, min. ¹	50	40	30	30 ²

1. At optimum asphalt content.
2. Unless a higher minimum strength is shown on the plans.

The mixture must contain between 3.0% and 9.0% asphalt when designed in accordance with Tex-126-E. The Engineer will evaluate the mixture for moisture susceptibility in accordance with Tex-530-C unless otherwise shown on the plans. A maximum of 10% stripping is allowed unless otherwise shown on the plans. The test sample will be retained and used to establish a baseline for comparison to production results. The Engineer may waive this test if a similar design using the same materials has proven satisfactory.

Produce a trial batch using the proposed project materials and equipment in a large enough quantity to ensure that the mixture is representative of the mixture design. The Department will verify the strength requirement in Table 2 is met. The Engineer may waive trial mixtures if similar designs have proven satisfactory.

B. Production Operations. Produce a new trial batch when the plant or plant location is changed. Take corrective action and receive approval to proceed after any production suspension for non-compliance to the specification.

- 1. Storage and Heating of Materials.** Do not heat the asphalt binder above the temperature specified in Item 300, "Asphalts, Oils and

Emulsions,” or outside the manufacturer’s recommended values. On a daily basis, provide the Engineer with the records of asphalt binder and hot mix asphalt discharge temperatures in accordance with Item 320, “Equipment for Hot-Mix Asphalt Materials.” Unless otherwise approved, do not store hot mix for more than 12 hr. or for a time period less than 12 hr. that affects the quality of the mixture.

2. **Mixing and Discharge of Materials.** Notify the Engineer of the target discharge temperature and produce the mixture within 25°F of the target. When ordinary compaction is used, the Engineer will select a target discharge temperature between 225°F and 350°F. Produce the mixture within 25°F of the target. Monitor the temperature of the material in the truck before shipping to ensure that it does not exceed 350°F. The Department will not pay for or allow placement of any mixture produced at more than 350°F.

Control the mixing time and temperature so that substantially all moisture is removed from the mixture before discharging from the plant. The Engineer may perform Tex-212-F, Part II, to verify that the mixture contains no more than 0.2% moisture by weight. The sample will be taken immediately after the mixture is discharged into the truck and tested promptly.

- C. **Hauling Operations.** Before use, clean all truck beds to ensure that the mixture will not become contaminated. When a release agent is necessary, use a release agent on the approved list maintained by the Construction Division to coat the truck bed.

- D. **Placement Operations.** Prepare the surface by removing objectionable material such as moisture, dirt, sand, leaves and other loose impediments before placing the mixture. Coordinate mixture delivery and paver speed to ensure a continuous placement operation. Suspend placement operations when, in the opinion of the Engineer, a continuous paving operation is not maintained. Place the mixture to produce a smooth, finished surface with a uniform appearance and texture that meet typical section requirements. Offset longitudinal joints of successive courses of stabilized base by at least 6 in. Place the mix adjacent to gutters and structures so that the pavement will drain properly.

1. **Weather Conditions.** Tack coat and mixture may be placed only when the roadway surface temperature is 60°F or higher unless otherwise approved. Measure the roadway surface temperature with a handheld infrared thermometer. Place tack coat or mixtures

292.4 to 292.4

only when the Engineer determines that general weather conditions and moisture conditions of the roadway surface are suitable. The Engineer may waive placement temperature requirements.

2. **Tack Coat.** Clean the surface before placing the tack coat. Unless otherwise approved, apply tack coat uniformly at a rate between 0.04 and 0.10 gal. of residual asphalt per square yard of surface area. Apply a thin uniform tack coat to all contact surfaces of curbs, structures, and joints. Prevent splattering of tack coat when placed adjacent to curbs, gutters, and structures. Roll the tack coat with a pneumatic tire roller unless otherwise directed. The Engineer may use Tex-243-F to verify that the tack coat has adequate adhesive properties. The Engineer may suspend paving operations until there is adequate adhesion. The Engineer may waive the requirement to place tack coat.
3. **Lay-Down Operations.** Dump and spread the asphalt mixture on the approved prepared surface with a spreading and finishing machine. Place the material without tearing, shoving, gouging, or segregating the mixture.

Do not jar or bounce the finishing machine when loading it. Obtain the required lines and grades without hand finishing. The Engineer may authorize hand finishing when the mixture is:

- placed in a narrow strip along the edge of existing pavement,
- used to level small areas, or
- placed in small irregular areas where the use of a finishing machine is not practical.

Leveling courses and other areas may be spread with a motor grader when shown on the plans or approved.

When hot mix is placed in windrows, operate windrow pick-up equipment so that substantially all the mixture deposited on the roadbed is picked up and loaded into the spreading and finishing machine.

Adjust the hopper flow gates of the spreading and finishing machine to provide an adequate and consistent flow of material. Operate the augers at least 85% of the time. Keep the augers one-half to three-quarters full of mixture. Maintain an adequate flow of material to the center of the paver for the full width of the mat.

Immediately take appropriate corrective action if surface irregularities including but not limited to segregation, rutting, raveling, flushing, fat spots, mat slippage, color, texture, roller

marks, tears, gouges, or streaks are detected. Continue placement for no more than 1 day of production while appropriate action is taken. If no appropriate corrective action is taken or if the problem still exists after 1 day, suspend paving until the Engineer approves further production.

- E. Compaction.** Uniformly compact the pavement to the density requirements of this Item. Use the procedure described in Tex-207-F, Part IV, to establish the rolling pattern. Do not use pneumatic tire rollers if excessive pickup of fines by roller tires occurs.

When using three-wheel, tandem, or vibratory rollers, first roll the joint with the adjacent pavement. Continue rolling longitudinally at the sides, proceeding toward the center of the pavement, and overlap successive trips by at least one foot unless otherwise directed. Make alternate trips of the roller slightly different in length. Begin rolling of super-elevated curves at the low side and proceed toward the high side, unless otherwise directed.

When operating vibratory rollers:

- do not operate in vibrating mode when stationary;
- do not operate in vibrating mode when changing directions;
- do not operate in vibrating mode on mats with a plan depth of less than 1-1/2 in.;
- do not allow the roller to stand on pavement that has not been fully compacted;
- do not operate when in contact with the compacted, finished pavement structure layer;
- in case of over-vibration resulting in disruption of the compacted material, rework and recompact or replace the damaged material at the Contractor's expense;
- roll at a speed producing at least 10 blows per foot unless otherwise directed;
- keep the drums moist with water without using excess water; and
- do not drop diesel, gasoline, oil, grease, or other foreign matter on the pavement.

Where specific air void requirements are waived, furnish and operate compaction equipment as approved. Use lightly oiled tamps to thoroughly compact the edges of the pavement along curbs, headers, and similar structures and in locations that will not permit thorough compaction with rollers. The Engineer may require rolling with a trench roller on widened areas, in trenches, and in other limited areas.

292.4 to 292.4

In-place compaction control is required for all mixtures. Complete all rolling for compaction before the mixture temperature drops below 175°F. Unless otherwise shown on the plans, use density control.

1. **Density Control.** Determine the number and type of rollers needed to obtain the required density. Operate the rollers in accordance with the requirements of this specification and as approved.

Place and compact material to the minimum density required as determined by Tex-126-E or as shown on the plans. The Engineer will determine laboratory-molded density in accordance with Tex-126-E from material sampled at the plant. Actual in-place density will be determined in accordance with Tex-126-E unless otherwise directed. Unless otherwise shown on the plans, obtain required roadway specimens as directed. The Engineer will measure air voids in accordance with Tex-207-F. When a satisfactory correlation to results obtained in accordance with Tex-126-E is shown, other methods of determining in-place compaction may be used.

If in-place density is more than 1.0 percentage point below minimum density, cease production immediately. If in-place density is between 0.1 and 1.0 percentage points below minimum density, investigate the causes and make the necessary corrections. If minimum density is not obtained within one full day of operation, cease production.

Resume production after placing a test section of one lane width and a maximum 0.2 miles long that demonstrates that minimum density can be obtained. Repeat this procedure until producing a test section that meets minimum density requirements. Place no more than 2 test sections per day. Increasing the asphalt content of the mixture to increase in-place density is allowed by approval only.

2. **Ordinary Compaction** When ordinary compaction is required by the plans, furnish one three-wheel roller, one pneumatic tire roller, and one tandem roller, as directed, for each compaction operation. The Engineer may waive the use of the tandem roller when the surface is adequately smooth and further steel wheel rolling is shown to be ineffective. The Engineer may allow a vibratory roller to be substituted for the three-wheel roller, the tandem roller, or both. Use at least one pneumatic tire roller. Pneumatic tire rollers will provide a minimum of 80 psi ground contact pressure when used for compaction and a minimum of 55 psi ground contact

pressure when used for kneading and sealing the surface. Provide additional rollers as directed.

Establish rolling patterns in accordance with Tex-207-F, Part IV, unless otherwise directed. Follow the selected rolling pattern unless changes in mixture or placement conditions that affect compaction occur. When changes occur, establish a new rolling pattern.

F. Sampling and Testing.

1. Production Sampling.

- a. **Mixture Sampling.** The Engineer will obtain mixture samples in accordance with Tex-222-F.
- b. **Asphalt Binder Sampling.** The Engineer will obtain at least one 1-quart sample of the asphalt binder used during the project, labeled with date and time, sampled from a port located immediately upstream from the mixing drum or pug mill. The sample will be taken in accordance with Tex-500-C, Part II.

2. Production Testing. The Engineer will perform production tests.

- a. **Operational Tolerances.** The Engineer will determine compliance with operational tolerances. The gradation of the aggregate must be within the master grading limits for the specified grade except that a tolerance of 2 percentage points is allowed on the sieve size for each mixture grade that shows 100% passing in Table 2.

Ensure that the asphalt content does not vary by more than 0.5 percentage points from the design target.

- b. **Individual Loads of Asphalt-Stabilized Base.** The Engineer retains the right to reject individual truckloads of asphalt-stabilized base when it is evident that the material quality is unacceptable. When a load is rejected for reasons other than temperature, the Contractor may request that the rejected load be tested. Make this request within 4 hours of rejection. If Department test results are within the operational tolerances listed in Section 292.4.F.2.a, "Operational Tolerances," payment will be made for the load. If Department test results are not within operational tolerances, no payment will be made for the load.

292.4 to 292.4

3. **Placement Sampling and Testing.** Obtain two 6-in-diameter cores side by side at locations selected by the Engineer. Provide the Engineer an opportunity to witness the coring operation and measure the core thickness. Mark the cores for identification. Immediately after obtaining the cores, dry the core holes and tack the sides and bottom. Fill the hole with the same type of mixture and properly compact the mixture. Other methods of repairing the core holes are allowed when approved.

Trim the cores, if necessary, and deliver them to the Engineer within 1 working day following placement operations unless otherwise approved.

- a. **In-Place Air Voids.** The Engineer will measure in-place air voids in accordance with Tex-207-F and Tex-227-F to verify that in-place density requirements of Section 292.4.E.1, “Density Control,” are met.
 - b. **Irregularities.** Remove and replace, at the expense of the Contractor and to the satisfaction of the Engineer, any mixture that does not bond to the existing pavement or has other surface irregularities identified by the Engineer.
 - c. **Production Binder Properties.** The Engineer may take cores or other production samples at random from the project to determine recovered asphalt properties. Asphalt binders with an aging ratio greater than 3.5 do not meet requirements for recovered asphalt properties and may be deemed defective when tested and evaluated by the Construction Division. The aging ratio, as determined in accordance with AASHTO T 315, is the DSR value of the extracted binder divided by the DSR value of the original unaged binder. The binder from RAP will be included proportionally as part of the original unaged binder. The Engineer may require the defective material be removed and replaced at the Contractor’s expense. The asphalt binder will be recovered for testing from cores in accordance with Tex-211-F.
- G. Surface Finish.** Use Surface Test Type A in accordance with Item 585, “Ride Quality for Pavement Surfaces,” unless otherwise shown on the plans.
- H. Opening to Traffic.** Open the completed course to traffic when permitted or directed. If the surface ravels, flushes, ruts, or deteriorates in any manner before final acceptance, correct it at the Contractor’s expense and to the satisfaction of the Engineer.

292.5. Measurement. This Item will be measured by the ton of composite hot mix. The composite hot mix is defined as the asphalt, aggregate, RAP, and additives noted on the plans and approved by the Engineer. Measurement will be made using scales meeting the requirements of Item 520, “Weighing and Measuring Equipment.”

292.6. Payment. The work performed and materials furnished in accordance with this Item and measured as provided under “Measurement” will be paid for at the unit price bid for “Asphalt Stabilized Base” of the grade and binder type specified. This price is full compensation for furnishing and disposing of materials, producing trial batches, loading, hauling, placing, compacting, sampling, testing, replacing defective material, furnishing scales and labor for weighing and measuring, and equipment, labor, tools, and incidentals. State-owned RAP from sources designated on the plans shown to be available will be provided to the Contractor at no cost.

300 ITEMS — SURFACE COURSES AND PAVEMENT

ITEM 300

ASPHALTS, OILS, AND EMULSIONS

300.1. Description. Provide asphalt cements, cutback and emulsified asphalts, performance-graded asphalt binders, and other miscellaneous asphalt materials as specified on the plans.

300.2. Materials. Provide asphalt materials that meet the stated requirements when tested in accordance with the referenced Department, AASHTO, and ASTM test methods. Refer to the Material Inspection Guide (maintained by the Construction Division), Section 11. “Asphalt Inspection, Quality Control and Quality Assurance,” for sampling and testing requirements.

Acronyms used in this Item are defined in Table 1.

Table 1
Acronyms

Acronym	Definition
Test Procedure Designations	
Tex	Department
T or R	AASHTO
D	ASTM
Polymer Modifier Designations	
P	polymer-modified
SBR or L	styrene-butadiene rubber (latex)
SBS	styrene-butadiene-styrene block co-polymer
TR	tire rubber (from ambient temperature grinding of truck and passenger tires)
AC	asphalt cement
AE	asphalt emulsion
AE-P	asphalt emulsion prime
A-R	asphalt-rubber
C	cationic
EAP&T	emulsified asphalt prime and tack
H-suffix	harder residue (lower penetration)
HF	high float
MC	medium-curing

Table 1 (continued)
Acronyms

Acronym	Definition
MS	medium-setting
PCE	prime, cure, and erosion control
PG	performance grade
RC	rapid-curing
RS	rapid-setting
S-suffix	stockpile usage
SCM	special cutback material
SS	slow-setting

- A. Asphalt Cement.** Asphalt cement must be homogeneous, water-free, and nonfoaming when heated to 347°F, and must meet Table 2 requirements.

Table 2
Asphalt Cement

Property	Test Procedure	Viscosity Grade				
		AC-0.6 Min/Max	AC-1.5 Min/Max	AC-3 Min/Max	AC-5 Min/Max	AC-10 Min/Max
Viscosity 140°F, poise 275°F, poise	T 202	40 - 80	100 - 200	250 - 350	400 - 600	800 - 1,200
		0.4 -	0.7 -	1.1 -	1.4 -	1.9 -
Penetration, 77°F, 100g, 5 sec.	T 49	350 -	250 -	210 -	135 -	85 -
Flash point, C.O.C., °F	T 48	425 -	425 -	425 -	425 -	450 -
Solubility in trichloroethylene, %	T 44	99.0 -	99.0 -	99.0 -	99.0 -	99.0 -
Spot test	Tex-509-C	Neg.	Neg.	Neg.	Neg.	Neg.
Tests on residue from Thin-Film Oven Test: Viscosity, 140°F, poise Ductility ¹ , 77°F 5 cm/min., cm	T 179					
	T 202	- 180	- 450	- 900	- 1,500	- 3,000
	T 51	100 -	100 -	100 -	100 -	100 -

1. If AC-0.6 or AC-1.5 ductility at 77°F is less than 100 cm, material is acceptable if ductility at 60°F is more than 100 cm.

- B. Polymer-Modified Asphalt Cement.** Polymer-modified asphalt cement must be smooth and homogeneous, and comply with the requirements of Table 3. If requested, supply samples of the base asphalt cement and polymer additives.

**Table 3
Polymer-Modified Asphalt Cement**

Property	Test Procedure	Polymer-Modified Viscosity Grade									
		AC-5 w/2% SBR		AC-10 w/2% SBR		AC-15P		AC-20-5TR		TR	
		Min	Max	Min	Max	Min	Max	Min	Max	Min	Max
Polymer		SBR		SBR		SBS		SBS		TR	
Polymer content, % (solids basis)	Tex-533-C	2.0	-	2.0	-	3.0	-	5.0	-	5.0	-
Dynamic shear, G*/sin δ, 64°C, 10 rad/s, kPa	T 315	-	-	-	-	-	-	1.0	-	-	-
Viscosity											
140°F, poise	T 202	700	-	1,300	-	1,500	-	2,000	-	2,000	-
275°F, poise	T 202	-	7.0	-	8.0	-	8.0	-	8.0	-	10.0
Penetration, 77°F, 100 g, 5 sec.	T 49	120	-	80	-	100	150	75	115	-	-
Ductility, 5cm/min., 39.2°F, cm	T 51	70	-	60	-	-	-	-	-	-	-
Elastic recovery, 50°F, %	Tex-539-C	-	-	-	-	55	-	55	-	-	-
Softening point, °F	T 53	-	-	-	-	-	-	120	-	-	-
Polymer separation, 48 hr.	Tex-540-C	None		None		None		None		None	
Flash point, C.O.C., °F	T 48	425	-	425	-	425	-	425	-	425	-
Tests on residue from Thin-Film Oven Test:											
Retained penetration ratio, 77°F	T 179	-	-	-	-	0.60	1.00	0.60	1.00	-	-
Tests on residue from RTFOT aging and pressure aging:											
Creep stiffness	Tex-541-C and R 28	-	-	-	-	-	-	-	-	-	300
S, -18°C, MPa	T 313	-	-	-	-	-	-	-	-	0.300	-
m-value, -18°C		-	-	-	-	-	-	-	-	-	-

C. Cutback Asphalt. Cutback asphalt must meet the requirements of Tables 4, 5, and 6 for the specified type and grade. If requested, supply samples of the base asphalt cement and polymer additives.

**Table 4
Rapid-Curing Cutback Asphalt**

Property	Test Procedure	Type-Grade					
		RC-250		RC-800		RC-3000	
		Min	Max	Min	Max	Min	Max
Kinematic viscosity, 140°F, cSt	T 201	250	400	800	1,600	3,000	6,000
Water, %	T 55	—	0.2	—	0.2	—	0.2
Flash point, T.O.C., °F	T 79	80	—	80	—	80	—
Distillation test:	T 78						
Distillate, percentage by volume of total distillate to 680°F							
to 437°F		40	75	35	70	20	55
to 500°F		65	90	55	85	45	75
to 600°F		85	—	80	—	70	—
Residue from distillation, volume %		70	—	75	—	82	—
Tests on distillation residue:							
Penetration, 100 g, 5 sec., 77°F	T 49	80	120	80	120	80	120
Ductility, 5 cm/min., 77°F, cm	T 51	100	—	100	—	100	—
Solubility in trichloroethylene, %	T 44	99.0	—	99.0	—	99.0	—
Spot test	Tex-509-C	Neg.		Neg.		Neg.	

**Table 5
Medium-Curing Cutback Asphalt**

Property	Test Procedure	Type-Grade							
		MC-30		MC-250		MC-800		MC-3000	
		Min	Max	Min	Max	Min	Max	Min	Max
Kinematic viscosity, 140°F, cSt	T 201	30	60	250	500	800	1,600	3,000	6,000
Water, %	T 55	—	0.2	—	0.2	—	0.2	—	0.2
Flash point, T.O.C., °F	T 79	100	—	150	—	150	—	150	—
Distillation test:	T 78								
Distillate, percentage by volume of total distillate to 680°F									
to 437°F		—	25	—	10	—	—	—	—
to 500°F		40	70	15	55	—	35	—	15
to 600°F		75	93	60	87	45	80	15	75
Residue from distillation, volume %		50	—	67	—	75	—	80	—
Tests on distillation residue:									
Penetration, 100 g, 5 sec., 77°F	T 49	120	250	120	250	120	250	120	250
Ductility, 5 cm/min., 77°F, cm ¹	T 51	100	—	100	—	100	—	100	—
Solubility in trichloroethylene, %	T 44	99.0	—	99.0	—	99.0	—	99.0	—
Spot test	Tex-509-C	Neg.		Neg.		Neg.		Neg.	

1. If the penetration of residue is more than 200 and the ductility at 77°F is less than 100 cm, the material is acceptable if its ductility at 60°F is more than 100 cm.

Table 6
Special-Use Cutback Asphalt

Property	Test Procedure	Type-Grade					
		MC-2400L		SCM I		SCM II	
		Min	Max	Min	Max	Min	Max
Kinematic viscosity, 140°F, cSt	T 201	2,400	4,800	500	1,000	1,000	2,000
Water, %	T 55	—	0.2	—	0.2	—	0.2
Flash point, T.O.C., °F	T 79	150	—	175	—	175	—
Distillation test:	T 78						
Distillate, percentage by volume of total distillate to 680°F							
to 437°F		—	—	—	—	—	—
to 500°F		—	35	—	0.5	—	0.5
to 600°F		35	80	20	60	15	50
Residue from distillation, volume %		78	—	76	—	82	—
Tests on distillation residue:							
Polymer			SBR		—		—
Polymer content, % (solids basis)	Tex-533-C	2.0	—	—	—	—	—
Penetration, 100 g, 5 sec., 77°F	T 49	150	300	180	—	180	—
Ductility, 5 cm/min., 39.2°F, cm	T 51	50	—	—	—	—	—
Solubility in trichloroethylene, %	T 44	99.0	—	99.0	—	99.0	—

- D. Emulsified Asphalt.** Emulsified asphalt must be homogeneous, not separate after thorough mixing, and meet the requirements for the specified type and grade in Tables 7, 8, 9, and 10.

**Table 7
Emulsified Asphalt**

Property	Test Procedure	Type-Grade									
		Rapid-Setting		Medium-Setting				Slow-Setting			
		HFRS-2		MS-2		AES-300		SS-1		SS-1H	
	Min	Max	Min	Max	Min	Max	Min	Max	Min	Max	
Viscosity, Saybolt Furol 77°F, sec. 122°F, sec.	T 72	-	-	-	-	75	400	20	100	20	100
		150	400	100	300	-	-	-	-	-	-
Sieve test, %	T 59	-	0.1	-	0.1	-	0.1	-	0.1	-	0.1
Miscibility	T 59	-	-	-	-	-	-	-	Pass	-	Pass
Cement mixing, %	T 59	-	-	-	-	-	-	-	2.0	-	2.0
Coating ability and water resistance: dry aggregate/after spray wet aggregate/after spray	T 59	-	-	-	-	Good/Fair	-	-	-	-	-
		-	-	-	-	Fair/Fair	-	-	-	-	-
Demulsibility, 35 ml of 0.02 N CaCl ₂ , %	T 59	50	-	-	30	-	-	-	-	-	-
Storage stability, 1 day, %	T 59	-	1	-	1	-	1	-	1	-	1
Freezing test, 3 cycles ¹	T 59	-	-	-	Pass	-	-	-	Pass	-	Pass
Distillation test: Residue by distillation, % by wt. Oil distillate, % by volume of emulsion	T 59	65	-	65	-	65	-	60	-	60	-
		-	0.5	-	0.5	-	5	-	0.5	-	0.5
Tests on residue from distillation: Penetration, 77°F, 100 g, 5 sec. Solubility in trichloroethylene, % Ductility, 77°F, 5 cm/min., cm Float test, 140°F, sec.	T 49	100	140	120	160	300	-	120	160	70	100
	T 44	97.5	-	97.5	-	97.5	-	97.5	-	97.5	-
	T 51	100	-	100	-	100	-	100	-	80	-
	T 50	1,200	-	-	-	1,200	-	-	-	-	-

1. Applies only when the Engineer designates material for winter use.

Table 8
Cationic Emulsified Asphalt

Property	Test Procedure	Type-Grade									
		Rapid-Setting		Medium-Setting		Slow-Setting					
		CRS-2 Min: Max	CRS-2H Min: Max	CMS-2 Min: Max	CMS-2S Min: Max	CSS-1 Min: Max	CSS-1H Min: Max				
Viscosity, Saybolt Furol 77°F, sec. 122°F, sec.	T 72	-	-	-	-	-	-	20	100	20	100
		150	400	150	400	100	300	100	300	-	-
Sieve test, %	T 59	-	0.1	-	0.1	-	0.1	-	0.1	-	0.1
Cement mixing, %	T 59	-	-	-	-	-	-	-	-	2.0	2.0
Coating ability and water resistance: dry aggregate/after spray wet aggregate/after spray	T 59	-	-	Good/Fair	Good/Fair	Good/Fair	Good/Fair	-	-	-	-
		-	-	Fair/Fair	Fair/Fair	Fair/Fair	Fair/Fair	-	-	-	-
Demulsibility, 35 ml of 0.8% sodium dioctyl sulfosuccinate, %	T 59	70	-	70	-	-	-	-	-	-	-
Storage stability, 1 day, %	T 59	-	1	-	1	-	1	-	1	-	1
Particle charge	T 59	Positive	Positive	Positive	Positive	Positive	Positive	Positive	Positive	Positive	Positive
Distillation test: Residue by distillation, % by wt. Oil distillate, % by volume of emulsion	T 59	65	-	65	-	65	-	65	-	60	-
		-	0.5	-	0.5	-	7	-	5	-	0.5
Tests on residue from distillation: Penetration, 77°F, 100 g, 5 sec. Solubility in trichloroethylene, % Ductility, 77°F, 5 cm/min., cm	T 49	120	160	70	110	120	200	300	-	120	160
	T 44	97.5	-	97.5	-	97.5	-	97.5	-	97.5	-
	T 51	100	-	80	-	100	-	100	-	100	-

Table 9
Polymer-Modified Emulsified Asphalt

Property	Test Procedure	Type-Grade											
		Rapid-Setting			Medium-Setting			Slow-Setting					
		RS-IP Min	HFERS-2P Min	AES-150P Min	AES-300P Min	AES-300S Min	SS-IP Min	RS-IP Max	HFERS-2P Max	AES-150P Max	AES-300P Max	AES-300S Max	SS-IP Max
Viscosity, Saybolt Furol 77°F, sec. 122°F, sec.	T 72	-	-	75	400	75	400	75	400	30	100	-	-
Sieve test, %	T 59	-	0.1	-	0.1	-	0.1	-	0.1	-	0.1	-	0.1
Miscibility	T 59	-	-	-	-	-	-	-	-	-	-	-	Pass
Coating ability and water resistance: dry aggregate/after spray wet aggregate/after spray	T 59	-	-	Good/Fair Fair/Fair	Good/Fair Fair/Fair	Good/Fair Fair/Fair	Good/Fair Fair/Fair	Good/Fair Fair/Fair	Good/Fair Fair/Fair	Good/Fair Fair/Fair	Good/Fair Fair/Fair	-	-
Demulsibility, 35 ml of 0.02 N CaCl ₂ , %	T 59	60	-	-	-	-	-	-	-	-	-	-	-
Storage stability, 1 day, %	T 59	-	1	-	1	-	1	-	1	-	1	-	1
Breaking index, g	Tex-542-C	-	80	-	-	-	-	-	-	-	-	-	-
Distillation test: ¹ Residue by distillation, % by wt. Oil distillate, % by volume of emulsion	T 59	65	65	65	3	65	65	65	5	65	65	60	0.5
Tests on residue from distillation:													
Polymer content, wt. % (solids basis)	Tex-533-C	-	3.0	-	-	-	-	-	-	-	-	3.0	-
Penetration, 77°F, 100 g, 5 sec.	T 49	225	300	150	300	300	300	300	300	300	300	100	140
Solubility in trichloroethylene, %	T 44	97.0	-	97.0	-	97.0	-	97.0	-	97.0	-	97.0	-
Viscosity, 140°F, poise	T 202	-	1,500	-	-	-	-	-	-	-	-	1,300	-
Float test, 140°F, sec.	T 50	-	1,200	-	-	1,200	-	-	-	1,200	-	1,200	-
Ductility ² , 39.2°F, 5 cm/min., cm	T 51	-	50	-	-	-	-	-	-	-	-	50	-
Elastic recovery ² , 50°F, %	Tex-539-C	55	-	-	-	-	-	-	-	-	-	-	-
Tests on RTFO curing of distillation residue													
Elastic recovery, 50°F, %	Tex-541-C	-	-	50	-	50	-	50	-	50	-	30	-
Tex-539-C		-	-	-	-	-	-	-	-	-	-	-	-

1. Exception to T 59: Bring the temperature on the lower thermometer slowly to 350°F ±10°F. Maintain at this temperature for 20 min. Complete total distillation in 60 ±5 min. from the first application of heat.

2. HFERS-2P must meet one of either the ductility or elastic recovery requirements.

Table 10
Polymer-Modified Cationic Emulsified Asphalt

Property	Test Procedure	Type-Grade					
		Rapid-Setting				Slow-Setting	
		CRS-1P		CRS-2P		CSS-1P	
		Min	Max	Min	Max	Min	Max
Viscosity, Saybolt Furol 77°F, sec. 122°F, sec.	T 72	–	–	–	–	20	100
Sieve test, %	T 59	–	0.1	–	0.1	–	0.1
Demulsibility, 35 ml of 0.8% sodium dioctyl sulfosuccinate, %	T 59	60	–	70	–	–	–
Storage stability, 1 day, %	T 59	–	1	–	1	–	1
Breaking index, g	Tex-542-C	–	80	–	–	–	–
Particle charge	T 59	Positive		Positive		Positive	
Distillation test: ¹ Residue by distillation, % by weight Oil distillate, % by volume of emulsion	T 59	65	–	65	–	62	–
		–	3	–	0.5	–	0.5
Tests on residue from distillation: Polymer content, wt. % (solids basis)	Tex-533-C	–	–	3.0	–	3.0	–
Penetration, 77°F, 100 g, 5 sec.	T 49	225	300	90	150	55	90
Viscosity, 140°F, poise	T 202	–	–	1,300	–	–	–
Solubility in trichloroethylene, %	T 44	97.0	–	97.0	–	97.0	–
Softening point, °F	T 53	–	–	–	–	135	–
Ductility, 77°F, 5 cm/min., cm	T 51	–	–	–	–	70	–
Ductility ² , 39.2°F, 5 cm/min., cm	T 51	–	–	50	–	–	–
Elastic recovery ² , 50°F, %	Tex-539-C	45	–	55	–	–	–

1. Exception to T 59: Bring the temperature on the lower thermometer slowly to 350°F ±0°F. Maintain at this temperature for 20 min. Complete total distillation in 60 ±5 min. from the first application of heat.

2. CRS-2P must meet one of either the ductility or elastic recovery requirements.

E. Specialty Emulsions. Specialty emulsions may be either asphalt-based or resin-based and must meet the requirements of Table 11.

**Table 11
Specialty Emulsions**

Property	Test Procedure	Type-Grade					
		Medium-Setting				Slow-Setting	
		AE-P		EAP&T		PCE ¹	
		Min	Max	Min	Max	Min	Max
Viscosity, Saybolt Furol 77°F, sec. 122°F, sec.	T 72	-	-	-	-	10	100
Sieve test, %	T 59	-	0.1	-	0.1	-	0.1
Miscibility ²	T 59	-	-	Pass	-	Pass	-
Demulsibility, 35 ml of 0.10 N CaCl ₂ , %	T 59	-	70	-	-	-	-
Storage stability, 1 day, %	T 59	-	1	-	1	-	-
Particle size ³ , % by volume < 2.5 µm	Tex-238-F ³	-	-	90	-	90	-
Asphalt emulsion distillation to 500°F followed by Cutback asphalt distillation of residue to 680°F: Residue after both distillations, % by wt. Total oil distillate from both distillations, % by volume of emulsion	T 59 & T 78	40	-	-	-	-	-
Residue by distillation, % by wt.	T 59	-	-	60	-	-	-
Residue by evaporation ⁴ , % by wt.	T 59	-	-	-	-	60	-
Tests on residue after all distillation(s): Viscosity, 140°F, poise Kinematic viscosity ⁵ , 140°F, cSt Flash point C.O.C., °F Solubility in trichloroethylene, % Float test, 122°F, sec.	T 202 T 201 T 48 T 44 T 50	-	-	800	-	-	-
		-	-	-	-	100	350
		-	-	-	-	400	-
		97.5	-	-	-	-	-
		50	200	-	-	-	-

1. Supply with each shipment of PCE:

a) a copy of a lab report from an approved analytical lab, signed by a lab official, indicating the PCE formulation does not meet any characteristics of a Resource Conservation Recovery Act (RCRA) hazardous waste;

b) a certification from the producer that the formulation supplied does not differ from the one tested and that no listed RCRA hazardous wastes or PCBs have been mixed with the product; and

c) a Material Safety Data Sheet.

2. Exception to T 59: In dilution, use 350 ml of distilled or deionized water and a 1,000-ml beaker.

3. Use Tex-238-F, beginning at “Particle Size Analysis by Laser Diffraction,” with distilled or deionized water as a medium and no dispersant, or use another approved method.

4. Exception to T 59: Leave sample in the oven until foaming ceases, then cool and weigh.

5. PCE must meet either the kinematic viscosity requirement or the particle size requirement.

F. Recycling Agent. Recycling agent and emulsified recycling agent must meet the requirements in Table 12. Additionally, recycling agent and residue from emulsified recycling agent, when added in the specified proportions to the recycled asphalt, must meet the properties specified on the plans.

Table 12
Recycling Agent and Emulsified Recycling Agent

Property	Test Procedure	Recycling Agent		Emulsified Recycling Agent	
		Min	Max	Min	Max
Viscosity, Saybolt Furol, 77°F, sec.	T 72	–	–	15	100
Sieve test, %	T 59	–	–	–	0.1
Miscibility ¹	T 59	–		No coagulation	
Residue by evaporation ² , % by wt.	T 59	–	–	60	–
Tests on recycling agent or residue from evaporation:					
Flash point, C.O.C., °F	T 48	400	–	400	–
Kinematic viscosity, 140°F, cSt	T 201	75	200	75	200
275°F, cSt		–	10.0	–	10.0

1. Exception to T 59: Use 0.02 N CaCl₂ solution in place of water.

2. Exception to T 59: Maintain sample at 300°F until foaming ceases, then cool and weigh.

G. Crumb Rubber Modifier. Crumb rubber modifier (CRM) consists of automobile and truck tires processed by ambient temperature grinding.

CRM must be:

- free from contaminants including fabric, metal, and mineral and other nonrubber substances;
- free-flowing; and
- nonfoaming when added to hot asphalt binder.

When tested in accordance with Tex-200-F, Part I, using a 50-g sample, the rubber gradation must meet the requirements of the grades in Table 13.

Table 13
CRM Gradations

Sieve Size (% Passing)	Grade A		Grade B		Grade C		Grade D	Grade E
	Min	Max	Min	Max	Min	Max		
#8	100	–	–	–	–	–	As shown on the plans	As approved
#10	95	100	100	–	–	–		
#16	–	–	70	100	100	–		
#30	–	–	25	60	90	100		
#40	–	–	–	–	45	100		
#50	0	10	–	–	–	–		
#200	–	–	0	5	–	–		

300.2 to 300.2

H. Crack Sealer. Polymer modified asphalt-emulsion crack sealer must meet the requirements of Table 14. Rubber-asphalt crack sealer must meet the requirements of Table 15.

**Table 14
Polymer-Modified Asphalt Emulsion Crack Sealer**

Property	Test Procedure	Min	Max
Rotational viscosity, 77°F, cP	D 2196, Method A	10,000	25,000
Sieve test, %	T 59	–	0.1
Storage stability, 1 day, %	T 59	–	1
Evaporation Residue by evaporation, % by wt.	Tex-543-C	65	–
Tests on residue from evaporation: Penetration, 77°F, 100 g, 5 sec.	T 49	35	75
Softening point, °F	T 53	140	–
Ductility, 39.2°F, 5 cm/min., cm	T 51	100	–

**Table 15
Rubber-Asphalt Crack Sealer**

Property	Test Procedure	Class A		Class B	
		Min	Max	Min	Max
CRM content, Grade A or B, % by wt.	Tex-544-C	22	26	–	–
CRM content, Grade B, % by wt.	Tex-544-C	–	–	13	17
Virgin rubber content ¹ , % by wt.		–	–	2	–
Flash point ² , COC, °F	T 48	400	–	400	–
Penetration ³ , 77°F, 150 g, 5 sec.	T 49	30	50	30	50
Penetration ³ , 32°F, 200 g, 60 sec.	T 49	12	–	12	–
Softening point, °F	T 53	–	–	170	–
Bond ⁴	D5329	–	–	Pass	–

1. Provide certification that the min. % virgin rubber was added.
2. Before passing the test flame over the cup, agitate the sealing compound with a 3/8- to 1/2-in. (9.5- to 12.7-mm) wide, square-end metal spatula in a manner so as to bring the material on the bottom of the cup to the surface, i.e., turn the material over. Start at one side of the thermometer, move around to the other, and then return to the starting point using 8 to 10 rapid circular strokes. Accomplish agitation in 3 to 4 sec. Pass the test flame over the cup immediately after stirring is completed.
3. Exception to T 49: Substitute the cone specified in ASTM D 217 for the penetration needle.
4. No crack in the crack sealing materials or break in the bond between the sealer and the mortar blocks over 1/4 in. deep for any specimen after completion of the test.

I. Asphalt-Rubber Binders. Asphalt-rubber (A-R) binders are mixtures of asphalt binder and CRM, which have been reacted at elevated temperatures. The A-R binders meet D 6114 and contain a minimum of 15% CRM by weight. Types I or II, containing CRM Grade C, are used

for hot mixed aggregate mixtures. Types II or III, containing CRM Grade B, are used for surface treatment binder. Table 16 describes required binder properties.

Table 16
A-R Binders

Property	Test Procedure	Binder Type					
		Type I		Type II		Type III	
		Min	Max	Min	Max	Min	Max
Apparent viscosity, 347°F, cP	D 2196, Method A	1,500	5,000	1,500	5,000	1,500	5,000
Penetration, 77°F, 100 g, 5 sec.	T 49	25	75	25	75	50	100
Penetration, 39.2°F, 200 g, 60 sec.	T 49	10	–	15	–	25	–
Softening point, °F	T 53	135	–	130	–	125	–
Resilience, 77°F, %	D 5329	25	–	20	–	10	–
Flash point, C.O.C., °F	T 48	450	–	450	–	450	–
Tests on residue from Thin-Film Oven Test:	T 179						
Retained penetration ratio, 39.2°F, 200 g, 60 sec., % of original	T 49	75	–	75	–	75	–

J. Performance-Graded Binders. PG binders must be smooth and homogeneous, show no separation when tested in accordance with Tex-540-C, and meet Table 17 requirements.

Separation testing is not required if:

- a modifier is introduced separately at the mix plant either by injection in the asphalt line or mixer,
- the binder is blended on site in continuously agitated tanks, or
- binder acceptance is based on field samples taken from an in-line sampling port at the hot mix plant after the addition of modifiers.

Table 17
Performance-Graded Binders

Property and Test Method	Performance Grade														
	PG 58		PG 64		PG 70		PG 76		PG 82						
	-22	-28	-34	-16	-22	-28	-34	-16	-22	-28	-34	-16	-22	-28	
Average 7-day max pavement design temperature, °C ¹	< 58	< 64	< 70	< 76	< 82										
Min pavement design temperature, °C ¹	>22	>28	>34	>16	>22	>28	>34	>16	>22	>28	>34	>16	>22	>28	
ORIGINAL BINDER															
Flash point, T 48, Min, °C	230														
Viscosity, T 316: ^{2,3}	135														
Max, 3.0 Pa.s, test temperature, °C	70														
Dynamic shear, T 315: ⁴	76														
G*/sin(δ), Min, 1.00 kPa	82														
Test temperature @ 10 rad/sec., °C															
Elastic recovery, D 6084, 50°F, % Min	-	-	30	-	-	30	50	-	30	50	60	30	50	60	70
ROLLING THIN-FILM OVEN (Tex-541-C)															
Mass loss, Tex-541-C, Max, %	1.0														
Dynamic shear, T 315:	70														
G*/sin(δ), Min, 2.20 kPa	76														
Test temperature @ 10 rad/sec., °C	82														
PRESSURE AGING VESSEL (PAV) RESIDUE (R 28)															
PAV aging temperature, °C	100														
Dynamic shear, T 315:	25														
G*/sin(δ), Max, 5000 kPa	25	22	19	28	25	22	19	28	25	22	19	28	25	22	
Test temperature @ 10 rad/sec., °C															

**Table 17 (continued)
Performance-Graded Binders**

Property and Test Method	Performance Grade																	
	PG 58			PG 64			PG 70			PG 76			PG 82					
	-22	-28	-34	-16	-22	-28	-34	-16	-22	-28	-34	-16	-22	-28	-16	-22	-28	
Average 7-day max pavement design temperature, °C ¹	< 58			< 64			< 70			< 76			< 82					
Min pavement design temperature, °C ¹	>22	>28	>34	>16	>22	>28	>34	>16	>22	>28	>34	>16	>22	>28	>16	>22	>28	
Creep stiffness, T 313. ^{5,6}																		
S, max, 300 MPa, <i>m</i> -value, min, 0.300 Test temperature @ 60 sec., °C	-12	-18	-24	-6	-12	-18	-24	-6	-12	-18	-24	-6	-12	-18	-24	-6	-12	-18
Direct tension, T 314. ⁶ Failure strain, min, 1.0% Test temperature @ 1.0 mm/min., °C	-12	-18	-24	-6	-12	-18	-24	-6	-12	-18	-24	-6	-12	-18	-24	-6	-12	-18

1. Pavement temperatures are estimated from air temperatures using an algorithm contained in a Department-supplied computer program, may be provided by the Department, or by following the procedures outlined in AASHTO MP 2 and PP 28.
2. This requirement may be waived at the Department's discretion if the supplier warrants that the asphalt binder can be adequately pumped, mixed, and compacted at temperatures that meet all applicable safety, environmental, and constructability requirements. At test temperatures where the binder is a Newtonian fluid, any suitable standard means of viscosity measurement may be used, including capillary (T 201 or T 202) or rotational viscometry (T 316).
3. Viscosity at 135°C is an indicator of mixing and compaction temperatures that can be expected in the lab and field. High values may indicate high mixing and compaction temperatures. Additionally, significant variation can occur from batch to batch. Contractors should be aware that variation could significantly impact their mixing and compaction operations. Contractors are therefore responsible for addressing any constructability issues that may arise.
4. For quality control of unmodified asphalt binder production, measurement of the viscosity of the original asphalt binder may be substituted for dynamic shear measurements of $G^*/\sin(\delta)$ at test temperatures where the asphalt is a Newtonian fluid. Any suitable standard means of viscosity measurement may be used, including capillary (T 201 or T 202) or rotational viscometry (T 316).
5. Silicone beam molds, as described in AASHTO TP 1-93, are acceptable for use.
6. If creep stiffness is below 300 MPa, direct tension test is not required. If creep stiffness is between 300 and 600 MPa, the direct tension failure strain requirement can be used instead of the creep stiffness requirement. The *m*-value requirement must be satisfied in both cases.

300.3 to 300.4

300.3. Equipment. Provide all equipment necessary to transport, store, sample, heat, apply, and incorporate asphalts, oils, and emulsions.

300.4. Construction.

A. Typical Material Use. Table 18 shows typical materials used for specific applications. These are typical uses only. Circumstances may require use of other material.

**Table 18
Typical Material Use**

Material Application	Typically Used Materials
Hot-mixed, hot-laid asphalt mixtures	PG binders, A-R binders Types I and II
Surface treatment	AC-5, AC-10, AC-5 w/2% SBR, AC-10 w/2% SBR, AC-15P, AC-20-5TR, HFRS-2, MS-2, CRS-2, CRS-2H, HFRS-2P, CRS-2P, A-R binders Types II and III
Surface treatment (cool weather)	RS-1P, CRS-1P, RC-250, RC-800, RC-3000, MC-250, MC-800, MC-3000, MC-2400L
Precoating	AC-5, AC-10, PG 64-22, SS-1, SS-1H, CSS-1, CSS-1H
Tack coat	PG Binders, SS-1H, CSS-1H, EAP&T
Fog seal	SS-1, SS-1H, CSS-1, CSS-1H
Hot-mixed, cold-laid asphalt mixtures	AC-0.6, AC-1.5, AC-3, AES-300, AES-300P, CMS-2, CMS-2S
Patching mix	MC-800, SCM I, SCM II, AES-300S
Recycling	AC-0.6, AC-1.5, AC-3, AES-150P, AES-300P, recycling agent, emulsified recycling agent
Crack sealing	SS-1P, polymer mod AE crack sealant, rubber asphalt crack sealers (Class A, Class B)
Microsurfacing	CSS-1P
Prime	MC-30, AE-P, EAP&T, PCE
Curing membrane	SS-1, SS-1H, CSS-1, CSS-1H, PCE
Erosion control	SS-1, SS-1H, CSS-1, CSS-1H, PCE

B. Storage and Application Temperatures. Use storage and application temperatures in accordance with Table 19. Store and apply materials at the lowest temperature yielding satisfactory results. Follow the manufacturer’s instructions for any agitation requirements in storage. Manufacturer’s instructions regarding recommended application and storage temperatures supercede those of Table 19.

Table 19
Storage and Application Temperatures

Type-Grade	Application		Storage Maximum (°F)
	Recommended Range, °F	Maximum Allowable (°F)	
AC-0.6, AC-1.5, AC-3	200–300	350	350
AC-5, AC-10	275–350	350	350
AC-5 w/2% SBR, AC-10 w/2% SBR, AC-15P, AC-20-5TR	300–375	375	360
RC-250	125–180	200	200
RC-800	170–230	260	260
RC-3000	215–275	285	285
MC-30, AE-P	70–150	175	175
MC-250	125–210	240	240
MC-800, SCM I, SCM II	175–260	275	275
MC-3000, MC-2400L	225–275	290	290
HFRS-2, MS-2, CRS-2, CRS-2H, HFRS-2P, CRS-2P, CMS-2, CMS-2S, AES-300, AES-300S, AES-150P, AES-300P	120–160	180	180
SS-1, SS-1H, CSS-1, CSS-1H, PCE, EAP&T, SS-1P, RS-1P, CRS-1P, CSS-1P, recycling agent, emulsified recycling agent, polymer mod AE crack sealant	50–130	140	140
PG binders	275–350	350	350
Rubber asphalt crack sealers (Class A, Class B)	350–375	400	–
A-R binders Types I, II, and III	325–425	425	425

300.5. Measurement and Payment. The work performed, materials furnished, equipment, labor, tools, and incidentals will not be measured or paid for directly, but is subsidiary or is included in payment for other bid items.

ITEM 301

ASPHALT ANTISTRIPPING AGENTS

301.1. Description. Furnish and incorporate all required asphalt antistripping agents in asphalt concrete paving mixtures and asphalt-stabilized base mixtures to meet moisture resistance testing requirements.

301.2 to 301.4

301.2. Materials.

- A. Lime.** Provide hydrated lime or commercial lime slurry in accordance with DMS-6350, “Lime and Lime Slurry.”
- B. Liquid Antistripping Agent.** Provide a liquid antistripping agent that is uniform and shows no evidence of crystallization, settling, or separation.

Ensure that all liquid antistripping agents arrive in:

- properly labeled and unopened containers, as shipped from the manufacturer, or
- sealed tank trucks with an invoice to show contents and quantities.
- Provide product information to the Engineer including:
- material safety data sheet,
- specific gravity of the agent at the manufacturer’s recommended addition temperature,
- manufacturer’s recommended dosage range, and
- handling and storage instructions.

301.3. Equipment. Provide all equipment to store, handle, dispense, meter, and mix asphalt antistripping agents.

301.4. Construction.

- A. Laboratory Design Evaluation and Production Mixture Verification.** Provide a laboratory mixture design and production mixture that meet moisture resistance requirements. During design and production, evaluate proposed asphalt pavement or base mixtures according to the moisture resistance requirements in the asphalt mixture specification.

Governing specifications require the Contractor or Engineer to design the mixture, and the party performing the design is responsible for the moisture susceptibility evaluation. If the Contractor designs the mixture, the Engineer verifies compliance.

If an antistripping agent is required, determine the dosage needed to achieve the moisture resistance requirements during design. Use this addition rate in the production mixture.

When using lime, add between 0.5% and 2.0% of hydrated lime or commercial lime slurry solids by weight of the individual aggregate treated.

When using a liquid antistripping agent, add it to the binder in accordance with the manufacturer's instructions and do not exceed the manufacturer's maximum recommended dosage rate.

If the production mixture does not meet moisture resistance requirements, stop production and correct the problem.

- B. Addition of Antistripping Agents at the Mix Plant.** Connect the measuring device for the addition of the asphalt antistripping agent into the automatic plant controls to automatically adjust the supply to plant production and provide a consistent percentage in the mixture. Set automatic plant controls so that an interruption of asphalt antistripping agent's flow causes plant shutdown.
1. **Lime.** Incorporate lime in a manner that thoroughly and uniformly distributes lime onto the aggregate surface or into the mixture. Use metering equipment, as approved, to ensure the required quantity of lime is used.
 - a. **Hydrated Lime.** Add to the aggregate by one of the following methods, unless otherwise shown on the plans:
 - Mix in an approved pug mill mixer with damp aggregate containing water at least 2% above saturated surface dry conditions.
 - Add into the drum-mix plant immediately before asphalt binder addition or in the pug mill of the weigh-batch plant before asphalt binder addition. If a weigh-batch plant is used, dry mix aggregates and lime before adding asphalt binder.
 - b. **Commercial Lime Slurry.** Add to the aggregate by one of the following methods, unless otherwise shown on the plans:
 - Mix in a suitable pug mill mixer with the aggregate.
 - During mixture production, mix with aggregate between the plant cold feeds and the dryer or mixing drum.
 2. **Liquid Antistripping Agent.** Incorporate into the binder as follows:
 - Handle in accordance with the manufacturer's recommendations.
 - Add at the manufacturer's recommended addition temperature.
 - Add into the asphalt line by means of an in-line-metering device, in accordance with Item 520, "Weighing and Measuring Equipment," and a blending device to disperse the agent.

301.5 to 302.2

- Place the metering and blending devices in an approved location.

301.5. Measurement and Payment. The work performed, materials furnished, equipment, labor, tools, and incidentals will not be measured or paid for directly, but is subsidiary or is included in payment quantity for pertinent Items.

ITEM 302

AGGREGATES FOR SURFACE TREATMENTS

302.1. Description. Furnish aggregate for surface treatments in conformance to the type, grade, and surface aggregate classification (SAC) shown on the plans.

302.2. Materials. Furnish uncontaminated materials of uniform quality throughout that meet the requirements of the plans and specifications. Notify the Engineer of all proposed material sources and of changes to material sources. The Engineer will designate the sampling location.

- A. Aggregate.** Stockpile aggregates for each source and type separately. Do not add materials to approved stockpiles without the approval of the Engineer.

Furnish aggregate of the type shown on the plans and listed in Table 1. Use Tex-100-E material definitions.

Table 1
Aggregate Types

Type	Material
A	Gravel, crushed slag, crushed stone, or limestone rock asphalt (LRA)
B	Crushed gravel, crushed slag, crushed stone, or LRA
C	Gravel, crushed slag, or crushed stone
D	Crushed gravel, crushed slag, or crushed stone
E	Aggregate as shown on plans
L	Lightweight Aggregate
PA	Precoated gravel, crushed slag, crushed stone, or LRA
PB	Precoated crushed gravel, crushed slag, crushed stone, or LRA
PC	Precoated gravel, crushed slag, or crushed stone
PD	Precoated crushed gravel, crushed slag, crushed stone
PE	Precoated aggregate as shown on the plans
PL	Precoated lightweight aggregate

When tested in accordance with Tex-200-F, Part I, the aggregate gradation must meet the requirements in Table 2 for the specified grade.

Furnish aggregates that meet the quality requirements shown in Table 3, unless otherwise shown on the plans. Provide aggregates from sources listed in the Department's *Bituminous Rated Source Quality Catalog* (BRSQC). If a source is not listed in the catalog or its listed ratings do not meet requirements of the plans, material from that source may be used only when tested by the Engineer and approved before use. Allow 30 calendar days for testing of material from such sources.

Provide aggregates for final surfaces that meet the SAC shown on the plans. Do not blend to meet the SAC. Unless otherwise shown, the SAC requirement will apply only to the aggregate used on the travel lanes. The BRSQC lists the SAC for sources on the Aggregate Quality Monitoring Program (AQMP).

Table 2
Aggregate Gradation Requirements (Cumulative % Retained¹)

Sieve	Grade								
	1	2	3S ²	3		4S ²	4	5S ²	5
				Non-lightweight	Lightweight				
1"	—	—	—	—	—	—	—	—	—
7/8"	0–2	0	—	—	—	—	—	—	—
3/4"	20–35	0–2	0	0	0	—	—	—	—
5/8"	85–100	20–40	0–5	0–2	0–2	0	0	—	—
1/2"	—	80–100	55–85	20–40	10–25	0–5	0–5	0	0
3/8"	95–100	95–100	95–100	80–100	60–80	60–85	20–40	0–5	0–5
1/4"	—	—	—	95–100	95–100	—	—	65–85	—
#4	—	—	—	—	—	95–100	95–100	95–100	50–80
#8	99–100	99–100	99–100	99–100	98–100	98–100	98–100	98–100	98–100

1. Round test results to the nearest whole number.
2. Single-size gradation.

**Table 3
Aggregate Quality Requirements**

Property	Test Method	Requirement	Remarks
SAC	AQMP	As shown on the plans	
Deleterious material, %, max	Tex-217-F, Part I	2.0	Not required for lightweight aggregate. For LRA, deleterious material includes iron pyrites
Decantation, %, max	Tex-406-A	1.5	
Flakiness index, max	Tex-224-F	17	Unless otherwise shown on the plans
Los Angeles abrasion, %, max	Tex-410-A	35	All aggregates except LRA
		40	LRA
Magnesium sulfate soundness, 5 Cycle, %, max	Tex-411-A	25	
Micro-Deval abrasion, %, max	Tex-461-A	–	Not used for acceptance purposes. Used by the Engineer as an indicator for further investigation.
Coarse aggregate angularity, 2 crushed faces, %, Min	Tex-460-A, Part I	85	Unless otherwise shown on the plans. Only required for crushed gravel
Additional Requirements for Lightweight Aggregate			
Dry loose unit wt., lb./cu. ft.	Tex-404-A	35–60	
Pressure slaking, %, max	Tex-431-A	6.0	
Freeze-thaw loss, %, max	Tex-432-A	10.0	
Water absorption, 24 ^o hr., %, max	Tex-433-A	12.0	Unless otherwise shown on plans.
Additional Requirements for Natural LRA			
Naturally impregnated bitumen content, % by wt.	Tex-236-F	4.0–7.0	
White rock content, % by wt.	Tex-220-F and Tex-236-F	15–35	Applies to aggregate retained on the #4 sieve

B. Precoating. When precoating is shown on the plans, precoat aggregate uniformly and adequately with asphalt material to the satisfaction of the Engineer. When shown on the plans, specific aggregates may be prohibited from being pre-coated. Do not precoat LRA aggregate that contains visual surface moisture or excessive quantities of fines. Meet Table 2 and 3 requirements before pre-coating. Furnish pre-coated aggregate that spreads uniformly using approved mechanical spreading equipment.

The Engineer retains the right to select a target value for the desired percent by weight of residual bitumen coating on the aggregate. Furnish precoated aggregate that is within $\pm 0.3\%$ of the target value when tested in accordance with Tex-236-F. The Engineer may require trial batches to assist in selecting the target value.

The Engineer retains the right to remove precoat material from aggregate samples in accordance with Tex-210-F and test the aggregate to verify compliance with Table 2 and 3 requirements. Gradation testing may be performed with precoat intact.

1. **Asphalt Material.** Precoat the aggregates with asphalt material that meets the requirements of Item 300, "Asphalts, Oils, and Emulsions." Precoat the LRA with flux oil meeting the requirements of Item 330, "Limestone Rock Asphalt Pavement." Unless a specific precoat material is specified on the plans, use any asphalt material that meets the requirements of Item 300.
2. **Additives.** When shown on the plans, use the type and rate of additive specified. Add in accordance with Item 301, "Asphalt Antistripping Agents." Tex-530-C will be used for verification during production testing, unless otherwise directed.

302.3. Equipment. Manufacture precoated aggregate in a mixing plant that produces uniformly coated aggregate.

302.4. Construction. Deliver aggregate to the locations shown on the plans. Prevent segregation, mixing of the various materials or sizes, and contamination with foreign materials when aggregates are stockpiled. The Engineer will reject contaminated stockpiles.

Provide adequate initial cooling of precoated aggregate to prevent asphalt or aggregate damage due to excessive heat buildup in stockpiles. When asphalt cement is the precoating material, limit stockpile height to 3 ft. immediately after production. Consolidate stockpiles after adequate cooling, as approved. The Engineer will reject stockpiles showing evidence of damage due to excessive heat buildup.

302.5. Measurement and Payment. The work performed, materials furnished, equipment, tools, and incidentals will not be measured or paid for directly but is subsidiary to or is included under "Payment" in other pertinent Items.

305.1 to 305.4

ITEM 305

SALVAGING, HAULING, AND STOCKPILING RECLAIMABLE ASPHALT PAVEMENT

305.1. Description. Salvage, haul, and stockpile existing asphalt material.

305.2. Construction. Remove dirt, raised pavement markings, and other debris, as directed. Remove the reclaimable asphalt material as shown on the plans or as directed. Unless otherwise shown on the plans, ensure that 95% of the reclaimed material passes a 2-in. sieve. Do not contaminate asphalt material during its removal, transportation, or storage. Repair pavement to remain that is damaged by the removal operations.

Provide a clean, smooth, and well-drained stockpile area free of trash, weeds, and grass. Separate different types or quality of asphalt material into different stockpiles as directed. Stockpile material as shown on the plans or as directed.

The Department retains ownership of the reclaimed asphalt material, unless otherwise shown on the plans. The plans or the Engineer may allow or require the use of salvaged material for other Items in the Contract. If not used in other construction items of this Contract, stockpile the salvaged material at the location shown on the plans or as directed.

305.3. Measurement. This Item will be measured by the cubic yard of material calculated by the average end area method in the stockpile, or by the square yard in its original position.

305.4. Payment. The work performed and materials furnished in accordance with this Item and measured as provided under “Measurement” will be paid for at the unit price bid for “Salvaging, Hauling, and Stockpiling Reclaimable Asphalt Pavement” for cubic yard measurement, and for “Salvaging, Hauling, and Stockpiling Reclaimable Asphalt Pavement (Depth Specified)” for square yard measurement. This price is full compensation for cleaning and removing existing pavement; stockpile area preparation; loading, crushing or breaking, hauling, and stockpiling material; and material, equipment, labor, tools, supplies, and incidentals.

ITEM 310
PRIME COAT

310.1. Description. Prepare and treat existing or newly constructed surface with a bituminous material. Apply blotter material as required.

310.2. Materials.

- A. Bituminous.** Use material of the type and grade shown on the plans in accordance with Item 300, "Asphalts, Oils, and Emulsions."
- B. Blotter.** Unless otherwise shown on the plans or approved, use either base course sweepings obtained from cleaning the base or native sand as blotter materials.

310.3. Equipment. Provide applicable equipment in accordance with Article 316.3, "Equipment."

310.4. Construction.

- A. General.** Apply the mixture when the air temperature is 60°F and above, or above 50°F and rising. Measure the air temperature in the shade away from artificial heat. The Engineer will determine when weather conditions are suitable for application.

Do not permit traffic, hauling, or placement of subsequent courses over freshly constructed prime coats. Maintain the primed surface until placement of subsequent courses or acceptance of the work.

- B. Surface Preparation.** Prepare the surface by sweeping or other approved methods. When directed, before applying bituminous material, lightly sprinkle the surface with water to control dust and ensure absorption.
- C. Application.**
 - 1. Bituminous.** The Engineer will select the application temperature within the limits recommended in Item 300, "Asphalts, Oils, and Emulsions." Apply material within 15°F of the selected temperature.

Distribute the material smoothly and evenly at the rate selected by the Engineer. When directed, roll the freshly applied prime coat with a pneumatic-tire roller to ensure penetration.
 - 2. Blotter.** Spread blotter material before allowing traffic to use a primed surface. When "Prime Coat and Blotter" is shown on the plans as a bid item, apply blotter material to primed surface at the

310.5 to 314.4

rate shown in the plans or as directed. When “Prime Coat” is shown on the plans as a bid item, apply blotter to spot locations or as directed to accommodate traffic movement through the work area. Remove blotter material before placing the surface. Dispose of blotter material according to applicable state and federal requirements.

310.5. Measurement. This Item will be measured by the gallon of bituminous material placed and accepted.

310.6. Payment. The work performed and materials furnished in accordance with this Item and measured as provided under “Measurement” will be paid for at the unit price bid for “Prime Coat” or “Prime Coat and Blotter” of the type and grade of bituminous material specified. This price is full compensation for cleaning and sprinkling the area to be primed; materials, including blotter material; and rolling, equipment, labor, tools, and incidentals.

ITEM 314

EMULSIFIED ASPHALT TREATMENT

314.1. Description. Apply an emulsified asphalt and water mixture as a base or subgrade treatment; for erosion control, including dust prevention; or as a prime coat.

314.2. Materials. Furnish materials in accordance with the following:

- Item 204, “Sprinkling”
- Item 300, “Asphalts, Oils, and Emulsions.”

Use emulsified asphalt of the type and grade shown on the plans. Use a quantity of emulsified asphalt in the mixture, expressed as a percent of total volume, in accordance with the percentage shown on the plans or as directed.

314.3. Equipment. Provide a self-propelled sprinkler in accordance with Article 204.3, “Equipment.” Provide calibration documentation for the tank used for distribution.

314.4. Construction. Agitate the water and emulsified asphalt to produce a uniform blend. Evenly distribute at the rate selected by the Engineer to locations shown on the plans or as directed.

- A. Base or Subgrade Treatment.** Treat the base or subgrade to the depth and width shown on the plans or as directed.

Regulate the percentage of emulsified asphalt in the mixture and distribute successive applications to achieve the specified rate. Maintain the proper moisture content of the treated material. Mix the treated material, then shape and compact as required by the specification for the course. Finish the course to the line, grade, and typical section shown on the plans. While curing the course, maintain the surface with light applications of the emulsified asphalt mixture, as directed.

- B. Erosion Control.** Apply the mixture as shown on the plans or as directed.

- C. Prime Coat.** Regulate the percentage of emulsified asphalt in the mixture and distribute successive applications to achieve the specified rate.

314.5. Measurement. The treatment will be measured by the gallon of emulsified asphalt used in the emulsified asphalt and water mixture.

314.6. Payment. The work performed and materials furnished in accordance with this Item and measured as provided under “Measurement” will be paid for at the unit price bid for “Emulsified Asphalt (Base or Subgrade Treatment),” “Emulsified Asphalt (Erosion Control),” or “Emulsified Asphalt (Prime Coat),” of the type and grade specified. This price is full compensation for materials, including emulsified asphalt and water, and for equipment, labor, tools, and incidentals.

ITEM 315

FOG SEAL

315.1. Description. Apply an emulsified asphalt and water mixture as an aggregate loss preventative or surface seal.

315.2. Materials. Use emulsified asphalt of the type and grade shown on the plans that meet the requirements of Item 300, “Asphalts, Oils, and Emulsions.” Provide water in accordance with Article 204.2, “Materials.”

Use a quantity of emulsified asphalt in the mixture, expressed as a percentage of total volume, which meets the percentage shown on the plans or directed.

315.3 to 316.2

315.3. Equipment. Provide applicable equipment in accordance with Article 316.3, "Equipment." Furnish the necessary facilities and equipment for determining the temperature of the mixture, regulating the application rate, and securing uniformity at the junction of 2 distributor loads.

315.4. Construction. Apply the mixture when the air temperature is 60°F and above, or above 50°F and rising. Measure the air temperature in the shade away from artificial heat. The Engineer will determine when weather conditions are suitable for application.

The Engineer will select the application temperature within the limits recommended in Item 300, "Asphalts, Oils, and Emulsions." Apply the material within 15°F of the selected temperature.

Distribute material at the rate shown on the plans or as directed.

Open the treated surface to traffic when directed. When an excessive quantity of asphalt is applied, furnish and uniformly distribute clean, fine sand on the surface to blot the excess. Maintain ingress and egress as directed by applying sand to freshly sealed areas.

315.5. Measurement. This Item will be measured by the gallon of emulsified asphalt used in the emulsified asphalt and water mixture.

315.6. Payment. The work performed and the materials furnished in accordance with this Item and measured as provided under "Measurement" will be paid for at the unit price bid for "Fog Seal" of the type and grade specified. This price is full compensation for materials, equipment, labor, tools, and incidentals. Blotter sand will not be paid for directly but will be subsidiary to this Item.

ITEM 316

SURFACE TREATMENTS

316.1. Description. Construct a surface treatment consisting of 1 or more applications of a single layer of asphalt material covered with a single layer of aggregate.

316.2. Materials. Furnish materials of the type and grade shown on the plans in accordance with the following:

- Item 300, "Asphalts, Oils, and Emulsions"
- Item 302, "Aggregates for Surface Treatments."

For final surfaces, unless otherwise shown on the plans, furnish aggregate with a surface aggregate classification of “B” or better.

316.3. Equipment.

- A. Distributor.** Furnish a distributor that will apply the asphalt material uniformly at the specified rate or as directed.
1. **Transverse Variance Rate.** When a transverse variance rate is shown on the plans, ensure that the nozzles outside the wheel paths will output a predetermined percentage more of asphalt material by volume than the nozzles over the wheel paths.
 2. **Calibration.**
 - a. **Transverse Distribution.** Furnish a distributor test report, no more than 1 yr. old, documenting that the variation in output for individual nozzles of the same size does not exceed 10% when tested at the greatest shot width in accordance with Tex-922-K, Part III.
 Include the following documentation on the test report:
 - the serial number of the distributor,
 - a method that identifies the actual nozzle set used in the test, and
 - the fan width of the nozzle set at a 12-in. bar height.
 When a transverse variance rate is required, perform the test using the type and grade of asphalt material to be used on the project. The Engineer may verify the transverse rate and distribution at any time. If verification does not meet the requirements, correct deficiencies and furnish a new test report.
 - b. **Tank Volume.** Furnish a volumetric calibration and strap stick for the distributor tank in accordance with Tex-922-K, Part I.
 Calibrate the distributor within the previous 5 yr. of the date first used on the project. The Engineer may verify calibration accuracy in accordance with Tex-922-K, Part II.
 3. **Computerized Distributor.** When paying for asphalt material by weight, the Engineer may allow use of the computerized distributor display to verify application rates. Verify application rate accuracy at a frequency acceptable to the Engineer.

316.4 to 316.4

- B. Aggregate Spreader.** Use a continuous-feed, self-propelled spreader to apply aggregate uniformly at the specified rate or as directed.
- C. Rollers.** Unless otherwise shown on the plans, furnish light pneumatic-tire rollers in accordance with Item 210, "Rolling."
- D. Broom.** Furnish rotary, self-propelled brooms.
- E. Asphalt Storage and Handling Equipment.** When the plans or the Engineer allows storage tanks, furnish a thermometer in each tank to indicate the asphalt temperature continuously.
Keep equipment clean and free of leaks. Keep asphalt material free of contamination.
- F. Aggregate Haul Trucks.** Unless otherwise authorized, use trucks of uniform capacity to deliver the aggregate. Provide documentation showing measurements and calculation in cubic yards. Clearly mark the calibrated level. Truck size may be limited when shown on the plans.
- G. Digital Measuring Instrument.** Furnish a vehicle with a calibrated digital-measuring instrument accurate to ± 6 ft. per mile.

316.4. Construction.

- A. General.** Asphalt application season will be as shown on the plans. Asphalt and aggregate rates shown on the plans are for estimating purposes only. The Engineer will adjust the rates for the existing conditions.
- B. Temporary Aggregate Stockpiles.** The Engineer will approve the location of temporary aggregate stockpiles on the right of way before delivery. Place stockpiles in a manner that will not:
 - obstruct traffic or sight distance,
 - interfere with the access from abutting property, or
 - interfere with roadway drainage.Locate stockpiles a minimum of 30 ft. from roadway when possible. Sign and barricade as shown on the plans.
- C. Aggregate Furnished by the Department.** When shown on the plans, the Department will furnish aggregate to the Contractor without cost. Stockpile locations are shown on the plans.
- D. Adverse Weather Conditions.** Do not place surface treatments when, in the Engineer's opinion, general weather conditions are unsuitable. Meet the requirements for air and surface temperature shown below.
 - 1. Standard Temperature Limitations.** Apply surface treatment when air temperature is above 50°F and rising. Do not apply

surface treatment when air temperature is 60°F and falling. In all cases, do not apply surface treatment when surface temperature is below 60°F.

2. Polymer-Modified Asphalt Cement Temperature Limitations.

When using materials described in Section 300.2.B, “Polymer Modified Asphalt Cement,” apply surface treatment when air temperature is above 70°F and rising. Do not apply surface treatment when air temperature is 80°F and falling. In all cases, do not apply surface treatment when surface temperature is below 70°F.

3. Asphalt Material Designed for Winter Use. When winter asphalt application is allowed, the Engineer will approve the air and surface temperature for asphalt material application. Apply surface treatment at air and surface temperatures as directed.

E. Surface Preparation. Remove existing raised pavement markers. Repair any damage incurred by removal as directed. Remove dirt, dust, or other harmful material before sealing. When shown on the plans, remove vegetation and blade pavement edges.

F. Rock Land and Shot.

1. Definitions.

- A “rock land” is the area covered at the aggregate rate directed with 1 truckload of aggregate.
- A “shot” is the area covered by 1 distributor load of asphalt material.

2. Setting Lengths. Calculate the lengths of both rock land and shot. Adjust shot length to be an even multiple of the rock land. Verify that the distributor has enough asphalt material to complete the entire shot length. Mark shot length before applying asphalt. When directed, mark length of each rock land to verify the aggregate rate.

G. Asphalt Placement.

1. General. The maximum shot width is the width of the current transverse distribution test required under Section 316.3.A.2, “Transverse Distribution,” or the width of the aggregate spreader box, whichever is less. Adjust the shot width so operations do not encroach on traffic or interfere with the traffic control plan, as directed. Use paper or other approved material at the beginning and end of each shot to construct a straight transverse joint and to prevent overlapping of the asphalt. Unless otherwise approved, match longitudinal joints with the lane lines. The Engineer may

316.4 to 316.4

require a string line if necessary to keep joints straight with no overlapping. Use sufficient pressure to flare the nozzles fully.

Select an application temperature, as approved, in accordance with Item 300, "Asphalts, Oils, and Emulsions." Uniformly apply the asphalt material at the rate directed, within 15°F of the approved temperature, and not above the maximum allowable temperature.

2. **Limitations.** Do not apply asphalt to the roadway until:
 - traffic control methods and devices are in place as shown on the plans or as directed,
 - the loaded aggregate spreader is in position and ready to begin,
 - haul trucks are loaded with enough aggregate to cover the shot area, and
 - haul trucks are in place behind the spreader box.
3. **Nonuniform Application.** Stop application if it is not uniform due to streaking, ridging, puddling, or flowing off the roadway surface. Verify equipment condition, operating procedures, application temperature, and material properties. Determine and correct the cause of nonuniform application. If the cause is high or low emulsion viscosity, replace emulsion with material that corrects the problem.
4. **Test Strips.** The Engineer may stop asphalt application and require construction of test strips at the Contractor's expense if any of the following occurs:
 - nonuniformity of application continues after corrective action;
 - on 3 consecutive shots, application rate differs by more than 0.03 gal. per square yard from the rate directed; or
 - any shot differs by more than 0.05 gal. per square yard from the rate directed.

The Engineer will approve the test strip location. The Engineer may require additional test strips until surface treatment application meets specification requirements.

- H. **Aggregate Placement.** As soon as possible, apply aggregate uniformly at the rate directed without causing the rock to roll over.
- I. **Rolling.** Start rolling operation on each shot as soon as aggregate is applied. Use sufficient rollers to cover the entire mat width in 1 pass, i.e., 1 direction. Roll in a staggered pattern. Unless otherwise shown on the plans, make a minimum of:

- 5 passes or
- 3 passes when the asphalt material is an emulsion.

If rollers are unable to keep up with the spreader box, stop application until rollers have caught up, or furnish additional rollers. Keep roller tires asphalt-free.

- J. Patching.** Before rolling, repair spots where coverage is incomplete. Repair can be made by hand spotting or other approved method. When necessary, apply additional asphalt material to embed aggregate.
- K. Brooming.** After rolling, sweep as soon as aggregate has sufficiently bonded to remove excess.
- L. Final Acceptance.** Maintain surface treatment until the Engineer accepts the work. Repair any surface failures. Before final project acceptance, remove all temporary stockpiles and restore the area to the original contour and grade.

316.5. Measurement.

- A. Asphalt Material.** Unless otherwise shown on the plans, asphalt material will be measured by one of the following methods:
- 1. Volume.** Asphalt material will be measured at the applied temperature by strapping the tank before and after road application and determining the net volume in gallons from the distributor's calibrated strap stick. The quantity to be measured for payment will be the number of gallons used, as directed, in the accepted surface treatment.
 - 2. Weight.** Asphalt material will be measured in tons using certified scales meeting the requirements of Item 520, "Weighing and Measuring Equipment," unless otherwise approved. The transporting truck must have a seal attached to the draining device and other openings. The Engineer may require random checking on public scales at the Contractor's expense to verify weight accuracy.
- Upon work completion or temporary suspension, any remaining asphalt material will be weighed by a certified public weigher, or measured by volume in a calibrated distributor or tank and the quantity converted to tons at the measured temperature. The quantity to be measured will be the number of tons received minus the number of tons remaining after all directed work is complete and minus the amount used for other items.

316.6 to 318.2

- B. Aggregate.** Aggregate will be measured by the cubic yard in the trucks as applied on the road. The Engineer may require loaded aggregate to be struck off for accurate measurement.
- C. Loading, Hauling, and Distributing Aggregate.** When the Department furnishes the aggregate, the loading, hauling, and distributing will be measured by the cubic yard in the trucks as applied on the road.

316.6. Payment. The work performed and materials furnished in accordance with this Item and measured as provided under “Measurement” will be paid for at the unit prices bid for “Asphalt,” “Aggregate,” and “Loading, Hauling, and Distributing Aggregate” of the types—grades specified. These prices are full compensation for surface preparation; furnishing, preparing, hauling, and placing materials; removing existing pavement markers and excess aggregate; rolling; cleaning up stockpiles; and equipment, labor, tools, and incidentals.

ITEM 318

HOT ASPHALT-RUBBER SURFACE TREATMENTS

318.1. Description. Construct a surface treatment consisting of 1 or more applications of a single layer of hot asphalt-rubber (A-R) binder covered with a single layer of aggregate.

318.2. Materials.

- A. Asphalt-Rubber Binder.** Furnish Type II or Type III A-R binder in accordance with Section 300.2.I, “Asphalt-Rubber Binders,” as shown on the plans. Furnish a blend design for approval. Include in the design, at a minimum, the following:
- manufacturer and grade of asphalt cement;
 - manufacturer and grade of crumb rubber;
 - manufacturer, type, and percentage of extender oil, if used;
 - test report on crumb rubber gradation in accordance with Tex-200-F, Part I;
 - design percentage of crumb rubber versus asphalt content;
 - blending temperature; and
 - test results on the properties at reaction times of 60, 90, 240, 360, and 1,440 min. in accordance with Section 300.2.I, “Asphalt-Rubber Binders.”

Furnish a new blend design if the grade or source for any of the components changes.

- B. Tack Coat.** Unless otherwise shown on the plans or approved, furnish CSS-1H, SS-1H, or a performance grade (PG) binder with a minimum high temperature grade of PG 58 for tack coat binder in accordance with Item 300, “Asphalts, Oils, and Emulsions.” Do not dilute emulsified asphalts at the terminal, in the field, or at any other location before use. If required, verify that emulsified asphalt proposed for use meets the minimum residual asphalt percentage specified in Item 300.
- C. Aggregate.** Furnish aggregate meeting Item 302, “Aggregates for Surface Treatments,” of the type and grade shown on plans. For final surfaces, unless otherwise shown on the plans, furnish aggregate with a minimum B surface aggregate classification.

318.3. Equipment.

- A. Distributor.** Furnish a distributor calibrated in accordance with Article 316.3, “Equipment,” capable of keeping the rubber in uniform suspension and adequately mixing the asphalt, rubber, and any additional additives. If equipped with an onboard scale system or micro-motion meters for proportioning or payment, they must weigh or measure the load within a 0.4% accuracy in accordance with Item 520, “Weighing and Measuring Equipment.”
- B. Aggregate Spreader.** Use a continuous-feed, self-propelled spreader to apply aggregate uniformly at the specified rate or as directed.
- C. Rollers.** Unless otherwise shown on the plans, furnish medium pneumatic rollers in accordance with Item 210, “Rolling.”
- D. Broom.** Furnish rotary self-propelled power brooms.
- E. Asphalt Storage and Handling Equipment.** Furnish a recording thermometer in each tank to indicate the asphalt temperature continuously. Keep equipment clean and free of leaks.
- F. Hot Asphalt-Rubber Blending and Storage Equipment.** Provide a mechanical blender for proper proportioning and thorough mixing of the asphalt and rubber. Use proportioning, weighing, and measuring devices meeting the requirements of Item 520, “Weighing and Measuring Equipment.” If an A-R binder storage tank is used, equip it with:
 - a heating system to maintain the proper temperature of the binder,
 - recording thermometer in each tank to indicate the asphalt-rubber binder temperature continuously,

318.4 to 318.4

- an internal mixing unit capable of maintaining a homogeneous mixture of asphalt and rubber, and
- a sampling port.

Keep A-R binder free of contamination.

- G. Aggregate Haul Trucks.** Unless otherwise authorized, use trucks of uniform capacity to deliver the aggregate. Provide documentation showing measurements and calculation in cubic yards. Clearly mark the calibrated level. Truck size may be limited when shown on the plans.
- H. Digital Measuring Instrument.** Furnish a vehicle with a calibrated, digital measuring instrument, accurate to ± 6 ft. per mile.
- I. Truck Scales.** Provide standard platform scales in accordance with Item 520, "Weighing and Measuring Equipment." Truck scales will not be required if the distributor has an adequate calibrated scale system.
- J. Aggregate Heating System.** If required, furnish a heating system that will:
- heat aggregate to the specified temperature,
 - not damage aggregate,
 - not leave fuel residue on heated aggregate, and
 - provide a continuous recording thermometer to indicate aggregate temperature as it leaves the system.

318.4. Construction.

- A. General.** Asphalt application season will be as shown on the plans. Asphalt and aggregate rates shown on the plans are for estimating purposes only. The Engineer will adjust the rates for the existing conditions.
- B. Temporary Aggregate Stockpile.** The Engineer will approve the location of temporary aggregate stockpiles on the right of way before delivery. Place stockpiles in a manner that will not:
- obstruct traffic or sight distance,
 - interfere with the access from abutting property, or
 - interfere with roadway drainage.
- Locate stockpiles a minimum of 30 ft. from the roadway when possible. Sign and barricade as shown on the plans.
- C. Department-Furnished Aggregate.** When shown on the plans, the Department will furnish aggregate to the Contractor without cost. Stockpile locations will be shown on the plans.

D. Adverse Weather Conditions. Do not place hot asphalt-rubber surface treatment when, in the Engineer's opinion, general weather conditions are unsuitable. Apply surface treatment when the air temperature is 80°F and above, or above 70°F and rising. In all cases, do not apply surface treatment when surface temperature is below 70°F.

E. Mixing Hot A-R Binder. Mix in accordance with the approved blend design required in Section 318.2.A, "Asphalt-Rubber Binder."

At the end of each shift, provide the Engineer with production documentation, which includes the following:

- amount and temperature of asphalt cement before addition of rubber,
- amount of rubber and any extender added,
- viscosity of each hot A-R batch just before roadway placement, and
- time of the rubber additions and viscosity tests.

F. Surface Preparation. Remove existing raised pavement markers in accordance with the plans. Remove dirt, dust, or other harmful material. When directed by the Engineer, apply a tack coat before applying the hot asphalt-rubber treatment on an existing wearing surface in accordance with Section 340.4.G.2, "Tack Coat."

G. Rock Land and Shot.

1. Definitions.

- A "rock land" is the area covered at the aggregate rate, as directed, with 1 truckload of aggregate.
- A "shot" is the area covered by 1 distributor load of asphalt material.

2. Setting Lengths. Calculate the lengths of each. Adjust shot length to be an even multiple of the rock land. Verify that the distributor has enough asphalt material to complete entire shot length. Mark shot length before applying hot A-R. When directed, mark length of each rock land to verify the aggregate rate.

H. Hot A-R Binder Placement.

1. General. Adjust the application temperature, not exceeding 425°F, to obtain the proper application characteristics. Uniformly apply at the rate specified or as directed.

The maximum shot width is 13 ft. Adjust the shot width as directed so operations do not encroach on traffic or interfere with the traffic control plan. Use paper or other approved material at the beginning and end of each shot to construct a straight transverse joint and to

318.4 to 318.4

prevent overlapping of the asphalt. Unless otherwise approved, longitudinal joints must match lane lines.

2. **Limitations.** Do not apply asphalt to the roadway until:
 - traffic control methods and devices are in place as shown on the plans or as directed,
 - the loaded aggregate spreader is in position and ready to begin,
 - haul trucks are loaded with enough aggregate to cover the shot area, and
 - haul trucks are in place behind the spreader box.
 3. **Test Sections.** Place a test section at an approved location to demonstrate that equipment is capable of uniformly mixing and placing the A-R binder. The Engineer may stop work at any time and require additional test sections to be shot if:
 - the application is not uniform;
 - on 3 consecutive shots, application rate differs by more than 0.03 gal. per square yard from the rate directed; or
 - any shot differs by more than 0.05 gal. per square yard from the rate directed.
 4. **Nonuniform Application.** Stop application if not uniform due to streaking, ridging, puddling, or flowing off the roadway surface. Verify equipment condition, operating procedures, application temperature, and material properties. Determine the cause of nonuniform application and correct it.
- I. Aggregate Placement.** The aggregate must be surface dry before application. When shown on the plans, preheat aggregate to between 250°F and 350°F. Cover each load with tarping material to minimize the temperature drop of the preheated aggregate. Immediately after the distributor has started spraying the hot asphalt-rubber, uniformly apply the aggregate at the rate specified by the Engineer.
- J. Rolling.** Start the rolling operation on each shot as soon as aggregate is applied. Use sufficient rollers to cover entire mat width in 1 pass (1 direction). Roll in a staggered pattern. Unless otherwise shown on the plans, make at least 5 passes.
- If rollers are unable to keep up with spreader box, stop application until rollers have caught up, or furnish additional rollers. Keep roller tires free of asphalt.

- K. Repair.** Repair areas where coverage is incomplete. Make repairs by patching, hand spotting, or other method, as approved. When necessary, apply additional hot A-R binder to embed the aggregate.
- L. Brooming.** After rolling, sweep away excess as soon as aggregate has sufficiently bonded.
- M. Final Acceptance.** Maintain surface treatment until the Engineer accepts the work. Repair any surface failures. Before final project acceptance, remove all temporary stockpiles and restore the area to the original contour and grade.

318.5. Measurement.

- A. A-R Binder.** A-R binder, including all components, will be measured in tons just before delivery to the point of application.
- B. Aggregate.** Contractor-supplied aggregate will be measured by the cubic yard in the trucks as applied to the road.
- C. Loading, Hauling, and Distributing Aggregate.** If the Department furnishes the aggregate, the loading, hauling, and distributing will be measured by the cubic yard in the trucks as applied on the road.

318.6. Payment. The work performed and materials furnished in accordance with this Item and measured as provided under “Measurement” will be paid for at the unit prices bid for “A-R Binder” of the type specified; “Aggregate” of the type, grade and surface aggregate classification specified; or “Loading, Hauling, and Distributing Aggregate.” These prices are full compensation for surface preparation, tack coat, heating and mixing, hauling and placing all materials, rolling and removing excess aggregate, cleaning up stockpiles, test sections, equipment, labor, tools, and incidentals.

ITEM 320

EQUIPMENT FOR ASPHALT CONCRETE PAVEMENT

320.1. Description. Provide equipment to produce, haul, place, compact, and core asphalt concrete pavement.

320.2. Equipment. Ensure weighing and measuring equipment complies with Item 520, “Weighing and Measuring Equipment.” Synchronize equipment to produce a mixture meeting the required proportions.

A. Production Equipment. Provide:

- drum-mix type, weigh-batch, or modified weigh-batch mixing plants that ensure a uniform, continuous production;
- automatic proportioning and measuring devices with interlock cut-off circuits that stop operations if the control system malfunctions;
- visible readouts indicating the weight or volume of asphalt and aggregate proportions;
- safe and accurate means to take required samples by inspection forces;
- permanent means to check the output of metering devices and to perform calibration and weight checks; and
- additive-feed systems to ensure a uniform, continuous material flow in the desired proportion.

1. Drum-Mix Plants. Provide a mixing plant that complies with the requirements below.

a. Aggregate Feed System. Provide:

- a minimum of 1 cold aggregate bin for each stockpile of individual materials used to produce the mix;
- bins designed to prevent overflow of material;
- scalping screens or other approved methods to remove any oversized material, roots, or other objectionable materials;
- a feed system to ensure a uniform, continuous material flow in the desired proportion to the dryer;
- an integrated means for moisture compensation;
- belt scales, weigh box, or other approved devices to measure the weight of the combined aggregate; and
- cold aggregate bin flow indicators that automatically signal interrupted material flow.

b. Reclaimed Asphalt Pavement (RAP) Feed System. Provide a separate system to weigh and feed RAP into the hot mix plant.

c. Mineral Filler Feed System. Provide a closed system for mineral filler that maintains a constant supply with minimal loss of material through the exhaust system. Interlock the measuring device into the automatic plant controls to automatically adjust the supply of mineral filler to plant production and provide a consistent percentage to the mixture.

- d. Heating, Drying, and Mixing Systems.** Provide:
- a dryer or mixing system to agitate the aggregate during heating;
 - a heating system that controls the temperature during production to prevent aggregate and asphalt binder damage;
 - a heating system that completely burns fuel and leaves no residue; and
 - a recording thermometer that continuously measures and records the mixture discharge temperature.
- e. Asphalt Binder Equipment.** Supply equipment to heat binder to the required temperature. Equip the heating apparatus with a continuously recording thermometer located at the highest temperature point. Produce a 24-hr. chart of the recorded temperature. Place a device with automatic temperature compensation that accurately meters the binder in the line leading to the mixer.
- Furnish a sampling port on the line between the storage tank and mixer. Supply an additional sampling port between any additive blending device and mixer.
- f. Mixture Storage and Discharge.** Provide a surge-storage system to minimize interruptions during operations unless otherwise approved. Furnish a gob hopper or other device to minimize segregation in the bin. Provide an automated system that weighs the mixture upon discharge and produces a ticket showing:
- date,
 - project identification number,
 - plant identification,
 - mix identification,
 - vehicle identification,
 - total weight of the load,
 - tare weight of the vehicle,
 - weight of mixture in each load, and
 - load number or sequential ticket number for the day.
- g. Truck Scales.** Provide standard platform scales at an approved location.
- 2. Weigh-Batch Plants.** Provide a mixing plant that complies with Section 320.2.A.1, "Drum-Mix Plants," except as required below.

320.2 to 320.2

- a. **Screening and Proportioning.** Provide enough hot bins to separate the aggregate and to control proportioning of the mixture type specified. Supply bins that discard excessive and oversized material through overflow chutes. Provide safe access for inspectors to obtain samples from the hot bins.
 - b. **Aggregate Weigh Box and Batching Scales.** Provide a weigh box and batching scales to hold and weigh a complete batch of aggregate. Provide an automatic proportioning system with low bin indicators that automatically stop when material level in any bin is not sufficient to complete the batch.
 - c. **Asphalt Binder Measuring System.** Provide bucket and scales of sufficient capacity to hold and weigh binder for 1 batch.
 - d. **Mixer.** Equip mixers with an adjustable automatic timer that controls the dry and wet mixing period and locks the discharge doors for the required mixing period. Furnish a pug mill with a mixing chamber large enough to prevent spillage.
3. **Modified Weigh-Batch Plants.** Provide a mixing plant that complies with Section 320.2.A.2, "Weigh-Batch Plants," except as specifically described below.
 - a. **Aggregate Feeds.** Aggregate control is required at the cold feeds. Hot bin screens are not required.
 - b. **Surge Bins.** Provide 1 or more bins large enough to produce 1 complete batch of mixture.
- B. **Hauling Equipment.** Provide trucks with enclosed sides to prevent asphalt mixture loss. Cover each load of mixture with waterproof tarpaulins. Before use, clean all truck beds to ensure the mixture is not contaminated. When necessary, coat the inside truck beds with an approved release agent from the list maintained by the Construction Division.
- C. **Placement and Compaction Equipment.** Provide equipment that does not damage underlying pavement. Comply with laws and regulations concerning overweight vehicles. When permitted, other equipment that will consistently produce satisfactory results may be used.
 1. **Asphalt Paver.** Furnish a paver that will produce a finished surface that meets longitudinal and transverse profile, typical section, and placement requirements. Ensure the paver does not support the weight of any portion of hauling equipment other than the connection. Provide loading equipment that does not transmit

vibrations or other motions to the paver that adversely affect the finished pavement quality. Equip the paver with an automatic, dual, longitudinal-grade control system and an automatic, transverse-grade control system.

- a. **Tractor Unit.** Supply a tractor unit that can push or propel vehicles, dumping directly into the finishing machine to obtain the desired lines and grades to eliminate any hand finishing. Equip the unit with a hitch sufficient to maintain contact between the hauling equipment's rear wheels and the finishing machine's pusher rollers while mixture is unloaded.
 - b. **Screed.** Provide a heated compacting screed that will produce a finished surface that meets longitudinal and transverse profile, typical section, and placement requirements. Screed extensions must provide the same compacting action and heating as the main unit unless otherwise approved.
 - c. **Grade Reference.** Provide a grade reference with enough support that the maximum deflection does not exceed 1/16 in. between supports. Ensure that the longitudinal controls can operate from any longitudinal grade reference including a string line, ski, mobile string line, or matching shoes. Furnish paver skis or mobile string line at least 40 ft. long unless otherwise approved.
2. **Material Transfer Devices.** Provide the specified type of device when shown on the plans. Ensure the devices provide a continuous, uniform mixture flow to the asphalt paver. When used, provide windrow pick-up equipment constructed to pick up substantially all roadway mixture placed in the windrow.
 3. **Remixing Equipment.** When required, provide equipment that includes a pug mill, variable pitch augers, or variable diameter augers operating under a storage unit with a minimum capacity of 8 tons.
 4. **Motor Grader.** When allowed, provide a self-propelled grader with a blade length of at least 12 ft. and a wheelbase of at least 16 ft.
 5. **Handheld Infrared Thermometer.** Provide a handheld infrared thermometer meeting the requirements of Tex-244-F.
 6. **Rollers.** Provide rollers meeting the requirements of Item 210, "Rolling," for each type of roller required for compaction.

320.3 to 330.2

7. **Straightedges and Templates.** Furnish 10-ft. straightedges and other templates as required or approved.
- D. **Field Laboratory.** Unless otherwise shown on the plans, provide and maintain a Type D Structure (Asphalt Mix Control Laboratory) in accordance with Item 504, "Field Office and Laboratory," and details shown on the plans.
- E. **Coring Equipment.** When coring is required, provide equipment suitable to obtain a pavement specimen meeting the dimensions for testing.

320.3. Measurement and Payment. The work performed, materials furnished, equipment, labor, tools, and incidentals will not be measured or paid for directly, but will be subsidiary to pertinent Items.

ITEM 330

LIMESTONE ROCK ASPHALT PAVEMENT

330.1. Description. Construct a base course, a surface course, a level-up course, or any combination of these courses of the types and grades shown on the plans using a cold mixed material consisting of native limestone rock asphalt (LRA) aggregate, fluxing material, water, and when specified, additives and virgin aggregates.

330.2. Materials. Type I LRA mixture consists entirely of native LRA aggregate, flux material, water, and additives. Type II LRA mixture consists of a blend of native LRA aggregate, virgin aggregates, fluxing material, additives, and water. Furnish uncontaminated materials of uniform quality that meet the requirements of the plans and specifications.

Notify the Engineer of all materials sources. Notify the Engineer before changing any material source or formulation. When making a source or formulation change, the Engineer will verify that the specification requirements are met and may require a new laboratory mixture design, trial batch, or both. The Engineer may sample and test project materials at any time throughout the duration of the project to assure specification compliance.

- A. **Aggregate.** Furnish aggregates from sources that conform to the requirements shown in Table 1, and as specified in this Section, unless otherwise shown on the plans. Provide aggregate stockpiles that meet the definition in this Section for either a coarse aggregate or fine aggregate. Supply mechanically crushed gravel or stone aggregates that

meet the definitions in Tex-100-E. The Engineer will designate the plant or the quarry as the sampling location. Samples must be from materials produced for the project. The Engineer will establish the surface aggregate classification (SAC) and perform Los Angeles abrasion, magnesium sulfate soundness, and Micro-Deval tests. Perform all other aggregate quality tests listed in Table 1. Document all test results. The Engineer may run tests on independent or split samples to verify Contractor test results. Stockpile aggregates for each source and type separately.

1. **Coarse Aggregate.** Coarse aggregate stockpiles must have no more than 20% material passing the No. 10 sieve. Provide aggregates from sources listed in the Department's *Bituminous Rated Source Quality Catalog* (BRSQC). Provide nonlisted sources only when tested by the Engineer and approved before use. Allow 30 calendar days for the Engineer to sample, test, and report results for nonlisted sources.

Provide coarse aggregate with a minimum SAC as shown on the plans. SAC requirements apply only to aggregates used on the surface of travel lanes, unless otherwise shown on the plans. The SAC for sources on the Department's Aggregate Quality Monitoring Program (AQMP) is listed in the BRSQC.

When a Type II LRA mixture is specified, Class B aggregate may be blended with Class A aggregate in order to meet requirements for Class A materials. When blending Class A and B aggregates to meet a Class A requirement, ensure that at least 50% by weight of the material retained on the No. 4 sieve comes from the Class A aggregate source. Blend virgin aggregate with native LRA aggregate in the percentages shown in Table 4. When blending, do not use Class C aggregates.

- a. **LRA Aggregate.** Native LRA aggregate consists of limestone impregnated with naturally occurring asphalt. LRA aggregates that contain less than 1% of naturally occurring asphalt are defined as white rock. Each aggregate source proposed for use will be sampled and tested to determine compliance with Table 1 requirements before the addition of fluxing material, additives, and water.
- b. **Virgin Aggregate.** Provide virgin aggregates that meet the requirements of Table 1. Each aggregate source proposed for use will be sampled and tested to determine compliance with

330.2 to 330.2

Table 1 requirements before the addition of fluxing material, additives, and water.

2. **Fine Aggregate.** Fine aggregate stockpiles must have no more than 30% material retained on the No. 10 sieve. Supply fine aggregates that are free from organic impurities. The Engineer may test the fine aggregate in accordance with Tex-408-A to verify that the material is free from organic impurities. Use only fine aggregates generated by the production and handling of LRA or the virgin coarse aggregate. Use LRA fine aggregate that has a naturally impregnated bitumen content of 5.0 to 8.5% when tested in accordance with Tex-236-F.

If 10% or more of the stockpile is retained on the No. 4 sieve, test the stockpile and verify that it meets the requirements in Table 1 for Coarse Aggregate Angularity (Tex-460-A) and Flat and Elongated Particles (Tex-280-F).

Table 1
Aggregate Quality Requirements

Property	Test Method	Requirement	
		Native LRA Aggregate	Virgin Aggregate
Coarse Aggregate			
SAC	AQMP	B or C as shown on the plans	A
Deleterious material, %, Max	Tex-217-F, Part I	1.5	1.5
Decantation, %, Max	Tex-217-F, Part II	N/A	1.5
Micro-Deval abrasion, %, Max	Tex-461-A	Note 1	Note 1
Los Angeles abrasion, %, Max	Tex-410-A	40	25
Magnesium sulfate soundness, 5 cycles, %, Max	Tex-411-A	30	25
Coarse aggregate angularity, 2 crushed faces, %, Min	Tex-460-A, Part I	N/A	85 ²
Flat and elongated particles @ 5:1, %, Max	Tex-280-F	N/A	10
Combined Aggregate³			
Naturally impregnated bitumen content, total combined gradation, % by wt.	Tex-236-F	5.0 to 8.5	N/A

1. Not used for acceptance purposes. Used by the Engineer as an indicator of the need for further investigation.
2. Unless otherwise shown on the plans. Only applies to crushed gravel.
3. Aggregates, without added mineral filler or additives, combined as used in the job mix formula (JMF).

B. Asphalt Material.

1. **Fluxing Material.** Provide fluxing material, composed of flux oil (a blend of asphalt and oil) or a blend of flux oil and aromatic oil meeting the requirements of Table 2. When required by the Engineer, provide a test report showing that the fluxing material meets the requirements of Table 2. Use fluxing material in the paving mixture to meet the workability requirements of Section 330.4.E, "Mixing."

Table 2
Fluxing Material Properties

Property	Material	Flux Oil		Aromatic Oil	
	Test Procedure	Min	Max	Min	Max
Kinematic viscosity, 140°F, cSt	T 201	60	200	–	150
Loss on heating, % by wt.	T 47	–	10	–	12
Water, %	T 55	–	0.2	–	0.2
Flash point, C.O.C., °F	T 48	200	–	135	–

2. **Water.** Provide water that meets the requirements of Item 204, “Sprinkling.”
3. **Tack Coat.** Unless otherwise shown on the plans or approved, furnish CSS-1H, SS-1H, or a performance-graded (PG) binder with a minimum high-temperature grade of PG 58 for tack coat binder in accordance with Item 300, “Asphalts, Oils, and Emulsions.” Do not dilute emulsified asphalts at the terminal, in the field, or at any other location before use. If required, verify that emulsified asphalt proposed for use meets the minimum residual asphalt percentage specified in Item 300.

The Engineer will obtain at least 1 sample of the tack coat per project and test the sample for specification compliance. The Engineer will obtain the sample from the asphalt distributor, immediately before use.

- C. **Additives.** When shown on the plans, use the type and rate of additive specified. Other additives that facilitate mixing or improve the quality of the mixture may be allowed when approved. Approved additives must be listed in the Quality Control Plan (QCP) as specified in Article 330.4, “Construction.”

If lime is specified or selected for use as an antistripping agent, add only to the virgin aggregate in accordance with Item 301, “Asphalt Antistripping Agents.” If a liquid antistripping agent is used, add in accordance with Item 301. Do not add lime directly into the mixing drum of any plant where lime is removed through the exhaust stream, unless the plant has a baghouse or dust collection system that re-introduces the lime back into the drum.

330.3. Equipment. Provide required or necessary equipment in accordance with Item 320, “Equipment for Asphalt Concrete Pavement.” Use either weigh-batch or continuous mixing plants. The following requirements are modifications or additions to those in Item 320.

A. Weigh-Batch Plants.

1. **Screening and Proportioning.** Provide a sufficient number of bins as specified in Article 330.4, "Construction."
2. **Fluxing Material Measuring System.** Provide a fluxing material measuring device in the fluxing material line leading to the mixer to accurately determine the accumulated amount of fluxing material. Make permanent provisions for checking the accuracy of the meter output. Provide scales to hold and weigh flux for 1 batch.
3. **Mixer.** Equip the mixer with a spray bar that will distribute the fluxing material quickly and uniformly throughout the mixer.

B. Continuous Mixing Plants.

1. **Screening and Proportioning.** Meet the requirements of Section 330.3.A.1.a, "Screening and Proportioning." These requirements also apply to stockpiled material proposed for direct use by a continuous mixing plant without the use of plant bins.
2. **Fluxing Material Measuring System.** Place a fluxing material measuring device in the fluxing material line leading to the mixer to accurately determine the accumulated amount of fluxing material. Make permanent provisions for checking the accuracy of the meter output.
3. **Mixer.** Provide a continuous type mixer large enough to produce not less than 40 tons of mixture per hour. Equip the mixer with a spray bar that will distribute the fluxing material quickly and uniformly throughout the mixer.

330.4. Construction. Provide quality control (QC) testing as needed to meet the requirements of this Item. The Department will perform quality assurance (QA) testing.

- A. **QCP.** Develop and follow the QCP in detail. Obtain approval from the Engineer for changes to the QCP made during the project. The Engineer may suspend operations if the Contractor fails to comply with the QCP.

Submit a written QCP to the Engineer. Receive the Engineer's approval of the QCP before beginning production. Include the following items in the QCP.

1. **Project Personnel.** For project personnel, include:
 - a list of individuals responsible for quality control with authority to take corrective action and
 - contact information for each individual listed.
2. **Material Delivery and Storage.** For material delivery and storage, include:
 - the sequence of material processing, delivery, and minimum quantities to assure continuous plant operations;
 - aggregate stockpiling procedures to avoid contamination and segregation;
 - frequency, type, and timing of LRA and aggregate stockpile testing to assure conformance of material requirements before mixture production;
 - flux oil for use in the LRA mixture; and
 - aromatic oil for use in the LRA mixture.
3. **Production.** For production, include:
 - loader operation procedures to avoid contamination in cold bins;
 - the number of bins and the aggregate size to be placed in each bin for each type of LRA mixture produced;
 - procedures for calibrating and controlling cold feeds;
 - procedures to eliminate debris and oversized material;
 - procedures for adding and verifying rates of each applicable mixture component (i.e., LRA, white rock, aggregates, flux oil) to minimize the formation of flux balls;
 - procedures for LRA mixture testing to assure conformance of material requirements during production;
 - procedures for reporting job control test results; and
 - procedures to avoid segregation in the silo.
4. **Loading and Transporting.** For loading and transporting, include:
 - type and application method for release agents and
 - truck and rail car loading procedures to avoid segregation.
5. **Placement and Compaction.** For placement and compaction, include:
 - proposed arrangements for any required prepaving meetings, including dates and locations;
 - type and application method for release agents in the paver and on rollers, shovels, lutes, and other utensils;

- procedures for the transfer of mixture into the paver while avoiding segregation and preventing material spillage;
- process to balance production, delivery, paving, and compaction to achieve continuous placement operations;
- paver operations (e.g., operation of wings, height of mixture in auger chamber) to avoid physical and thermal segregation and other surface irregularities; and
- procedures to construct quality longitudinal and transverse joints.

B. Stockpiling of Aggregates and LRA. Provide a smooth and well-drained area, cleared of trash, weeds, and grass. Build stockpiles in a manner that will minimize aggregate degradation and segregation. Avoid contamination and mixing of stockpiles.

Provide LRA or aggregate stockpiles for a minimum of 2 days' production before beginning plant operations. Maintain at least a 2-day aggregate supply through the course of the project unless otherwise directed.

Stockpile aggregates for each source and type separately. Do not add material to an approved stockpile unless otherwise approved. Handle and load the LRA in a manner that prevents segregation. The Engineer may reject stockpiled materials that come in contact with the earth or other objectionable material.

In addition to the requirements listed above, the material storage and stockpile requirements must be included in the approved QCP.

- C. Storage and Heating of Fluxing Material.** Do not heat fluxing material to a temperature more than that specified by the manufacturer. Ensure that the flux material storage capacity meets the requirements of the plant.
- D. Job-Mix Formula.** Provide a job-mix formula (JMF) design report for a paving mixture that meets the requirements of Tables 3, 4, and 5. Identify in the report the combined aggregate gradation, the percentage of each material component used in the mixture, and results of all applicable tests. Obtain approval of the JMF before starting production. With approval, the JMF target values may be adjusted as needed within the percentage point tolerances of Table 6 without a laboratory redesign of the mixture. If the adjustments exceed the tolerances shown in Table 6, the Engineer may require a new mixture design. Adjustments must not exceed the master gradation for the type of mixture specified on the plans.

330.4 to 330.4

Determine the aggregate and asphalt correction factors from the ignition oven using Tex-236-F. Provide the Engineer with split samples of the mixtures and blank samples used to determine the correction factors. The Engineer will use the split samples provided by the Contractor to determine the aggregate and asphalt correction factors for the ignition oven in accordance with Tex-236-F.

If the aggregate mineralogy is such that Tex-236-F does not yield reliable results, the Engineer may allow alternate methods for determining the asphalt content and aggregate gradation. Unless otherwise allowed, the Engineer will require the Contractor to provide evidence that results from Tex-236-F are not reliable before permitting an alternate method. If an alternate test method is allowed, use the applicable test procedure as directed.

**Table 3
Master Grading per Tex-200-F, Part I, % Retained by Weight**

Sieve Size	Type I						Type II			
	Grade						Grade			
	AA Coarse Base	A Medium Base	B Fine Base	C Course Surface	CC Medium Surface	D Fine Surface	BS Surface	CS Medium Surface	DS Fine Surface	FS Thin Surface
1-1/2"	0	—	—	—	—	—	—	—	—	—
1-1/4"	0-10	—	—	—	—	—	—	—	—	—
1"	—	0	—	—	—	—	—	—	—	—
7/8"	15-30	0-2	—	—	—	—	—	—	—	—
3/4"	—	—	—	—	—	—	0	—	—	—
5/8"	—	5-15	0	—	—	—	0-2	0	—	—
1/2"	—	—	0-2	0	0	—	0-10	0-2	0	—
3/8"	25-45	25-35	5-15	0-2	0-2	0	10-25	0-10	0-2	0
1/4"	—	—	—	—	—	0-2	—	—	—	—
#4	45-60	50-60	45-60	35-50	35-50	10-25	40-55	35-55	10-25	0-15
#10	60-75	65-75	60-75	65-80	50-65	50-65	60-75	60-75	50-65	35-60

Table 4
Mixture Components % by Weight

Mixture Component	Type I						Type II			
	Grade						Grade			
	AA Coarse Base	A Medium Base	B Fine Base	C Course Surface	CC Medium Surface	D Fine Surface	BS Surface	CS Medium Surface	DS Fine Surface	FS Thin Surface
White rock ¹	N/A	15–35	15–35	15–35	15–35	15–35	15–35	15–35	15–35	N/A
LRA	96–98	96–98	96–98	96–98	96–98	96–98	72–80.5	72–80.5	72–80.5	36.5–63.5
Virgin aggregate	N/A	N/A	N/A	N/A	N/A	N/A	18–25	18–25	18–25	35–60
Flux material	2.0–4.0	2.0–4.0	2.0–4.0	2.0–4.0	2.0–4.0	2.0–4.0	1.5–3.0	1.5–3.0	1.5–3.0	1.5–3.5

1. White rock values are given as a percentage of total LRA aggregate.

Table 5
Mixture Properties

Property	Test Method	Requirement
Hveem stability, min	Tex-208-F	35 ¹
Laboratory-molded density, %	Tex-207-F	89.0 ±2
Theoretical maximum specific gravity of bituminous mixtures	Tex-227-F	N/A
Bitumen content, % by wt.	Tex-236-F	6.5 to 11.0
Water and light hydrocarbon volatiles, %, max	Tex-212-F, Part II	5.5
Boil test, %	Tex-530-C	10 ²

1. Cease operations if 2 consecutive tests fail. The Engineer may waive this requirement if other information indicates that the next material to be produced will meet the minimum value specified.

2. May be increased or eliminated when directed by the Engineer.

Table 6
Deviations from Current JMF Target Values

Material	Test Method	Tolerance
Individual % retained for #10 sieves and larger	Tex-200-F	±5.0
Individual % retained for sieves smaller than #10 and larger than #200		±3.0
% passing the #200 sieve		±2.0
Fluxing material, %	Determined from quantity used	±0.2

E. Mixing. Produce all LRA mixtures in the same mixing plant, unless otherwise approved. When needed, mix aromatic oil into the mixing chamber independently of the fluxing material. The aromatic oil may not exceed 35% of the total weight of the combined fluxing material and aromatic oil used in the paving mixture.

The Engineer will not accept mixtures produced when the LRA aggregate or virgin aggregate contains moisture above the saturated

330.4 to 330.4

surface dry condition. Inspect for visual surface moisture on the aggregates or any unusual quantities of fines clinging to the coarse aggregate.

Mix the materials at a central mixing plant and ship ready to use. Add water when necessary to improve workability of the mixture. Ensure that the mixture leaves the plant in a workable condition. The Engineer may reject mixtures that do not remain workable for a period that is sufficient to permit loading, unloading, hauling, placing, and compacting. Provide materials that remain workable in a stockpile for at least 6 months.

- F. Hauling Operations.** Transport the LRA mixture to the project or delivery point in trucks or rail cars as needed. Before use, clean all truck beds or rail cars to ensure mixture is not contaminated. When a release agent is necessary, use a release agent on the approved list maintained by the Construction Division to coat truck beds and inside rail cars. Waterproof tarpaulins are not required to cover loads.
- G. Placement Operations.** Prepare the surface by removing raised pavement markers and objectionable material such as moisture, dirt, sand, leaves, and other loose impediments from the surface before placing mixture. Remove vegetation from pavement edges. Place the mixture to meet the typical section requirements and produce a smooth, finished surface with a uniform appearance and texture. Offset longitudinal joints of successive courses of mixture by at least 6 in. Place mixture so longitudinal joints on the surface course coincide with lane lines, or as directed. Ensure that all finished surfaces will drain properly.

Unless otherwise shown on the plans, the asphalt mixture may be dumped in a windrow and then placed in the finishing machine with windrow pickup equipment. Prevent the windrow pickup equipment from contaminating the mixture.

After placing the paving mixture, defer compaction, as directed by the Engineer, to allow for volatilization. When placing more than 1 pavement course, allow the previous course to dry and cure before placing the next course. Unless otherwise directed, the course will be considered cured if the hydrocarbon volatile content of the mixture is 0.4% or less by weight of the mixture when tested according to Tex-213-F.

When shown on the plans or as approved, a motor grader may be used to spread the mixture. Thoroughly aerate the mixture and spread into

place with a power motor grader in a uniform layer. Placement in narrow strips or small irregular areas may require hand spreading.

1. **Weather Conditions.** Place the mixture when the roadway surface temperature is 60°F or higher unless otherwise approved. Place the mixture only when the weather conditions and moisture conditions of the roadway surface are suitable in the opinion of the Engineer.
 2. **Tack Coat.** Clean the surface before placing the tack coat. Unless otherwise approved, apply tack coat uniformly at the rate directed by the Engineer. The Engineer will set the rate between 0.04 and 0.10 gal. of residual asphalt per square yard of surface area. Apply a thin, uniform tack coat to all contact surfaces of curbs, structures, and joints. Prevent splattering of the tack coat when placed adjacent to curb, gutter, and structures. Roll the tack coat with a pneumatic-tire roller when directed. The Engineer may use Tex-243-F to verify that the tack coat has adequate adhesive properties. The Engineer may suspend paving operations until there is adequate adhesion.
- H. Compaction.** Furnish the type, size, and number of rollers required for compaction, as approved. Furnish at least 1 medium pneumatic-tire roller (minimum 12-ton weight). Use Tex-207-F, Part IV, to establish rolling patterns that achieve maximum compaction. Follow the selected rolling pattern unless changes that affect compaction occur in the mixture or placement conditions. When such changes occur, establish a new rolling pattern. Compact the pavement to the cross section of the finished paving mixture meeting the requirements of the plans and specifications. Unless otherwise directed, operate vibratory rollers in static mode when: not compacting, changing directions, or the plan depth of the pavement mat is less than 1-1/2 in.

When rolling with the 3-wheel, tandem, or vibratory rollers, start by first rolling the joint with the adjacent pavement and then continue by rolling longitudinally at the sides. Proceed toward the center of the pavement, overlapping on successive trips by at least 1 ft., unless otherwise directed. Make alternate trips of the roller slightly different in length. On superelevated curves, begin rolling at the low side and progress toward the high side, unless otherwise directed.

Avoid displacement of the mixture. If any displacement occurs, correct to the satisfaction of the Engineer. Ensure pavement is fully compacted before allowing rollers to stand on the pavement. Unless otherwise directed, use only water or an approved release agent on rollers, tamps,

330.5 to 330.6

and other compaction equipment. Keep diesel, gasoline, oil, grease, and other foreign matter off the mixture.

Use tamps to thoroughly compact the edges of the pavement along curbs, headers, and similar structures and in locations that will not allow thorough compaction with the rollers. The Engineer may require rolling with a trench roller on widened areas, in trenches, and in other limited areas.

- I. Irregularities.** Immediately take corrective actions if surface irregularities, including but not limited to segregation, rutting, raveling, flushing, fat spots, mat slippage, color, texture, roller marks, tears, gouges, streaks, or uncoated aggregate particles, are detected. The Engineer may allow placement to continue for at most 1 day of production while the Contractor takes appropriate action. If the problem still exists after that day, suspend paving until the problem is corrected to the satisfaction of the Engineer.

At the expense of the Contractor and to the satisfaction of the Engineer, remove and replace any mixture that does not bond to the existing pavement or that has other surface irregularities identified above.

- J. Ride Quality.** Use Surface Test Type A to evaluate ride quality in accordance with Item 585, "Ride Quality for Pavement Surfaces," unless otherwise shown on the plans.

330.5. Measurement. LRA pavement will be measured by the ton of composite LRA pavement of the type actually used in the completed and accepted work in accordance with the plans and specifications for the project. Measure on scales in accordance with Item 520, "Weighing and Measuring Equipment." Keep records on tare weight, gross weight, and net weight of the LRA paving mixture for each load of the same type of mixture. All water and light hydrocarbon volatiles in the mixture, in excess of 5.5% by weight at the time of weighing, will be deducted from the net weight to determine the quantity for payment.

330.6. Payment. The work performed and materials furnished in accordance with this Item and measured as provided under "Measurement" will be paid for at the unit price bid for "Limestone Rock Asphalt Pavement" of the type, grade and surface aggregate classification specified.

These prices are full compensation for surface preparation, materials including tack coat, placement, equipment, labor, tools, and incidentals.

Pay adjustment for ride quality, when required, will be determined in accordance with Item 585, "Ride Quality for Pavement Surfaces."

ITEM 334

HOT-MIX COLD-LAID ASPHALT CONCRETE PAVEMENT

334.1. Description. Construct a cold-laid pavement layer composed of a compacted mixture of aggregate and asphalt material mixed hot in a mixing plant.

This Item governs mixtures designed for cold placement, defined as placement temperatures below 175°F. If the mixture placement temperature is greater than 175°F, then design, produce, place, and compact the mixture in accordance with the applicable hot-mix asphalt specification.

334.2. Materials. Furnish uncontaminated materials of uniform quality that meet the requirements of the plans and specifications.

Notify the Engineer of all material sources. Notify the Engineer before changing any material source or formulation. When the Contractor makes a source or formulation change, the Engineer will verify that the specification requirements are met and may require a new laboratory mixture design, trial batch, or both. The Engineer may sample and test project materials at any time during the project to assure specification compliance.

A. Aggregate. Furnish aggregates from sources that conform to the requirements shown in Table 1 and on the plans. Unless otherwise directed, the Engineer will obtain the aggregate samples from materials produced for the project and perform the tests in Table 1. Mechanically crushed gravel or stone aggregates must meet the definitions in Tex-100-E. The Engineer will designate the plant or the quarry as the sampling location, and will determine aggregate gradations for mixture design and production testing based on the washed sieve analysis given in Tex-200-F, Part II. Do not add material to an approved stockpile from sources that do not meet the aggregate quality requirements of the Department's *Bituminous Rated Source Quality Catalog* (BRSQC) unless otherwise approved.

- 1. Coarse Aggregate.** Coarse aggregate stockpiles must have no more than 20% material passing the No. 8 sieve. Provide aggregates from sources listed in the BRSQC. Provide nonlisted sources only when tested by the Engineer and approved before use. Allow 30 calendar days for the Engineer to sample, test, and report results for nonlisted sources.

Provide coarse aggregate with at least the minimum surface aggregate classification (SAC) shown on the plans. SAC requirements apply only to aggregates used on the surface of travel

lanes, unless otherwise shown on the plans. The SAC for sources on the Department's Aggregate Quality Monitoring Program (AQMP) is listed in the BRSQC.

Class B aggregate meeting all other requirements in Table 1 may be blended with a Class A aggregate in order to meet requirements for Class A materials. When blending Class A and B aggregates to meet a Class A requirement, ensure that at least 50% by weight of the material retained on the No. 4 sieve comes from the Class A aggregate source. Blend by volume if the bulk specific gravities of the Class A and B aggregates differ by more than 0.300. When blending, do not use Class C or D aggregates.

2. **Fine Aggregate.** Fine aggregates consist of manufactured sands, screenings, and field sands. Fine aggregate stockpiles must meet the gradation requirements in Table 2. Supply fine aggregates that are free from organic impurities. The Engineer may test the fine aggregate in accordance with Tex-408-A to verify that the material is free from organic impurities. No more than 15% of the total aggregate may be field sand or other uncrushed fine aggregate. With the exception of field sand, use fine aggregate from coarse aggregate sources that meet the requirements shown in Table 1, unless otherwise approved.

If 10% or more of the stockpile is retained on the No. 4 sieve, test the stockpile and verify that it meets the requirements in Table 1 for coarse aggregate angularity (Tex-460-A) and flat and elongated particles (Tex-280-F).

Table 1
Aggregate Quality Requirements

Property	Test Method	Requirement
Coarse Aggregate		
SAC	AQMP	As shown on the plans
Deleterious material, %, max	Tex-217-F, Part I	1.5
Decantation, %, max	Tex-217-F, Part II	1.5
Micro-Deval abrasion, %, max	Tex-461-A	Note 1
Los Angeles abrasion, %, max	Tex-410-A	40
Magnesium sulfate soundness, 5 cycles, %, max	Tex-411-A	30 ²
Coarse aggregate angularity, 2 crushed faces, %, min	Tex-460-A, Part I	85 ³
Flat and elongated particles @ 5:1, %, max	Tex-280-F	10
Fine Aggregate		
Linear shrinkage, %, max	Tex-107-E	3
Combined Aggregates⁴		
Sand equivalent, %, min	Tex-203-F	45

1. Not used for acceptance purposes. Used by the Engineer as an indicator of the need for further investigation.

2. Unless otherwise shown on the plans.

3. Unless otherwise shown on the plans. Only applies to crushed gravel.

4. Aggregates, without added mineral filler or additives, combined as used in the job-mix formula (JMF).

Table 2
Gradation Requirements for Fine Aggregates

Sieve Size	% Passing by Weight or Volume
3/8"	100
#8	70–100
#200	0–15

B. Mineral Filler. Mineral filler consists of finely divided mineral matter such as agricultural lime, crusher fines, hydrated lime, cement, or fly ash. Mineral filler is allowed unless otherwise shown on the plans. Do not use more than 2% hydrated lime or cement, unless otherwise shown on the plans. The plans may require or disallow specific mineral fillers. When used, provide mineral filler that:

- is sufficiently dry, free-flowing, and free from clumps and foreign matter;
- does not exceed 3% linear shrinkage when tested in accordance with Tex-107-E; and
- meets the gradation requirements in Table 3.

Table 3
Gradation Requirements for Mineral Fillers

Sieve	% Passing by Weight or Volume
#8	100
#200	55–100

- C. Baghouse Fines.** Fines collected by the baghouse or other dust-collecting equipment may be reintroduced into the mixing drum.
- D. Binder Material.** Furnish asphalt, primer, additives, and water, unless otherwise shown on the plans.
 - 1. Asphalt.** Provide the asphalt shown on the plans, meeting the requirements of Item 300, “Asphalts, Oils, and Emulsions.”
 - 2. Primer.** Provide an approved asphalt primer consisting of a blend of asphalt cement and hydrocarbon volatiles.
 - 3. Water.** Provide water that meets the requirements of Item 204, “Sprinkling.”
 - 4. Additives.** When shown on the plans, use the type and rate of additive specified. Other additives that facilitate mixing or improve the quality of the mixture may be allowed when approved.

If lime or a liquid antistripping agent is used, add in accordance with Item 301, “Asphalt Antistripping Agents.” Do not add lime directly into the mixing drum of any plant where lime is removed through the exhaust stream unless the plant has a baghouse or dust collection system that reintroduces the lime back into the drum.
- E. Tack Coat.** Unless otherwise shown on the plans or approved, furnish CSS-1H, SS-1H, or a performance-graded (PG) binder with a minimum high-temperature grade of PG 58 for tack coat in accordance with Item 300, “Asphalts, Oils, and Emulsions.” Do not dilute emulsified asphalts at the terminal, in the field, or at any other location before use. The Department may sample the tack coat to verify specification compliance.

334.3. Equipment. Provide required or necessary equipment in accordance with Item 320, “Equipment for Asphalt Concrete Pavement.”

334.4. Construction. Design, produce, store, transport, place, and compact the specified paving mixture in accordance with the requirements of this Item. Unless otherwise shown on the plans, provide the mix design. The Department will perform quality assurance (QA) testing. Provide quality control (QC) testing as needed to meet the requirements of this Item.

A. Mixture Design.

- 1. Design Requirements.** Unless otherwise shown on the plans, use the typical weight design example given in Tex-204-F, Part I, to design a paving mixture that consists of a uniform mixture of aggregate, asphalt material, primer, additives, and water if allowed, which meets the requirements shown in Tables 4 and 5. Ensure that the mixture leaves the plant in a workable condition. Provide materials that remain workable in a stockpile for at least 6 mo.

At any time during the project, the Contractor may submit a new mixture design. The Engineer must approve all mixture designs before the Contractor can begin production.

- 2. Job-Mix Formula Approval.** The job-mix formula (JMF) is the combined aggregate gradation and target asphalt percentage used to establish target values for mixture production. JMF1 is the original laboratory mixture design used to produce the trial batch. The Engineer will verify JMF1 based on plant-produced mixture from the trial batch unless otherwise approved. The Engineer may accept an existing mixture design previously used on a Department project and may waive the trial batch to verify JMF1. Provide the Engineer with split samples of the mixtures and blank samples used to determine the ignition oven correction factors. The Engineer will determine the aggregate and asphalt correction factors from the ignition oven using Tex-236-F.

Table 4
Master Gradation Bands (% Passing by Weight or Volume)
and Volumetric Properties

Sieve Size	A Coarse Base	B Fine Base	C Coarse Surface	D Fine Surface	F Fine Mixture
1-1/2"	98.0–100.0	–	–	–	–
1"	78.0–94.0	98.0–100.0	–	–	–
3/4"	64.0–85.0	84.0–98.0	95.0–100.0	–	–
1/2"	50.0–70.0	–	–	98.0–100.0	–
3/8"	–	60.0–80.0	70.0–85.0	85.0–100.0	98.0–100.0
#4	30.0–50.0	40.0–60.0	43.0–63.0	50.0–70.0	80.0–86.0
#8	22.0–36.0	29.0–43.0	32.0–44.0	35.0–46.0	38.0–48.0
#30	8.0–23.0	13.0–28.0	14.0–28.0	15.0–29.0	12.0–27.0
#50	3.0–19.0	6.0–20.0	7.0–21.0	7.0–20.0	6.0–19.0
#200	2.0–7.0	2.0–7.0	2.0–7.0	2.0–7.0	2.0–7.0
Design VMA¹, % Minimum					
–	12.0	13.0	14.0	15.0	16.0
Plant-Produced VMA¹, % Minimum					
–	11.0	12.0	13.0	14.0	15.0

1. Voids in mineral aggregates.

Table 5
Laboratory Mixture Design Properties

Property	Test Method	Requirement
Target laboratory-molded density, % ¹	Tex-207-F	92.5 ± 1.5
Hveem stability, min	Tex-208-F	35
Hydrocarbon-volatile content, %, max	Tex-213-F	0.6
Moisture content, %, max ²	Tex-212-F	1.0
Boil test, %, max ³	Tex-530-C	10

1. Unless otherwise shown on the plans.

2. Unless otherwise approved.

3. Limit may be increased or eliminated when approved by the Engineer.

B. Production Operations. Perform a new trial batch when the plant or plant location is changed. Take corrective action and obtain approval to proceed after any production suspension for noncompliance to the specification.

- 1. Stockpiling of Aggregates.** Provide a smooth and well-drained area, cleared of trash, weeds, and grass. Build stockpiles in a manner that will minimize aggregate degradation and segregation. Avoid contamination and mixing of stockpiles. Provide aggregate stockpiles for a minimum of 2 days' production before beginning

plant operations. Maintain at least a 2-day aggregate supply through the course of the project unless otherwise directed. Stockpile aggregate for each source and type separately. The Engineer may reject stockpiled materials that come in contact with the earth or other objectionable material.

2. **Storage and Heating of Asphalt Materials.** Provide enough asphalt material storage capacity to meet the requirements of the plant. Do not heat the asphalt binder above the temperatures specified in Item 300, "Asphalts, Oils, and Emulsions," or from the manufacturer's recommended values. Keep all equipment used in the storage and handling of asphalt material clean at all times and operate the equipment in a manner that will prevent contamination with foreign matter.
 3. **Storage of the Asphalt Mixture.** Store the asphalt mixture in a surge-storage system or in a stockpile. If the asphalt mixture is stored in a stockpile, provide a smooth and well-drained area, cleared of trash, weeds, and grass. Build stockpiles in a manner that will minimize aggregate degradation and segregation. Avoid contamination and mixing of stockpiles.
 4. **Mixing and Discharge of Materials.** Produce the mixture at a discharge temperature between 145°F and 275°F, as directed. Do not allow the temperature to vary from the selected temperature by more than 25°F. The Department will not pay for or allow placement of any mixture produced at more than 300°F.
 5. **Moisture Content.** Furnish the mixture at a moisture content of at most 1% by weight when discharged from the mixer, unless otherwise shown on the plans or approved. Cease operations at moisture contents above 1% until corrective actions reduce moisture content.
- C. **Hauling Operations.** Before use, clean all truck beds to ensure mixture is not contaminated. When a release agent is necessary to coat truck beds, use a release agent on the approved list maintained by the Construction Division.
- D. **Placement Operations.** Prepare the surface by removing raised pavement markers and objectionable material such as moisture, dirt, sand, leaves, and other loose impediments from the surface before placing mixture. Remove vegetation from pavement edges. Place mixture on the road below 175°F. Place the mixture to produce a smooth, finished surface with a uniform appearance and texture that meet typical section requirements. Offset longitudinal joints of

334.4 to 334.4

successive courses of mixture by at least 6 in. Place mixture so longitudinal joints on the surface course coincide with lane lines, or as directed. Ensure that all finished surfaces will drain properly.

Unless otherwise shown on the plans, the asphalt mixture may be dumped in a windrow and then placed in the finishing machine with windrow pickup equipment. Prevent the windrow pickup equipment from contaminating the mixture.

After placing the paving mixture, defer compaction, as directed by the Engineer, to allow for volatilization. When placing more than 1 pavement course, allow the previous course to dry and cure before placing the next course. Unless otherwise directed, the course will be considered cured if the hydrocarbon volatile content of the mixture is 0.4% or less by weight of the mixture when tested according to Tex-213-F.

When shown on the plans or as approved, a motor grader may be used to spread the mixture. Thoroughly aerate the mixture and spread into place with a power motor grader in a uniform layer. Placement in narrow strips or small irregular areas may require hand spreading.

1. **Weather Conditions.** Place the mixture when the roadway surface temperature is 60°F or higher unless otherwise approved. Unless otherwise shown on the plans, place mixtures only when weather conditions and moisture conditions of the roadway surface are suitable in the opinion of the Engineer.
 2. **Tack Coat.** Clean the surface before placing the tack coat. Unless otherwise approved, apply tack coat uniformly at the rate directed by the Engineer. The Engineer will set the rate between 0.04 and 0.10 gal. of residual asphalt per square yard of surface area. Apply a thin, uniform tack coat to all contact surfaces of curbs, structures, and joints. Prevent splattering of the tack coat when placed adjacent to curb, gutter, and structures. Roll the tack coat with a pneumatic-tire roller when directed. The Engineer may use Tex-243-F to verify that the tack coat has adequate adhesive properties. The Engineer may suspend paving operations until there is adequate adhesion.
- E. Compaction.** Furnish the type, size, and number of rollers required for compaction, as approved. Furnish at least 1 medium pneumatic-tire roller (minimum 12-ton weight). Use the control strip method given in Tex-207-F, Part IV, to establish rolling patterns that achieve maximum compaction. Follow the selected rolling pattern unless changes that affect compaction occur in the mixture or placement conditions. When

such changes occur, establish a new rolling pattern. Compact the pavement to the cross section of the finished paving mixture meeting the requirements of the plans and specifications. Unless otherwise directed, operate vibratory rollers in static mode when not compacting, when changing directions, or when the plan depth of the pavement mat is less than 1-1/2 in.

When rolling with the 3-wheel tandem or vibratory rollers, start by first rolling the joint with the adjacent pavement and then continue by rolling longitudinally at the sides. Proceed toward the center of the pavement, overlapping on successive trips by at least 1 ft., unless otherwise directed. Make alternate trips of the roller slightly different in length. On superelevated curves, begin rolling at the low side and progress toward the high side unless otherwise directed.

Avoid displacement of the mixture. If any displacement occurs, correct to the satisfaction of the Engineer. Ensure pavement is fully compacted before allowing rollers to stand on the pavement. Unless otherwise directed, use only water or an approved release agent on rollers, tamps, and other compaction equipment. Keep diesel, gasoline, oil, grease, and other foreign matter off the mixture.

Use tamps to thoroughly compact the edges of the pavement along curbs, headers, and similar structures and in locations that will not allow thorough compaction with the rollers. The Engineer may require rolling with a trench roller on widened areas, in trenches, and in other limited areas.

Allow the compacted pavement to cool to 160°F or lower before opening to traffic unless otherwise directed. When directed, sprinkle the finished mat with water or limewater to expedite opening the roadway to traffic.

- F. Production Testing and Operational Tolerances.** The aggregate gradation and the asphalt binder content of the produced mixture must not vary from the JMF by more than the percentage point tolerances shown in Table 6. The gradation of the produced mixture may fall outside the master grading limits for any of the sieve sizes from the 1-1/2 in. through the No. 50 sieve if it is within the JMF tolerances. The aggregate gradation of the No. 200 sieve may not exceed the master gradations shown in Table 4. Any sieve size shown in Table 4 with 100% passing requirements will be allowed a 2% tolerance before the material is considered out of specification.

If the aggregate mineralogy is such that Tex-236-F does not yield reliable results, the Engineer may allow alternate methods for

334.4 to 334.4

determining the asphalt content and aggregate gradation. Unless otherwise allowed, the Engineer will require the Contractor to provide evidence that results from Tex-236-F are not reliable before permitting an alternate method. If an alternate test method is allowed, use the applicable test procedure as directed.

If during production, 3 consecutive tests indicate that the material produced exceeds the tolerances shown in Table 6 for any individual sieve or for laboratory-molded density, cease production until corrective actions are taken and the results approved. If 2 consecutive tests indicate that the asphalt binder content tolerances shown in Table 6 are exceeded, cease production until corrective actions are taken and the results approved.

If the Hveem stability shown in Table 5 is not met for 3 consecutive tests, cease production until corrective actions are taken and the results approved.

Table 6
Operational Tolerances

Property	Test Method	Operational Tolerance From JMF
Individual % retained for sieve sizes smaller than 1-1/2" and larger than #8	Tex-200-F	±5.0
Individual % retained for sieve sizes smaller than #8		±3.0
Asphalt binder content, %	Tex-236-F	±0.3
Laboratory-molded density, %	Tex-207-F	±1.0

G. Irregularities. Immediately take corrective action if surface irregularities, including but not limited to segregation, rutting, raveling, flushing, fat spots, mat slippage, color, texture, roller marks, tears, gouges, streaks, or uncoated aggregate particles, are detected. The Engineer may suspend production or placement operations until the problem is corrected.

At the expense of the Contractor and to the satisfaction of the Engineer, remove and replace any mixture that does not bond to the existing pavement or that has other surface irregularities identified above.

H. Ride Quality. Use Surface Test Type A to evaluate ride quality in accordance with Item 585, "Ride Quality for Pavement Surfaces," unless otherwise shown on the plans.

334.5. Measurement. This Item will be measured by the by the ton of composite asphalt concrete mixture of the type used in the completed and accepted work.

Measurement will be made on scales in accordance with Item 520, “Weighing and Measuring Equipment.”

For mixture produced by a weigh-batch plant or a modified weigh-batch plant, measurement will be determined on the batch scales unless surge-storage or stockpiling is used. Keep records of the number of batches, batch design, and the weight of the composite asphalt concrete mixture. The composite asphalt concrete mixture is defined as the asphalt, primer, aggregate, additives, and any residual moisture that is not designated to be deducted. Where surge-storage or stockpiling is used, measurement of the material taken from the surge-storage bin or stockpile will be made on truck scales or suspended hopper scales.

334.6. Payment. The work performed and materials furnished in accordance with this Item and measured as provided under Article 334.5, “Measurement,” will be paid for at the unit price bid for “Hot-Mix Cold-Laid Asphalt Concrete Pavement” of the type, surface aggregate classification, and asphalt binder specified.

This price is full compensation for surface preparation, materials including tack coat, placement, equipment, labor, tools, and incidentals.

Pay adjustment for ride quality, when required, will be determined in accordance with Item 585, “Ride Quality for Pavement Surfaces.”

ITEM 340

DENSE-GRADED HOT-MIX ASPHALT (METHOD)

340.1. Description. Construct a pavement layer composed of a compacted, dense-graded mixture of aggregate and asphalt binder mixed hot in a mixing plant.

340.2. Materials. Furnish uncontaminated materials of uniform quality that meet the requirements of the plans and specifications.

Notify the Engineer of all material sources. Notify the Engineer before changing any material source or formulation. When the Contractor makes a source or formulation change, the Engineer will verify that the requirements of this Item are met and may require a new laboratory mixture design, trial

340.2 to 340.2

batch, or both. The Engineer may sample and test project materials at any time during the project to verify compliance.

A. Aggregate. Furnish aggregates from sources that conform to the requirements shown in Table 1, and as specified in this Section, unless otherwise shown on the plans. Provide aggregate stockpiles that meet the definition in this Section for either coarse aggregate or fine aggregate. When reclaimed asphalt pavement (RAP) is allowed by plan note, provide RAP stockpiles in accordance with this Section. Aggregate from RAP is not required to meet Table 1 requirements unless otherwise shown on the plans. Supply mechanically crushed gravel or stone aggregates that meet the definitions in Tex-100-E. The Engineer will designate the plant or the quarry as the sampling location. Samples must be from materials produced for the project. The Engineer will establish the surface aggregate classification (SAC) and perform Los Angeles abrasion, magnesium sulfate soundness, and Micro-Deval tests. Perform all other aggregate quality tests listed in Table 1. Document all test results on the mixture design report. The Engineer may perform tests on independent or split samples to verify Contractor test results. Stockpile aggregates for each source and type separately. Determine aggregate gradations for mixture design and production testing based on the washed sieve analysis given in Tex-200-F, Part II. Do not add material to an approved stockpile from sources that do not meet the aggregate quality requirements of the Department's *Bituminous Rated Source Quality Catalog* (BRSQC) unless otherwise approved.

1. Coarse Aggregate. Coarse aggregate stockpiles must have no more than 20% material passing the No. 8 sieve. Provide aggregates from sources listed in the BRSQC. Provide aggregate from nonlisted sources only when tested by the Engineer and approved before use. Allow 30 calendar days for the Engineer to sample, test, and report results for nonlisted sources.

Provide coarse aggregate with at least the minimum SAC shown on the plans. SAC requirements apply only to aggregates used on the surface of travel lanes, unless otherwise shown on the plans. The SAC for sources on the Department's AQMP is listed in the BRSQC.

Class B aggregate meeting all other requirements in Table 1 may be blended with a Class A aggregate in order to meet requirements for Class A materials. When blending Class A and B aggregates to meet a Class A requirement, ensure that at least 50% by weight of

the material retained on the No. 4 sieve comes from the Class A aggregate source. Blend by volume if the bulk specific gravities of the Class A and B aggregates differ by more than 0.300. When blending, do not use Class C or D aggregates. For blending purposes, coarse aggregate from RAP will be considered as Class B aggregate.

2. **RAP.** RAP is salvaged, milled, pulverized, broken, or crushed asphalt pavement. Crush or break RAP so that 100% of the particles pass the 2-in. sieve.

RAP from either Contractor- or Department-owned sources, including RAP generated during the project, is permitted only when shown on the plans. Department-owned RAP, if allowed for use, will be available at the location shown on the plans. When RAP is used, determine asphalt content and gradation for mixture design purposes. Perform other tests on RAP when shown on the plans.

When RAP is allowed by plan note, use no more than 30% RAP in Type A or B mixtures unless otherwise shown on the plans. For all other mixtures, use no more than 20% RAP unless otherwise shown on the plans.

Do not use RAP contaminated with dirt or other objectionable materials. Do not use the RAP if the decantation value exceeds 5% and the plasticity index is greater than 8. Test the stockpiled RAP for decantation in accordance with the laboratory method given in Tex-406-A, Part I. Determine the plasticity index using Tex-106-E if the decantation value exceeds 5%. The decantation and plasticity index requirements do not apply to RAP samples with asphalt removed by extraction.

Do not intermingle Contractor-owned RAP stockpiles with Department-owned RAP stockpiles. Remove unused Contractor-owned RAP material from the project site upon completion of the project. Return unused Department-owned RAP to the designated stockpile location.

3. **Fine Aggregate.** Fine aggregates consist of manufactured sands, screenings, and field sands. Fine aggregate stockpiles must meet the gradation requirements in Table 2. Supply fine aggregates that are free from organic impurities. The Engineer may test the fine aggregate in accordance with Tex-408-A to verify the material is free from organic impurities. At most 15% of the total aggregate may be field sand or other uncrushed fine aggregate. With the

340.2 to 340.2

exception of field sand, use fine aggregate from coarse aggregate sources that meet the requirements shown in Table 1, unless otherwise approved.

If 10% or more of the stockpile is retained on the No. 4 sieve, test the stockpile and verify that it meets the requirements in Table 1 for coarse aggregate angularity (Tex-460-A) and flat and elongated particles (Tex-280-F).

**Table 1
Aggregate Quality Requirements**

Property	Test Method	Requirement
Coarse Aggregate		
SAC	AQMP	As shown on plans
Deleterious material, %, max	Tex-217-F, Part I	1.5
Decantation, %, max	Tex-217-F, Part II	1.5
Micro-Deval abrasion, %, max	Tex-461-A	Note 1
Los Angeles abrasion, %, max	Tex-410-A	40
Magnesium sulfate soundness, 5 cycles, %, max	Tex-411-A	30 ²
Coarse aggregate angularity, 2 crushed faces, %, min	Tex 460-A, Part I	85 ³
Flat and elongated particles @ 5:1, %, max	Tex-280-F	10
Fine Aggregate		
Linear shrinkage, %, max	Tex-107-E	3
Combined Aggregate⁴		
Sand equivalent, %, min	Tex-203-F	45

1. Not used for acceptance purposes. Used by the Engineer as an indicator of the need for further investigation.

2. Unless otherwise shown on the plans.

3. Unless otherwise shown on the plans. Only applies to crushed gravel.

4. Aggregates, without mineral filler, RAP, or additives, combined as used in the job-mix formula (JMF).

**Table 2
Gradation Requirements for Fine Aggregate**

Sieve Size	% Passing by Weight or Volume
3/8"	100
#8	70–100
#200	0–30

B. Mineral Filler. Mineral filler consists of finely divided mineral matter such as agricultural lime, crusher fines, hydrated lime, cement, or fly ash. Mineral filler is allowed unless otherwise shown on the plans. Do not use more than 2% hydrated lime or cement, unless otherwise shown on the plans. The plans may require or disallow specific mineral fillers. When used, provide mineral filler that:

- is sufficiently dry, free-flowing, and free from clumps and foreign matter;
- does not exceed 3% linear shrinkage when tested in accordance with Tex-107-E; and
- meets the gradation requirements in Table 3.

Table 3
Gradation Requirements for Mineral Filler

Sieve Size	% Passing by Weight or Volume
#8	100
#200	55-100

- C. Baghouse Fines.** Fines collected by the baghouse or other dust-collecting equipment may be reintroduced into the mixing drum.
- D. Asphalt Binder.** Furnish the type and grade of performance-graded (PG) asphalt binder specified on the plans in accordance with Section 300.2.J, “Performance-Graded Binders.”
- E. Tack Coat.** Unless otherwise shown on the plans or approved, furnish CSS-1H, SS-1H, or a PG binder with a minimum high-temperature grade of PG 58 for tack coat binder in accordance with Item 300, “Asphalts, Oils, and Emulsions.”

Do not dilute emulsified asphalts at the terminal, in the field, or at any other location before use. If required, verify that emulsified asphalt proposed for use meets the minimum residual asphalt percentage specified in Item 300, “Asphalts, Oils, and Emulsions.”

The Engineer will obtain at least 1 sample of the tack coat binder per project and test it to verify compliance with Item 300. The Engineer will obtain the sample from the asphalt distributor immediately before use.

- F. Additives.** When shown on the plans, use the type and rate of additive specified. Other additives that facilitate mixing or improve the quality of the mixture may be allowed when approved.

If lime or a liquid antistripping agent is used, add in accordance with Item 301, “Asphalt Antistripping Agents.” Do not add lime directly into the mixing drum of any plant where lime is removed through the exhaust stream unless the plant has a baghouse or dust collection system that reintroduces the lime back into the drum.

340.3. Equipment. Provide required or necessary equipment in accordance with Item 320, “Equipment for Asphalt Concrete Pavement.”

340.4 to 340.4

340.4. Construction. Design, produce, store, transport, place, and compact the specified paving mixture in accordance with the requirements of this Item. Unless otherwise shown on the plans, provide the mix design. The Department will perform quality assurance (QA) testing. Provide quality control (QC) testing as needed to meet the requirements of this Item.

A. Mixture Design.

- 1. Design Requirements.** Use a Level II specialist certified by a Department-approved hot-mix asphalt certification program to develop the mixture design. Have the Level II specialist sign the design documents. Unless otherwise shown on the plans, use the typical weight design example given in Tex-204-F, Part I, to design a mixture meeting the requirements listed in Tables 1 through 6. Use an approved laboratory to perform the Hamburg Wheel test and provide results with the mixture design, or provide the laboratory mixture and request that the Department perform the Hamburg Wheel test. The Construction Division maintains a list of approved laboratories. Furnish the Engineer with representative samples of all materials used in the mixture design. The Engineer will verify the mixture design. If the design cannot be verified by the Engineer, furnish another mixture design.

The Contractor may submit a new mixture design at anytime during the project. The Engineer will approve all mixture designs before the Contractor can begin production.

Provide the Engineer with a mixture design report using Department-provided software. Include the following items in the report:

- the combined aggregate gradation, source, specific gravity, and percent of each material used;
- results of all applicable tests;
- the mixing and molding temperatures;
- the signature of the Level II person or persons who performed the design;
- the date the mixture design was performed; and
- a unique identification number for the mixture design.

Table 4
Master Gradation Bands (% Passing by Weight or Volume)
and Volumetric Properties

Sieve Size	A Coarse Base	B Fine Base	C Coarse Surface	D Fine Surface	F Fine Mixture
1-1/2"	98.0–100.0	–	–	–	–
1"	78.0–94.0	98.0–100.0	–	–	–
3/4"	64.0–85.0	84.0–98.0	95.0–100.0	–	–
1/2"	50.0–70.0	–	–	98.0–100.0	–
3/8"	–	60.0–80.0	70.0–85.0	85.0–100.0	98.0–100.0
#4	30.0–50.0	40.0–60.0	43.0–63.0	50.0–70.0	80.0–86.0
#8	22.0–36.0	29.0–43.0	32.0–44.0	35.0–46.0	38.0–48.0
#30	8.0–23.0	13.0–28.0	14.0–28.0	15.0–29.0	12.0–27.0
#50	3.0–19.0	6.0–20.0	7.0–21.0	7.0–20.0	6.0–19.0
#200	2.0–7.0	2.0–7.0	2.0–7.0	2.0–7.0	2.0–7.0
Design VMA¹, % Minimum					
–	12.0	13.0	14.0	15.0	16.0
Plant-Produced VMA, % Minimum					
–	11.0	12.0	13.0	14.0	15.0

1. Voids in Mineral Aggregates.

Table 5
Laboratory Mixture Design Properties

Property	Test Method	Requirement
Target laboratory-molded density, %	Tex-207-F	96.0 ¹
Tensile strength (dry), psi (molded to 93% ±1% density)	Tex-226-F	85–200 ²
Boil test ³	Tex-530-C	–

1. Unless otherwise shown on the plans.

2. May exceed 200 psi when approved and may be waived when approved.

3. Used to establish baseline for comparison to production results. May be waived when approved.

Table 6
Hamburg Wheel Test Requirements¹

High-Temperature Binder Grade	Minimum # of Passes ² @ 0.5" Rut Depth, Tested @ 122°F
PG 64 or lower	10,000
PG 70	15,000
PG 76 or higher	20,000

1. Tested in accordance with Tex-242-F.

2. May be decreased or waived when shown on the plans.

B. Job-Mix Formula Approval. The job-mix formula (JMF) is the combined aggregate gradation and target asphalt percentage used to establish target values for mixture production. JMF is the original

340.4 to 340.4

laboratory mixture design used to produce the trial batch. The Engineer and the Contractor will verify JMF based on plant-produced mixture from the trial batch unless otherwise approved. The Engineer may accept an existing mixture design previously used on a Department project and may waive the trial batch to verify JMF. If the JMF is not verified by the Engineer from the trial batch, adjust the JMF or redesign the mix and produce as many trial batches as necessary to verify the JMF.

Provide the Engineer with split samples of the mixtures and blank samples used to determine the ignition oven correction factors. The Engineer will determine the aggregate and asphalt correction factors from the ignition oven using Tex-236-F.

The Engineer will use a Texas gyratory compactor calibrated in accordance with Tex-914-F in molding production samples.

The Engineer will perform Tex-530-C and retain the tested sample for comparison purposes during production. The Engineer may waive the requirement for the boil test.

C. JMF Field Adjustments. Produce a mixture of uniform composition closely conforming to the approved JMF.

If, during initial days of production, the Contractor or Engineer determines that adjustments to the JMF are necessary to achieve the specified requirements, or to more nearly match the aggregate production, the Engineer may allow adjustment of the JMF within the tolerances of Table 7 without a laboratory redesign of the mixture.

The Engineer will adjust the asphalt content to maintain desirable laboratory density near the optimum value while achieving other mix requirements.

Table 7
Operational Tolerances

Description	Test Method	Allowable Difference from JMF Target
Individual % retained for #8 sieve and larger	Tex-200-F or Tex-236-F	±5.0 ¹
Individual % retained for sieves smaller than #8 and larger than #200		±3.0 ¹
% passing the #200 sieve		±2.0 ¹
Asphalt content, %	Tex-236-F	±0.3 ¹
Laboratory-molded density, %	Tex-207-F	±1.0
VMA, %, min		Note 2

1. When within these tolerances, mixture production gradations may fall outside the master grading limits; however, the percent passing the #200 sieve will be considered out of tolerance when outside the master grading limits.

2. Test and verify that Table 4 requirements are met.

D. Production Operations. Perform a new trial batch when the plant or plant location is changed. The Engineer may suspend production for noncompliance with this Item. Take corrective action and obtain approval to proceed after any production suspension for noncompliance.

1. Operational Tolerances. During production, do not exceed the operational tolerances in Table 7. Stop production if testing indicates tolerances are exceeded on:

- 3 consecutive tests on any individual sieve,
- 4 consecutive tests on any of the sieves, or
- 2 consecutive tests on asphalt content.

Begin production only when test results or other information indicate, to the satisfaction of the Engineer, that the next mixture produced will be within Table 7 tolerances.

2. Storage and Heating of Materials. Do not heat the asphalt binder above the temperatures specified in Item 300, “Asphalts, Oils, and Emulsions” or outside the manufacturer’s recommended values. On a daily basis, provide the Engineer with the records of asphalt binder and hot-mix asphalt discharge temperatures in accordance with Item 320, “Equipment for Asphalt Concrete Pavement.” Unless otherwise approved, do not store mixture for a period long enough to affect the quality of the mixture, nor in any case longer than 12 hr.

3. Mixing and Discharge of Materials. Notify the Engineer of the target discharge temperature and produce the mixture within 25°F of the target. Monitor the temperature of the material in the truck

340.4 to 340.4

before shipping to ensure that it does not exceed 350°F. The Department will not pay for or allow placement of any mixture produced at more than 350°F. Control the mixing time and temperature so that substantially all moisture is removed from the mixture before discharging from the plant.

- E. Hauling Operations.** Before use, clean all truck beds to ensure mixture is not contaminated. When a release agent is necessary to coat truck beds, use a release agent on the approved list maintained by the Construction Division.
- F. Placement Operations.** Prepare the surface by removing raised pavement markers and objectionable material such as moisture, dirt, sand, leaves, and other loose impediments from the surface before placing mixture. Remove vegetation from pavement edges. Place the mixture to meet the typical section requirements and produce a smooth, finished surface with a uniform appearance and texture. Offset longitudinal joints of successive courses of hot mix by at least 6 in. Place mixture so longitudinal joints on the surface course coincide with lane lines, or as directed. Ensure that all finished surfaces will drain properly. Place mixture within the compacted lift thickness shown in Table 8, unless otherwise shown on the plans or allowed.

Table 8
Compacted Lift Thickness and Required Core Height

Mixture Type	Compacted Lift Thickness	
	Minimum (in.)	Maximum (in.)
A	3.00	6.00
B	2.50	5.00
C	2.00	4.00
D	1.50	3.00
F	1.25	2.50

- 1. Weather Conditions.** Place mixture when the roadway surface temperature is 60°F or higher unless otherwise approved. Measure the roadway surface temperature with a handheld infrared thermometer. Unless otherwise shown on the plans, place mixtures only when weather conditions and moisture conditions of the roadway surface are suitable in the opinion of the Engineer.
- 2. Tack Coat.** Clean the surface before placing the tack coat. Unless otherwise approved, apply tack coat uniformly at the rate directed by the Engineer. The Engineer will set the rate between 0.04 and 0.10 gal. of residual asphalt per square yard of surface area. Apply

a thin, uniform tack coat to all contact surfaces of curbs, structures, and all joints. Prevent splattering of tack coat when placed adjacent to curb, gutter, and structures. Roll the tack coat with a pneumatic-tire roller when directed. The Engineer may use Tex-243-F to verify that the tack coat has adequate adhesive properties. The Engineer may suspend paving operations until there is adequate adhesion.

G. Lay-Down Operations.

1. **Minimum Mixture Placement Temperatures.** Use Table 9 for suggested minimum mixture placement temperatures.
2. **Windrow Operations.** When hot mix is placed in windrows, operate windrow pickup equipment so that substantially all the mixture deposited on the roadbed is picked up and loaded into the paver.

Table 9
Suggested Minimum Mixture Placement Temperature

High-Temperature Binder Grade	Minimum Placement Temperature (Before Entering Paver)
PG 64 or lower	260°F
PG 70	270°F
PG 76	280°F
PG 82 or higher	290°F

H. Compaction. Use air void control unless ordinary compaction control is specified on the plans. Avoid displacement of the mixture. If displacement occurs, correct to the satisfaction of the Engineer. Ensure pavement is fully compacted before allowing rollers to stand on the pavement. Unless otherwise directed, use only water or an approved release agent on rollers, tamps, and other compaction equipment. Keep diesel, gasoline, oil, grease, and other foreign matter off the mixture. Unless otherwise directed, operate vibratory rollers in static mode when not compacting, when changing directions, or when the plan depth of the pavement mat is less than 1-1/2 in.

Use tamps to thoroughly compact the edges of the pavement along curbs, headers, and similar structures and in locations that will not allow thorough compaction with the rollers. The Engineer may require rolling with a trench roller on widened areas, in trenches, and in other limited areas.

340.4 to 340.4

Allow the compacted pavement to cool to 160°F or lower before opening to traffic unless otherwise directed. When directed, sprinkle the finished mat with water or limewater to expedite opening the roadway to traffic.

1. **Air Void Control.** Compact dense-graded hot-mix asphalt to contain from 5% to 9% in-place air voids. Do not increase the asphalt content of the mixture to reduce pavement air voids.
 - a. **Rollers.** Furnish the type, size, and number of rollers required for compaction, as approved. Use a pneumatic-tire roller to seal the surface, unless otherwise shown on the plans. Use additional rollers as required to remove any roller marks.
 - b. **Air Void Determination.** Unless otherwise shown on the plans, obtain 2 roadway specimens at each location selected by the Engineer for in-place air void determination. The Engineer will measure air voids in accordance with Tex-207-F and Tex-227-F. Before drying to a constant weight, cores may be predried using a Corelok or similar vacuum device to remove excess moisture. The Engineer will use the average air void content of the 2 cores to calculate the in-place air voids at the selected location.
 - c. **Air Voids Out of Range.** If the in-place air void content in the compacted mixture is below 5% or greater than 9%, change the production and placement operations to bring the in-place air void content within requirements. The Engineer may suspend production until the in-place air void content is brought to the required level, and may require a test section as described in Section 340.4.H.1.d, “Test Section.”
 - d. **Test Section.** Construct a test section of 1 lane-width and at most 0.2 mi. in length to demonstrate that compaction to between 5% and 9% in-place air voids can be obtained. Continue this procedure until a test section with 5% to 9% in-place air voids can be produced. The Engineer will allow only 2 test sections per day. When a test section producing satisfactory in-place air void content is placed, resume full production.
2. **Ordinary Compaction Control.** Furnish the type, size, and number of rollers required for compaction, as approved. Furnish at least 1 medium pneumatic-tire roller (minimum 12-ton weight). Use the control strip method given in Tex-207-F, Part IV, to establish rolling patterns that achieve maximum compaction.

Follow the selected rolling pattern unless changes that affect compaction occur in the mixture or placement conditions. When such changes occur, establish a new rolling pattern. Compact the pavement to meet the requirements of the plans and specifications.

When rolling with the 3-wheel, tandem or vibratory rollers, start by first rolling the joint with the adjacent pavement and then continue by rolling longitudinally at the sides. Proceed toward the center of the pavement, overlapping on successive trips by at least 1 ft., unless otherwise directed. Make alternate trips of the roller slightly different in length. On superelevated curves, begin rolling at the low side and progress toward the high side unless otherwise directed.

- I. Irregularities.** Immediately take corrective action if surface irregularities, including but not limited to segregation, rutting, raveling, flushing, fat spots, mat slippage, color, texture, roller marks, tears, gouges, streaks, or uncoated aggregate particles, are detected. The Engineer may suspend production or placement operations until the problem is corrected.

At the expense of the Contractor and to the satisfaction of the Engineer, remove and replace any mixture that does not bond to the existing pavement or that has other surface irregularities identified above.

- J. Ride Quality.** Use Surface Test Type A to evaluate ride quality in accordance with Item 585, "Ride Quality for Pavement Surfaces," unless otherwise shown on the plans.

340.5. Measurement. Hot mix will be measured by the ton of composite hot mix, which includes asphalt, aggregate, and additives. Measure the weight on scales in accordance with Item 520, "Weighing and Measuring Equipment."

340.6. Payment. The work performed and materials furnished in accordance with this Item and measured as provided under "Measurement" will be paid for at the unit price bid for "Dense-Graded Hot-Mix Asphalt (Method)" of the type, surface aggregate classification, and binder specified. These prices are full compensation for surface preparation, materials including tack coat, placement, equipment, labor, tools, and incidentals.

Trial batches will not be paid for unless they are incorporated into pavement work approved by the Department.

341.1 to 341.2

Pay adjustment for ride quality, when required, will be determined in accordance with Item 585, "Ride Quality for Pavement Surfaces."

ITEM 341

DENSE-GRADED HOT-MIX ASPHALT (QC/QA)

341.1. Description. Construct a pavement layer composed of a compacted, dense-graded mixture of aggregate and asphalt binder mixed hot in a mixing plant.

341.2. Materials. Furnish uncontaminated materials of uniform quality that meet the requirements of the plans and specifications.

Notify the Engineer of all material sources. Notify the Engineer before changing any material source or formulation. When the Contractor makes a source or formulation change, the Engineer will verify that the specification requirements are met and may require a new laboratory mixture design, trial batch, or both. The Engineer may sample and test project materials at any time during the project to verify specification compliance.

A. Aggregate. Furnish aggregates from sources that conform to the requirements shown in Table 1, and as specified in this Section, unless otherwise shown on the plans. Provide aggregate stockpiles that meet the definition in this Section for either a coarse aggregate or fine aggregate. When reclaimed asphalt pavement (RAP) is allowed by plan note, provide RAP stockpiles in accordance with this Section. Aggregate from RAP is not required to meet Table 1 requirements unless otherwise shown on the plans. Supply mechanically crushed gravel or stone aggregates that meet the definitions in Tex-100-E. The Engineer will designate the plant or the quarry as the sampling location. Samples must be from materials produced for the project. The Engineer will establish the surface aggregate classification (SAC) and perform Los Angeles abrasion, magnesium sulfate soundness, and Micro-Deval tests. Perform all other aggregate quality tests listed in Table 1. Document all test results on the mixture design report. The Engineer may perform tests on independent or split samples to verify Contractor test results. Stockpile aggregates for each source and type separately. Determine aggregate gradations for mixture design and production testing based on the washed sieve analysis given in Tex-200-F, Part II. Do not add material to an approved stockpile from sources that do not meet the aggregate quality requirements of the Department's

Bituminous Rated Source Quality Catalog (BRSQC) unless otherwise approved.

1. **Coarse Aggregate.** Coarse aggregate stockpiles must have no more than 20% material passing the No. 8 sieve. Provide aggregates from sources listed in the BRSQC. Provide aggregate from nonlisted sources only when tested by the Engineer and approved before use. Allow 30 calendar days for the Engineer to sample, test, and report results for nonlisted sources.

Provide coarse aggregate with at least the minimum SAC as shown on the plans. SAC requirements apply only to aggregates used on the surface of travel lanes, unless otherwise shown on the plans. The SAC for sources on the Department's Aggregate Quality Monitoring Program (AQMP) is listed in the BRSQC.

Class B aggregate meeting all other requirements in Table 1 may be blended with a Class A aggregate in order to meet requirements for Class A materials. When blending Class A and B aggregates to meet a Class A requirement, ensure that at least 50% by weight of the material retained on the No. 4 sieve comes from the Class A aggregate source. Blend by volume if the bulk specific gravities of the Class A and B aggregates differ by more than 0.300. When blending, do not use Class C or D aggregates. For blending purposes, coarse aggregate from RAP will be considered as Class B aggregate.

2. **RAP.** RAP is salvaged, milled, pulverized, broken, or crushed asphalt pavement. Crush or break RAP so that 100% of the particles pass the 2-in. sieve.

RAP from either Contractor- or Department-owned sources, including RAP generated during the project, is permitted only when shown on the plans. Department-owned RAP, if allowed for use, will be available at the location shown on the plans. When RAP is used, determine asphalt content and gradation for mixture design purposes. Perform other tests on RAP when shown on the plans.

When RAP is allowed by plan note, use no more than 30% RAP in Type A or B mixtures unless otherwise shown on the plans. For all other mixtures, use no more than 20% RAP unless otherwise shown on the plans.

Do not use RAP contaminated with dirt or other objectionable materials. Do not use the RAP if the decantation value exceeds 5%

341.2 to 341.2

and the plasticity index is greater than 8. Test the stockpiled RAP for decantation in accordance with the laboratory method given in Tex-406-A, Part I. Determine the plasticity index using Tex-106-E if the decantation value exceeds 5%. The decantation and plasticity index requirements do not apply to RAP samples with asphalt removed by extraction.

Do not intermingle Contractor-owned RAP stockpiles with Department-owned RAP stockpiles. Remove unused Contractor-owned RAP material from the project site upon completion of the project. Return unused Department-owned RAP to the designated stockpile location.

- 3. Fine Aggregate.** Fine aggregates consist of manufactured sands, screenings, and field sands. Fine aggregate stockpiles must meet the gradation requirements in Table 2. Supply fine aggregates that are free from organic impurities. The Engineer may test the fine aggregate in accordance with Tex-408-A to verify the material is free from organic impurities. At most 15% of the total aggregate may be field sand or other uncrushed fine aggregate. With the exception of field sand, use fine aggregate from coarse aggregate sources that meet the requirements shown in Table 1, unless otherwise approved.

If 10% or more of the stockpile is retained on the No. 4 sieve, test the stockpile and verify that it meets the requirements in Table 1 for coarse aggregate angularity (Tex-460-A) and flat and elongated particles (Tex-280-F).

Table 1
Aggregate Quality Requirements

Property	Test Method	Requirement
Coarse Aggregate		
SAC	AQMP	As shown on plans
Deleterious material, %, max	Tex-217-F, Part I	1.5
Decantation, %, max	Tex-217-F, Part II	1.5
Micro-Deval abrasion, %, max	Tex-461-A	Note 1
Los Angeles abrasion, %, max	Tex-410-A	40
Magnesium sulfate soundness, 5 cycles, %, max	Tex-411-A	30
Coarse aggregate angularity, 2 crushed faces, %, Min	Tex 460-A, Part I	85 ²
Flat and elongated particles @ 5:1, %, max	Tex-280-F	10
Fine Aggregate		
Linear shrinkage, %, Max	Tex-107-E	3
Combined Aggregate³		
Sand equivalent, %, Min	Tex-203-F	45

1. Not used for acceptance purposes. Used by the Engineer as an indicator of the need for further investigation.
2. Only applies to crushed gravel.
3. Aggregates, without mineral filler, RAP, or additives, combined as used in the job-mix formula (JMF).

Table 2
Gradation Requirements for Fine Aggregate

Sieve Size	% Passing by Weight or Volume
3/8"	100
#8	70-100
#200	0-30

- B. Mineral Filler.** Mineral filler consists of finely divided mineral matter such as agricultural lime, crusher fines, hydrated lime, cement, or fly ash. Mineral filler is allowed unless otherwise shown on the plans. Do not use more than 2% hydrated lime or cement, unless otherwise shown on the plans. The plans may require or disallow specific mineral fillers. When used, provide mineral filler that:
- is sufficiently dry, free-flowing, and free from clumps and foreign matter;
 - does not exceed 3% linear shrinkage when tested in accordance with Tex-107-E; and
 - meets the gradation requirements in Table 3.

341.3 to 341.4

Table 3
Gradation Requirements for Mineral Filler

Sieve Size	% Passing by Weight or Volume
#8	100
#200	55-100

- C. **Baghouse Fines.** Fines collected by the baghouse or other dust-collecting equipment may be reintroduced into the mixing drum.
- D. **Asphalt Binder.** Furnish the type and grade of performance-graded (PG) asphalt binder specified on the plans in accordance with Section 300.2.J, “Performance-Graded Binders.”
- E. **Tack Coat.** Unless otherwise shown on the plans or approved, furnish CSS-1H, SS-1H, or a PG binder with a minimum high-temperature grade of PG 58 for tack coat binder in accordance with Item 300, “Asphalts, Oils, and Emulsions.” Do not dilute emulsified asphalts at the terminal, in the field, or at any other location before use.

The Engineer will obtain at least 1 sample of the tack coat binder per project and test it to verify compliance with Item 300. The Engineer will obtain the sample from the asphalt distributor immediately before use.

- F. **Additives.** When shown on the plans, use the type and rate of additive specified. Other additives that facilitate mixing or improve the quality of the mixture may be allowed when approved.

If lime or a liquid antistripping agent is used, add in accordance with Item 301, “Asphalt Antistripping Agents.” Do not add lime directly into the mixing drum of any plant where lime is removed through the exhaust stream unless the plant has a baghouse or dust collection system that reintroduces the lime back into the drum.

341.3. Equipment. Provide required or necessary equipment in accordance with Item 320, “Equipment for Asphalt Concrete Pavement.”

341.4. Construction. Produce, haul, place, and compact the specified paving mixture. Schedule and participate in a prepaving meeting with the Engineer as required in the Quality Control Plan (QCP).

- A. **Certification.** Personnel certified by the Department-approved hot-mix asphalt certification program must conduct all mixture designs, sampling, and testing in accordance with Table 4. Supply the Engineer with a list of certified personnel and copies of their current certificates before beginning production and when personnel changes are made.

Provide a mixture design that is developed and signed by a Level II certified specialist. Provide a Level IA certified specialist at the plant during production operations. Provide a Level IB certified specialist to conduct placement tests.

Table 4
Test Methods, Test Responsibility, and Minimum Certification Levels

1. Aggregate Testing	Test Method	Contractor	Engineer	Level
Sampling	Tex-400-A	✓	✓	IA
Dry sieve	Tex-200-F, Part I	✓	✓	IA
Washed sieve	Tex-200-F, Part II	✓	✓	IA
Deleterious material	Tex-217-F, Part I	✓	✓	II
Decantation	Tex-217-F, Part II	✓	✓	II
Los Angeles abrasion	Tex-410-A		✓	
Magnesium sulfate soundness	Tex-411-A		✓	
Micro-Deval abrasion	Tex-461-A		✓	
Coarse aggregate angularity	Tex-460-A	✓	✓	II
Flat and elongated particles	Tex-280-F	✓	✓	II
Linear shrinkage	Tex-107-E	✓	✓	II
Sand equivalent	Tex-203-F	✓	✓	II
Organic impurities	Tex-408-A	✓	✓	II
2. Mix Design & Verification	Test Method	Contractor	Engineer	Level
Design and JMF changes	Tex-204-F	✓	✓	II
Mixing	Tex-205-F	✓	✓	II
Molding (TGC)	Tex-206-F	✓	✓	IA
Laboratory-molded density	Tex-207-F	✓	✓	IA
VMA (calculation only)	Tex-207-F	✓	✓	II
Rice gravity	Tex-227-F	✓	✓	IA
Ignition oven calibration ¹	Tex-236-F	✓	✓	II
Indirect tensile strength	Tex-226-F	✓	✓	II
Hamburg wheel test	Tex-242-F	✓	✓	II
Boil test	Tex-530-C	✓	✓	IA
3. Production Testing	Test Method	Contractor	Engineer	Level
Random sampling	Tex-225-F		✓	IA
Mixture sampling	Tex-222-F	✓	✓	IA
Molding (TGC)	Tex-206-F	✓	✓	IA
Laboratory-molded density	Tex-207-F	✓	✓	IA
VMA (calculation only)	Tex-207-F	✓	✓	IA
Rice gravity	Tex-227-F	✓	✓	IA
Gradation & asphalt content ¹	Tex-236-F	✓	✓	IA
Control charts	Tex-233-F	✓	✓	IA
Moisture content	Tex-212-F	✓	✓	IA

Table 4 (continued)**Test Methods, Test Responsibility, and Minimum Certification Levels**

3. Production Testing	Test Method	Contractor	Engineer	Level
Hamburg Wheel test	Tex-242-F	✓	✓	II
Micro-Deval abrasion	Tex-461-A		✓	
Boil test	Tex-530-C	✓	✓	IA
Aging ratio	Tex-211-F		✓	
4. Placement Testing	Test Method	Contractor	Engineer	Level
Random Sampling	Tex-225-F		✓	IA
In-Place air voids	Tex-207-F	✓	✓	IA
Establish rolling pattern	Tex-207-F	✓		IB
Control charts	Tex-233-F	✓	✓	IA
Ride quality measurement	Tex-1001-S	✓	✓	IB
Segregation (density profile)	Tex-207-F, Part V	✓	✓	IB
Longitudinal joint density	Tex-207-F, Part VII	✓	✓	IB
Thermal profile	Tex-244-F	✓	✓	IB
Tack coat adhesion	Tex-243-F		✓	IB

1. Refer to Section 341.4.1.2.c for exceptions to using an ignition oven.

- B. Reporting.** Use Department-provided software to record and calculate all test data. The Engineer and the Contractor shall provide any available test results to the other party when requested. The maximum allowable time for the Contractor and Engineer to exchange test data is as given in Table 5 unless otherwise approved. The Engineer and the Contractor shall immediately report to the other party any test result that requires production to be suspended, a payment penalty, or fails to meet the specification requirements. Use the approved communication method (e.g., email, diskette, hard copy) to submit test results to the Engineer.

Table 5
Reporting Schedule

Description	Reported By	Reported To	To Be Reported Within
Production Quality Control			
Gradation ¹ Asphalt content ¹ Laboratory-molded density ² Moisture content ³ Boil test ³	Contractor	Engineer	1 working day of completion of the subplot
Production Quality Assurance			
Gradation ³ Asphalt content ³ Laboratory-molded density ¹ Hamburg wheel test ² Boil test ³ Binder tests ²	Engineer	Contractor	1 working day of completion of the subplot
Placement Quality Control			
In-Place air voids ² Segregation ¹ Longitudinal joint density ¹ Thermal profile ¹	Contractor	Engineer	1 hr. of performing the test for segregation, longitudinal joint density, and thermal profile
Placement Quality Assurance			
In-Place air voids ¹ Segregation ² Longitudinal joint density ² Thermal profile ² Aging ratio ²	Engineer	Contractor	1 working day of receipt of the trimmed cores for in-place air voids ⁴
Pay Adjustment Summary	Engineer	Contractor	2 working days of performing all required tests and receiving Contractor test data

1. These tests are required on every subplot.
2. Optional test. To be reported as soon as results become available.
3. To be performed at the frequency shown in Table 12.
4. Additional time is allowed if cores cannot be dried to constant weight within 1 day.

The Engineer will use the Department-provided software to calculate all pay adjustment factors for the lot. Sublot samples may be discarded after the Engineer and Contractor sign off on the pay adjustment summary documentation for the lot.

Use the procedures described in Tex-233-F to plot the results of all quality control (QC) and quality assurance (QA) testing. Update the control charts as soon as test results for each subplot become available.

341.4 to 341.4

Make the control charts readily accessible at the field laboratory. The Engineer may suspend production for failure to update control charts.

- C. **QCP.** Develop and follow the QCP in detail. Obtain approval from the Engineer for changes to the QCP made during the project. The Engineer may suspend operations if the Contractor fails to comply with the QCP.

Submit a written QCP to the Engineer before the mandatory prepaving meeting. Receive the Engineer's approval of the QCP before beginning production. Include the following items in the QCP.

1. **Project Personnel.** For project personnel, include:
 - a list of individuals responsible for QC with authority to take corrective action and
 - contact information for each individual listed.
2. **Material Delivery and Storage.** For material delivery and storage, include:
 - the sequence of material processing, delivery, and minimum quantities to assure continuous plant operations;
 - aggregate stockpiling procedures to avoid contamination and segregation;
 - frequency, type, and timing of aggregate stockpile testing to assure conformance of material requirements before mixture production; and
 - procedure for monitoring the quality and variability of asphalt binder.
3. **Production.** For production, include:
 - loader operation procedures to avoid contamination in cold bins,
 - procedures for calibrating and controlling cold feeds,
 - procedures to eliminate debris or oversized material,
 - procedures for adding and verifying rates of each applicable mixture component (e.g., aggregate, asphalt binder, RAP, lime, liquid antistriper),
 - procedures for reporting job control test results, and
 - procedures to avoid segregation and drain-down in the silo.
4. **Loading and Transporting.** For loading and transporting, include:
 - type and application method for release agents and
 - truck loading procedures to avoid segregation.

5. Placement and Compaction. For placement and compaction, include:

- proposed agenda for mandatory prepaving meeting including date and location;
- type and application method for release agents in the paver and on rollers, shovels, lutes, and other utensils;
- procedures for the transfer of mixture into the paver while avoiding segregation and preventing material spillage;
- process to balance production, delivery, paving, and compaction to achieve continuous placement operations;
- paver operations (e.g., operation of wings, height of mixture in auger chamber) to avoid physical and thermal segregation and other surface irregularities; and
- procedures to construct quality longitudinal and transverse joints.

D. Mixture Design.

- 1. Design Requirements.** Unless otherwise shown on the plans, use the typical weight design example given in Tex-204-F, Part I, to design a mixture meeting the requirements listed in Tables 1, 2, 3, 6, 7, and 8. Use an approved laboratory to perform the Hamburg Wheel test and provide results with the mixture design or provide the laboratory mixture and request that the Department perform the Hamburg Wheel test. The Construction Division maintains a list of approved laboratories. The Engineer will be allowed 10 working days to provide the Contractor with Hamburg Wheel test results on the laboratory mixture design.

The Contractor may submit a new mixture design at anytime during the project. The Engineer will approve all mixture designs before the Contractor can begin production. When shown on the plans, the Engineer will provide the mixture design.

Provide the Engineer with a mixture design report using Department-provided software. Include the following in the report:

- the combined aggregate gradation, source, specific gravity, and percent of each material used;
- results of all applicable tests;
- the mixing and molding temperatures;
- the signature of the Level II person or persons that performed the design;
- the date the mixture design was performed; and
- a unique identification number for the mixture design.

Table 6
Master Gradation Bands (% Passing by Weight or Volume)
and Volumetric Properties

Sieve Size	A Coarse Base	B Fine Base	C Coarse Surface	D Fine Surface	F Fine Mixture
1-1/2"	98.0–100.0	–	–	–	–
1"	78.0–94.0	98.0–100.0	–	–	–
3/4"	64.0–85.0	84.0–98.0	95.0–100.0	–	–
1/2"	50.0–70.0	–	–	98.0–100.0	–
3/8"	–	60.0–80.0	70.0–85.0	85.0–100.0	98.0–100.0
#4	30.0–50.0	40.0–60.0	43.0–63.0	50.0–70.0	80.0–86.0
#8	22.0–36.0	29.0–43.0	32.0–44.0	35.0–46.0	38.0–48.0
#30	8.0–23.0	13.0–28.0	14.0–28.0	15.0–29.0	12.0–27.0
#50	3.0–19.0	6.0–20.0	7.0–21.0	7.0–20.0	6.0–19.0
#200	2.0–7.0	2.0–7.0	2.0–7.0	2.0–7.0	2.0–7.0
Design VMA¹, % Minimum					
–	12.0	13.0	14.0	15.0	16.0
Plant-Produced VMA, % Minimum					
–	11.0	12.0	13.0	14.0	15.0

1. Voids in mineral aggregates.

Table 7
Laboratory Mixture Design Properties

Mixture Property	Test Method	Requirement
Target laboratory-molded density, %	Tex-207-F	96.0 ¹
Tensile strength (dry), psi (molded to 93% ±1% density)	Tex-226-F	85–200 ²
Boil test ³	Tex-530-C	–

1. Unless otherwise shown on the plans.
2. May exceed 200 psi when approved and may be waived when approved.
3. Used to establish baseline for comparison to production results. May be waived when approved.

Table 8
Hamburg Wheel Test Requirements¹

High-Temperature Binder Grade	Minimum # of PASSES ² @ 0.5" Rut Depth, Tested @ 122°F
PG 64 or lower	10,000
PG 70	15,000
PG 76 or higher	20,000

1. Tested in accordance with Tex-242-F.
2. May be decreased or waived when shown on the plans.

2. **Job-Mix Formula Approval.** The job-mix formula (JMF) is the combined aggregate gradation and target asphalt percentage used to establish target values for hot mix production. JMF1 is the original laboratory mixture design used to produce the trial batch. The Engineer and the Contractor will verify JMF1 based on plant-produced mixture from the trial batch unless otherwise approved. The Engineer may accept an existing mixture design previously used on a Department project and may waive the trial batch to verify JMF1.

a. **Contractor's Responsibilities.**

- (1) **Providing Texas Gyrotory Compactor.** If molding production samples, use a Texas Gyrotory Compactor (TGC) calibrated in accordance with Tex-914-F. When allowed, the Contractor may use the Department's TGC.
- (2) **Gyrotory Compactor Correlation Factors.** Use Tex-206-F, Part II, to perform a gyrotory compactor correlation when the Engineer uses a different TGC. Apply the correlation factor to all subsequent production test results.
- (3) **Submitting JMF1.** Furnish the Engineer a mix design report (JMF1) and request approval to produce the trial batch. If opting to have the Department perform the Hamburg Wheel test on the laboratory mixture, provide the Engineer with approximately 10,000 g of the design mixture and request that the Department perform the Hamburg Wheel test.
- (4) **Supplying Aggregates.** Provide the Engineer with approximately 40 lb. of each aggregate stockpile unless otherwise directed.
- (5) **Supplying Asphalt.** Provide the Engineer at least 1 gal. of the asphalt material and sufficient quantities of any additives proposed for use.
- (6) **Ignition Oven Correction Factors.** Determine the aggregate and asphalt correction factors from the ignition oven using Tex-236-F. Provide the Engineer with split samples of the mixtures and blank samples used to determine the correction factors.
- (7) **Boil Test.** Perform the test and retain the tested sample from Tex-530-C. Use this sample for comparison

purposes during production. The Engineer may waive the requirement for the boil test.

- (8) **Trial Batch Approval.** Upon receiving conditional approval of JMF1 from the Engineer, provide a plant-produced trial batch for verification testing of JMF1 and development of JMF2.
- (9) **Trial Batch Production Equipment.** To produce the trial batch, use only equipment and materials proposed for use on the project.
- (10) **Trial Batch Quantity.** Produce enough quantity of the trial batch to ensure that the mixture is representative of JMF1.
- (11) **Number of Trial Batches.** Produce trial batches as necessary to obtain a mixture that meets the requirements in Table 9.
- (12) **Trial Batch Sampling.** Obtain a representative sample of the trial batch and split it into 3 equal portions in accordance with Tex-222-F. Label these portions as “Contractor,” “Engineer,” and “Referee.” Deliver samples to the appropriate laboratory as directed.
- (13) **Trial Batch Testing.** Test the trial batch to ensure the mixture produced using the proposed JMF1 meets the verification testing requirements for gradation, asphalt content, laboratory-molded density, and voids in mineral aggregates (VMA) listed in Table 9 and is in compliance with the Hamburg Wheel test requirement in Table 8. Use an approved laboratory to perform the Hamburg Wheel test on the trial batch mixture or request that the Department perform the Hamburg Wheel test. The Engineer will be allowed 10 working days to provide the Contractor with Hamburg Wheel test results on the trial batch. Provide the Engineer with a copy of the trial batch test results.
- (14) **Development of JMF2.** After the Engineer grants full approval of JMF1 based on results from the trial batch, evaluate the trial batch test results, determine the optimum mixture proportions, and submit as JMF2.
- (15) **Mixture Production.** After receiving approval for JMF2 and receiving a passing result from the Department’s or

an approved laboratory's Hamburg Wheel test on the trial batch, use JMF2 to produce Lot 1 as described in Section 341.4.I.3.a(1), "Lot 1 Placement." As an option, once JMF2 is approved, proceed to Lot 1 production at the Contractor's risk without receiving the results from the Department's Hamburg Wheel test on the trial batch.

If electing to proceed without Hamburg Wheel test results from the trial batch, notify the Engineer. Note that the Engineer may require up to the entire subplot of any mixture failing the Hamburg Wheel test to be removed and replaced at the Contractor's expense.

- (16) **Development of JMF3.** Evaluate the test results from Lot 1, determine the optimum mixture proportions, and submit as JMF3 for use in Lot 2.
- (17) **JMF Adjustments.** If necessary, adjust the JMF before beginning a new lot. The adjusted JMF must:
- be provided to the Engineer in writing before the start of a new lot,
 - be numbered in sequence to the previous JMF,
 - meet the master gradation limits shown in Table 6, and
 - be within the operational tolerances of JMF2 listed in Table 9.
- (18) **Requesting Referee Testing.** If needed, use referee testing in accordance with Section 341.4.I.1, "Referee Testing," to resolve testing differences with the Engineer.

Table 9
Operational Tolerances

Description	Test Method	Allowable Difference from Current JMF Target	Allowable Difference between Contractor and Engineer ¹
Individual % retained for #8 sieve and larger	Tex-200-F or Tex-236-F	±5.0 ²	±5.0
Individual % retained for sieves smaller than #8 and larger than #200		±3.0 ²	±3.0
% passing the #200 sieve	Tex-236-F	±2.0 ²	±1.6
Asphalt content, %	Tex-236-F	±0.3 ³	±0.3
Laboratory-molded density, %	Tex-207-F	±1.0	±1.0
In-Place air voids, %		N/A	±1.0
Laboratory-molded bulk specific gravity		N/A	±0.020
VMA, %, min		Note 4	N/A
Theoretical maximum specific (Rice) gravity	Tex-227-F	N/A	±0.020

1. Contractor may request referee testing only when values exceed these tolerances.
2. When within these tolerances, mixture production gradations may fall outside the master grading limits; however, the % passing the #200 will be considered out of tolerance when outside the master grading limits.
3. Tolerance between JMF1 and JMF2 may exceed ±0.3%.
4. Test and verify that Table 6 requirements are met.

b. Engineer's Responsibilities.

- (1) **Gyratory Compactor.** The Engineer will use a Department TGC, calibrated according to Tex-914-F, to mold samples for trial batch and production testing. The Engineer will make the Department TGC and the Department field laboratory available to the Contractor for molding verification samples, if requested by the Contractor.
- (2) **Conditional Approval of JMF1.** Within 2 working days of receiving the mixture design report (JMF1) and all required materials and Contractor-provided Hamburg Wheel test results, the Engineer will review the Contractor's mix design report and verify conformance with all aggregates, asphalt, additives, and mixture specifications. The Engineer may perform tests to verify the aggregates meet the requirements listed in Table 1. The Engineer will grant the Contractor conditional approval of JMF1 if the information provided on the paper copy of JMF1 indicates the Contractor's mixture design meets the specifications. When the Contractor does

not provide Hamburg Wheel test results with laboratory mixture design, a total of 10 working days is allowed for conditional approval of JMF1. Full approval of JMF1 will be based on the Engineer's test results on mixture from the trial batch.

- (3) **Hamburg Wheel Testing of JMF1.** If the Contractor requests the option to have the Department perform the Hamburg Wheel test on the laboratory mixture, the Engineer will mold samples in accordance with Tex-242-F to verify compliance with the Hamburg Wheel test requirement in Table 8.
- (4) **Authorizing Trial Batch.** After conditionally approving JMF1, which will include either Contractor- or Department-supplied Hamburg Wheel test results, the Engineer will authorize the Contractor to produce a trial batch.
- (5) **Ignition Oven Correction Factors.** The Engineer will use the split samples provided by the Contractor to determine the aggregate and asphalt correction factors for the ignition oven in accordance with Tex-236-F.
- (6) **Testing the Trial Batch.** Within 1 full working day, the Engineer will sample and test the trial batch to ensure that the gradation, asphalt content, laboratory-molded density, and VMA meet the requirements listed in Table 9. If the Contractor requests the option to have the Department perform the Hamburg Wheel test on the trial batch mixture, the Engineer will mold samples in accordance with Tex-242-F to verify compliance with the Hamburg Wheel test requirement in Table 8.

The Engineer will have the option to perform the following tests on the trial batch:

- Tex-226-F to verify that the indirect tensile strength meets the requirement shown in Table 7;
 - Tex-461-A to determine the need for additional magnesium sulfate soundness testing; and
 - Tex-530-C to retain and use for comparison purposes during production.
- (7) **Full Approval of JMF1.** The Engineer will grant full approval of JMF1 and authorize the Contractor to proceed with developing JMF2 if the Engineer's results for

341.4 to 341.4

gradation, asphalt content, laboratory-molded density, and VMA confirm that the trial batch meets the requirements in Table 9.

The Engineer will notify the Contractor that an additional trial batch is required if the trial batch does not meet the requirements in Table 9.

- (8) **Approval of JMF2.** The Engineer will approve JMF2 within 1 working day if it meets the master grading limits shown in Table 6 and is within the operational tolerances of JMF1 listed in Table 9.
- (9) **Approval of Lot 1 Production.** The Engineer will authorize the Contractor to proceed with Lot 1 production as soon as a passing result is achieved from the Department's or a Department-approved laboratory's Hamburg Wheel test on the trial batch. As an option, the Contractor may at their own risk, proceed with Lot 1 production without the results from the Hamburg Wheel test on the trial batch.

If the Department's or Department-approved laboratory's sample from the trial batch fails the Hamburg Wheel test, the Engineer will suspend production until further Hamburg Wheel tests meet the specified values. The Engineer may require up to the entire subplot of any mixture failing the Hamburg Wheel test be removed and replaced at the Contractor's expense.

- (10) **Approval of JMF3.** The Engineer will approve JMF3 within 1 working day if it meets the master grading limits shown in Table 6 and is within the operational tolerances of JMF2 listed in Table 9.

E. Production Operations. Perform a new trial batch when the plant or plant location is changed. Take corrective action and receive approval to proceed after any production suspension for noncompliance with this Item.

- 1. **Storage and Heating of Materials.** Do not heat the asphalt binder above the temperatures specified in Item 300, "Asphalts, Oils, and Emulsions," or outside the manufacturer's recommended values. On a daily basis, provide the Engineer with the records of asphalt binder and hot-mix asphalt discharge temperatures in accordance with Item 320, "Equipment for Asphalt Concrete Pavement."

Unless otherwise approved, do not store mixture for a period long enough to affect the quality of the mixture, nor in any case longer than 12 hr.

2. **Mixing and Discharge of Materials.** Notify the Engineer of the target discharge temperature and produce the mixture within 25°F of the target. Monitor the temperature of the material in the truck before shipping to ensure that it does not exceed 350°F. The Department will not pay for or allow placement of any mixture produced at more than 350°F.

Control the mixing time and temperature so that substantially all moisture is removed from the mixture before discharging from the plant. If requested, determine the moisture content by oven-drying in accordance with Tex-212-F, Part II, and verify that the mixture contains no more than 0.2% of moisture by weight. Obtain the sample immediately after discharging the mixture into the truck, and perform the test promptly.

- F. **Hauling Operations.** Before use, clean all truck beds to ensure mixture is not contaminated. When a release agent is necessary to coat truck beds, use a release agent on the approved list maintained by the Construction Division.
- G. **Placement Operations.** Prepare the surface by removing raised pavement markers and objectionable material such as moisture, dirt, sand, leaves, and other loose impediments from the surface before placing mixture. Remove vegetation from pavement edges. Place the mixture to meet the typical section requirements and produce a smooth, finished surface with a uniform appearance and texture. Offset longitudinal joints of successive courses of hot mix by at least 6 in. Place mixture so longitudinal joints on the surface course coincide with lane lines, or as directed. Ensure that all finished surfaces will drain properly. Place mixture within the compacted lift thickness shown in Table 10 unless otherwise shown on the plans or allowed.

Table 10
Compacted Lift Thickness and Required Core Height

Mixture Type	Compacted Lift Thickness		Minimum Untrimmed Core Height (in.) Eligible for Testing
	Minimum (in.)	Maximum (in.)	
A	3.00	6.00	2.00
B	2.50	5.00	1.75
C	2.00	4.00	1.50
D	1.50	3.00	1.25
F	1.25	2.50	1.25

1. **Weather Conditions.** Place mixture when the roadway surface temperature is 60°F or higher unless otherwise approved. Measure the roadway surface temperature with a handheld infrared thermometer. Unless otherwise shown on the plans, place mixtures only when weather conditions and moisture conditions of the roadway surface are suitable in the opinion of the Engineer.
2. **Tack Coat.** Clean the surface before placing the tack coat. Unless otherwise approved, apply tack coat uniformly at the rate directed by the Engineer. The Engineer will set the rate between 0.04 and 0.10 gal. of residual asphalt per square yard of surface area. Apply a thin, uniform tack coat to all contact surfaces of curbs, structures, and all joints. Prevent splattering of tack coat when placed adjacent to curb, gutter, and structures. Roll the tack coat with a pneumatic-tire roller when directed. The Engineer may use Tex-243-F to verify that the tack coat has adequate adhesive properties. The Engineer may suspend paving operations until there is adequate adhesion.
3. **Lay-Down Operations.** Use the guidelines in Table 11 to establish the temperature of mixture delivered to the paver. Record the information on Department QC/QA forms and submit the forms to the Engineer.
 - a. **Thermal Profile.** For each subplot, obtain a thermal profile using Tex-244-F. The Engineer may reduce the testing frequency based on a satisfactory test history. The Engineer may also obtain as many thermal profiles as deemed necessary. If the temperature differential is greater than 25°F, the area will be deemed as having thermal segregation. Evaluate areas with thermal segregation by performing a density profile in accordance with Section 341.4.I.3.c(2), “Segregation (Density Profile).” Take corrective action to eliminate areas that have thermal segregation. Unless

otherwise directed, suspend operations if the maximum temperature differential exceeds 50°F. Resume operations when the Engineer determines that subsequent production will meet the requirements of this Item.

- b. Windrow Operations.** When hot mix is placed in windrows, operate windrow pickup equipment so that substantially all the mixture deposited on the roadbed is picked up and loaded into the paver.

Table 11
Suggested Minimum Mixture Placement Temperature

High Temperature Binder Grade	Minimum Placement Temperature (Before Entering Paver)
PG 64 or lower	260°F
PG 70	270°F
PG 76	280°F
PG 82 or higher	290°F

- H. Compaction.** Uniformly compact the pavement to the density requirements of this Item. Use the control strip method given in Tex-207-F, Part IV, to establish the rolling pattern. Do not use pneumatic-tire rollers if excessive pickup of fines by roller tires occurs. Unless otherwise directed, use only water or an approved release agent on rollers, tamps, and other compaction equipment.

Where specific air void requirements are waived, furnish and operate compaction equipment as approved. Use tamps to thoroughly compact the edges of the pavement along curbs, headers, and similar structures and in locations that will not allow thorough compaction with rollers. The Engineer may require rolling with a trench roller on widened areas, in trenches, and in other limited areas.

Allow the compacted pavement to cool to 160°F or lower before opening to traffic unless otherwise directed. When directed, sprinkle the finished mat with water or limewater to expedite opening the roadway to traffic.

- I. Acceptance Plan.** Pay adjustments for the material will be in accordance with Article 341.6, "Payment."

Sample and test the hot mix on a lot and subplot basis. If the production pay factor given in Section 341.6.A, "Production Pay Adjustment Factors," for 3 consecutive lots or the placement pay factor given in 341.6.B, "Placement Pay Adjustment Factors," for 3 consecutive lots is below 1.000, suspend production until test results or other information

341.4 to 341.4

indicate to the satisfaction of the Engineer that the next material produced or placed will result in pay factors of at least 1.000.

1. **Referee Testing.** The Construction Division is the referee laboratory. The Contractor may request referee testing if a “remove and replace” condition is determined based on the Engineer’s test results, or if the differences between Contractor and Engineer test results exceed the maximum allowable difference shown in Table 9 and the differences cannot be resolved. Make the request within 5 working days after receiving test results and cores from the Engineer. Referee tests will be performed only on the subplot in question and only for the particular test in question. Allow 10 working days from the time the samples are received at the referee laboratory for test results to be reported. The Department may require the Contractor to reimburse the Department for referee tests if more than 3 referee tests per project are required and the Engineer’s test results are closer than the Contractor’s test results to the referee test results.

The Construction Division will determine the laboratory-molded density based on the molded specific gravity and the maximum theoretical specific gravity of the referee sample. The in-place air voids will be determined based on the bulk specific gravity of the cores, as determined by the referee laboratory, and the Engineer’s average maximum theoretical specific gravity for the lot. With the exception of remove and replace conditions, referee test results are final and will establish pay adjustment factors for the subplot in question. Sublots subject to be removed and replaced will be further evaluated in accordance with Article 341.6, “Payment.”

2. **Production Acceptance.**
 - a. **Production Lot.** A production lot consists of 4 equal sublots. Lot 1 will be 1,000 tons. The Engineer will select subsequent lot sizes based on the anticipated daily production. The lot size will be between 1,000 and 4,000 tons. The Engineer may change the lot size before the Contractor begins any lot.
 - (1) **Small-Quantity Production.** When the anticipated daily production is less than 500 tons or the total production for the project is less than 5,000 tons, the Engineer may waive all quality control and quality assurance (QC/QA) sampling and testing requirements. If the Engineer waives QC/QA sampling and testing, both production and placement pay factors will be 1.000. However, the

Engineer will retain the right to perform random acceptance tests for production and placement and may reject objectionable materials and workmanship.

When the Engineer waives all QC/QA sampling and testing requirements:

- produce, haul, place and compact the mixture as directed by the Engineer;
- control mixture production to yield a laboratory-molded density of 96.0% \pm 1.0% as tested by the Engineer; and
- compact the mixture to yield in-place air voids that are greater than or equal to 2.7% and less than or equal to 9.9% as tested by the Engineer.

- (2) **Incomplete Production Lots.** If a lot is begun but cannot be completed, such as on the last day of production or in other circumstances deemed appropriate, the Engineer may close the lot. Adjust the payment for the incomplete lot in accordance with Section 341.6.A, "Production Pay Adjustment Factors."

b. Production Sampling.

- (1) **Mixture Sampling.** At the beginning of the project, the Engineer will select random numbers for all production sublots. Determine sample locations in accordance with Tex-225-F.

Obtain hot mix samples from trucks at the plant in accordance with Tex-222-F. For each subplot, take 1 sample at the location randomly selected. For each lot, the Engineer will randomly select and test a "blind" sample from at least 1 subplot. The location of the Engineer's "blind" sample will not be disclosed to the Contractor. The Engineer will use the Contractor's split sample for sublots not sampled by the Engineer.

The sampler will split each sample into 3 equal portions in accordance with Tex-200-F, and label these portions as "Contractor," "Engineer," and "Referee." Deliver the samples to the appropriate party's laboratory. Deliver referee samples to the Engineer. Discard unused samples after accepting pay adjustment factors for that lot.

- (2) **Asphalt Binder Sampling.** Obtain a 1-qt. sample of the asphalt binder for each subplot of mixture produced. Obtain the sample at approximately the same time the mixture random sample is obtained. Sample from a port located immediately upstream from the mixing drum or pug mill. Take the sample in accordance with the pipeline sampling procedure given in Tex-500-C, Part II. Label the can with the corresponding lot and subplot numbers, and deliver the sample to the Engineer.

The Engineer may also obtain independent samples. If the Engineer chooses to obtain an independent asphalt binder sample, the Engineer will split a sample of the asphalt binder with the Contractor. The Engineer will test at least 1 asphalt binder sample per project to verify compliance with Item 300, "Asphalts, Oils, and Emulsions."

- c. **Production Testing.** The Contractor and Engineer must perform production tests in accordance with Table 12. The Contractor has the option to verify the Engineer's test results on split samples provided by the Engineer. Determine compliance with operational tolerances listed in Table 9 for all sublots.

If the aggregate mineralogy is such that Tex-236-F does not yield reliable results, the Engineer may allow alternate methods for determining the asphalt content and aggregate gradation. Unless otherwise allowed, the Engineer will require the Contractor to provide evidence that results from Tex-236-F are not reliable before permitting an alternate method. If an alternate test method is allowed, use the applicable test procedure as directed.

Table 12
Production and Placement Testing Frequency

Description	Test Method	Minimum Contractor Testing Frequency	Minimum Engineer Testing Frequency
Individual % retained for #8 sieve and larger Individual % retained for sieves smaller than #8 and larger than #200 % passing the #200 sieve	Tex-200-F or Tex-236-F	1 per sublot	1 per 12 sublots
Asphalt content	Tex-236-F	1 per sublot	1 per lot
Laboratory-molded density VMA In-Place air voids Laboratory-molded bulk specific gravity	Tex-207-F	N/A	1 per sublot
Theoretical maximum specific (Rice) gravity	Tex-227-F	N/A	1 per sublot
Hamburg Wheel test	Tex-242-F	N/A	1 per project
Boil test ¹	Tex-530-C	1 per lot	1 per project
Moisture content	Tex-212-F, Part II	When directed	1 per project
Asphalt binder sampling and testing ¹	Tex-500-C	1 per sublot (sample only)	1 per project
Thermal profile	Tex-244-F	1 per sublot	1 per project
Segregation (density profile)	Tex-207-F, Part V	1 per sublot	1 per project
Longitudinal joint density	Tex-207-F, Part VII	1 per sublot	1 per project

1. The Engineer may reduce or waive the sampling and testing requirements based on a satisfactory test history.

d. Operational Tolerances. Control the production process within the operational tolerances listed in Table 9. When production is suspended, the Engineer will allow production to resume when test results or other information indicates the next mixture produced will be within the operational tolerances.

- (1) **Gradation.** Unless otherwise directed, suspend production when either the Contractor's or the Engineer's test results for gradation exceed the operational tolerances for 3 consecutive sublots on the same sieve or 4 consecutive sublots on any sieve. The consecutive sublots may be from more than 1 lot.
- (2) **Asphalt Content.** No production or placement bonus will be paid for any lot that has 2 or more sublots within a lot that are out of operational tolerance for asphalt content

based on either the Contractor's or the Engineer's test results. Suspend production and shipment of mixture if the asphalt content deviates from the current JMF by more than 0.5% for any subplot.

- (3) **Hamburg Wheel Test.** The Engineer may perform a Hamburg Wheel test at any time during production, including when the boil test indicates a change in quality from the materials submitted for JMF1. In addition to testing production samples, the Engineer may obtain cores and perform Hamburg Wheel tests on any areas of the roadway where rutting is observed. When the production or core samples fail the Hamburg Wheel test criteria in Table 8, suspend production until further Hamburg Wheel tests meet the specified values. Core samples, if taken, will be obtained from the center of the finished mat or other areas excluding the vehicle wheel paths. The Engineer may require up to the entire subplot of any mixture failing the Hamburg Wheel test to be removed and replaced at the Contractor's expense.

If the Department's or approved laboratory's Hamburg Wheel test results in a "remove and replace" condition, the Contractor may request that the Department confirm the results by retesting the failing material. The Construction Division will perform the Hamburg Wheel tests and determine the final disposition of the material in question based on the Department's test results.

- e. **Individual Loads of Hot Mix.** The Engineer can reject individual truckloads of hot mix. When a load of hot mix is rejected for reasons other than temperature, the Contractor may request that the rejected load be tested. Make this request within 4 hr. of rejection. The Engineer will sample and test the mixture. If test results are within the operational tolerances shown in Table 9, payment will be made for the load. If test results are not within operational tolerances, no payment will be made for the load and the Engineer may require removal.

3. Placement Acceptance.

- a. **Placement Lot.** A placement lot consists of 4 placement sublots. A placement subplot consists of the area placed during a production subplot.

- (1) **Lot 1 Placement.** Placement bonuses for Lot 1 will be in accordance with Section 341.6.B, “Placement Pay Adjustment Factors.” However, no placement penalty will be assessed for any subplot placed in Lot 1 when the in-place air voids are greater than or equal to 2.7% and less than or equal to 9.9%. Remove and replace any subplot with in-place air voids less than 2.7% or greater than 9.9%.
 - (2) **Incomplete Placement Lots.** An incomplete placement lot consists of the area placed as described in Section 341.4.1.2.a(2), “Incomplete Production Lot,” excluding miscellaneous areas as defined in Section 344.4.1.3.a(4), “Miscellaneous Areas.” Placement sampling is required if the random sample plan for production resulted in a sample being obtained from an incomplete production subplot.
 - (3) **Shoulders and Ramps.** Shoulders and ramps are subject to in-place air void determination and pay adjustments unless otherwise shown on the plans.
 - (4) **Miscellaneous Areas.** Miscellaneous areas include areas that are not generally subject to primary traffic such as driveways, mailbox turnouts, crossovers, gores, spot level-up areas, and other similar areas. Miscellaneous areas also include level-ups and thin overlays if the layer thickness designated on the plans is less than the compacted lift thickness shown in Table 10. Miscellaneous areas are not eligible for random placement sampling locations, and will receive a 1.000 placement pay factor. Compact areas that are not subject to in-place air void determination in accordance with Section 341.4.H, “Compaction.”
- b. Placement Sampling.** At the beginning of the project, the Engineer will select random numbers for all placement sublots. The Engineer will provide the Contractor with the placement random numbers immediately after the subplot is completed. Mark the roadway location at the completion of each subplot and record the station number. Determine 1 random sample location for each placement subplot in accordance with Tex-225-F. If the randomly generated sample location is within 2 ft. of a joint or pavement edge, adjust the

341.4 to 341.4

location by no more than necessary to achieve a 2-ft. clearance.

Shoulders and ramps are always eligible for selection as a random sample location. However, if a random sample location falls on a shoulder or ramp that is designated on the plans as not subject to in-place air void testing, cores will not be taken for the subplot and a 1.000 pay factor will be assigned to that subplot.

Unless otherwise determined, the Engineer will witness the coring operation and measurement of the core thickness. Unless otherwise approved, obtain the cores within 1 working day of the time the placement subplot is completed. Obtain two 6-in.-diameter cores side-by-side from within 1 ft. of the random location provided for the placement subplot. Mark the cores for identification. Visually inspect each core and verify that the current paving layer is bonded to the underlying layer. If an adequate bond does not exist between the current and underlying layer, take corrective action to insure that an adequate bond will be achieved during subsequent placement operations. For Type D and Type F mixtures, 4-in.-diameter cores are allowed.

Immediately after obtaining the cores, dry the core holes and tack the sides and bottom. Fill the hole with the same type of mixture and properly compact the mixture. Repair core holes with other methods when approved.

If the core heights exceed the minimum untrimmed values listed in Table 10, trim and deliver the cores to the Engineer within 1 working day following placement operations unless otherwise approved.

If the core height before trimming is less than the minimum untrimmed value shown in Table 10, decide whether to include the pair of cores in the air void determination for that subplot. If the cores are to be included in air void determination, trim the cores before delivering to the Engineer. If the cores will not be included in air void determination, deliver untrimmed cores to the Engineer. The placement pay factor for the subplot will be 1.000 if cores will not be included in air void determination.

- c. **Placement Testing.** Perform placement tests in accordance with Table 12. After the Engineer returns the cores, the

Contractor has the option to test the cores to verify the Engineer's test results for in-place air voids. Re-dry the cores to constant weight before testing. The allowable differences between the Contractor's and Engineer's test results are listed in Table 9.

- (1) **In-Place Air Voids.** The Engineer will measure in-place air voids in accordance with Tex-207-F and Tex-227-F. Before drying to a constant weight, cores may be predried using a Corelok or similar vacuum device to remove excess moisture. The Engineer will average the values obtained for all sublots in the production lot to determine the theoretical maximum specific gravity. The Engineer will use the average air void content of the 2 cores to calculate a placement pay adjustment factor.

The Engineer will use paraffin coating or vacuum methods to seal the core if required by Tex-207-F. The Engineer will use the test results from the unsealed core to determine the placement pay adjustment factor if the sealed core yields a higher specific gravity than the unsealed core. After determining the in-place air void content, the Engineer will return the cores and provide test results to the Contractor.

- (2) **Segregation (Density Profile).** Test for segregation using density profiles in accordance with Tex-207-F, Part V. Provide the Engineer with the results of the density profiles as they are completed. Areas defined in Section 341.4.I.3.a(4), "Miscellaneous Areas," are not subject to density profile testing.

Unless otherwise approved, perform a density profile every time the screed stops, on areas that are identified by either the Contractor or the Engineer as having thermal segregation, and on any visibly segregated areas. If the screed does not stop, and there are no visibly segregated areas or areas that are identified as having thermal segregation, perform a minimum of 1 profile per subplot. Reduce the test frequency to a minimum of 1 profile per lot if 4 consecutive profiles are within established tolerances. Continue testing at a minimum frequency of 1 per lot unless a profile fails, at which point resume testing at a minimum frequency of 1 per subplot. The Engineer

may further reduce the testing frequency based on a consistent pattern of satisfactory results.

The density profile is considered failing if it exceeds the tolerances in Table 13. No production or placement bonus will be paid for any subplot that contains a failing density profile. The Engineer may make as many independent density profile verifications as deemed necessary. The Engineer’s density profile results will be used when available.

Investigate density profile failures and take corrective actions during production and placement to eliminate the segregation. Suspend production if 2 consecutive density profiles fail, unless otherwise approved. Resume production after the Engineer approves changes to production or placement methods.

**Table 13
Segregation (Density Profile) Acceptance Criteria**

Mixture Type	Maximum Allowable Density Range (Highest to Lowest)	Maximum Allowable Density Range (Average to Lowest)
Type A & Type B	8.0 pcf	5.0 pcf
Type C, Type D & Type F	6.0 pcf	3.0 pcf

(3) Longitudinal Joint Density.

(a) Informational Tests. While establishing the rolling pattern, perform joint density evaluations and verify that the joint density is no more than 3.0 pcf below the density taken at or near the center of the mat. Adjust the rolling pattern if needed to achieve the desired joint density. Perform additional joint density evaluations at least once per subplot unless otherwise directed.

(b) Record Tests. For each subplot, perform a joint density evaluation at each pavement edge that is or will become a longitudinal joint. Determine the joint density in accordance with Tex-207-F, Part VII. Record the joint density information and submit results, on Department forms, to the Engineer. The evaluation is considered failing if the joint density is more than 3.0 pcf below the density taken at the core

random sample location and the correlated joint density is less than 90.0%. The Engineer may make independent joint density verifications at the random sample locations. The Engineer's joint density test results will be used when available.

Investigate joint density failures and take corrective actions during production and placement to improve the joint density. Suspend production if 2 consecutive evaluations fail unless otherwise approved. Resume production after the Engineer approves changes to production or placement methods.

- (4) Recovered Asphalt Dynamic Shear Rheometer (DSR).** The Engineer may take production samples or cores from suspect areas of the project to determine recovered asphalt properties. Asphalt binders with an aging ratio greater than 3.5 do not meet the requirements for recovered asphalt properties and may be deemed defective when tested and evaluated by the Construction Division. The aging ratio is the DSR value of the extracted binder divided by the DSR value of the original unaged binder (including RAP binder). DSR values are obtained according to AASHTO T 315 at the specified high temperature PG of the asphalt. The binder from RAP will be included proportionally as part of the original unaged binder. The Engineer may require removal and replacement of the defective material at the Contractor's expense. The asphalt binder will be recovered for testing from production samples or cores using Tex-211-F.
- (5) Irregularities.** Immediately take corrective action if surface irregularities, including but not limited to segregation, rutting, raveling, flushing, fat spots, mat slippage, color, texture, roller marks, tears, gouges, streaks, or uncoated aggregate particles, are detected. The Engineer may allow placement to continue for at most 1 day of production while taking appropriate action. If the problem still exists after that day, suspend paving until the problem is corrected to the satisfaction of the Engineer.
- At the expense of the Contractor and to the satisfaction of the Engineer, remove and replace any mixture that does

341.5 to 341.6

not bond to the existing pavement or that has other surface irregularities identified above.

4. **Ride Quality.** Unless otherwise shown on the plans, measure ride quality in accordance with Item 585, “Ride Quality for Pavement Surfaces.”

341.5. Measurement. Hot mix will be measured by the ton of composite hot mix, which includes asphalt, aggregate, and additives. Measure the weight on scales in accordance with Item 520, “Weighing and Measuring Equipment.”

341.6. Payment. The work performed and materials furnished in accordance with this Item and measured as provided under Article 341.5, “Measurement,” will be paid for at the unit price bid for “Dense-Graded Hot-Mix Asphalt (QC/QA)” of the type, surface aggregate classification, and binder specified. Pay adjustments for bonuses and penalties will be applied as determined in this Item. These prices are full compensation for surface preparation, materials including tack coat, placement, equipment, labor, tools, and incidentals.

Trial batches will not be paid for unless they are included in pavement work approved by the Department.

Pay adjustment for ride quality will be determined in accordance with Item 585, “Ride Quality for Pavement Surfaces.”

- A. **Production Pay Adjustment Factors.** The production pay adjustment factor is based on the laboratory-molded density using the Engineer’s test results. A pay adjustment factor will be determined from Table 14 for each subplot using the deviation from the target laboratory-molded density defined in Table 7. The production pay adjustment factor for completed lots will be the average of the pay adjustment factors for the 4 sublots sampled within that lot.

Table 14
Production Pay Adjustment Factors
for Laboratory-Molded Density

Absolute Deviation from Target Laboratory-Molded Density	Production Pay Adjustment Factor
0.0	1.050
0.1	1.050
0.2	1.050
0.3	1.044
0.4	1.038
0.5	1.031
0.6	1.025
0.7	1.019
0.8	1.013
0.9	1.006
1.0	1.000
1.1	0.965
1.2	0.930
1.3	0.895
1.4	0.860
1.5	0.825
1.6	0.790
1.7	0.755
1.8	0.720
> 1.8	Remove and replace

1. **Incomplete Production Lots.** Production pay adjustments for incomplete lots, described under Section 341.4.I.2.a(2), “Incomplete Production Lots,” will be calculated using the average production pay factors from all sublots sampled. A production pay factor of 1.000 will be assigned to any lot when the random sampling plan did not result in collection of any samples.
 2. **Production Sublots Subject to Removal and Replacement.** If after referee testing, the laboratory-molded density for any subplot results in a “remove and replace” condition as listed in Table 14, the Engineer may require removal and replacement, or may allow the subplot to be left in place without payment. Replacement material meeting the requirements of this Item will be paid for in accordance with this Article.
- B. Placement Pay Adjustment Factors.** The placement pay adjustment factor is based on in-place air voids using the Engineer’s test results. A pay adjustment factor will be determined from Table 15 for each subplot that requires in-place air void measurement. A placement pay adjustment factor of 1.000 will be assigned to the entire subplot when

341.6 to 341.6

the random sample location falls in an area on a ramp or shoulder not subject to in-place air void testing. A placement pay adjustment factor of 1.000 will be assigned to quantities placed in miscellaneous areas as described in Section 341.4.I.3.a(4), "Miscellaneous Areas." The placement pay adjustment factor for completed lots will be the average of the placement pay adjustment factors for the 4 sublots within that lot.

1. **Incomplete Placement Lots.** Pay adjustments for incomplete placement lots described under Section 341.4.I.3.a(2), "Incomplete Placement Lots," will be calculated using the average of the placement pay factors from all sublots sampled and sublots where the random location falls in an area on a ramp or shoulder not eligible for testing. A placement pay adjustment factor of 1.000 will be assigned to any lot when the random sampling plan did not result in collection of any samples.
 2. **Placement Sublots Subject to Removal and Replacement.** If after referee testing the placement pay adjustment factor for any subplot results in a "remove and replace" condition as listed in Table 15, the Engineer will choose the location of 2 cores to be taken within 3 ft. of the original failing core location. The Contractor will obtain the cores in the presence of the Engineer. The Engineer will submit the cores to the Materials and Pavements Section of the Construction Division where they will be tested for bulk specific gravity within 10 working days of receipt. The average bulk specific gravity of the cores will be divided by the Engineer's average maximum theoretical specific gravity for that lot to determine the new pay adjustment factor of the subplot in question. If the new pay adjustment factor is 0.700 or greater, then the new pay adjustment factor will apply to that subplot. If the new pay adjustment factor is less than 0.700, no payment will be made for the subplot. Remove and replace the failing subplot. Replacement material meeting the requirements of this Item will be paid for in accordance with this Article.
- C. **Total Adjustment Pay Calculation.** Total adjustment pay (TAP) will be based on the applicable pay adjustment factors for production and placement for each lot.

$$TAP = (A+B)/2$$

where:

A = Bid price \times production lot quantity \times average pay adjustment factor for the production lot

B = Bid price \times placement lot quantity \times average pay adjustment

factor for the placement lot + (bid price × miscellaneous quantities × 1.000).

Table 15
Placement Pay Adjustment Factors for In-Place Air Voids

In-Place Air Voids	Placement Pay Adjustment Factor	In-Place Air Voids	Placement Pay Adjustment Factor
< 2.7	Remove and Replace	6.4	1.042
2.7	0.705	6.5	1.040
2.8	0.720	6.6	1.038
2.9	0.735	6.7	1.036
3.0	0.750	6.8	1.034
3.1	0.765	6.9	1.032
3.2	0.780	7.0	1.030
3.3	0.795	7.1	1.028
3.4	0.810	7.2	1.026
3.5	0.825	7.3	1.024
3.6	0.840	7.4	1.022
3.7	0.855	7.5	1.020
3.8	0.870	7.6	1.018
3.9	0.885	7.7	1.016
4.0	0.900	7.8	1.014
4.1	0.915	7.9	1.012
4.2	0.930	8.0	1.010
4.3	0.945	8.1	1.008
4.4	0.960	8.2	1.006
4.5	0.975	8.3	1.004
4.6	0.990	8.4	1.002
4.7	1.005	8.5	1.000
4.8	1.020	8.6	0.998
4.9	1.035	8.7	0.996
5.0	1.050	8.8	0.994
5.1	1.050	8.9	0.992
5.2	1.050	9.0	0.990
5.3	1.050	9.1	0.960
5.4	1.050	9.2	0.930
5.5	1.050	9.3	0.900
5.6	1.050	9.4	0.870
5.7	1.050	9.5	0.840
5.8	1.050	9.6	0.810
5.9	1.050	9.7	0.780
6.0	1.050	9.8	0.750
6.1	1.048	9.9	0.720
6.2	1.046	> 9.9	Remove and Replace
6.3	1.044		

ITEM 342

PERMEABLE FRICTION COURSE (PFC)

342.1. Description. Construct a surface course composed of a compacted permeable mixture of aggregate, asphalt binder, and additives mixed hot in a mixing plant.

342.2. Materials. Furnish uncontaminated materials of uniform quality throughout that meet the requirements of the plans and specifications.

Notify the Engineer of all material sources. Notify the Engineer before changing any material source or formulation. When the Contractor makes a source or formulation change, the Engineer will verify that the specification requirements are met and may require a new laboratory mixture design, trial batch, or both. The Engineer may sample and test project materials at any time during the project to verify specification compliance.

A. Aggregate. Furnish aggregates from sources that conform to the requirements shown in Table 1, and as specified in this Section, unless otherwise shown on the plans. Provide aggregate stockpiles that meet the definition in this Section for coarse aggregate. Do not use fine aggregate or reclaimed asphalt pavement (RAP) in PFC mixtures. Supply mechanically crushed gravel or stone aggregates that meet the definitions in Tex-100-E. The Engineer will designate the plant or the quarry as the sampling location. Samples must be from materials produced for the project. The Engineer will establish the surface aggregate classification (SAC) and perform Los Angeles abrasion, magnesium sulfate soundness, and Micro-Deval tests. Perform all other aggregate quality tests listed in Table 1. Document all test results on the mixture design report. The Engineer may perform tests on independent or split samples to verify Contractor test results. Stockpile aggregates for each source and type separately. Determine aggregate gradations for mixture design and production testing based on the washed sieve analysis given in Tex-200-F, Part II. Do not add material to an approved stockpile from sources that do not meet the aggregate quality requirements of the Department's *Bituminous Rated Source Quality Catalog* (BRSQC) unless otherwise approved.

- 1. Coarse Aggregate.** Coarse aggregate stockpiles must have no more than 20% material passing the No. 8 sieve. Provide aggregates from sources listed in the BRSQC. Provide aggregate from nonlisted sources only when tested by the Engineer and approved before use. Allow 30 calendar days for the Engineer to sample, test, and report results for nonlisted sources.

Provide coarse aggregate with at least the minimum SAC as shown on the plans. SAC requirements only apply to aggregates used on the surface of travel lanes, unless otherwise shown on the plans. The SAC for sources on the Department’s Aggregate Quality Monitoring Program (AQMP) is listed in the BRSQC.

Class B aggregate, meeting all other requirements in Table 1, may be blended with a Class A aggregate in order to meet requirements for Class A materials. When blending Class A and B aggregates to meet a Class A requirement, ensure that at least 50% by weight of the material retained on the No. 4 sieve comes from the Class A aggregate source. Blend by volume if the bulk specific gravities of the Class A and B aggregates differ by more than 0.300. When blending, do not use Class C or D aggregates.

Table 1
Coarse Aggregate Quality Requirements

Property	Test Method	Requirement
SAC	AQMP	As shown on plans
Deleterious material, %, max	Tex-217-F, Part I	1.0
Decantation, %, max	Tex-217-F, Part II	1.5
Micro-Deval abrasion, %, max	Tex-461-A	Note 1
Los Angeles abrasion, %, max	Tex-410-A	30
Magnesium sulfate soundness, 5 cycles, %, max	Tex-411-A	20
Coarse aggregate angularity, 2 crushed faces, %, min	Tex-460-A, Part I	95 ²
Flat and elongated particles @ 5:1, %, max	Tex-280-F	10

1. Not used for acceptance purposes. Used by the Engineer as an indicator of the need for further investigation.

2. Only applies to crushed gravel.

2. RAP. Do not use RAP in PFC mixtures.

- B. Baghouse Fines.** Fines collected by the baghouse or other dust collecting equipment may be reintroduced into the mixing drum.
- C. Asphalt Binder.** Furnish performance-graded (PG) asphalt binder and fibers unless the plans specify asphalt-rubber (A-R) binder. Provide asphalt binder that meets requirements of Item 300, “Asphalts, Oils, and Emulsions.”
- 1. PG Binder.** When PG binder is specified, provide an asphalt binder with a high-temperature grade of PG 76 and low-temperature grade as shown on the plans in accordance with Section 300.2.J, “Performance-Graded Binders.”

342.3 to 342.3

2. **A-R Binder** When A-R binder is specified, provide A-R binder that meets the Type I or Type II requirements of Section 300.2.I, “Asphalt-Rubber Binders,” unless otherwise shown on the plans. Use at least 15.0% by weight of Crumb Rubber Modifier (CRM) that meets the Grade B or Grade C requirements of Section 300.2.G, “Crumb Rubber Modifier,” unless otherwise shown on the plans.

3. **Tack Coat.** Unless otherwise shown on the plans or approved, furnish CSS-1H, SS-1H, or a PG binder with a minimum high-temperature grade of PG 58 for tack coat in accordance with Item 300, “Asphalts, Oils, and Emulsions.” Do not dilute emulsified asphalts at the terminal, in the field, or at any other location before use.

The Engineer will obtain at least 1 sample of the tack coat binder per project and test to verify compliance with Item 300. The Engineer will obtain the sample from the asphalt distributor immediately before use.

D. Additives. When shown on the plans, use the type and rate of additive specified. Other additives that facilitate mixing or improve the quality of the mixture may be allowed when approved.

1. **Fibers.** When PG binder is specified, provide cellulose or mineral fibers. Do not use fibers when A-R binder is specified. Submit written certification to the Engineer that the fibers proposed for use meet the requirements of DMS-9204, “Fiber Additives for Bituminous Mixtures.”

2. **Lime Mineral Filler.** When PG binder is specified, add lime as mineral filler at a rate of 1.0% by weight of the total dry aggregate. Do not add lime directly into the mixing drum of any plant where lime is removed through the exhaust stream unless the plant has a baghouse or dust collection system that reintroduces the lime back into the drum.

3. **Antistripping Agents.** If lime or a liquid antistripping agent is used, add in accordance with Item 301, “Asphalt Antistripping Agents.” When the plans require lime to be added as an antistripping agent, lime added as mineral filler will count towards the total quantity of lime specified.

342.3. Equipment. Provide required or necessary equipment in accordance with Item 320, “Equipment for Hot-Mix Asphalt Materials.” When A-R

binder is specified, equip the hot-mix plant with an in-line viscosity measuring device located between the blending unit and the mixing drum.

342.4. Construction. Produce, haul, place, and compact the specified paving mixture. When shown on the plans, schedule and participate in a prepping meeting with the Engineer as required in the Quality Control Plan (QCP).

A. Certification. Personnel certified by the Department-approved hot-mix asphalt certification program must conduct all mixture designs, sampling, and testing in accordance with Table 2. In addition to meeting the certification requirements in Table 2, all Level II certified specialists must successfully complete an approved Superpave training course. Supply the Engineer with a list of certified personnel and copies of their current certificates before beginning production and when personnel changes are made. Provide a mixture design that is developed and signed by a Level II certified specialist. Provide a Level IA certified specialist at the plant during production operations. Provide a Level IB certified specialist to conduct placement tests.

Table 2
Test Methods, Test Responsibility, and Minimum Certification Levels

1. Aggregate Testing	Test Method	Contractor	Engineer	Level
Sampling	Tex-400-A	✓	✓	IA
Dry sieve	Tex-200-F, Part I	✓	✓	IA
Washed sieve	Tex-200-F, Part II	✓	✓	IA
Deleterious material	Tex-217-F, Part I	✓	✓	II
Decantation	Tex-217-F, Part II	✓	✓	II
Los Angeles abrasion	Tex-410-A		✓	
Magnesium sulfate soundness	Tex-411-A		✓	
Micro-Deval abrasion	Tex-461-A		✓	
Coarse aggregate angularity	Tex-460-A	✓	✓	II
Flat and elongated particles	Tex-280-F	✓	✓	II
2. Mix Design & Verification	Test Method	Contractor	Engineer	Level
Design and JMF changes	Tex-204-F	✓	✓	II
Mixing	Tex-205-F	✓	✓	II
Molding (SGC)	Tex-241-F	✓	✓	IA
Laboratory-molded density	Tex-207-F	✓	✓	IA
Rice gravity	Tex-227-F	✓	✓	IA
Ignition oven calibration ¹	Tex-236-F	✓	✓	II
Drain-down	Tex-235-F	✓	✓	IA
Boil test	Tex-530-C	✓	✓	IA
Cantabro loss	Tex-245-F	✓	✓	II

Table 2 (continued)

Test Methods, Test Responsibility, and Minimum Certification Levels

3. Production Testing	Test Method	Contractor	Engineer	Level
Control charts	Tex-233-F	✓	✓	IA
Mixture sampling	Tex-222-F	✓	✓	IA
Gradation & asphalt content ¹	Tex-236-F	✓	✓	IA
Moisture content	Tex-212-F	✓	✓	IA
Micro-Deval abrasion	Tex-461-A		✓	
Drain-down	Tex-235-F	✓	✓	IA
Boil test	Tex-530-C	✓	✓	IA
Aging ratio	Tex-211-F		✓	
4. Placement Testing	Test Method	Contractor	Engineer	Level
Control charts	Tex-233-F	✓	✓	IA
Ride quality measurement	Tex-1001-S	✓	✓	IB
Thermal profile	Tex-244-F	✓	✓	IB
Tack coat adhesion	Tex-243-F		✓	
Permeability	Tex-246-F	✓	✓	IB

1. Refer to Section 342.4.E for exceptions to using ignition oven.

B. Reporting. Use Department-provided software to record and calculate all test data. The Engineer and the Contractor shall provide any available test results to the other party when requested. The Engineer and the Contractor shall immediately report to the other party any test result that requires production to be suspended or fails to meet the specification requirements. Use the approved communication method (e.g., email, diskette, hard copy) to submit test results to the Engineer.

When directed, use the procedures described in Tex-233-F to plot the results of all productions and placement testing. Update the control charts as soon as test results for each subplot become available. Make the control charts readily accessible at the field laboratory. The Engineer may suspend production for failure to update control charts.

C. QCP. Develop and follow the QCP in detail. Obtain approval from the Engineer for changes to the QCP made during the project. The Engineer may suspend operations if the Contractor fails to comply with the QCP.

When directed, submit a written QCP to the Engineer before the mandatory prepaving meeting. Receive the Engineer’s approval of the QCP before beginning production. Include the following items in the QCP.

1. **Project Personnel.** For project personnel, include:
 - a list of individuals responsible for quality control (QC) with authority to take corrective action and
 - contact information for each individual listed.
2. **Material Delivery and Storage.** For material delivery and storage, include:
 - the sequence of material processing, delivery, and minimum quantities to assure continuous plant operations;
 - aggregate stockpiling procedures to avoid contamination and segregation;
 - frequency, type, and timing of aggregate stockpile testing to assure conformance of material requirements before mixture production; and
 - procedure for monitoring the quality and variability of asphalt binder.
3. **Production.** For production, include:
 - loader operation procedures to avoid contamination in cold bins,
 - procedures for calibrating and controlling cold feeds,
 - procedures to eliminate debris or oversized material,
 - procedures for adding and verifying rates of each applicable mixture component (e.g., aggregate, asphalt binder, RAP, lime, liquid antistriper),
 - procedures for reporting job control test results, and
 - procedures to avoid segregation and drain-down in the silo.
4. **Loading and Transporting.** For loading and transporting, include:
 - type and application method for release agents and
 - truck loading procedures to avoid segregation.
5. **Placement and Compaction.** For placement and compaction, include:
 - proposed agenda for mandatory pre-paving meeting including date and location;
 - type and application method for release agents in the paver and on rollers, shovels, lutes, and other utensils
 - procedures for the transfer of mixture into the paver while avoiding segregation and preventing material spillage;
 - process to balance production, delivery, paving, and compaction to achieve continuous placement operations;

342.4 to 342.4

- paver operations (e.g., operation of wings, height of mixture in auger chamber) to avoid physical and thermal segregation and other surface irregularities; and
- procedures to construct quality longitudinal and transverse joints.

D. Mixture Design. Unless otherwise shown on the plans, use the PFC design procedure given in Tex-204-F, Part V, to design a mixture meeting the requirements listed in Tables 1, 3 and 4. Use $N_{des} = 50$ as the design number of gyrations.

The Contractor may submit a new mixture design at anytime during the project. The Engineer will approve all mixture designs before the Contractor can begin production. When shown on the plans, the Engineer will provide the mixture design.

Provide the Engineer with a mixture design report using Department-provided software. Include the following items in the report:

- the combined aggregate gradation, source, specific gravity, and percent of each material used;
- results of all applicable tests;
- the mixing and molding temperatures;
- the signature of the Level II person or persons that performed the design;
- the date the mixture design was performed; and
- a unique identification number for the mixture design.

**Table 3
Master Gradation Band (% Passing by Weight or Volume)
and Binder Content**

Sieve Size	PG 76 Mixtures	A-R Mixtures
3/4"	100.0	100.0
1/2"	80.0–100.0	95.0–100.0
3/8"	35.0–60.0	50.0–80.0
#4	1.0–20.0	0.0–8.0
#8	1.0–10.0	0.0–4.0
#200	1.0–4.0	0.0–4.0
Binder Content, %		
	5.5–7.0	8.0–10.0

Table 4
Laboratory Mixture Design Properties

Mixture Property	Test Method	Minimum	Maximum
Drain-down, %	Tex-235-F	–	0.20
Laboratory-molded density, %	Tex-207-F, Part VI	78.0 ¹	82.0
Fiber content ² , %	Calculated	0.20	0.50
Lime content ² , %	Calculated	1.0	2.0
CRM content ³ , %	Calculated	15.0	
Boil test	Tex-530-C	–	None
Cantabro loss, %	Tex-245-F	–	20.0 ¹

1. Suggested limit. Test and report for informational purposes only.

2. By weight of total mixture. Not required when using A-R.

3. By weight of asphalt. Not required when using PG 76 and fibers.

1. **Job-Mix Formula Approval.** The job-mix formula (JMF) is the combined aggregate gradation and target asphalt percentage used to establish target values for hot mix production. JMF1 is the original laboratory mixture design used to produce the trial batch. The Engineer and the Contractor will verify JMF1 based on plant-produced mixture from the trial batch unless otherwise approved. The Engineer may accept an existing mixture design previously used on a Department project and may waive the trial batch to verify JMF1.

a. Contractor's Responsibilities.

- (1) **Providing Superpave Gyratory Compactor.** Furnish a Superpave gyratory compactor (SGC), calibrated in accordance with Tex-241-F, for molding production samples. Locate the SGC at the field laboratory and make the SGC available to the Engineer for use in molding production samples.
- (2) **Gyratory Compactor Correlation Factors.** Use Tex-206-F, Part II, to perform a gyratory compactor correlation when the Engineer uses a different SGC. Apply the correlation factor to all subsequent production test results.
- (3) **Submitting JMF1.** Furnish the Engineer a mix design report (JMF1) and request approval to produce the trial batch.
- (4) **Supplying Aggregates.** Provide the Engineer with approximately 40 lb. of each aggregate stockpile unless otherwise directed.

- (5) **Supplying Asphalt.** Provide the Engineer at least 1 gal. of the asphalt material and sufficient quantities of any additives proposed for use.
- (6) **Ignition Oven Correction Factors.** Determine the aggregate and asphalt correction factors from the ignition oven using Tex-236-F. Provide the Engineer with split samples of the mixtures and blank samples used to determine the correction factors.
- (7) **Boil Test.** Perform the test and retain the tested sample from Tex-530-C. Use this sample for comparison purposes during production. The Engineer may waive the requirement for the boil test. If signs of stripping exist, add lime or liquid antistripping agent as directed.
- (8) **Trial Batch Approval.** Upon receiving conditional approval of JMF1 from the Engineer, provide a plant-produced trial batch for verification testing of JMF1 and development of JMF2.
- (9) **Trial Batch Production Equipment.** To produce the trial batch, use only equipment and materials proposed for use on the project.
- (10) **Trial Batch Quantity.** Produce enough quantity of the trial batch to ensure that the mixture is representative of JMF1.
- (11) **Number of Trial Batches.** Produce trial batches as necessary to obtain a mixture that meets the operational tolerances in Table 5.
- (12) **Trial Batch Sampling.** Obtain a representative sample of the trial batch and split it into 3 equal portions in accordance with Tex-222-F. Label these portions as “Contractor,” “Engineer,” and “Referee.” Deliver samples to the appropriate laboratory.
- (13) **Trial Batch Testing.** Test the trial batch to ensure the mixture produced using the proposed JMF1 meets the verification testing requirements for gradation, binder content, laboratory-molded density, and drain-down listed in Table 5. Provide the Engineer with a copy of the trial batch test results.
- (14) **Development of JMF2.** After the Engineer grants full approval of JMF1 based on results from the trial batch,

evaluate the trial batch test results, determine the optimum mixture proportions, and submit as JMF2.

- (15) **Mixture Production.** After receiving approval for JMF2, use JMF2 to produce Lot 1.
- (16) **Development of JMF3.** Evaluate the test results from Lot 1, determine the optimum mixture proportions, and submit as JMF3 for use in Lot 2.
- (17) **JMF Adjustments.** If necessary, adjust the JMF before beginning a new lot. The adjusted JMF must:
- be provided to the Engineer in writing before the start of a new lot,
 - be numbered in sequence to the previous JMF,
 - meet the master gradation limits shown in Table 3, and
 - be within the operational tolerances of JMF2 listed in Table 5.
- (18) **Requesting Referee Testing.** If needed, use the referee testing in accordance with Section 342.4.I.1, “Referee Testing,” to resolve testing differences with the Engineer.

b. Engineer’s Responsibilities.

- (1) **Gyratory Compactor.** For molding trial batch and production samples, the Engineer will use the Contractor-provided SGC at the Contractor’s field laboratory or provide and use a Department SGC, calibrated according to Tex-241-F, at an alternate location.
- (2) **Conditional Approval of JMF1.** Within 2 working days of receiving the mixture design report (JMF1) and all required materials, the Engineer will review the Contractor’s mixture design report and verify conformance with all aggregates, asphalt, additives, and mixture specifications. The Engineer may perform tests to verify the aggregates meet the requirements listed in Table 1. The Engineer will grant the Contractor conditional approval of JMF1 if the information provided on the paper copy of JMF1 indicates the Contractor’s mixture design meets the specifications. Full approval of JMF1 will be based on the Engineer’s test results on mixture from the trial batch.

**Table 5
Testing Frequency and Mixture Production Tolerances**

Test Description	Test Method	Minimum Contractor Testing Frequency	Minimum Engineer Testing Frequency	Operational Tolerance from JMF
Individual % retained for sieve sizes larger than #200	Tex-200-F	1 per subplot	1 per 12 sublots	±5.0 ¹
% passing the #200				±2.0 ¹
Laboratory-molded density, %	Tex-207-F, Part VI	1 per subplot	1 per lot	Table 4
Binder content, %	Tex-236-F	1 per subplot	1 per lot ²	±0.3
Drain-down, %	Tex-235-F	1 per subplot	1 per 12 sublots	Table 4
Boil test ³	Tex-530-C	1 per project	1 per project	N/A
Asphalt Binder Sampling ³	Tex-500-C	1 per subplot (sample only)	1 per project	N/A
Thermal profile	Tex-244-F	1 per subplot	Optional	N/A

1. Aggregate gradation will not exceed limits shown in Table 3.

2. May be obtained from asphalt meter readouts.

3. The Engineer may reduce or waive the sampling and testing requirements based on a satisfactory test history.

- (3) **Authorizing Trial Batch.** After conditionally approving JMF1, the Engineer will authorize the Contractor to produce a trial batch.
- (4) **Ignition Oven Correction Factor.** The Engineer will use the split samples provided by the Contractor to determine the aggregate and asphalt correction factors for the ignition oven in accordance with Tex-236-F.
- (5) **Testing the Trial Batch.** Within 1 full working day, the Engineer will sample and test the trial batch to ensure that the gradation, binder content, and laboratory molded density meet the requirements listed in Table 5.

The Engineer will have the option to perform the following tests on the trial batch:

- Tex-235-F to verify that drain-down meets the requirement shown in Table 4.
- Tex-461-A to determine the need for additional magnesium sulfate soundness testing.
- Tex-530-C to retain and use for comparison purposes during production.

- Tex-245-F to verify the Cantabro loss meets the requirement shown in Table 4.

(6) **Full Approval of JMF1.** The Engineer will grant full approval of JMF1 and authorize the Contractor to proceed with developing JMF2 if the Engineer's results for gradation, asphalt content, and laboratory-molded density confirm that the trial batch meets the requirements in Table 5.

The Engineer will notify the Contractor that an additional trial batch is required if the trial batch does not meet the requirements in Table 5.

(7) **Approval of JMF2.** The Engineer will approve JMF2 within 1 working day if it meets the master grading limits shown in Table 3 and is within the operational tolerances of JMF1 listed in Table 5.

(8) **Approval of Lot 1 Production.** The Engineer will authorize the Contractor to proceed with Lot 1 production after approving JMF2.

(9) **Approval of JMF3.** The Engineer will approve JMF3 within 1 working day if it meets the master grading limits shown in Table 3 and is within the operational tolerances of JMF2 listed in Table 5.

2. **JMF Adjustments.** Produce the mixture within the operational tolerances listed in Table 5. The Engineer may suspend production if corrective actions are not taken when operational tolerances are exceeded. With approval from the Engineer, the JMF target values may be adjusted as needed. Document any changes to the JMF with a subsequent JMF number. The Engineer may adjust the target asphalt percentage or fiber percentage within the operational tolerances of the JMF.

E. **Production Operations.** Perform a new trial batch when the plant or plant location is changed. Perform QC at the frequency and within the tolerances listed in Table 5. Take corrective action and receive approval to proceed after any production suspension for noncompliance to the specification.

At any time during production, the Engineer may require the Contractor to verify the following based on quantities used:

342.4 to 342.4

- lime content (within $\pm 0.1\%$ of JMF), when PG binder is specified;
- fiber content (within $\pm 0.03\%$ of JMF), when PG binder is specified; and
- CRM content (within $\pm 1.5\%$ of JMF), when A-R binder is specified.

When A-R binder is specified, maintain the in-line measuring device to verify the A-R binder viscosity of at least 2,500 centipoise at 350°F unless otherwise approved.

If the aggregate mineralogy is such that Tex-236-F does not yield reliable results, the Engineer may allow alternate methods for determining the asphalt content and aggregate gradation. Unless otherwise allowed, the Engineer will require the Contractor to provide evidence that results from Tex-236-F are not reliable before permitting an alternate method. If an alternate test method is allowed, use the applicable test procedure as directed.

1. **Storage and Heating of Materials.** Do not heat the asphalt binder above the temperatures specified in Item 300, “Asphalts, Oils, and Emulsions” or outside the manufacturer’s recommended values. On a daily basis, provide the Engineer with the records of asphalt binder and hot-mix asphalt discharge temperatures in accordance with Item 320, “Equipment for Hot-Mix Asphalt Materials.” Unless otherwise approved, do not store mixture for a period long enough to affect the quality of the mixture, nor in any case longer than 12 hr.
2. **Mixing and Discharge of Materials.** Notify the Engineer of the target discharge temperature and produce the mixture within 25°F of the target. Monitor the temperature of the material in the truck before shipping to ensure that it does not exceed 350°F. The Department will not pay for or allow placement of any mixture produced at more than 350°F.

Control the mixing time and temperature so that substantially all moisture is removed from the mixture before discharging from the plant. If requested, determine the moisture content by oven-drying in accordance with Tex-212-F, Part II, and verify that the mixture contains no more than 0.2% of moisture by weight. Obtain the sample immediately after discharging the mixture into the truck and perform the test promptly.

- F. **Hauling Operations.** Before use, clean all truck beds to ensure mixture is not contaminated. When a release agent is necessary to coat the truck

bed, use a release agent on the approved list maintained by the Construction Division.

G. Placement Operations. Prepare the surface by removing raised pavement markers and objectionable material such as moisture, dirt, sand, leaves, and other loose impediments from the surface before placing mixture. Remove vegetation from pavement edges. Place the mixture to meet the typical section requirements and produce a smooth, finished surface with a uniform appearance and texture. Offset longitudinal joints of successive courses of hot mix by at least 6 in. Place mixture so longitudinal joints on the surface course coincide with lane lines, or as directed. Ensure that all finished surfaces will drain properly.

1. **Weather Conditions.** Place mixture when the roadway surface temperature is 70°F or higher unless otherwise approved. Measure the roadway surface temperature with a handheld infrared thermometer. Unless otherwise shown on the plans, place mixtures only when weather conditions and moisture conditions of the roadway surface are suitable in the opinion of the Engineer.
2. **Tack Coat.** Clean the surface before placing the tack coat. Unless otherwise approved, apply tack coat uniformly at the rate directed by the Engineer. The Engineer will set the rate between 0.04 and 0.10 gal. of residual asphalt per square yard of surface area. Apply a thin, uniform tack coat to all contact surfaces of curbs, structures, and all joints. Prevent splattering of tack coat when placed adjacent to curb, gutter, and structures. Roll the tack coat with a pneumatic-tire roller when directed. The Engineer may use Tex-243-F to verify that the tack coat has adequate adhesive properties. The Engineer may suspend paving operations until there is adequate adhesion.
3. **Lay-Down Operations.** Measure the temperature of mixture delivered to the paver and take corrective action if needed to ensure the temperature does not drop below 280°F. For each subplot use a handheld infrared thermometer to obtain a thermal profile of the uncompacted mat immediately behind the paver.

Record the information on Department QC/QA forms and submit the forms to the Engineer.

- a. **Thermal Profile.** For each subplot, obtain a thermal profile using Tex-244-F. The Engineer may reduce the testing frequency based on a satisfactory test history. The Engineer may also obtain as many thermal profiles as deemed

342.4 to 342.4

necessary. If the temperature differential is greater than 25°F, the area will be deemed to have thermal segregation. Take corrective action to eliminate areas that have thermal segregation. Unless otherwise directed, suspend operations if maximum temperature differential exceeds 50°F. Resume operations when the Engineer determines that subsequent production will meet the requirements of this Item.

- b. Windrow Operations.** When hot mix is placed in windrows, operate windrow pickup equipment so that substantially all the mixture deposited on the roadbed is picked up and loaded into the paver.

- H. Compaction.** Roll the freshly placed PFC with a steel-wheeled roller, operated in static mode, to seat the mixture without excessive breakage of the aggregate and to provide a smooth surface and uniform texture. Do not use pneumatic rollers. Thoroughly moisten the roller drums with a soap-and-water solution to prevent adhesion. Unless otherwise directed, use only water or an approved release agent on rollers, tamps, and other compaction equipment.

The Engineer may use or require the Contractor to use Tex-246-F to test and verify that the compacted mixture has adequate permeability. Adjust the mixture design or construction methods if the compacted mixture does not exhibit adequate permeability.

Allow the compacted pavement to cool to 160°F or lower before opening to traffic unless otherwise directed. When directed, sprinkle the finished mat with water or limewater to expedite opening the roadway to traffic.

- I. Acceptance Plan.** Sample and test the hot mix on a lot and subplot basis. A production lot consists of 4 equal sublots. Lot 1 will be 1,000 tons. The Engineer will select subsequent lot sizes based on the anticipated daily production. The lot size will be between 1,000 and 4,000 tons. The Engineer may change the lot size before the Contractor begins any lot. If the production or placement test results are not within the acceptable tolerances listed in Table 5, suspend production until test results or other information indicate to the satisfaction of the Engineer that the next material produced or placed will meet the specified values.

- 1. Referee Testing.** The Construction Division is the referee laboratory. The Contractor may request referee testing if the differences between Contractor and Engineer test results exceed the operational tolerances shown in Table 5 and the differences cannot be resolved. Make the request within 5 working days after

receiving test results and cores from the Engineer. Referee tests will be performed only on the subplot in question and only for the particular test in question. Allow 10 working days from the time the samples are received at the referee laboratory for test results to be reported. The Department may require the Contractor to reimburse the Department for referee tests if more than 3 referee tests per project are required and the Engineer's test results are closer than the Contractor's test results to the referee test results.

- 2. Asphalt Binder Sampling.** Obtain a 1-qt. (1-gal. for A-R binder) sample of the asphalt binder for each subplot of mixture produced. Obtain the sample at approximately the same time the mixture random sample is obtained. Sample from a port located immediately upstream from the mixing drum or pug mill. Take the sample in accordance with the pipeline sampling procedure given in Tex-500-C, Part II. Label the can with the corresponding lot and subplot numbers, and deliver the sample to the Engineer.

The Engineer may also obtain independent samples. If the Engineer chooses to obtain an independent asphalt binder sample, the Engineer will split a sample of the asphalt binder with the Contractor. The Engineer will test at least 1 asphalt binder sample per project to verify compliance with Item 300, "Asphalts, Oils, and Emulsions."

- 3. Operational Tolerances.** Control the production process within the operational tolerances listed in Table 5. When production is suspended, the Engineer will allow production to resume when test results or other information indicates the next mixture produced will be within the operational tolerances.
- 4. Recovered Asphalt DSR.** The Engineer may take production samples or cores from suspect areas of the project to determine recovered asphalt properties. Asphalt binders with an aging ratio greater than 3.5 do not meet the requirements for recovered asphalt properties and may be deemed defective when tested and evaluated by the Construction Division. The aging ratio is the dynamic shear rheometer (DSR) value of the extracted binder divided by the DSR value of the original unaged binder. DSR values are obtained according to AASHTO T 315 at the specified high temperature PG of the asphalt. The Engineer may require removal and replacement of the defective material at the Contractor's expense. The asphalt binder will be recovered for testing from production samples or cores using Tex-211-F.

342.5 to 342.6

5. **Irregularities.** Immediately take appropriate corrective actions if surface irregularities, including but not limited to segregation, rutting, raveling, flushing, fat spots, mat slippage, color, texture, roller marks, tears, gouges, streaks, or uncoated aggregate particles, are detected. The Engineer may allow placement to continue for at most 1 day of production while taking appropriate action. If the problem still exists after that day, suspend paving until the problem is corrected to the satisfaction of the Engineer.

At the expense of the Contractor and to the satisfaction of the Engineer, remove and replace any mixture that does not bond to the existing pavement or that has other surface irregularities identified above.

6. **Ride Quality.** Unless otherwise shown on the plans, measure ride quality in accordance with Item 585, "Ride Quality for Pavement Surfaces."

342.5. Measurement. PFC will be measured by the ton of composite PFC. The composite PFC is defined as the asphalt, aggregate, and additives. The weights of asphalt and aggregate will be calculated based on the measured weight of PFC and the target percentage of asphalt and aggregate. Measure the weight on scales in accordance with Item 520, "Weighing and Measuring Equipment."

- A. **Asphalt.** The asphalt weight in tons will be determined from the total weight of PFC. Measured asphalt percentage will be obtained using Tex-236-F or asphalt flow meter readings, as determined by the Engineer.
 1. **Target Percentage.** The JMF target asphalt percentage will be used to calculate the weight of asphalt binder unless the measured asphalt binder percentage is more than 0.3 percentage points below the JMF target asphalt percentage. Volumetric meter readings will be adjusted to 140°F and converted to weight.
 2. **Measured Percentage.** The measured asphalt percentage will be used for payment for that lot's production when the measured percentage is more than 0.3 percentage points below the JMF target asphalt percentage.
- B. **Aggregate.** The aggregate weight in tons will be determined from the total weight of PFC less the weight of the asphalt.

342.6. Payment. The work performed and materials furnished in accordance with this Item and measured as provided under "Measurement"

will be paid for at the unit price bid for “PFC (Asphalt)” of the binder specified and for “PFC (Aggregate)” of the grade and surface aggregate classification specified. These prices are full compensation for surface preparation, materials including tack coat, placement, equipment, labor, tools, and incidentals.

Trial batches will not be paid for unless they are included in pavement work approved by the Department.

Pay adjustment for ride quality will be determined in accordance with Item 585, “Ride Quality for Pavement Surfaces.”

ITEM 344

PERFORMANCE-DESIGNED MIXTURES

344.1. Description. Construct a pavement layer composed of a compacted performance-designed mixture of aggregate and asphalt binder mixed hot in a mixing plant. Performance-designed mixtures are defined as either Superpave (SP) or coarse-matrix high-binder (CMHB) mixtures.

344.2. Materials. Furnish uncontaminated materials of uniform quality that meet the requirements of the plans and specifications.

Notify the Engineer of all material sources. Notify the Engineer before changing any material source or formulation. When the Contractor makes a source or formulation change, the Engineer will verify that the specification requirements are met and may require a new laboratory mixture design, trial batch, or both. The Engineer may sample and test project materials at any time during the project to verify specification compliance.

A. Aggregate. Furnish aggregates from sources that conform to the requirements shown in Table 1, and as specified in this Section, unless otherwise shown on the plans. Provide aggregate stockpiles that meet the definition in this Section for either a coarse aggregate or fine aggregate. When reclaimed asphalt pavement (RAP) is allowed by plan note, provide RAP stockpiles in accordance with this Section. Aggregate from RAP is not required to meet Table 1 requirements unless otherwise shown on the plans. Supply mechanically crushed gravel or stone aggregates that meet the definitions in Tex-100-E. The Engineer will designate the plant or the quarry as the sampling location. Samples must be from materials produced for the project. The Engineer will establish the surface aggregate classification (SAC) and perform Los Angeles abrasion, magnesium sulfate soundness, and Micro-Deval tests. Perform all other aggregate quality tests listed in Table 1.

Document all test results on the mixture design report. The Engineer may perform tests on independent or split samples to verify Contractor test results. Stockpile aggregates for each source and type separately. Determine aggregate gradations for mixture design and production testing based on the washed sieve analysis given in Tex-200-F, Part II. Do not add material to an approved stockpile from sources that do not meet the aggregate quality requirements of the Department's *Bituminous Rated Source Quality Catalog* (BRSQC) unless otherwise approved.

1. **Coarse Aggregate.** Coarse aggregate stockpiles must have no more than 20% material passing the No. 8 sieve. Provide aggregates from sources listed in the BRSQC. Provide aggregate from nonlisted sources only when tested by the Engineer and approved before use. Allow 30 calendar days for the Engineer to sample, test, and report results for nonlisted sources.

Provide coarse aggregate with at least the minimum SAC shown on the plans. SAC requirements apply only to aggregates used on the surface of travel lanes, unless otherwise shown on the plans. The SAC for sources on the Department's Aggregate Quality Monitoring Program (AQMP) is listed in the BRSQC.

Class B aggregate meeting all other requirements in Table 1 may be blended with a Class A aggregate in order to meet requirements for Class A materials. When blending Class A and B aggregates to meet a Class A requirement, ensure that at least 50% by weight of the material retained on the No. 4 sieve comes from the Class A aggregate source. Blend by volume if the bulk specific gravities of the Class A and B aggregates differ by more than 0.300. When blending, do not use Class C or D aggregates. For blending purposes, coarse aggregate from RAP will be considered as Class B aggregate.

2. **RAP.** RAP is salvaged, milled, pulverized, broken, or crushed asphalt pavement. Crush or break RAP so that 100% of the particles pass the 2-in. sieve.

RAP from either Contractor- or Department-owned sources, including RAP generated during the project, is permitted only when shown on the plans. Department-owned RAP, if allowed for use, will be available at the location shown on the plans. When RAP is used, determine asphalt content and gradation for mixture design purposes. Perform other tests on RAP when shown on the

plans. When RAP is allowed by plan note, use no more than 20% RAP unless otherwise shown on the plans.

Do not use RAP contaminated with dirt or other objectionable materials. Do not use the RAP if the decantation value exceeds 5% and the plasticity index is greater than 8. Test the stockpiled RAP for decantation in accordance with the laboratory method given in Tex-406-A, Part I. Determine the plasticity index using Tex-106-E if the decantation value exceeds 5%. The decantation and plasticity index requirements do not apply to RAP samples with asphalt removed by extraction.

Do not intermingle Contractor-owned RAP stockpiles with Department-owned RAP stockpiles. Remove unused Contractor-owned RAP material from the project site upon completion of the project. Return unused Department-owned RAP to the designated stockpile location.

3. **Fine Aggregate.** Fine aggregates consist of manufactured sands, screenings, and field sands. Fine aggregate stockpiles must meet the gradation requirements in Table 2. Supply fine aggregates that are free from organic impurities. The Engineer may test the fine aggregate in accordance with Tex-408-A to verify the material is free from organic impurities. At most 15% of the total aggregate may be field sand or other uncrushed fine aggregate. With the exception of field sand and fine aggregates used in CMHB mixtures, use fine aggregate from coarse aggregate sources that meet the requirements shown in Table 1, unless otherwise approved.

If 10% or more of the stockpile is retained on the No. 4 sieve, test the stockpile and verify that it meets the requirements in Table 1 for coarse aggregate angularity (Tex-460-A) and flat and elongated particles (Tex-280-F).

**Table 1
Aggregate Quality Requirements**

Property	Test Method	Requirement
Coarse Aggregate		
SAC	AQMP	As shown on plans
Deleterious material, %, max	Tex-217-F, Part I	1.0
Decantation, %, max	Tex-217-F, Part II	1.5
Micro-Deval abrasion, %, max	Tex-461-A	Note 1
Los Angeles abrasion, %, max	Tex-410-A	35
Magnesium sulfate soundness, 5 cycles, %, max	Tex-411-A	25
Coarse aggregate angularity, 2 crushed faces, %, min	Tex 460-A, Part I	95 ²
Flat and elongated particles @ 5:1, %, max	Tex-280-F	10
Fine Aggregate		
Linear shrinkage, %, max	Tex-107-E	3
Combined Aggregate³		
Sand equivalent, %, min	Tex-203-F	45

1. Not used for acceptance purposes. Used by the Engineer as an indicator of the need for further investigation.

2. Only applies to crushed gravel.

3. Aggregates, without mineral filler, RAP, or additives, combined as used in the job-mix formula (JMF).

**Table 2
Gradation Requirements for Fine Aggregate**

Sieve Size	% Passing by Weight or Volume
3/8"	100
#8	70-100
#200	0-30

B. Mineral Filler. Mineral filler consists of finely divided mineral matter such as agricultural lime, crusher fines, hydrated lime, cement, or fly ash. Mineral filler is allowed unless otherwise shown on the plans. Do not use more than 2% hydrated lime or cement, unless otherwise shown on the plans. The plans may require or disallow specific mineral fillers. When used, provide mineral filler that:

- is sufficiently dry, free-flowing, and free from clumps and foreign matter;
- does not exceed 3% linear shrinkage when tested in accordance with Tex-107-E; and
- meets the gradation requirements in Table 3.

Table 3
Gradation Requirements for Mineral Filler

Sieve Size	% Passing by Weight or Volume
#8	100
#200	55–100

- C. Baghouse Fines.** Fines collected by the baghouse or other dust-collecting equipment may be reintroduced into the mixing drum.
- D. Asphalt Binder.** Furnish the type and grade of performance-graded (PG) asphalt binder specified on the plans, in accordance with Section 300.2.J, “Performance-Graded Binders.”
- E. Tack Coat.** Unless otherwise shown on the plans or approved, furnish CSS-1H, SS-1H, or a PG binder with a minimum high-temperature grade of PG 58 for tack coat binder in accordance with Item 300, “Asphalts, Oils, and Emulsions.” Do not dilute emulsified asphalts at the terminal, in the field, or at any other location before use.

The Engineer will obtain at least 1 sample of the tack coat binder per project and test it to verify compliance with Item 300. The Engineer will obtain the sample from the asphalt distributor immediately before use.

- F. Additives.** When shown on the plans, use the type and rate of additive specified. Other additives that facilitate mixing or improve the quality of the mixture may be allowed when approved.

If lime or a liquid antistripping agent is used, add in accordance with Item 301, “Asphalt Antistripping Agents.” Do not add lime directly into the mixing drum of any plant where lime is removed through the exhaust stream, unless the plant has a baghouse or dust collection system that reintroduces the lime back into the drum.

344.3. Equipment. Provide required or necessary equipment in accordance with Item 320, “Equipment for Hot-Mix Asphalt Materials.”

344.4. Construction. Produce, haul, place, and compact the specified paving mixture. Schedule and participate in a prepaving meeting with the Engineer as required in the Quality Control Plan (QCP).

- A. Certification.** Personnel certified by the Department-approved hot-mix asphalt certification program must conduct all mixture designs, sampling, and testing in accordance with Table 4. In addition to meeting the certification requirements in Table 4, all Level II certified specialists must successfully complete an approved SP training course.

344.4 to 344.4

Supply the Engineer with a list of certified personnel and copies of their current certificates before beginning production and when personnel changes are made. Provide a mixture design that is developed and signed by a Level II certified specialist. Provide a Level IA certified specialist at the plant during production operations. Provide a Level IB certified specialist to conduct placement tests.

**Table 4
Test Methods, Test Responsibility, and Minimum Certification Levels**

1. Aggregate Testing	Test Method	Contractor	Engineer	Level
Sampling	Tex-400-A	✓	✓	IA
Dry sieve	Tex-200-F, Part I	✓	✓	IA
Washed sieve	Tex-200-F, Part II	✓	✓	IA
Deleterious material	Tex-217-F, Part I	✓	✓	II
Decantation	Tex-217-F, Part II	✓	✓	II
Los Angeles abrasion	Tex-410-A		✓	
Magnesium sulfate soundness	Tex-411-A		✓	
Micro-Deval abrasion	Tex-461-A		✓	
Coarse aggregate angularity	Tex-460-A	✓	✓	II
Flat and elongated particles	Tex-280-F	✓	✓	II
Linear shrinkage	Tex-107-E	✓	✓	II
Sand equivalent	Tex-203-F	✓	✓	II
Organic impurities	Tex-408-A	✓	✓	II
2. Mix Design & Verification	Test Method	Contractor	Engineer	Level
Design and JMF changes	Tex-204-F	✓	✓	II
Mixing	Tex-205-F	✓	✓	II
Molding (SGC)	Tex-241-F	✓	✓	IA
Laboratory-molded density	Tex-207-F	✓	✓	IA
VMA	Tex-207-F	✓	✓	II
Rice gravity	Tex-227-F	✓	✓	IA
Ignition oven calibration ¹	Tex-236-F	✓	✓	II
Indirect tensile strength	Tex-226-F	✓	✓	II
Hamburg Wheel test	Tex-242-F	✓	✓	II
Boil test	Tex-530-C	✓	✓	IA

Table 4 (continued)
Test Methods, Test Responsibility, and Minimum Certification Levels

3. Production Testing	Test Method	Contractor	Engineer	Level
Random sampling	Tex-225-F		✓	IA
Mixture sampling	Tex-222-F	✓	✓	IA
Molding (SGC)	Tex-241-F	✓	✓	IA
Laboratory-molded density	Tex-207-F	✓	✓	IA
VMA (calculation only)	Tex-207-F	✓	✓	IA
Rice gravity	Tex-227-F	✓	✓	IA
Gradation & asphalt content ¹	Tex-236-F	✓	✓	IA
Control charts	Tex-233-F	✓	✓	IA
Moisture content	Tex-212-F	✓	✓	IA
Hamburg Wheel test	Tex-242-F	✓	✓	II
Micro-Deval abrasion	Tex-461-A		✓	
Boil test	Tex-530-C	✓	✓	IA
Aging ratio	Tex-211-F		✓	
4. Placement Testing	Test Method	Contractor	Engineer	Level
Random sampling	Tex-225-F		✓	IA
Establish rolling pattern	Tex-207-F	✓		IB
In-Place air voids	Tex-207-F	✓	✓	IA
Control charts	Tex-233-F	✓	✓	IA
Ride quality measurement	Tex-1001-S	✓	✓	IB
Segregation (density profile)	Tex-207-F, Part V	✓	✓	IB
Longitudinal Joint Density	Tex-207-F, Part VII	✓	✓	IB
Thermal profile	Tex-244-F	✓	✓	IB
Tack coat adhesion	Tex-243-F		✓	IB

1. Refer to Section 344.4.I.2.c for exceptions to using an ignition oven.

B. Reporting. Use Department-provided software to record and calculate all test data. The Engineer and the Contractor shall provide any available test results to the other party when requested. The maximum allowable time for the Contractor and Engineer to exchange test data is as given in Table 5 unless otherwise approved. The Engineer and the Contractor shall immediately report to the other party any test result that requires production to be suspended, a payment penalty, or fails to meet the specification requirements. Use the approved communication method (e.g., email, diskette, hard copy) to submit test results to the Engineer.

The Engineer will use the Department-provided software to calculate all pay adjustment factors for the lot. Sublot samples may be discarded after the Engineer and Contractor sign off on the pay adjustment summary documentation for the lot.

344.4 to 344.4

Use the procedures described in Tex-233-F to plot the results of all quality control (QC) and quality assurance (QA) testing. Update the control charts as soon as test results for each subplot become available. Make the control charts readily accessible at the field laboratory. The Engineer may suspend production for failure to update control charts.

Table 5
Reporting Schedule

Description	Reported by	Reported To	To Be Reported Within
Production Quality Control			
Gradation ¹ Asphalt content ¹ Laboratory-molded density ² Moisture content ³ Boil test ³	Contractor	Engineer	1 working day of completion of the subplot
Production Quality Assurance			
Gradation ³ Asphalt content ³ Laboratory-molded density ¹ Hamburg Wheel test ² Boil test ³ Binder tests ²	Engineer	Contractor	1 working day of completion of the subplot
Placement Quality Control			
In-Place air voids ² Segregation ¹ Longitudinal joint density ¹ Thermal profile ¹	Contractor	Engineer	1 hr. of performing the test for segregation, longitudinal joint density, and thermal profile
Placement Quality Assurance			
In-Place Air Voids ¹ Segregation ² Longitudinal joint density ² Thermal profile ² Aging ratio ²	Engineer	Contractor	1 working day of receipt of the trimmed cores for in-place air voids ⁴
Pay Adjustment Summary	Engineer	Contractor	2 working days of performing all required tests and receiving Contractor test data

1. These tests are required on every subplot.
2. Optional test. To be reported as soon as results become available.
3. To be performed at the frequency shown in Table 12.
4. Additional time is allowed if cores cannot be dried to constant weight within 1 day.

C. QCP. Develop and follow the QCP in detail. Obtain approval from the Engineer for changes to the QCP made during the project. The Engineer may suspend operations if the Contractor fails to comply with the QCP.

Submit a written QCP to the Engineer before the mandatory prepaving meeting. Receive the Engineer's approval of the QCP before beginning production. Include the following items in the QCP.

1. **Project Personnel.** For project personnel, include:
 - a list of individuals responsible for QC with authority to take corrective action and
 - contact information for each individual listed.
2. **Material Delivery and Storage.** For material delivery and storage, include:
 - the sequence of material processing, delivery, and minimum quantities to assure continuous plant operations;
 - aggregate stockpiling procedures to avoid contamination and segregation;
 - frequency, type, and timing of aggregate stockpile testing to assure conformance of material requirements before mixture production; and
 - procedure for monitoring the quality and variability of asphalt binder.
3. **Production.** For production, include:
 - loader operation procedures to avoid contamination in cold bins,
 - procedures for calibrating and controlling cold feeds,
 - procedures to eliminate debris or oversized material,
 - procedures for adding and verifying rates of each applicable mixture component (e.g., aggregate, asphalt binder, RAP, lime, liquid antistrip),
 - procedures for reporting job control test results, and
 - procedures to avoid segregation and drain-down in the silo.
4. **Loading and Transporting.** For loading and transporting, include:
 - type and application method for release agents and
 - truck loading procedures to avoid segregation.
5. **Placement and Compaction.** For placement and compaction, include:
 - proposed agenda for mandatory prepaving meeting including date and location;
 - type and application method for release agents in the paver and on rollers, shovels, lutes, and other utensils;
 - procedures for the transfer of mixture into the paver while avoiding segregation and preventing material spillage;

344.4 to 344.4

- process to balance production, delivery, paving, and compaction to achieve continuous placement operations;
- paver operations (e.g., operation of wings, height of mixture in auger chamber) to avoid physical and thermal segregation and other surface irregularities; and
- procedures to construct quality longitudinal and transverse joints.

D. Mixture Design.

1. **Design Requirements.** Unless otherwise shown on the plans, use the Superpave design procedure given in Tex-204-F, Part IV, to design a mixture meeting the requirements listed in Tables 1, 2, 3, 6, 7, and 8. Use an approved laboratory to perform the Hamburg Wheel test and provide results with the mixture design or provide the laboratory mixture and request that the Department perform the Hamburg Wheel test. The Construction Division maintains a list of approved laboratories. The Engineer will be allowed 10 working days to provide the Contractor with Hamburg Wheel test results on the laboratory mixture design.

The Contractor may submit a new mixture design at any time during the project. The Engineer will approve all mixture designs before the Contractor can begin production. When shown on the plans, the Engineer will provide the mixture design.

Design the mixture at the number of gyrations (Ndes) shown on the plans. Unless otherwise shown on the plans, the aggregate gradation may pass above, below, or through the reference zone shown in Table 7. When shown on the plans, design a mixture with a gradation that has stone-on-stone contact and passes below the reference zone shown in Table 7. Verify stone-on-stone contact using the method given in the Superpave design procedure in Tex-204-F, Part IV.

For mixture designated on the plans as a “rich bottom layer” (RBL), design for a target laboratory molded density of 98.0% at $N_{des} = 50$. Design the RBL with a gradation that does not pass below the reference zone shown in Table 7. RBL will only be designated as the bottom lift on perpetual pavement designs.

Provide the Engineer with a mixture design report using Department-provided software. Include the following items in the report:

- the combined aggregate gradation, source, specific gravity, and percent of each material used;

- results of all applicable tests;
- the mixing and molding temperatures;
- the signature of the Level II person or persons that performed the design;
- the date the mixture design was performed; and
- a unique identification number for the mixture design.

Table 6
Master Gradation Bands (% Passing by Weight or Volume)
and Volumetric Properties

Sieve Size	SP-A Base	SP-B Intermediate	SP-C Surface	SP-D Fine Mixture	CMHB-C Coarse Surface	CMHB-F Fine Surface
2"	100.0	–	–	–	–	–
1-1/2"	98.0–100.0	100.0	–	–	–	–
1"	90.0–100.0	98.0–100.0	100.0	–	100.0	–
3/4"	Note 1	90.0–100.0	98.0–100.0	100.0	98.0–100.0	100.0
1/2"	–	Note 1	90.0–100.0	98.0–100.0	72.0–85.0	98.0–100.0
3/8"	–	–	Note 1	90.0–100.0	50.0–70.0	85.0–100.0
#4	–	–	–	Note 1	30.0–45.0	40.0–60.0
#8	19.0–45.0	23.0–49.0	28.0–58.0	32.0–67.0	17.0–27.0	17.0–27.0
#16	1.0–45.0	2.0–49.0	2.0–58.0	2.0–67.0	5.0–27.0	5.0–27.0
#30	1.0–45.0	2.0–49.0	2.0–58.0	2.0–67.0	5.0–27.0	5.0–27.0
#50	1.0–45.0	2.0–49.0	2.0–58.0	2.0–67.0	5.0–27.0	5.0–27.0
#200	1.0–7.0	2.0–8.0	2.0–10.0	2.0–10.0	5.0–9.0	5.0–9.0
Design VMA², % Minimum						
	13.0	14.0	15.0	16.0	14.0	15.0
Plant-Produced VMA, % Minimum						
	12.5	13.5	14.5	15.5	13.0	14.0
Design VFA³, %						
	65–75	65–75	73–76	73–76	–	–

1. Must retain at least 10% cumulative.
2. Voids in mineral aggregates.
3. Voids filled with asphalt.

Table 7
Reference Zones (% Passing by Weight or Volume)

Sieve Size	SP-A Base	SP-B Intermediate	SP-C Surface	SP-D Fine Mixture	CMHB-C Coarse Surface	CMHB-F Fine Surface
2"	–	–	–	–	N/A	N/A
1-1/2"	–	–	–	–		
1"	–	–	–	–		
3/4"	–	–	–	–		
1/2"	–	–	–	–		
3/8"	–	–	–	–		
#4	39.5–39.5	–	–	–		
#8	26.8–30.8	34.6–34.6	39.1–39.1	47.2–47.2		
#16	18.1–24.1	22.3–28.3	25.6–31.6	31.6–37.6		
#30	13.6–17.5	16.7–20.7	19.1–23.1	23.5–27.5		
#50	11.4–11.4	13.7–13.7	15.5–15.5	18.7–18.7		
#200	–	–	–	–		

Table 8
Laboratory Mixture Design Properties

Mixture Property	Test Method	Requirement
Target Laboratory-Molded Density, %	Tex-207-F	96.0
Tensile Strength (dry), psi (molded to 93% ±1% density)	Tex-226-F	85–200 ¹
Dust/Asphalt Ratio ²		0.6–1.6
Boil Test ³	Tex-530-C	–
Hamburg Wheel Test Requirements		
High-Temperature Binder Grade	Test Method	Minimum # of Passes @ 0.5" Rut Depth, Tested @122°F ⁴
PG 64 or lower	Tex-242-F	10,000
PG 70		15,000
PG 76 or higher		20,000

1. May exceed 200 psi when approved and may be waived when approved.

2. Defined as % passing #200 sieve divided by asphalt content. Not required for CMHB mixtures.

3. Used to establish baseline for comparison to production results. May be waived when approved.

4. May be decreased or waived when shown on the plans. Test not required for RBL.

- 2. Job-Mix Formula Approval.** The job-mix formula (JMF) is the combined aggregate gradation and target asphalt percentage used to establish target values for hot mix production. JMF1 is the original laboratory mixture design used to produce the trial batch. The Engineer and the Contractor will verify JMF1 based on plant-produced mixture from the trial batch unless otherwise approved. The Engineer may accept an existing mixture design previously used on a Department project and may waive the trial batch to verify JMF1.

a. **Contractor's Responsibilities.**

- (1) **Providing Superpave Gyratory Compactor.** Furnish a Superpave gyratory compactor (SGC), calibrated in accordance with Tex-241-F, for molding production samples. Locate the SGC at the Engineer's field laboratory and make the SGC available to the Engineer for use in molding production samples.
- (2) **Gyratory Compactor Correlation Factors.** Use Tex-206-F, Part II, to perform a gyratory compactor correlation when the Engineer uses a different SGC. Apply the correlation factor to all subsequent production test results.
- (3) **Submitting JMF1.** Furnish the Engineer a mix design report (JMF1) and request approval to produce the trial batch. If opting to have the Department perform the Hamburg Wheel test on the laboratory mixture, provide the Engineer with approximately 10,000 g of the design mixture and request that the Department perform the Hamburg Wheel test.
- (4) **Supplying Aggregates.** Provide the Engineer with approximately 40 lb. of each aggregate stockpile unless otherwise directed.
- (5) **Supplying Asphalt.** Provide the Engineer at least 1 gal. of the asphalt material and sufficient quantities of any additives proposed for use.
- (6) **Ignition Oven Correction Factors.** Determine the aggregate and asphalt correction factors from the ignition oven using Tex-236-F. Provide the Engineer with split samples of the mixtures and blank samples used to determine the correction factors.
- (7) **Boil Test.** Perform the test and retain the tested sample from Tex-530-C. Use this sample for comparison purposes during production. The Engineer may waive the requirement for the boil test.
- (8) **Trial Batch Approval.** Upon receiving conditional approval of JMF1 from the Engineer, provide a plant-produced trial batch for verification testing of JMF1 and development of JMF2.

- (9) **Trial Batch Production Equipment.** To produce the trial batch, use only equipment and materials proposed for use on the project.
- (10) **Trial Batch Quantity.** Produce enough quantity of the trial batch to ensure that the mixture is representative of JMF1.
- (11) **Number of Trial Batches.** Produce trial batches as necessary to obtain a mixture that meets the requirements in Table 9.
- (12) **Trial Batch Sampling.** Obtain a representative sample of the trial batch and split it into 3 equal portions in accordance with Tex-222-F. Label these portions as “Contractor,” “Engineer,” and “Referee.” Deliver samples to the appropriate laboratory as directed.
- (13) **Trial Batch Testing.** Test the trial batch to ensure the mixture produced using the proposed JMF1 meets the verification testing requirements for gradation, asphalt content, laboratory-molded density, and VMA listed in Table 9 and is in compliance with the Hamburg Wheel test requirement in Table 8. Use an approved laboratory to perform the Hamburg Wheel test on the trial batch mixture or request that the Department perform the Hamburg Wheel test. The Engineer will be allowed 10 working days to provide the Contractor with Hamburg Wheel test results on the trial batch. Provide the Engineer with a copy of the trial batch test results.
- (14) **Development of JMF2.** After the Engineer grants full approval of JMF1 based on results from the trial batch, evaluate the trial batch test results, determine the optimum mixture proportions, and submit as JMF2.
- (15) **Mixture Production.** After receiving approval for JMF2 and receiving a passing result from the Department’s or a Department-approved laboratory’s Hamburg Wheel test on the trial batch, use JMF2 to produce Lot 1 as described in Section 344.4.I.3.a.(1), “Lot 1 Placement.” As an option, once JMF2 is approved, proceed to Lot 1 production at the Contractor’s risk without receiving the results from the Department’s Hamburg Wheel test on the trial batch.

If electing to proceed without Hamburg Wheel test results from the trial batch, notify the Engineer. Note that the Engineer may require up to the entire subplot of any mixture failing the Hamburg Wheel test be removed and replaced at the Contractor's expense.

- (16) **Development of JMF3.** Evaluate the test results from Lot 1, determine the optimum mixture proportions, and submit as JMF3 for use in Lot 2.
- (17) **JMF Adjustments.** If necessary, adjust the JMF before beginning a new lot. The adjusted JMF must:
- be provided to the Engineer in writing before the start of a new lot,
 - be numbered in sequence to the previous JMF,
 - meet the master gradation limits shown in Table 6, and
 - be within the operational tolerances of JMF2 listed in Table 9.
- (18) **Requesting Referee Testing.** If needed, use referee testing in accordance with Section 344.4.I.1, "Referee Testing," to resolve testing differences with the Engineer.

Table 9
Operational Tolerances

Description	Test Method	Allowable Difference from Current JMF Target	Allowable Difference between Contractor and Engineer ¹
Individual % retained for #8 sieve and larger	Tex-200-F or Tex-236-F	±5.0 ²	±5.0
Individual % retained for sieves smaller than #8 and larger than #200		±3.0 ²	±3.0
% passing the #200 sieve		±2.0 ²	±1.6
Asphalt content, %	Tex-236-F	±0.3 ³	±0.3
Laboratory-molded density, %	Tex-207-F	±1.0	±0.5
In-Place air voids, %		N/A	±1.0
Laboratory-molded bulk specific gravity		N/A	±0.020
VMA, % min		Note 4	N/A
Theoretical maximum specific (Rice) gravity	Tex-227-F	N/A	± 0.020

1. Contractor may request referee testing only when values exceed these tolerances.
2. When within these tolerances, mixture production gradations may fall outside the master grading limits; however, the % passing the #200 will be considered out of tolerance when outside the master grading limits.
3. Tolerance between JMF1 and JMF2 may exceed ±0.3%.
4. Test and verify that Table 6 requirements are met.

b. Engineer's Responsibilities.

- (1) **Gyratory Compactor.** The Engineer will use a Department SGC, calibrated according to Tex-241-F, to mold samples for laboratory mixture design verification. For molding trial batch and production specimens, the Engineer will use the Contractor-provided SGC at the field laboratory or provide and use a Department SGC at an alternate location. The Engineer will make the Contractor-provided SGC in the Department field laboratory available to the Contractor for molding verification samples.
- (2) **Conditional Approval of JMF1.** Within 2 working days of receiving the mixture design report (JMF1) and all required materials and Contractor-provided Hamburg Wheel test results, the Engineer will review the Contractor's mix design report and verify conformance with all aggregates, asphalt, additives, and mixture specifications. The Engineer may perform tests to verify the aggregates meet the requirements listed in Table 1. The Engineer will grant the Contractor conditional

approval of JMF1 if the information provided on the paper copy of JMF1 indicates the Contractor's mixture design meets the specifications. When the Contractor does not provide Hamburg Wheel test results with laboratory mixture design, a total of 10 working days is allowed for conditional approval of JMF1. Full approval of JMF1 will be based on the Engineer's test results on mixture from the trial batch.

- (3) **Hamburg Wheel Testing of JMF1.** If the Contractor requests the option to have the Department perform the Hamburg Wheel test on the laboratory mixture, the Engineer will mold samples in accordance with Tex-242-F to verify compliance with the Hamburg Wheel test requirement in Table 8.
- (4) **Authorizing Trial Batch.** After conditionally approving JMF1, which will include either Contractor- or Department-supplied Hamburg Wheel test results, the Engineer will authorize the Contractor to produce a trial batch.
- (5) **Ignition Oven Correction Factors.** The Engineer will use the split samples provided by the Contractor to determine the aggregate and asphalt correction factors for the ignition oven in accordance with Tex-236-F.
- (6) **Testing the Trial Batch.** Within 1 full working day, the Engineer will sample and test the trial batch to ensure that the gradation, asphalt content, laboratory-molded density, and VMA meet the requirements listed in Table 9. If the Contractor requests the option to have the Department perform the Hamburg Wheel test on the trial batch mixture, the Engineer will mold samples in accordance with Tex-242-F to verify compliance with the Hamburg Wheel test requirement in Table 8.

The Engineer will have the option to perform the following tests on the trial batch:

- Tex-226-F to verify that the indirect tensile strength meets the requirement shown in Table 7.
- Tex-461-A to determine the need for additional magnesium sulfate soundness testing.
- Tex-530-C to retain and use for comparison purposes during production.

- (7) **Full Approval of JMF1.** The Engineer will grant full approval of JMF1 and authorize the Contractor to proceed with developing JMF2 if the Engineer's results for gradation, asphalt content, laboratory-molded density, and VMA confirm that the trial batch meets the requirements in Table 9.

The Engineer will notify the Contractor that an additional trial batch is required if the trial batch does not meet the requirements in Table 9.

- (8) **Approval of JMF2.** The Engineer will approve JMF2 within 1 working day if it meets the master grading limits shown in Table 6 and is within the operational tolerances of JMF1 listed in Table 9.
- (9) **Approval of Lot 1 Production.** The Engineer will authorize the Contractor to proceed with Lot 1 production as soon as a passing result is achieved from the Department's or an approved laboratory's Hamburg Wheel test on the trial batch. As an option, the Contractor may at their own risk, proceed with Lot 1 production without the results from the Hamburg Wheel test on the trial batch.

If the Department's or approved laboratory's sample from the trial batch fails the Hamburg Wheel test, the Engineer will suspend production until further Hamburg Wheel tests meet the specified values. The Engineer may require up to the entire subplot of any mixture failing the Hamburg Wheel test to be removed and replaced at the Contractor's expense.

- (10) **Approval of JMF3.** The Engineer will approve JMF3 within 1 working day if it meets the master grading limits shown in Table 6 and is within the operational tolerances of JMF2 listed in Table 9.

E. Production Operations. Perform a new trial batch when the plant or plant location is changed. Take corrective action and receive approval to proceed after any production suspension for noncompliance to the specification.

- 1. Storage and Heating of Materials.** Do not heat the asphalt binder above the temperatures specified in Item 300, "Asphalts, Oils, and Emulsions," or outside the manufacturer's recommended values.

On a daily basis, provide the Engineer with the records of asphalt binder and hot mix asphalt discharge temperatures in accordance with Item 320, "Equipment for Hot-Mix Asphalt Materials."

Unless otherwise approved, do not store mixture for a period long enough to affect the quality of the mixture, nor in any case longer than 12 hr.

2. **Mixing and Discharge of Materials.** Notify the Engineer of the target discharge temperature and produce the mixture within 25°F of the target. Monitor the temperature of the material in the truck before shipping to ensure that it does not exceed 350°F. The Department will not pay for or allow placement of any mixture produced at more than 350°F.

Control the mixing time and temperature so that substantially all moisture is removed from the mixture before discharging from the plant. If requested, determine the moisture content by oven-drying in accordance with Tex-212-F, Part II, and verify that the mixture contains no more than 0.2% of moisture by weight. Obtain the sample immediately after discharging the mixture into the truck, and perform the test promptly.

- F. **Hauling Operations.** Before use, clean all truck beds to ensure mixture is not contaminated. When a release agent is necessary, use a release agent on the approved list maintained by the Construction Division to coat the inside bed of the truck.
- G. **Placement Operations.** Prepare the surface by removing raised pavement markers and objectionable material such as moisture, dirt, sand, leaves, and other loose impediments from the surface before placing mixture. Remove vegetation from pavement edges. Place the mixture to meet the typical section requirements and produce a smooth, finished surface with a uniform appearance and texture. Offset longitudinal joints of successive courses of hot mix by at least 6 in. Place mixture so longitudinal joints on the surface course coincide with lane lines, or as directed. Ensure that all finished surfaces will drain properly. Place mixture within the compacted lift thickness shown in Table 10 unless otherwise shown on the plans or allowed.

Table 10
Compacted Lift Thickness and Required Core Height

Mixture Type	Compacted Lift Thickness		Minimum Untrimmed Core Height (in.) Eligible for Testing
	Minimum (in.)	Maximum (in.)	
SP-A	3.00	5.0	2.50
SP-B	2.25	4.0	2.00
SP-C	1.50	3.0	1.25
SP-D	1.25	2.0	1.25
CMHB-C	2.00	4.0	1.75
CMHB-F	1.50	3.0	1.25

1. **Weather Conditions.** Place mixture when the roadway surface temperature is 60°F or higher unless otherwise approved. Measure the roadway surface temperature with a handheld infrared thermometer. Unless otherwise shown on the plans, place mixtures only when weather conditions and moisture conditions of the roadway surface are suitable in the opinion of the Engineer.
2. **Tack Coat.** Clean the surface before placing the tack coat. Unless otherwise approved, apply tack coat uniformly at the rate directed by the Engineer. The Engineer will set the rate between 0.04 and 0.10 gal. of residual asphalt per square yard of surface area. Apply a thin, uniform tack coat to all contact surfaces of curbs, structures, and all joints. Prevent splattering of tack coat when placed adjacent to curb, gutter, and structures. Roll the tack coat with a pneumatic-tire roller when directed. The Engineer may use Tex-243-F to verify that the tack coat has adequate adhesive properties. The Engineer may suspend paving operations until there is adequate adhesion.
3. **Lay-Down Operations.** Use the guidelines in Table 11 to establish the temperature of mixture delivered to the paver. Record the information on Department QC/QA forms and submit the forms to the Engineer.
 - a. **Thermal Profile.** For each subplot, obtain a thermal profile using Tex-244-F. The Engineer may reduce the testing frequency based on a satisfactory test history. The Engineer may also obtain as many thermal profiles as deemed necessary. If the temperature differential is greater than 25°F, the area will be deemed as having thermal segregation. Evaluate areas with thermal segregation by performing a density profile in accordance with Section 344.4.I.3.c(2),

“Segregation (Density Profile).” Take corrective action to eliminate areas that have thermal segregation. Unless otherwise directed, suspend operations if the maximum temperature differential exceeds 50°F. Resume operations when the Engineer determines that subsequent production will meet the specifications.

- b. Windrow Operations.** When hot mix is placed in windrows, operate windrow pickup equipment so that substantially all the mixture deposited on the roadbed is picked up and loaded into the paver.

Table 11
Suggested Minimum Mixture Placement Temperature

High-Temperature Binder Grade	Minimum Placement Temperature (Before Entering Paver)
PG 64 or lower	260°F
PG 70	270°F
PG 76	280°F
PG 82 or higher	290°F

- H. Compaction.** Uniformly compact the pavement to the density requirements of the specification. Use the control strip method given in Tex-207-F, Part IV, to establish the rolling pattern. Do not use pneumatic-tire rollers if excessive pickup of fines by roller tires occurs. Unless otherwise directed, use only water or an approved release agent on rollers, tamps, and other compaction equipment.

Where specific air void requirements are waived, furnish and operate compaction equipment as approved. Use tamps to thoroughly compact the edges of the pavement along curbs, headers, and similar structures and in locations that will not allow thorough compaction with rollers. The Engineer may require rolling with a trench roller on widened areas, in trenches, and in other limited areas.

Compact RBL mixtures to achieve a maximum in-place air void value of 4.0%. Core each subplot of the RBL and determine the in-place air voids. Investigate air void deficiencies and take corrective actions during production and placement to achieve required air voids. Suspend production if 2 consecutive sublots fail to meet the air void requirement, unless otherwise approved. Resume production after the Engineer approves changes to production or placement methods.

Allow the compacted pavement to cool to 160°F or lower before opening to traffic unless otherwise directed. When directed, sprinkle

344.4 to 344.4

the finished mat with water or limewater to expedite opening the roadway to traffic.

- I. **Acceptance Plan.** Sample and test the hot mix on a lot and subplot basis. If the production pay factor for 3 consecutive lots or the placement pay factor for 3 consecutive lots is below 1.000, suspend production until test results or other information indicate, to the satisfaction of the Engineer, that the next material produced or placed will meet the specified values. Pay adjustments for the material will be in accordance with Article 344.6, "Payment."

1. **Referee Testing.** The Construction Division is the referee laboratory. The Contractor may request referee testing if a "remove and replace" condition is determined based on the Engineer's test results, or if the differences between Contractor and Engineer test results exceed the maximum allowable difference shown in Table 9 and the differences cannot be resolved. Make the request within 5 working days after receiving test results and cores from the Engineer. Referee tests will be performed only on the subplot in question and only for the particular test in question. Allow 10 working days from the time the samples are received at the referee laboratory for test results to be reported. The Department may require the Contractor to reimburse the Department for referee tests if more than 3 referee tests per project are required and the Engineer's test results are closer than the Contractor's test results to the referee test results.

The Construction Division will determine the laboratory-molded density based on the molded specific gravity and the maximum theoretical specific gravity of the referee sample. The in-place air voids will be determined based on the bulk specific gravity of the cores, as determined by the referee laboratory, and the Engineer's average maximum theoretical specific gravity for the lot. With the exception of remove and replace conditions, referee test results are final and will establish pay adjustment factors for the subplot in question. Sublots subject to be removed and replaced will be further evaluated in accordance with Article 344.6, "Payment."

2. **Production Acceptance.**

- a. **Production Lot.** A production lot consists of 4 equal sublots. Lot 1 will be 1,000 tons. The Engineer will select subsequent lot sizes based on the anticipated daily production. The lot size will be at least 1,000 tons, but no greater than 4,000 tons. The

Engineer may change the lot size before the Contractor begins any lot.

The production pay factor for RBL mixtures is 1.000. Produce and test each production subplot of RBL mix to ensure the laboratory-molded density is between 97.0% to 99.0%. The Engineer may suspend production if laboratory-molded density exceeds the range on 2 consecutive sublots.

(1) Small-Quantity Production. When the anticipated daily production is less than 500 tons or the total production for the project is less than 5,000 tons, the Engineer may waive all quality control and quality assurance (QC/QA) sampling and testing requirements. If the Engineer waives QC/QA sampling and testing, both production and placement pay factors will be 1.000. However, the Engineer will retain the right to perform random acceptance tests for production and placement and may reject objectionable materials and workmanship.

When the Engineer waives all QC/QA sampling and testing requirements:

- produce, haul, place and compact the mixture as directed by the Engineer;
- control mixture production to yield a laboratory-molded density of 96.0% \pm 1.0% as tested by the Engineer; and
- compact the mixture to yield in-place air voids that are greater than or equal to 2.7% and less than or equal to 9.0% as tested by the Engineer.

(2) Incomplete Production Lots. If a lot is begun but cannot be completed, such as on the last day of production or in other circumstances deemed appropriate, the Engineer may close the lot. Adjust the payment for the incomplete lot in accordance with Section 344.6.A, "Production Pay Adjustment Factors."

b. Production Sampling.

(1) Mixture Sampling. At the beginning of the project, the Engineer will select random numbers for all production sublots. Determine sample locations in accordance with Tex-225-F.

Obtain hot mix samples from trucks at the plant in accordance with Tex-222-F. For each subplot, take 1 sample at the location randomly selected. For each lot, the Engineer will randomly select and test a “blind” sample from at least 1 subplot. The location of the Engineer’s “blind” sample will not be disclosed to the Contractor. The Engineer will use the Contractor’s split sample for sublots not sampled by the Engineer.

The sampler will split each sample into 3 equal portions in accordance with Tex-200-F and label these portions as “Contractor,” “Engineer,” and “Referee.” Deliver the samples to the appropriate party’s laboratory. Deliver referee samples to the Engineer. Discard unused samples after accepting pay adjustment factors for that lot.

- (2) **Asphalt Binder Sampling.** Obtain a 1-qt. sample of the asphalt binder for each subplot of mixture produced. Obtain the sample at approximately the same time the mixture random sample is obtained. Sample from a port located immediately upstream from the mixing drum or pug mill. Take the sample in accordance with the pipeline sampling procedure given in Tex-500-C, Part II. Label the can with the corresponding lot and subplot numbers, and deliver the sample to the Engineer.

The Engineer may also obtain independent samples. If the Engineer chooses to obtain an independent asphalt binder sample, the Engineer will split a sample of the asphalt binder with the Contractor. The Engineer will test at least 1 asphalt binder sample per project to verify compliance with Item 300, “Asphalts, Oils, and Emulsions.”

- c. **Production Testing.** The Contractor and Engineer must perform production tests in accordance with Table 12. The Contractor has the option to verify the Engineer’s test results on split samples provided by the Engineer. Determine compliance with operational tolerances listed in Table 9 for all sublots.

If the aggregate mineralogy is such that Tex-236-F does not yield reliable results, the Engineer may allow alternate methods for determining the asphalt content and aggregate gradation. Unless otherwise allowed, the Engineer will require the Contractor to provide evidence that results from

Tex-236-F are not reliable before permitting an alternate method. If an alternate test method is allowed, use the applicable test procedure as directed.

Table 12
Production and Placement Testing Frequency

Description	Test Method	Minimum Contractor Testing Frequency	Minimum Engineer Testing Frequency
Individual % retained for #8 sieve and larger	Tex-200-F or Tex-236-F	1 per subplot	1 per 12 sublots
Individual % retained for sieves smaller than #8 and larger than #200			
% passing the #200 sieve	Tex-207-F	N/A	1 per subplot
Laboratory-molded density			
VMA			
Laboratory-molded bulk specific gravity			
In-Place air voids	Tex-207-F, Part V	1 per subplot	1 per project
Segregation (density profile)			
Longitudinal joint density	Tex-207-F, Part VII		
Moisture content	Tex-212-F, Part II	When directed	
Theoretical maximum specific (Rice) gravity	Tex-227-F	N/A	1 per subplot
Asphalt content	Tex-236-F	1 per subplot	1 per lot
Hamburg Wheel test	Tex-242-F	N/A	1 per project
Thermal profile	Tex-244-F	1 per subplot	
Asphalt binder sampling and testing ¹	Tex-500-C	1 per subplot (sample only)	
Boil test ¹	Tex-530-C	1 per lot	

1. The Engineer may reduce or waive the sampling and testing requirements based on a satisfactory test history.

- d. Operational Tolerances.** Control the production process within the operational tolerances listed in Table 9. When production is suspended, the Engineer will allow production to resume when test results or other information indicates the next mixture produced will be within the operational tolerances.

- (1) Gradation.** Unless otherwise directed, suspend production when either the Contractor's or the Engineer's test results for gradation exceed the operational tolerances for 3 consecutive sublots on the same sieve or 4 consecutive sublots on any sieve. The consecutive sublots may be from more than 1 lot.

- (2) **Asphalt Content.** No production or placement bonus will be paid for any lot that has 2 or more sublots within a lot that are out of operational tolerance for asphalt content based on either the Contractor's or the Engineer's test results. Suspend production and shipment of mixture if the asphalt content deviates from the current JMF by more than 0.5% for any subplot.
- (3) **Hamburg Wheel Test.** The Engineer may perform a Hamburg Wheel test at any time during production, including when the boil test indicates a change in quality from the materials submitted for JMF1. In addition to testing production samples, the Engineer may obtain cores and perform Hamburg Wheel tests on any area of the roadway where rutting is observed. When the production or core samples fail the Hamburg Wheel test criteria in Table 8, suspend production until further Hamburg Wheel tests meet the specified values. Core samples, if taken, will be obtained from the center of the finished mat or other areas excluding the vehicle wheel path. The Engineer may require up to the entire subplot of any mixture failing the Hamburg Wheel test to be removed and replaced at the Contractor's expense.

If the Department's or approved laboratory's Hamburg Wheel test results in a "remove and replace" condition, the Contractor may request that the Department confirm the results by retesting the failing material. The Construction Division will perform the Hamburg Wheel tests and determine the final disposition of the material in question based on the Department's test results.

- e. **Individual Loads of Hot Mix.** The Engineer can reject individual truckloads of hot mix. When a load of hot mix is rejected for reasons other than temperature, the Contractor may request that the rejected load be tested. Make this request within 4 hr. of rejection. The Engineer will sample and test the mixture. If test results are within the operational tolerances shown in Table 9, payment will be made for the load. If test results are not within operational tolerances, no payment will be made for the load and the Engineer may require removal.

3. Placement Acceptance.

- a. **Placement Lot.** A placement lot consists of 4 placement sublots. A placement subplot consists of the area placed during a production subplot. The placement pay factor for RBL mixtures is 1.000. The Engineer may suspend production of the RBL if the in-place air voids exceed 4.0% on 2 consecutive sublots.
- (1) **Lot 1 Placement.** Placement bonuses for Lot 1 will be in accordance with Section 344.6.B, "Placement Pay Adjustment Factors." However, no placement penalty will be assessed for any subplot placed in Lot 1 when the in-place air voids are greater than or equal to 2.7% and less than or equal to 9.0%. Remove and replace any subplot with in-place air voids less than 2.7% or greater than 9.0%.
 - (2) **Incomplete Placement Lots.** An incomplete placement lot consists of the area placed as described in Section 344.4.I.2.a(2), "Incomplete Production Lot," excluding miscellaneous areas as defined in Section 344.4.I.3.a(4), "Miscellaneous Areas." Placement sampling is required if the random sample plan for production resulted in a sample being obtained from an incomplete production subplot.
 - (3) **Shoulders and Ramps.** Shoulders and ramps are subject to in-place air void determination and pay adjustments, unless otherwise shown on the plans.
 - (4) **Miscellaneous Areas.** Miscellaneous areas include areas that are not generally subject to primary traffic, such as driveways, mailbox turnouts, crossovers, gores, spot level-up areas, and other similar areas. Miscellaneous areas also include level-ups and thin overlays if the layer thickness designated on the plans is less than the compacted lift thickness shown in Table 10. Miscellaneous areas are not eligible for random placement sampling locations, and will receive a 1.000 placement pay factor. Compact areas that are not subject to in-place air void determination in accordance with Section 344.4.H, "Compaction."

- b. Placement Sampling.** At the beginning of the project, the Engineer will select random numbers for all placement sublots. The Engineer will provide the Contractor with the placement random numbers immediately after the subplot is completed. Mark the roadway location at the completion of each subplot and record the station number. Determine 1 random sample location for each placement subplot in accordance with Tex-225-F. If the randomly generated sample location is within 2 ft. of a joint or pavement edge, adjust the location by no more than necessary to achieve a 2-ft. clearance.

Shoulders and ramps are always eligible for selection as a random sample location. However, if a random sample location falls on a shoulder or ramp that is designated on the plans as not subject to in-place air void testing, cores will not be taken for the subplot and a 1.000 pay factor will be assigned to that subplot.

Unless otherwise determined, the Engineer will witness the coring operation and measurement of the core thickness. Unless otherwise approved, obtain the cores within 1 working day of the time the placement subplot is completed. Obtain two 6-in.-diameter cores side-by-side from within 1 ft. of the random location provided for the placement subplot. Mark the cores for identification. Visually inspect each core and verify that the current paving layer is bonded to the underlying layer. If an adequate bond does not exist between the current and underlying layer, take corrective action to insure that an adequate bond will be achieved during subsequent placement operations. For SP-C, SP-D, and CMHB-F mixtures, 4-in.-diameter cores are allowed.

Immediately after obtaining the cores, dry the core holes and tack the sides and bottom. Fill the hole with the same type of mixture and properly compact the mixture. Repair core holes with other methods when approved.

If the core heights exceed the minimum untrimmed values listed in Table 10, trim and deliver the cores to the Engineer within 1 working day following placement operations unless otherwise approved.

If the core height before trimming is less than the minimum untrimmed value shown in Table 10, decide whether or not to

include the pair of cores in the air void determination for that subplot. If the cores are to be included in air void determination, trim the cores before delivering to the Engineer. If the cores will not be included in air void determination, deliver untrimmed cores to the Engineer. The placement pay factor for the subplot will be 1.000 if cores will not be included in air void determination.

- c. Placement Testing.** Perform placement tests in accordance with Table 12. After the Engineer returns the cores, the Contractor has the option to test the cores to verify the Engineer's test results for in-place air voids. Re-dry the cores to constant weight before testing. The allowable differences between the Contractor's and Engineer's test results are listed in Table 9.
- (1) In-Place Air Voids.** The Engineer will measure in-place air voids in accordance with Tex-207-F and Tex-227-F. Before drying to a constant weight, cores may be predried using a Corelok or similar vacuum device to remove excess moisture. The Engineer will average the values obtained for all sublots in the production lot to determine the theoretical maximum specific gravity. The Engineer will use the average air void content of the 2 cores to calculate a placement pay adjustment factor.
- The Engineer will use paraffin coating or vacuum methods to seal the core if required by Tex-207-F. The Engineer will use the test results from the unsealed core to determine the placement pay adjustment factor if the sealed core yields a higher specific gravity than the unsealed core. After determining the in-place air void content, the Engineer will return the cores and provide test results to the Contractor.
- (2) Segregation (Density Profile).** Test for segregation using density profiles in accordance with Tex-207-F, Part V. Provide the Engineer with the results of the density profiles as they are completed. Areas defined in Section 344.4.I.3.a(4), "Miscellaneous Areas," are not subject to density profile testing.
- Unless otherwise approved, perform a density profile every time the screed stops, on areas that are identified by either the Contractor or the Engineer as having thermal

segregation, and on any visibly segregated areas. If the screed does not stop, and there are no visibly segregated areas or areas that are identified as having thermal segregation, perform a minimum of 1 profile per subplot. Reduce the test frequency to a minimum of 1 profile per lot if 4 consecutive profiles are within established tolerances. Continue testing at a minimum frequency of 1 per lot unless a profile fails, at which point resume testing at a minimum frequency of 1 per subplot. The Engineer may further reduce the testing frequency based on a consistent pattern of satisfactory results.

The density profile is considered failing if it exceeds the tolerances in Table 13. No production or placement bonus will be paid for any subplot that contains a failing density profile. The Engineer may make as many independent density profile verifications as deemed necessary. The Engineer’s density profile results will be used when available.

Investigate density profile failures and take corrective actions during production and placement to eliminate the segregation. Suspend production if 2 consecutive density profiles fail, unless otherwise approved. Resume production after the Engineer approves changes to production or placement methods.

**Table 13
Segregation (Density Profile) Acceptance Criteria**

Mixture Type	Maximum Allowable Density Range (Highest to Lowest)	Maximum Allowable Density Range (Average to Lowest)
SP-A & SP-B	8.0 pcf	5.0 pcf
SP-C & SP-D CMHB-C & CMHB-F	6.0 pcf	3.0 pcf

(3) Longitudinal Joint Density.

- (a) Informational Tests.** While establishing the rolling pattern, perform joint density evaluations and verify that the joint density is no more than 3.0 pcf below the density taken at or near the center of the mat. Adjust the rolling pattern if needed to achieve the desired joint density. Perform additional joint density

evaluations at least once per subplot unless otherwise directed.

- (b) Record Tests.** For each subplot, perform a joint density evaluation at each pavement edge that is or will become a longitudinal joint. Determine the joint density in accordance with Tex-207-F, Part VII. Record the joint density information and submit results, on Department forms, to the Engineer. The evaluation is considered failing if the joint density is more than 3.0 pcf below the density taken at the core random sample location and the correlated joint density is less than 90.0%. The Engineer may make independent joint density verifications at the random sample locations. The Engineer's joint density test results will be used when available.

Investigate joint density failures and take corrective actions during production and placement to improve the joint density. Suspend production if 2 consecutive evaluations fail unless otherwise approved. Resume production after the Engineer approves changes to production or placement methods.

- (4) Recovered Asphalt DSR.** The Engineer may take production samples or cores from suspect areas of the project to determine recovered asphalt properties. Asphalt binders with an aging ratio greater than 3.5 do not meet the requirements for recovered asphalt properties and may be deemed defective when tested and evaluated by the Construction Division. The aging ratio is the dynamic shear rheometer (DSR) value of the extracted binder divided by the DSR value of the original unaged binder (including RAP binder). DSR values are obtained according to AASHTO T 315 at the specified high temperature performance grade of the asphalt. The binder from RAP will be included proportionally as part of the original unaged binder. The Engineer may require removal and replacement of the defective material at the Contractor's expense. The asphalt binder will be recovered for testing from production samples or cores using Tex-211-F.

344.5 to 344.6

- (5) **Irregularities.** Immediately take corrective action if surface irregularities, including but not limited to segregation, rutting, raveling, flushing, fat spots, mat slippage, color, texture, roller marks, tears, gouges, streaks, or uncoated aggregate particles, are detected.

The Engineer may allow placement to continue for at most 1 day of production while taking appropriate action. If the problem still exists after that day, suspend paving until the problem is corrected to the satisfaction of the Engineer.

At the expense of the Contractor and to the satisfaction of the Engineer, remove and replace any mixture that does not bond to the existing pavement or that has other surface irregularities identified above.

4. **Ride Quality.** Unless otherwise shown on the plans, measure ride quality in accordance with Item 585, "Ride Quality for Pavement Surfaces."

344.5. Measurement. Hot mix will be measured by the ton of composite hot mix, which includes asphalt, aggregate, and additives. Measure on scales in accordance with Item 520, "Weighing and Measuring Equipment."

344.6. Payment. The work performed and materials furnished in accordance with this Item and measured as provided under Article 344.5, "Measurement," will be paid for at the unit price bid for "Performance Design Mixtures," of the mixture type, surface aggregate classification, and binder specified. Pay adjustments for bonuses and penalties will be applied as determined in this Item. These prices are full compensation for surface preparation, materials including tack coat, placement, equipment, labor, tools, and incidentals.

Trial batches will not be paid for unless they are included in pavement work approved by the Department.

Pay adjustment for ride quality will be determined in accordance with Item 585, "Ride Quality for Pavement Surfaces."

- A. **Production Pay Adjustment Factors.** The production pay adjustment factor is based on the laboratory-molded density using the Engineer's test results. A pay adjustment factor will be determined from Table 14 for each subplot using the deviation from the target laboratory-molded density defined in Table 8. The production pay adjustment factor for

completed lots will be the average of the pay adjustment factors for the 4 sublots sampled within that lot.

Table 14
Production Pay Adjustment Factors for Laboratory-Molded Density

Absolute Deviation from Target Laboratory-Molded Density	Production Pay Adjustment Factor
0.0	1.075
0.1	1.075
0.2	1.075
0.3	1.066
0.4	1.057
0.5	1.047
0.6	1.038
0.7	1.029
0.8	1.019
0.9	1.010
1.0	1.000
1.1	0.900
1.2	0.800
1.3	0.700
> 1.3	Remove and replace

1. **Incomplete Production Lots.** Production pay adjustments for incomplete lots, described under Section 344.4.I.2.a.(2), “Incomplete Production Lots,” will be calculated using the average production pay factors from all sublots sampled. A production pay factor of 1.000 will be assigned to any lot when the random sampling plan did not result in collection of any samples.
 2. **Production Sublots Subject to Removal and Replacement.** If after referee testing, the laboratory-molded density for any subplot results in a “remove and replace” condition as listed in Table 14, the Engineer may require removal and replacement, or may allow the subplot to be left in place without payment. Replacement material meeting the requirements of this Item will be paid for in accordance with this Article.
- B. Placement Pay Adjustment Factors.** The placement pay adjustment factor is based on in-place air voids using the Engineer’s test results. A pay adjustment factor will be determined from Table 15 for each subplot that requires in-place air void measurement. A placement pay adjustment factor of 1.000 will be assigned to the entire subplot when the random sample location falls in an area on a ramp or shoulder not

subject to in-place air void testing. A placement pay adjustment factor of 1.000 will be assigned to quantities placed in miscellaneous areas as described in Section 344.4.I.3.a.(4), "Miscellaneous Areas." The placement pay adjustment factor for completed lots will be the average of the placement pay adjustment factors for the 4 sublots within that lot.

Table 15
Placement Pay Adjustment Factors for In-Place Air Voids

In-Place Air Voids	Pay Adjustment Factor	In-Place Air Voids	Pay Adjustment Factor
< 2.7	Remove and Replace	5.9	1.048
2.7	0.695	6.0	1.045
2.8	0.715	6.1	1.042
2.9	0.735	6.2	1.039
3.0	0.755	6.3	1.036
3.1	0.775	6.4	1.033
3.2	0.795	6.5	1.030
3.3	0.815	6.6	1.027
3.4	0.835	6.7	1.024
3.5	0.855	6.8	1.021
3.6	0.875	6.9	1.018
3.7	0.895	7.0	1.015
3.8	0.915	7.1	1.012
3.9	0.935	7.2	1.009
4.0	0.955	7.3	1.006
4.1	0.975	7.4	1.003
4.2	0.995	7.5	1.000
4.3	1.015	7.6	0.980
4.4	1.035	7.7	0.960
4.5	1.055	7.8	0.940
4.6	1.075	7.9	0.920
4.7	1.075	8.0	0.900
4.8	1.075	8.1	0.880
4.9	1.075	8.2	0.860
5.0	1.075	8.3	0.840
5.1	1.072	8.4	0.820
5.2	1.069	8.5	0.800
5.3	1.066	8.6	0.780
5.4	1.063	8.7	0.760
5.5	1.060	8.8	0.740
5.6	1.057	8.9	0.720
5.7	1.054	9.0	0.700
5.8	1.051	> 9.0	Remove and Replace

A placement pay adjustment factor of 1.000 will be assigned to all sublots for mixtures designated on the plans as “rich bottom layer.” Cores from “rich bottom layer” mixtures are subject to specification requirements described in Section 344.4.H, “Compaction.”

- 1. Incomplete Placement Lots.** Pay adjustments for incomplete placement lots described under Section 344.4.I.3.a.(2), “Incomplete Placement Lots,” will be calculated using the average of the placement pay factors from all sublots sampled and sublots where the random location falls in an area on a ramp or shoulder not eligible for testing. A placement pay adjustment factor of 1.000 will be assigned to any lot when the random sampling plan did not result in collection of any samples.
- 2. Placement Sublots Subject to Removal and Replacement.** If after referee testing the placement pay adjustment factor for any subplot results in a “remove and replace” condition as listed in Table 15, the Engineer will choose the location of 2 cores to be taken within 3 ft. of the original failing core location. The Contractor will obtain the cores in the presence of the Engineer. The Engineer will submit the cores to the Materials and Pavements Section of the Construction Division where they will be tested for bulk specific gravity within 10 working days of receipt. The average bulk specific gravity of the cores will be divided by the Engineer’s average maximum theoretical specific gravity for that lot to determine the new pay adjustment factor of the subplot in question. If the new pay adjustment factor is 0.700 or greater, then the new pay adjustment factor will apply to that subplot. If the new pay adjustment factor is less than 0.700, no payment will be made for the subplot. Remove and replace the failing subplot. Replacement material meeting the requirements of this Item will be paid for in accordance with this Article.

346.1 to 346.2

- C. Total Adjustment Pay Calculation.** Total adjustment pay (TAP) will be based on the applicable pay adjustment factors for production and placement for each lot.

$$TAP = (A + B)/2$$

where:

A = Bid price × production lot quantity × average pay adjustment factor for the production lot

B = Bid price × placement lot quantity × average pay adjustment factor for the placement lot + (bid price × miscellaneous quantities × 1.000).

ITEM 346

STONE-MATRIX ASPHALT

346.1. Description. Construct a pavement layer composed of a compacted stone-matrix asphalt (SMA) or stone-matrix asphalt rubber (SMAR) mixture of aggregate, asphalt binder, and additives mixed hot in a mixing plant.

346.2. Materials. Furnish uncontaminated materials of uniform quality that meet the requirements of the plans and specifications.

Notify the Engineer of all material sources. Notify the Engineer before changing any material source or formulation. When the Contractor makes a source or formulation change, the Engineer will verify that the requirements of this Item are met and may require a new laboratory mixture design, trial batch, or both. The Engineer may sample and test project materials at any time during the project to verify compliance.

- A. Aggregate.** Furnish aggregates from sources that conform to the requirements shown in Table 1, and as specified in this Section, unless otherwise shown on the plans. Provide aggregate stockpiles that meet the definition in this Section for either a coarse aggregate or fine aggregate. When reclaimed asphalt pavement (RAP) is allowed by plan note, provide RAP stockpiles in accordance with this Section. Aggregate from RAP is not required to meet Table 1 requirements unless otherwise shown on the plans. Supply mechanically crushed gravel or stone aggregates that meet the definitions in Tex-100-E. The Engineer will designate the plant or the quarry as the sampling location. Samples must be from materials produced for the project. The Engineer will establish the surface aggregate classification (SAC) and perform

Los Angeles abrasion, magnesium sulfate soundness, and Micro-Deval tests. Perform all other aggregate quality tests listed in Table 1. Document all test results on the mixture design report. The Engineer may perform tests on independent or split samples to verify Contractor test results. Stockpile aggregates for each source and type separately. Determine aggregate gradations for mixture design and production testing based on the washed sieve analysis given in Tex-200-F, Part II. Do not add material to an approved stockpile from sources that do not meet the aggregate quality requirements of the Department's *Bituminous Rated Source Quality Catalog* (BRSQC) unless otherwise approved.

1. **Coarse Aggregate.** Coarse aggregate stockpiles must have no more than 20% material passing the No. 8 sieve. Provide aggregates from sources listed in the BRSQC. Provide aggregate from nonlisted sources only when tested by the Engineer and approved before use. Allow 30 calendar days for the Engineer to sample, test, and report results for nonlisted sources.

Provide coarse aggregate with at least the minimum SAC shown on the plans. SAC requirements only apply to aggregates used on the surface of travel lanes, unless otherwise shown on the plans. The SAC for sources on the Department's Aggregate Quality Monitoring Program (AQMP) is listed in the BRSQC.

Class B aggregate meeting all other requirements in Table 1 may be blended with a Class A aggregate in order to meet requirements for Class A materials. When blending Class A and B aggregates to meet a Class A requirement, ensure that at least 50% by weight of the material retained on the No. 4 sieve comes from the Class A aggregate source. Blend by volume if the bulk specific gravities of the Class A and B aggregates differ by more than 0.300. When blending, do not use Class C or D aggregates. For blending purposes, coarse aggregate from RAP will be considered as Class B aggregate.

2. **RAP.** RAP is salvaged, milled, pulverized, broken, or crushed asphalt pavement. Crush or break RAP so that 100% of the particles pass the 2-in. sieve.

RAP from either Contractor- or Department-owned sources, including RAP generated during the project, is permitted only when shown on the plans. Department-owned RAP, if allowed for use, will be available at the location shown on the plans. When RAP is used, determine asphalt content and gradation for mixture

design purposes. Perform other tests on RAP when shown on the plans. When RAP is allowed by plan note, use no more than 20% RAP unless otherwise shown on the plans.

Do not use RAP contaminated with dirt or other objectionable materials. Do not use the RAP if the decantation value exceeds 5% and the plasticity index is greater than 8. Test the stockpiled RAP for decantation in accordance with the laboratory method given in Tex-406-A, Part I. Determine the plasticity index using Tex-106-E if the decantation value exceeds 5%. The decantation and plasticity index requirements do not apply to RAP samples with asphalt removed by extraction.

Do not intermingle Contractor-owned RAP stockpiles with Department-owned RAP stockpiles. Remove unused Contractor-owned RAP material from the project site upon completion of the project. Return unused Department-owned RAP to the designated stockpile location.

- 3. Fine Aggregate.** Fine aggregates consist of manufactured sands, screenings, and field sands. Fine aggregate stockpiles must meet the gradation requirements in Table 2. Supply fine aggregates that are free from organic impurities. The Engineer may test the fine aggregate in accordance with Tex-408-A to verify the material is free from organic impurities. At most 15% of the total aggregate may be field sand or other uncrushed fine aggregate. With the exception of field sand, use fine aggregate from coarse aggregate sources that meet the requirements shown in Table 1, unless otherwise approved.

If 10% or more of the stockpile is retained on the No. 4 sieve, test the stockpile and verify that it meets the requirements in Table 1 for coarse aggregate angularity (Tex-460-A) and flat and elongated particles (Tex-280-F).

Table 1
Aggregate Quality Requirements

Property	Test Method	Requirement
Coarse Aggregate		
SAC	AQMP	As shown on plans
Deleterious material, %, max	Tex-217-F, Part I	1.0
Decantation, %, max	Tex-217-F, Part II	1.5
Micro-Deval abrasion, %, max	Tex-461-A	Note 1
Los Angeles abrasion, %, max	Tex-410-A	30
Magnesium sulfate soundness, 5 cycles, %, max	Tex-411-A	20
Coarse aggregate angularity, 2 crushed faces, %, min	Tex 460-A, Part I	95 ²
Flat and elongated particles @ 5:1, %, max	Tex-280-F	10
Fine Aggregate		
Linear shrinkage, %, max	Tex-107-E	3
Combined Aggregate³		
Sand equivalent, %, min	Tex-203-F	45

1. Not used for acceptance purposes. Used by the Engineer as an indicator of the need for further investigation.

2. Only applies to crushed gravel.

3. Aggregates, without mineral filler, RAP, or additives, combined as used in the job-mix formula (JMF).

Table 2
Gradation Requirements for Fine Aggregate

Sieve Size	% Passing by Weight or Volume
3/8"	100
#8	70–100
#200	0–30

B. Mineral Filler. Mineral filler consists of finely divided mineral matter such as agricultural lime, crusher fines, hydrated lime, cement, or fly ash. Mineral filler is allowed unless otherwise shown on the plans. Do not use more than 2% hydrated lime or cement, unless otherwise shown on the plans. The plans may require or disallow specific mineral fillers. When used, provide mineral filler that:

- is sufficiently dry, free-flowing, and free from clumps and foreign matter;
- does not exceed 3% linear shrinkage when tested in accordance with Tex-107-E; and
- meets the gradation requirements in Table 3.

Table 3
Gradation Requirements for Mineral Filler

Sieve Size	% Passing by Weight or Volume
#8	100
#200	55–100

- C. Baghouse Fines.** Fines collected by the baghouse or other dust-collecting equipment may be reintroduced into the mixing drum.
- D. Asphalt Binder.** For SMA mixtures, furnish the type and grade of PG binder and fibers specified on the plans. For SMAR mixtures, provide the A-R binder specified on the plans. Provide asphalt binder that meets requirements of Item 300, “Asphalts, Oils, and Emulsions.”
- 1. PG Binder.** When SMA is specified, provide an asphalt binder with a high-temperature grade of PG 76 and low-temperature grade as shown on the plans in accordance with Section 300.2.J, “Performance-Graded Binders.”
 - 2. A-R Binder.** When SMAR is specified, provide A-R binder that meets the Type I or Type II requirements of Section 300.2.I, “Asphalt-Rubber Binders,” unless otherwise shown on the plans. Use at least 15.0% by weight of Crumb Rubber Modifier (CRM) that meets the Grade B or Grade C requirements of Section 300.2.G, “Crumb Rubber Modifier,” unless otherwise shown on the plans.
- E. Tack Coat.** Unless otherwise shown on the plans or approved, furnish CSS-1H, SS-1H, or a PG binder with a minimum high-temperature grade of PG 58 for tack coat in accordance with Item 300. Do not dilute emulsified asphalts at the terminal, in the field, or at any other location before use.
- The Engineer will obtain at least 1 sample of the tack coat binder per project and test it to verify compliance with Item 300. The Engineer will obtain the sample from the asphalt distributor immediately before use.
- F. Additives.** When shown on the plans, use the type and rate of additive specified. Other additives that facilitate mixing or improve the quality of the mixture may be allowed when approved.
- 1. Fibers.** When PG binder is specified, provide cellulose or mineral fibers. Submit written certification to the Engineer that the fibers proposed for use meet the requirements of DMS-9204, “Fiber Additives for Bituminous Mixtures.”

2. **Antistripping Agents.** If lime or a liquid antistripping agent is used, add in accordance with Item 301, "Asphalt Antistripping Agents." Do not add lime directly into the mixing drum of any plant where lime is removed through the exhaust stream unless the plant has a baghouse or dust collection system that reintroduces the lime back into the drum.

346.3. Equipment. Provide required or necessary equipment in accordance with Item 320, "Equipment for Asphalt Concrete Pavement." When A-R binder is specified, equip the hot mix plant with an in-line viscosity-measuring device located between the blending unit and the mixing drum.

346.4. Construction. Produce, haul, place, and compact the specified paving mixture. Schedule and participate in a prepaving meeting with the Engineer as required in the Quality Control Plan (QCP).

- A. **Certification.** Personnel, certified by the Department-approved hot-mix asphalt certification program, must conduct all mixture designs, sampling, and testing in accordance with Table 4. In addition to meeting the certification requirements in Table 4, all Level II certified specialists must successfully complete an approved Superpave training course. Supply the Engineer with a list of certified personnel and copies of their current certificates before beginning production and when personnel changes are made.

Provide the following:

- a mixture design that is developed and signed by a Level II certified specialist,
 - a Level IA certified specialist at the plant during production operations, and
 - a Level IB certified specialist to conduct placement tests.
- B. **Reporting.** Use Department-provided software to record and calculate all test data. The Engineer and the Contractor shall provide any available test results to the other party when requested. The maximum allowable time for the Contractor and Engineer to exchange test data is as given in Table 5, unless otherwise approved. The Engineer and the Contractor shall immediately report to the other party any test result that requires production to be suspended, a payment penalty, or fails to meet the specification requirements. Use the approved communication method (e.g., email, diskette, hard copy) to submit test results to the Engineer.

Table 4
Test Methods, Test Responsibility, and Minimum Certification Levels

1. Aggregate Testing	Test Method	Contractor	Engineer	Level
Sampling	Tex-400-A	✓	✓	IA
Dry sieve	Tex-200-F, Part I	✓	✓	IA
Washed sieve	Tex-200-F, Part II	✓	✓	IA
Deleterious material	Tex-217-F, Part I	✓	✓	II
Decantation	Tex-217-F, Part II	✓	✓	II
Los Angeles abrasion	Tex-410-A		✓	
Magnesium sulfate soundness	Tex-411-A		✓	
Micro-Deval abrasion	Tex-461-A		✓	
Coarse aggregate angularity	Tex-460-A	✓	✓	II
Flat and elongated particles	Tex-280-F	✓	✓	II
Linear shrinkage	Tex-107-E	✓	✓	II
Sand equivalent	Tex-203-F	✓	✓	II
Organic impurities	Tex-408-A	✓	✓	II
2. Mix Design & Verification	Test Method	Contractor	Engineer	Level
Design and JMF changes	Tex-204-F	✓	✓	II
Mixing	Tex-205-F	✓	✓	II
Molding (SGC)	Tex-241-F	✓	✓	IA
Laboratory-molded density	Tex-207-F	✓	✓	IA
VMA	Tex-207-F	✓	✓	II
Rice gravity	Tex-227-F	✓	✓	IA
Ignition oven calibration ¹	Tex-236-F	✓	✓	II
Indirect tensile strength	Tex-226-F	✓	✓	II
Hamburg Wheel test	Tex-242-F	✓	✓	II
Boil test	Tex-530-C	✓	✓	IA
3. Production Testing	Test Method	Contractor	Engineer	Level
Random sampling	Tex-225-F		✓	IA
Mixture sampling	Tex-222-F	✓	✓	IA
Molding (SGC)	Tex-241-F	✓	✓	IA
Laboratory-molded density	Tex-207-F	✓	✓	IA
VMA (calculation only)	Tex-207-F	✓	✓	IA
Rice gravity	Tex-227-F	✓	✓	IA
Gradation & asphalt content ¹	Tex-236-F	✓	✓	IA
Control charts	Tex-233-F	✓	✓	IA
Moisture content	Tex-212-F	✓	✓	IA
Hamburg Wheel test	Tex-242-F	✓	✓	II
Micro-Deval abrasion	Tex-461-A		✓	
Boil test	Tex-530-C	✓	✓	IA
Aging ratio	Tex-211-F		✓	
4. Placement Testing	Test Method	Contractor	Engineer	Level
Random sampling	Tex-225-F		✓	IA
In-Place air voids	Tex-207-F	✓	✓	IA
Establish rolling pattern	Tex-207-F	✓		IB
Control charts	Tex-233-F	✓	✓	IA
Ride quality measurement	Tex-1001-S	✓	✓	IB

Table 4 (continued)
Test Methods, Test Responsibility, and Minimum Certification Levels

4. Placement Testing	Test Method	Contractor	Engineer	Level
Segregation (density profile)	Tex-207-F, Part V	✓	✓	IB
Longitudinal Joint Density	Tex-207-F, Part VII	✓	✓	IB
Thermal profile	Tex-244-F	✓	✓	IB
Tack coat adhesion	Tex-243-F		✓	IB

1. Refer to Section 344.4.1.2.c for exceptions to using an ignition oven.

Table 5
Reporting Schedule

Description	Reported By	Reported to	To Be Reported Within
Production Quality Control			
Gradation ¹ Asphalt content ¹ Laboratory-molded density ² Moisture content ³ Boil test ³	Contractor	Engineer	1 working day of completion of the subplot
Production Quality Assurance			
Gradation ³ Asphalt content ³ Laboratory-molded density ¹ Hamburg Wheel test ² Boil test ³ Binder tests ²	Engineer	Contractor	1 working day of completion of the subplot
Placement Quality Control			
In-Place air voids ² Segregation ¹ Longitudinal joint density ¹ Thermal profile ¹	Contractor	Engineer	1 hr. of performing the test for segregation, longitudinal joint density, and thermal profile
Placement Quality Assurance			
In-Place Air Voids ¹ Segregation ² Longitudinal joint density ² Thermal profile ² Aging ratio ²	Engineer	Contractor	1 working day of receipt of the trimmed cores for In-Place air voids ⁴
Pay Adjustment Summary	Engineer	Contractor	2 working days of performing all required tests and receiving Contractor test data

1. These tests are required on every subplot.
2. Optional test. To be reported as soon as results become available.
3. To be performed at the frequency shown in Table 12.
4. Additional time is allowed if cores cannot be dried to constant weight within 1 day.

The Engineer will use the Department-provided software to calculate all pay adjustment factors for the lot. Sublot samples may be discarded

346.4 to 346.4

after the Engineer and Contractor sign off on the pay adjustment summary documentation for the lot.

Use the procedures described in Tex-233-F to plot the results of all quality control (QC) and quality assurance (QA) testing. Update the control charts as soon as test results for each subplot become available. Make the control charts readily accessible at the field laboratory. The Engineer may suspend production for failure to update control charts.

- C. **QCP.** Develop and follow the QCP in detail. Obtain approval from the Engineer for changes to the QCP made during the project. The Engineer may suspend operations if the Contractor fails to comply with the QCP.

Submit a written QCP to the Engineer before the mandatory prepaving meeting. Receive the Engineer's approval of the QCP before beginning production. Include the following items in the QCP.

1. **Project Personnel.** For project personnel, include:
 - a list of individuals responsible for QC with authority to take corrective action and
 - contact information for each individual listed.
2. **Material Delivery and Storage.** For material delivery and storage, include:
 - the sequence of material processing, delivery, and minimum quantities to assure continuous plant operations;
 - aggregate stockpiling procedures to avoid contamination and segregation;
 - frequency, type, and timing of aggregate stockpile testing to assure conformance of material requirements before mixture production; and
 - procedure for monitoring the quality and variability of asphalt binder.
3. **Production.** For production, include:
 - loader operation procedures to avoid contamination in cold bins,
 - procedures for calibrating and controlling cold feeds,
 - procedures to eliminate debris or oversized material,
 - procedures for adding and verifying rates of each applicable mixture component (e.g., aggregate, asphalt binder, RAP, lime, liquid antistriper),
 - procedures for reporting job control test results, and
 - procedures to avoid segregation and drain-down in the silo.

4. **Loading and Transporting.** For loading and transporting, include:
 - type and application method for release agents and
 - truck loading procedures to avoid segregation.
5. **Placement and Compaction.** For placement and compaction, include:
 - proposed agenda for mandatory prepaving meeting including date and location;
 - type and application method for release agents in the paver and on rollers, shovels, lutes, and other utensils;
 - procedures for the transfer of mixture into the paver while avoiding segregation and preventing material spillage;
 - process to balance production, delivery, paving, and compaction to achieve continuous placement operations;
 - paver operations (e.g., operation of wings, height of mixture in auger chamber) to avoid physical and thermal segregation and other surface irregularities; and
 - procedures to construct quality longitudinal and transverse joints.

D. Mixture Design.

1. **Design Requirements.** Unless otherwise shown on the plans, use the SMA or SMAR design procedures given in Tex-204-F, Part VI or Part VII, to design a mixture meeting the requirements listed in Tables 1, 2, 3, 6, 7, and 8. Use an approved laboratory to perform the Hamburg Wheel test and provide results with the mixture design or provide the laboratory mixture and request that the Department perform the Hamburg Wheel test. The Construction Division maintains a list of approved laboratories. The Engineer will be allowed 10 working days to provide the Contractor with Hamburg Wheel test results on the laboratory mixture design.

The Contractor may submit a new mixture design at any time during the project. The Engineer will approve all mixture designs before the Contractor can begin production. When shown on the plans, the Engineer will provide the mixture design.

The design number of gyrations (N^{des}) may be increased from 75 to 100 when allowed by the Engineer.

Provide the Engineer with a mixture design report using Department-provided software. Include the following items in the report:

346.4 to 346.4

- the combined aggregate gradation, source, specific gravity, and percent of each material used;
- results of all applicable tests;
- the mixing and molding temperatures;
- the signature of the Level II person or persons that performed the design;
- the date the mixture design was performed; and
- a unique identification number for the mixture design.

Table 6
Master Gradation Bands (% Passing by Weight or Volume)
and Volumetric Properties

Sieve Size	SMA-C Coarse	SMA-D Medium	SMA-F Fine	SMAR-C Coarse	SMAR-F Fine
3/4"	100.0	100.0	100.0	100.0	100.0
1/2"	80.0–90.0	85.0–99.0	100.0	72.0–85.0	100.0
3/8"	25.0–60.0	50.0–75.0	70.0–90.0	50.0–70.0	95.0–100.0
#4	20.0–28.0	20.0–32.0	30.0–50.0	30.0–45.0	40.0–50.0
#8	14.0–20.0	16.0–28.0	20.0–30.0	17.0–27.0	17.0–27.0
#16	8.0–20.0	8.0–28.0	8.0–30.0	12.0–22.0	12.0–22.0
#30	8.0–20.0	8.0–28.0	8.0–30.0	8.0–20.0	8.0–20.0
#50	8.0–20.0	8.0–28.0	8.0–30.0	6.0–15.0	6.0–15.0
#200	8.0–12.0	8.0–12.0	8.0–14.0	5.0–9.0	5.0–9.0
Design VMA¹, % Minimum					
	17.5	17.5	17.5	19.0	19.0
Plant-Produced VMA¹, % Minimum					
	17.0	17.0	17.0	18.5	18.5

1. Voids in mineral aggregates.

Table 7
Laboratory Mixture Design Properties

Mixture Property	Minimum		Maximum		Test Procedure
	SMA Mix	SMAR Mix	SMA Mix	SMAR Mix	
Design gyrations, N_{des}	75	75	75	75	–
Target laboratory-molded density, %	96.0	97.0	96.0	97.0	Tex-207-F
Asphalt binder content ¹ , %	6.0	7.0	–	10.0	–
Drain-down, %	–	–	0.20	0.20	Tex-235-F
Fiber content, % by wt. of total mixture	0.20	–	0.50	–	Calculated
CRM content, % by wt. of A-R binder	–	15.0	–	–	Calculated
Hamburg Wheel test ² , rut depth @ 20,000 passes tested @ 122°F, in.	–	–	0.50	0.50	Tex-242-F
Tensile strength (dry), psi (molded to 93% ±1% density)	85	85	200 ³	200	Tex-226-F
Boil test ⁴	–	–	–	–	Tex-530-C

1. When SMA mix cannot be designed with a minimum asphalt content of 6.0%, using the available aggregates, follow the guidelines in Table 8 to establish a minimum asphalt content requirement based on the combined aggregate bulk specific gravity.
2. For SMAR mixes, the number of passes required for the Hamburg Wheel test may be decreased. Other tests may be required for SMAR mixes instead of or in addition to the Hamburg Wheel test, when shown on the plans.
3. May exceed 200 psi when approved and may be waived when approved.
4. Used to establish baseline for comparison to production results. May be waived when approved.

Table 8
Guide to Adjust Minimum Asphalt Content
Based on Bulk Specific Gravity of Aggregates

Combined Aggregate Bulk Specific Gravity	Minimum Asphalt Content %
≤ 2.75	6.0
2.80	5.9
2.85	5.8
2.90	5.7
2.95	5.6
3.00	5.5

2. **Job-Mix Formula Approval.** The job-mix formula (JMF) is the combined aggregate gradation and target asphalt percentage used to establish target values for hot mix production. JMF1 is the original laboratory mixture design used to produce the trial batch. The Engineer and the Contractor will verify JMF1 based on plant-produced mixture from the trial batch unless otherwise approved. The Engineer may accept an existing mixture design previously

used on a Department project and may waive the trial batch to verify JMF1.

a. Contractor's Responsibilities.

- (1) **Providing Superpave Gyrotory Compactor.** Furnish a Superpave gyrotory compactor (SGC), calibrated in accordance with Tex-241-F, for molding production samples. Locate the SGC at the Engineer's field laboratory and make the SGC available to the Engineer for use in molding production samples.
- (2) **Gyrotory Compactor Correlation Factors.** Use Tex-206-F, Part II, to perform a gyrotory compactor correlation when the Engineer uses a different SGC. Apply the correlation factor to all subsequent production test results.
- (3) **Submitting JMF1.** Furnish the Engineer a mix design report (JMF1) and request approval to produce the trial batch. If opting to have the Department perform the Hamburg Wheel test on the laboratory mixture, provide the Engineer with approximately 10,000 g of the design mixture and request that the Department perform the Hamburg Wheel test.
- (4) **Supplying Aggregates.** Provide the Engineer with approximately 40 lb. of each aggregate stockpile unless otherwise directed.
- (5) **Supplying Asphalt.** Provide the Engineer at least 1 gal. of the asphalt material and sufficient quantities of any additives proposed for use.
- (6) **Ignition Oven Correction Factors.** Determine the aggregate and asphalt correction factors from the ignition oven using Tex-236-F. Provide the Engineer with split samples of the mixtures and blank samples used to determine the correction factors.
- (7) **Boil Test.** Perform the test and retain the tested sample from Tex-530-C. Use this sample for comparison purposes during production. The Engineer may waive the requirement for the boil test.
- (8) **Trial Batch Approval.** Upon receiving conditional approval of JMF1 from the Engineer, provide a

plant-produced trial batch for verification testing of JMF1 and development of JMF2.

- (9) **Trial Batch Production Equipment.** To produce the trial batch, use only equipment and materials proposed for use on the project.
- (10) **Trial Batch Quantity.** Produce enough quantity of the trial batch to ensure that the mixture is representative of JMF1.
- (11) **Number of Trial Batches.** Produce trial batches as necessary to obtain a mixture that meets the requirements in Table 9.
- (12) **Trial Batch Sampling.** Obtain a representative sample of the trial batch and split it into 3 equal portions in accordance with Tex-222-F. Label these portions as “Contractor,” “Engineer,” and “Referee.” Deliver samples to the appropriate laboratory as directed.
- (13) **Trial Batch Testing.** Test the trial batch to ensure the mixture produced using the proposed JMF1 meets the verification testing requirements for gradation, asphalt content, laboratory-molded density, and VMA listed in Table 9 and is in compliance with the Hamburg Wheel test requirement in Table 7. Use a Department-approved laboratory to perform the Hamburg Wheel test on the trial batch mixture or request that the Department perform the Hamburg Wheel test. The Engineer will be allowed 10 working days to provide the Contractor with Hamburg Wheel test results on the trial batch. Provide the Engineer with a copy of the trial batch test results.
- (14) **Development of JMF2.** After the Engineer grants full approval of JMF1 based on results from the trial batch, evaluate the trial batch test results, determine the optimum mixture proportions, and submit as JMF2.
- (15) **Mixture Production.** After receiving approval for JMF2 and receiving a passing result from the Department’s or a Department-approved laboratory’s Hamburg Wheel test on the trial batch, use JMF2 to produce Lot 1 as described in Section 346.4.I.3.a(1), “Lot 1 Placement.” As an option, once JMF2 is approved, proceed to Lot 1 production at the Contractor’s risk without receiving the

results from the Department's Hamburg Wheel test on the trial batch.

If electing to proceed without Hamburg Wheel test results from the trial batch, notify the Engineer. Note that the Engineer may require up to the entire subplot of any mixture failing the Hamburg Wheel test be removed and replaced at the Contractor's expense.

- (16) **Development of JMF3.** Evaluate the test results from Lot 1, determine the optimum mixture proportions, and submit as JMF3 for use in Lot 2.
- (17) **JMF Adjustments.** If necessary, adjust the JMF before beginning a new lot. The adjusted JMF must:
 - be provided to the Engineer in writing before the start of a new lot,
 - be numbered in sequence to the previous JMF,
 - meet the master gradation limits shown in Table 6, and
 - be within the operational tolerances of JMF2 listed in Table 9.
- (18) **Requesting Referee Testing.** If needed, use referee testing in accordance with Section 346.4.I.1, "Referee Testing," to resolve testing differences with the Engineer.

Table 9
Operational Tolerances

Description	Test Method	Allowable Difference from Current JMF Target	Allowable Difference Between Contractor and Engineer ¹
Individual % retained for #8 sieve and larger	Tex-200-F or Tex-236-F	±5.0 ²	±5.0
Individual % retained for sieves smaller than #8 and larger than #200		±3.0 ²	±3.0
% passing the #200 sieve		±2.0 ²	±1.6
Binder content, %	Tex-236-F	±0.3 ³	±0.3
Laboratory-molded density, %	Tex-207-F	±1.0	±0.5
In-Place air voids, %		N/A	±1.0
Laboratory-molded bulk specific gravity		N/A	±0.020
VMA, % Min		Note 4	Note 4
Theoretical maximum specific (Rice) gravity	Tex-227-F	N/A	±0.020
Drain-down	Tex-235-F	Note 4	Note 4

1. Contractor may request referee testing only when values exceed these tolerances.
2. When within these tolerances, mixture production gradations may fall outside the master grading limits; however, the % passing the #200 will be considered out of tolerance when outside the master grading limits.
3. Tolerance between JMF1 and JMF2 may exceed ±0.3%.
4. Test and verify that Table 6 requirements are met.

b. Engineer's Responsibilities.

- (1) **Gyratory Compactor.** The Engineer will use a Department SGC, calibrated according to Tex-241-F, to mold samples for laboratory mixture design verification. For molding trial batch and production specimens, the Engineer will use the Contractor-provided SGC at the field laboratory or provide and use a Department SGC at an alternate location. The Engineer will make the Contractor-provided SGC in the Department field laboratory available to the Contractor for molding verification samples.
- (2) **Conditional Approval of JMF1.** Within 2 working days of receiving the mixture design report (JMF1) and all required materials and Contractor-provided Hamburg Wheel test results, the Engineer will review the Contractor's mix design report and verify conformance with all aggregates, asphalt, additives, and mixture specifications. The Engineer may perform tests to verify the aggregates meet the requirements listed in Table 1. The Engineer will grant the Contractor conditional

approval of JMF1 if the information provided on the paper copy of JMF1 indicates the Contractor's mixture design meets the specifications. When the Contractor does not provide Hamburg Wheel test results with laboratory mixture design, a total of 10 working days is allowed for conditional approval of JMF1. Full approval of JMF1 will be based on the Engineer's test results on mixture from the trial batch.

- (3) **Hamburg Wheel Testing of JMF1.** If the Contractor requests the option to have the Department perform the Hamburg Wheel test on the laboratory mixture, the Engineer will mold samples in accordance with Tex-242-F to verify compliance with the Hamburg Wheel test requirement in Table 7.
- (4) **Authorizing Trial Batch.** After conditionally approving JMF1, which will include either Contractor- or Department-supplied Hamburg Wheel test results, the Engineer will authorize the Contractor to produce a trial batch.
- (5) **Ignition Oven Correction Factors.** The Engineer will use the split samples provided by the Contractor to determine the aggregate and asphalt correction factors for the ignition oven in accordance with Tex-236-F.
- (6) **Testing the Trial Batch.** Within 1 full working day, the Engineer will sample and test the trial batch to ensure that the gradation, asphalt content, laboratory-molded density, and VMA meet the requirements listed in Table 9. If the Contractor requests the option to have the Department perform the Hamburg Wheel test on the trial batch mixture, the Engineer will mold samples in accordance with Tex-242-F to verify compliance with the Hamburg Wheel test requirement in Table 7.

The Engineer will have the option to perform the following tests on the trial batch:

- Tex-226-F to verify that the indirect tensile strength meets the requirement shown in Table 7,
- Tex-461-A to determine the need for additional magnesium sulfate soundness testing, and
- Tex-530-C to retain and use for comparison purposes during production.

- (7) **Full Approval of JMF1.** The Engineer will grant full approval of JMF1 and authorize the Contractor to proceed with developing JMF2 if the Engineer's results for gradation, asphalt content, laboratory-molded density, and VMA confirm that the trial batch meets the requirements in Table 9.

The Engineer will notify the Contractor that an additional trial batch is required if the trial batch does not meet the requirements in Table 9.

- (8) **Approval of JMF2.** The Engineer will approve JMF2 within 1 working day if it meets the master grading limits shown in Table 6 and is within the operational tolerances of JMF1 listed in Table 9.
- (9) **Approval of Lot 1 Production.** The Engineer will authorize the Contractor to proceed with Lot 1 production as soon as a passing result is achieved from the Department's or an approved laboratory's Hamburg Wheel test on the trial batch. As an option, the Contractor may at their own risk, proceed with Lot 1 production without the results from the Hamburg Wheel test on the trial batch.

If the Department's or Department-approved laboratory's sample from the trial batch fails the Hamburg Wheel test, the Engineer will suspend production until further Hamburg Wheel tests meet the specified values. The Engineer may require up to the entire subplot of any mixture failing the Hamburg Wheel test to be removed and replaced at the Contractor's expense.

- (10) **Approval of JMF3.** The Engineer will approve JMF3 within 1 working day if it meets the master grading limits shown in Table 6 and is within the operational tolerances of JMF2 listed in Table 9.

- E. Production Operations.** Perform a new trial batch when the plant or plant location is changed. Take corrective action and receive approval to proceed after any production suspension for noncompliance to the specification.
- 1. Storage and Heating of Materials.** Do not heat the asphalt binder above the temperatures specified in Item 300, "Asphalts, Oils, and Emulsions" or outside the manufacturer's recommended values.

346.4 to 346.4

On a daily basis, provide the Engineer with the records of asphalt binder and hot-mix asphalt discharge temperatures in accordance with Item 320, "Equipment for Hot-Mix Asphalt Materials."

Unless otherwise approved, do not store mixture for a period long enough to affect the quality of the mixture, nor in any case longer than 12 hr.

2. **Mixing and Discharge of Materials.** Notify the Engineer of the target discharge temperature and produce the mixture within 25°F of the target. Monitor the temperature of the material in the truck before shipping to ensure that it does not exceed 350°F. The Department will not pay for or allow placement of any mixture produced at more than 350°F.

Control the mixing time and temperature so that substantially all moisture is removed from the mixture before discharging from the plant. If requested, determine the moisture content by oven-drying in accordance with Tex-212-F, Part II, and verify that the mixture contains no more than 0.2% of moisture by weight. Obtain the sample immediately after discharging the mixture into the truck, and perform the test promptly.

- F. **Hauling Operations.** Before use, clean all truck beds to ensure mixture is not contaminated. When a release agent is necessary, use a release agent on the approved list maintained by the Construction Division to coat the inside bed of the truck.
- G. **Placement Operations.** Prepare the surface by removing raised pavement markers and objectionable material such as moisture, dirt, sand, leaves, and other loose impediments from the surface before placing mixture. Remove vegetation from pavement edges. Place the mixture to meet the typical section requirements and produce a smooth, finished surface with a uniform appearance and texture. Offset longitudinal joints of successive courses of hot mix by at least 6 in. Place mixture so longitudinal joints on the surface course coincide with lane lines, or as directed. Ensure that all finished surfaces will drain properly. Place mixture within the compacted lift thickness shown in Table 10 unless otherwise shown on the plans or allowed.

Table 10
Compacted Lift Thickness and Required Core Height

Mixture Type	Compacted Lift Thickness		Minimum Untrimmed Core Height (in.) Eligible for Testing
	Minimum (in.)	Maximum (in.)	
SMA-C	2.25	4.00	2.00
SMA-D	1.50	3.00	1.25
SMA-F	1.25	2.50	1.25
SMAR-C	2.00	4.00	1.75
SMAR-F	1.50	3.00	1.25

1. **Weather Conditions.** Place mixture when the roadway surface temperature is 70°F or higher unless otherwise approved. Measure the roadway surface temperature with a handheld infrared thermometer. Unless otherwise shown on the plans, place mixtures only when weather conditions and moisture conditions of the roadway surface are suitable in the opinion of the Engineer.
2. **Tack Coat.** Clean the surface before placing the tack coat. Unless otherwise approved, apply tack coat uniformly at the rate directed by the Engineer. The Engineer will set the rate between 0.04 and 0.10 gal. of residual asphalt per square yard of surface area. Apply a thin, uniform tack coat to all contact surfaces of curbs, structures, and all joints. Prevent splattering of tack coat when placed adjacent to curb, gutter, and structures. Roll the tack coat with a pneumatic-tire roller when directed. The Engineer may use Tex-243-F to verify that the tack coat has adequate adhesive properties. The Engineer may suspend paving operations until there is adequate adhesion.
3. **Lay-Down Operations.** Use the guidelines in Table 11 to establish the temperature of mixture delivered to the paver. Record the information on Department QC/QA forms and submit the forms to the Engineer.
 - a. **Thermal Profile.** For each subplot, obtain a thermal profile using Tex-244-F. The Engineer may reduce the testing frequency based on a satisfactory test history. The Engineer may also obtain as many thermal profiles as deemed necessary. If the temperature differential is greater than 25°F, the area will be deemed as having thermal segregation. Evaluate areas with thermal segregation by performing a density profile in accordance with Section 346.4.I.3.c(2), “Segregation (Density Profile).” Take corrective action to

eliminate areas that have thermal segregation. Unless otherwise directed, suspend operations if the maximum temperature differential exceeds 50°F. Resume operations when the Engineer determines that subsequent production will meet the specifications.

- b. **Windrow Operations.** When hot mix is placed in windrows, operate windrow pickup equipment so that substantially all the mixture deposited on the roadbed is picked up and loaded into the paver.

Table 11
Suggested Minimum Mixture Placement Temperature

High-Temperature Binder Grade	Minimum Placement Temperature (Before Entering Paver)
PG 76 and A-R	280°F
PG 82 or higher	290°F

- H. **Compaction.** Uniformly compact the pavement to the density requirements of the specification. Use the control strip method given in Tex-207-F, Part IV, to establish the rolling pattern. Do not use pneumatic-tire rollers if excessive pickup of fines by roller tires occurs. Unless otherwise directed, use only water or an approved release agent on rollers, tamps, and other compaction equipment.

Where specific air void requirements are waived, furnish and operate compaction equipment as approved. Use tamps to thoroughly compact the edges of the pavement along curbs, headers, and similar structures and in locations that will not allow thorough compaction with rollers. The Engineer may require rolling with a trench roller on widened areas, in trenches, and in other limited areas.

Allow the compacted pavement to cool to 160°F or lower before opening to traffic unless otherwise directed. When directed, sprinkle the finished mat with water or limewater to expedite opening the roadway to traffic.

- I. **Acceptance Plan.** Sample and test the hot mix on a lot and subplot basis. If the production pay factor for 3 consecutive lots or the placement pay factor for 3 consecutive lots is below 1.000, suspend production until test results or other information indicate, to the satisfaction of the Engineer, that the next material produced or placed will meet the specified values. Pay adjustments for the material will be in accordance with Article 346.6, "Payment."

1. **Referee Testing.** The Construction Division is the referee laboratory. The Contractor may request referee testing if a “remove and replace” condition is determined based on the Engineer’s test results, or if the differences between Contractor and Engineer test results exceed the maximum allowable difference shown in Table 9 and the differences cannot be resolved. Make the request within 5 working days after receiving test results and cores from the Engineer. Referee tests will be performed only on the subplot in question and only for the particular test in question. Allow 10 working days from the time the samples are received at the referee laboratory for test results to be reported. The Department may require the Contractor to reimburse the Department for referee tests if more than 3 referee tests per project are required and the Engineer’s test results are closer than the Contractor’s test results to the referee test results.

The Construction Division will determine the laboratory-molded density based on the molded specific gravity and the maximum theoretical specific gravity of the referee sample. The In-Place air voids will be determined based on the bulk specific gravity of the cores, as determined by the referee laboratory, and the Engineer’s average maximum theoretical specific gravity for the lot. With the exception of remove and replace conditions, referee test results are final and will establish pay adjustment factors for the subplot in question. Sublots subject to be removed and replaced will be further evaluated in accordance with Article 346.6, “Payment.”

2. **Production Acceptance.**

- a. **Production Lot.** A production lot consists of 4 equal sublots. Lot 1 will be 1,000 tons. The Engineer will select subsequent lot sizes based on the anticipated daily production. The lot size will be at least 1,000 tons, but no greater than 4,000 tons. The Engineer may change the lot size before the Contractor begins any lot.

- (1) **Small Quantity Production.** When the anticipated daily production is less than 500 tons or the total production for the project is less than 5,000 tons, the Engineer may waive all quality control and quality assurance (QC/QA) sampling and testing requirements. If the Engineer waives QC/QA sampling and testing, both production and placement pay factors will be 1.000. However, the Engineer will retain the right to perform random

acceptance tests for production and placement and may reject objectionable materials and workmanship.

When the Engineer waives all QC/QA sampling and testing requirements:

- produce, haul, place and compact the mixture as directed by the Engineer;
- control mixture production to yield a laboratory-molded density of $96.0\% \pm 1.0\%$ for SMA mixtures and $97.0\% \pm 1.0\%$ for SMAR mixtures if tested by the Engineer; and
- compact the mixture to yield In-Place air voids that are greater than or equal to 2.7% and less than or equal to 8.0% as tested by the Engineer.

- (2) **Incomplete Production Lots.** If a lot is begun but cannot be completed, such as on the last day of production or in other circumstances deemed appropriate, the Engineer may close the lot. Adjust the payment for the incomplete lot in accordance with Section 346.6.A, "Production Pay Adjustment Factors."

b. Production Sampling.

- (1) **Mixture Sampling.** At the beginning of the project, the Engineer will select random numbers for all production sublots. Determine sample locations in accordance with Tex-225-F.

Obtain hot mix samples from trucks at the plant in accordance with Tex-222-F. For each subplot, take 1 sample at the location randomly selected. For each lot, the Engineer will randomly select and test a "blind" sample from at least 1 subplot. The location of the Engineer's "blind" sample will not be disclosed to the Contractor. The Engineer will use the Contractor's split sample for sublots not sampled by the Engineer.

The sampler will split each sample into 3 equal portions in accordance with Tex-200-F, and label these portions as "Contractor," "Engineer," and "Referee." Deliver the samples to the appropriate party's laboratory. Deliver referee samples to the Engineer. Discard unused samples after accepting pay adjustment factors for that lot.

(2) Asphalt Binder Sampling. Obtain a 1-qt. (1-gal. for A-R binder) sample of the asphalt binder for each subplot of mixture produced. Obtain the sample at approximately the same time the mixture random sample is obtained. Sample from a port located immediately upstream from the mixing drum or pug mill. Take the sample in accordance with the pipeline sampling procedure given in Tex-500-C, Part II. Label the can with the corresponding lot and subplot numbers, and deliver the sample to the Engineer.

The Engineer may also obtain independent samples. If the Engineer chooses to obtain an independent asphalt binder sample, the Engineer will split a sample of the asphalt binder with the Contractor. The Engineer will test at least 1 asphalt binder sample per project to verify compliance with Item 300, "Asphalts, Oils, and Emulsions."

c. Production Testing. The Contractor and Engineer must perform production tests in accordance with Table 12. The Contractor has the option to verify the Engineer's test results on split samples provided by the Engineer. Determine compliance with operational tolerances listed in Table 9 for all sublots.

At any time during production the Engineer may require the Contractor to verify the following based on quantities used:

- lime content (within $\pm 0.1\%$ of JMF), when PG binder is specified;
- fiber content (within $\pm 0.03\%$ of JMF), when PG binder is specified; and
- CRM content (within $\pm 1.5\%$ of JMF), when A-R binder is specified.

When A-R binder is specified, maintain the in-line measuring device to verify the A-R binder viscosity of at least 2,500 centipoise at 350°F unless otherwise approved.

If the aggregate mineralogy is such that Tex-236-F does not yield reliable results, the Engineer may allow alternate methods for determining the asphalt content and aggregate gradation. Unless otherwise allowed, the Engineer will require the Contractor to provide evidence that results from Tex-236-F are not reliable before permitting an alternate

method. If an alternate test method is allowed, use the applicable test procedure as directed.

**Table 12
Production and Placement Testing Frequency**

Description	Test Method	Minimum Contractor Testing Frequency	Minimum Engineer Testing Frequency
Individual % retained for #8 sieve and larger	Tex-200-F or Tex-236-F	1 per subplot	1 per 12 sublots
Individual % retained for sieves smaller than #8 and larger than #200			
% passing the #200 sieve			
Laboratory-molded density	Tex-207-F	N/A	1 per subplot
VMA			
Laboratory-molded bulk specific gravity			
In-Place air voids			
Segregation (density profile)	Tex-207-F, Part V	1 per subplot	1 per project
Longitudinal joint density	Tex-207-F, Part VII		
Moisture content	Tex-212-F, Part II	When directed	
Theoretical maximum specific (Rice) gravity	Tex-227-F	N/A	1 per subplot
Drain-down	Tex-235-F	1 per subplot	1 per 12 sublots
Asphalt content	Tex-236-F		1 per lot
Hamburg Wheel test	Tex-242-F	N/A	1 per project
Thermal profile	Tex-244-F	1 per subplot	
Asphalt binder sampling ¹	Tex-500-C	1 per subplot (sample only)	
Boil test ¹	Tex-530-C	1 per lot	

1. The Engineer may reduce or waive the sampling and testing requirements based on a satisfactory test history.

d. Operational Tolerances. Control the production process within the operational tolerances listed in Table 9. When production is suspended, the Engineer will allow production to resume when test results or other information indicates the next mixture produced will be within the operational tolerances.

(1) Gradation. Unless otherwise directed, suspend production when either the Contractor’s or the Engineer’s test results for gradation exceed the operational tolerances for 3 consecutive sublots on the same sieve or 4

consecutive sublots on any sieve. The consecutive sublots may be from more than 1 lot.

- (2) **Asphalt Content.** No production or placement bonus will be paid for any lot that has 2 or more sublots within a lot that are out of operational tolerance for asphalt content based on either the Contractor's or the Engineer's test results. Suspend production and shipment of mixture if the asphalt content deviates from the current JMF by more than 0.5% for any subplot.
- (3) **Fibers.** Suspend production if fiber content varies from the design target value by more than 10% on 2 consecutive tests.
- (4) **Hamburg Wheel Test.** The Engineer may perform a Hamburg Wheel test at any time during production including when the boil test indicates a change in quality from the materials submitted for JMF1. In addition to testing production samples, the Engineer may obtain cores and perform Hamburg Wheel tests on any area of the roadway where rutting is observed. When the production or core samples fail the Hamburg Wheel test criteria in Table 8, suspend production until further Hamburg Wheel tests meet the specified values. Core samples if taken will be obtained from the center of the finished mat or other areas excluding the vehicle wheel path. The Engineer may require up to the entire subplot of any mixture failing the Hamburg Wheel test to be removed and replaced at the Contractor's expense.

If the Department's or Department-approved laboratory's Hamburg Wheel test results in a "remove and replace" condition, the Contractor may request the Department confirm the results by retesting the failing material. The Construction Division will perform the Hamburg Wheel tests and determine the final disposition of the material in question based on the Department's test results.

- e. **Individual Loads of Hot Mix.** The Engineer can reject individual truckloads of hot mix. When a load of hot mix is rejected for reasons other than temperature, the Contractor may request that the rejected load be tested. Make this request within 4 hr. of rejection. The Engineer will sample and test the mixture. If test results are within the operational tolerances

shown in Table 9, payment will be made for the load. If test results are not within operational tolerances, no payment will be made for the load and the Engineer may require removal.

3. Placement Acceptance.

- a. Placement Lot.** A placement lot consists of 4 placement sublots. A placement subplot consists of the area placed during a production subplot.

 - (1) Lot 1 Placement.** Placement bonuses for Lot 1 will be in accordance with Section 346.6.B, “Placement Pay Adjustment Factors.” However, no placement penalty will be assessed for any subplot placed in Lot 1, when the In-Place air voids are greater than or equal to 2.7% and less than or equal to 8.0%. Remove and replace any subplot with In-Place air voids less than 2.7% or greater than 8.0%.
 - (2) Incomplete Placement Lots.** An incomplete placement lot consists of the area placed as described in Section 346.4.I.2.a(2), “Incomplete Production Lot,” excluding miscellaneous areas as defined in Section 346.4.I.3.a(4), “Miscellaneous Areas.” Placement sampling is required if the random sample plan for production resulted in a sample being obtained from an incomplete production subplot.
 - (3) Shoulders and Ramps.** Shoulders and ramps are subject to In-Place air void determination and pay adjustments, unless otherwise shown on the plans.
 - (4) Miscellaneous Areas.** Miscellaneous areas include areas that are not generally subject to primary traffic, such as driveways, mailbox turnouts, crossovers, gores, spot level-up areas, and other similar areas. Miscellaneous areas also include level-ups and thin overlays if the layer thickness designated on the plans is less than the compacted lift thickness shown in Table 10. Miscellaneous areas are not eligible for random placement sampling locations, and will receive a 1.000 placement pay factor. Compact areas that are not subject to In-Place air void determination in accordance with Section 346.4.H, “Compaction.”

- b. Placement Sampling.** At the beginning of the project, the Engineer will select random numbers for all placement sublots. The Engineer will provide the Contractor with the placement random numbers immediately after the subplot is completed. Mark the roadway location at the completion of each subplot and record the station number. Determine 1 random sample location for each placement subplot in accordance with Tex-225-F. If the randomly generated sample location is within 2 ft. of a joint or pavement edge, adjust the location by no more than necessary to achieve a 2-ft. clearance.

Shoulders and ramps are always eligible for selection as a random sample location. However, if a random sample location falls on a shoulder or ramp that is designated on the plans as not subject to In-Place air void testing, cores will not be taken for the subplot and a 1.000 pay factor will be assigned to that subplot.

Unless otherwise determined, the Engineer will witness the coring operation and measurement of the core thickness. Unless otherwise approved, obtain the cores within 1 working day of the time the placement subplot is completed. Obtain two 6-in.-diameter cores side-by-side from within 1 ft. of the random location provided for the placement subplot. Mark the cores for identification. Visually inspect each core and verify that the current paving layer is bonded to the underlying layer. If an adequate bond does not exist between the current and underlying layer, take corrective action to insure that an adequate bond will be achieved during subsequent placement operations.

Immediately after obtaining the cores, dry the core holes and tack the sides and bottom. Fill the hole with the same type of mixture and properly compact the mixture. Repair core holes with other methods when approved.

If the core heights exceed the minimum untrimmed values listed in Table 10, trim and deliver the cores to the Engineer within 1 working day following placement operations unless otherwise approved.

If the core height before trimming is less than the minimum untrimmed value shown in Table 10, decide whether or not to include the pair of cores in the air void determination for that

sublot. If the cores are to be included in air void determination, trim the cores before delivering to the Engineer. If the cores will not be included in air void determination, deliver untrimmed cores to the Engineer. The placement pay factor for the sublot will be 1.000 if cores will not be included in air void determination.

- c. **Placement Testing.** Perform placement tests in accordance with Table 12. After the Engineer returns the cores, the Contractor has the option to test the cores to verify the Engineer's test results for in-place air voids. Re-dry the cores to constant weight before testing. The allowable differences between the Contractor's and Engineer's test results are listed in Table 9.

- (1) **In-Place Air Voids.** The Engineer will measure in-place air voids in accordance with Tex-207-F and Tex-227-F. Before drying to a constant weight, cores may be predried using a Corelok or similar vacuum device to remove excess moisture. The Engineer will average the values obtained for all sublots in the production lot to determine the theoretical maximum specific gravity. The Engineer will use the average air void content of the 2 cores to calculate a placement pay adjustment factor.

The Engineer will use paraffin coating or vacuum methods to seal the core if required by Tex-207-F. The Engineer will use the test results from the unsealed core to determine the placement pay adjustment factor if the sealed core yields a higher specific gravity than the unsealed core. After determining the in-place air void content, the Engineer will return the cores and provide test results to the Contractor.

- (2) **Segregation (Density Profile).** Test for segregation using density profiles in accordance with Tex-207-F, Part V. Provide the Engineer with the results of the density profiles as they are completed. Areas defined in Section 346.4.I.3.a(4), "Miscellaneous Areas," are not subject to density profile testing.

Unless otherwise approved, perform a density profile every time the screed stops, on areas that are identified by either the Contractor or the Engineer as having thermal segregation, and on any visibly segregated areas. If the

screed does not stop, and there are no visibly segregated areas or areas that are identified as having thermal segregation, perform a minimum of 1 profile per subplot. Reduce the test frequency to a minimum of 1 profile per lot if 4 consecutive profiles are within established tolerances. Continue testing at a minimum frequency of 1 per lot unless a profile fails, at which point resume testing at a minimum frequency of 1 per subplot. The Engineer may further reduce the testing frequency based on a consistent pattern of satisfactory results.

The density profile is considered failing if it exceeds the tolerances in Table 13. No production or placement bonus will be paid for any subplot that contains a failing density profile. The Engineer may make as many independent density profile verifications as deemed necessary. The Engineer's density profile results will be used when available.

Investigate density profile failures and take corrective actions during production and placement to eliminate the segregation. Suspend production if 2 consecutive density profiles fail, unless otherwise approved. Resume production after the Engineer approves changes to production or placement methods.

Table 13
Segregation (Density Profile) Acceptance Criteria

Mixture Type	Maximum Allowable Density Range (Highest to Lowest)	Maximum Allowable Density Range (Average to Lowest)
SMA-C & SMAR-C	8.0 pcf	5.0 pcf
SMA-D, SMA-F & SMA-F	6.0 pcf	3.0 pcf

(3) Longitudinal Joint Density.

- (a) Informational Tests.** While establishing the rolling pattern, perform joint density evaluations and verify that the joint density is no more than 3.0 pcf below the density taken at or near the center of the mat. Adjust the rolling pattern if needed to achieve the desired joint density. Perform additional joint density evaluations at least once per subplot unless otherwise directed.

- (b) **Record Tests.** For each subplot, perform a joint density evaluation at each pavement edge that is or will become a longitudinal joint. Determine the joint density in accordance with Tex-207-F, Part VII. Record the joint density information and submit results, on Department forms, to the Engineer. The evaluation is considered failing if the joint density is more than 3.0 pcf below the density taken at the core random sample location and the correlated joint density is less than 90.0%. The Engineer may make independent joint density verifications at the random sample locations. The Engineer's joint density test results will be used when available.

Investigate joint density failures and take corrective actions during production and placement to improve the joint density. Suspend production if 2 consecutive evaluations fail unless otherwise approved. Resume production after the Engineer approves changes to production or placement methods.

- (4) **Recovered Asphalt DSR.** The Engineer may take production samples or cores from suspect areas of the project to determine recovered asphalt properties. Asphalt binders with an aging ratio greater than 3.5 do not meet the requirements for recovered asphalt properties and may be deemed defective when tested and evaluated by the Construction Division. The aging ratio is the dynamic shear rheometer (DSR) value of the extracted binder divided by the DSR value of the original unaged binder (including RAP binder). DSR values are obtained according to AASHTO T 315 at the specified high temperature PG of the asphalt. The binder from RAP will be included proportionally as part of the original unaged binder. The Engineer may require removal and replacement of the defective material at the Contractor's expense. The asphalt binder will be recovered for testing from production samples or cores using Tex-211-F.
- (5) **Irregularities.** Immediately take appropriate corrective action if surface irregularities, including but not limited to segregation, rutting, raveling, flushing, fat spots, mat slippage, color, texture, roller marks, tears, gouges,

streaks, or uncoated aggregate particles are detected. The Engineer may allow placement to continue for at most 1 day of production while taking appropriate action. If the problem still exists after that day, suspend paving until the problem is corrected to the satisfaction of the Engineer.

At the expense of the Contractor and to the satisfaction of the Engineer, remove and replace any mixture that does not bond to the existing pavement or has other surface irregularities identified above.

4. **Ride Quality.** Unless otherwise shown on the plans, measure ride quality in accordance with Item 585, "Ride Quality for Pavement Surfaces."

346.5. Measurement. Hot mix will be measured by the ton of composite hot mix. The composite hot mix is the asphalt, aggregate, and additives. Measure on scales in accordance with Item 520, "Weighing and Measuring Equipment."

346.6. Payment. The work performed and materials furnished in accordance with this Item and measured as provided under Article 346.5, "Measurement," will be paid for at the unit bid price for "Stone Matrix Asphalt," of the mixture type, surface aggregate classification, and binder specified. Pay adjustments for bonuses and penalties will be applied as determined in this Item. These prices are full compensation for surface preparation, materials including tack coat, placement, equipment, labor, tools, and incidentals.

Trial batches will not be paid for unless they are included in pavement work approved by the Department.

Pay adjustment for ride quality will be determined in accordance with Item 585, "Ride Quality for Pavement Surfaces."

- A. **Production Pay Adjustment Factors.** The production pay adjustment factor is based on the laboratory-molded density using the Engineer's test results. A pay adjustment factor will be determined from Table 14 for each subplot using the deviation from the target laboratory-molded density defined in Table 7. The production pay adjustment factor for completed lots will be the average of the pay adjustment factors for the 4 sublots sampled within that lot.

Table 14
Production Pay Adjustment Factors for Laboratory-Molded Density

Absolute Deviation from Target Laboratory-Molded Density	Production Pay Adjustment Factor
0.0	1.100
0.1	1.100
0.2	1.100
0.3	1.086
0.4	1.075
0.5	1.063
0.6	1.050
0.7	1.038
0.8	1.025
0.9	1.013
1.0	1.000
1.1	0.900
1.2	0.800
1.3	0.700
> 1.3	Remove and replace

1. **Incomplete Production Lots.** Production pay adjustments for incomplete lots, described under Section 346.4.I.2.a(2), “Incomplete Production Lots,” will be calculated using the average production pay factors from all sublots sampled. A production pay factor of 1.000 will be assigned to any lot when the random sampling plan did not result in collection of any samples.
 2. **Production Sublots Subject to Removal and Replacement.** If after referee testing, the laboratory-molded density for any subplot results in a “remove and replace” condition as listed in Table 14, the Engineer may require removal and replacement, or may allow the subplot to be left in place without payment. Replacement material meeting the requirements of this Item will be paid for in accordance with this Article.
- B. Placement Pay Adjustment Factors.** The placement pay adjustment factor is based on in-place air voids using the Engineer’s test results. A pay adjustment factor will be determined from Table 15 for each subplot that requires in-place air void measurement. A placement pay adjustment factor of 1.000 will be assigned to the entire subplot when the random sample location falls in an area on a ramp or shoulder not subject to in-place air void testing. A placement pay adjustment factor of 1.000 will be assigned to quantities placed in miscellaneous areas as described in Section 346.4.I.3.a(4), “Miscellaneous Areas.” The

placement pay adjustment factor for completed lots will be the average of the placement pay adjustment factors for the 4 sublots within that lot.

Table 15
Placement Pay Adjustment Factors for In-Place Air Voids

In-Place Air Voids	Placement Pay Adjustment Factor	In-Place Air Voids	Placement Pay Adjustment Factor
< 2.7	Remove and Replace	5.4	1.030
2.7	0.700	5.5	1.025
2.8	0.740	5.6	1.020
2.9	0.780	5.7	1.015
3.0	0.820	5.8	1.010
3.1	0.860	5.9	1.005
3.2	0.900	6.0	1.000
3.3	0.940	6.1	0.985
3.4	0.980	6.2	0.970
3.5	1.020	6.3	0.955
3.6	1.060	6.4	0.940
3.7	1.100	6.5	0.925
3.8	1.100	6.6	0.910
3.9	1.100	6.7	0.895
4.0	1.100	6.8	0.880
4.1	1.095	6.9	0.865
4.2	1.090	7.0	0.850
4.3	1.085	7.1	0.835
4.4	1.080	7.2	0.820
4.5	1.075	7.3	0.805
4.6	1.070	7.4	0.790
4.7	1.065	7.5	0.775
4.8	1.060	7.6	0.760
4.9	1.055	7.7	0.745
5.0	1.050	7.8	0.730
5.1	1.045	7.9	0.715
5.2	1.040	8.0	0.700
5.3	1.035	> 8.0	Remove and Replace

- Incomplete Placement Lots.** Pay adjustments for incomplete placement lots described under Section 346.4.I.3.a(2), “Incomplete Placement Lots,” will be calculated using the average of the placement pay factors from all sublots sampled and sublots where the random location falls in an area on a ramp or shoulder not eligible for testing. A placement pay adjustment factor of 1.000 will be assigned to any lot when the random sampling plan did not result in collection of any samples.

350.1 to 350.2

- 2. Placement Sublots Subject to Removal and Replacement.** If after referee testing the placement pay adjustment factor for any subplot results in a “remove and replace” condition as listed in Table 15, the Engineer will choose the location of 2 cores to be taken within 3 ft. of the original failing core location. The Contractor will obtain the cores in the presence of the Engineer. The Engineer will submit the cores to the Materials and Pavements Section of the Construction Division where they will be tested for bulk specific gravity within 10 working days of receipt. The average bulk specific gravity of the cores will be divided by the Engineer’s average maximum theoretical specific gravity for that lot to determine the new pay adjustment factor of the subplot in question. If the new pay adjustment factor is 0.700 or greater, then the new pay adjustment factor will apply to that subplot. If the new pay adjustment factor is less than 0.700, no payment will be made for the subplot. Remove and replace the failing subplot. Replacement material must meet the requirements of this specification with payment made accordingly.

- C. Total Adjustment Pay Calculation.** Total adjustment pay (TAP) will be based on the applicable pay adjustment factors for production and placement of each lot.

$$TAP = (A + B)/2$$

where:

A = Bid price \times production lot quantity \times average pay adjustment factor for the production lot

B = Bid price \times placement lot quantity \times average pay adjustment factor for the placement lot + (bid price \times miscellaneous quantities \times 1.000).

ITEM 350

MICROSURFACING

350.1. Description. Furnish and place a microsurfacing system consisting of a mixture of cationic polymer-modified asphalt emulsion, mineral aggregate, mineral filler, water, and other additives.

350.2. Materials.

- A. Cationic Polymer-Modified Asphalt Emulsion.** Provide CSS-1P in accordance with Section 300.2.D, “Emulsified Asphalt.”

- B. Mineral Aggregates.** Provide a crushed aggregate from a single source meeting the requirements of Table 1 and Table 2. Unless otherwise shown on the plans, furnish aggregate with a minimum “B” surface classification. Include the amount of mineral filler added to the mix in determining the total minus No. 200 aggregate fraction.

Table 1
Aggregate Gradation Requirements
Tex-200-F, Part II (Washed)

Sieve Size	Cumulative % Retained
1/2 in.	0
3/8 in.	0–1
#4	6–14
#8	35–55
#16	54–75
#30	65–85
#50	75–90
#100	82–93
#200	85–95

Table 2
Aggregate Quality Requirements

Property	Test Method	Requirements
Magnesium sulfate soundness, %, max. ¹	Tex-411-A	30
Sand equivalent value, %, min.	Tex-203-F	70

1. Use design gradation for the soundness test.

- C. Mineral Filler.** Provide a mineral filler that is free of lumps and foreign matter consisting of non-air-entrained cement meeting the requirements of DMS-4600, “Hydraulic Cement,” or hydrated lime meeting the requirements of DMS-6350, “Lime and Lime Slurry.”
- D. Water.** Provide water that is potable and free of harmful soluble salts.
- E. Other Additives.** Use approved additives as recommended by the emulsion manufacturer in the emulsion mix or in any of the component materials when necessary to adjust mix time in the field.
- F. Job-Mix Formula (JMF).** Provide a mix design conforming to the proportions shown in Table 3 and meeting the requirements shown in Table 4. The mix design is subject to verification using laboratory-produced mixes or trial batch mix before approval.

350.3 to 350.3

Table 3
JMF Proportions

Material	Proportion
Residual asphalt	6.0 to 9.0% by wt. of dry aggregate
Mineral filler (hydraulic cement or hydrated lime)	0.5 to 3.0% by wt. of dry aggregate
Field control additive	As required to provide control of break and cure
Water	As required to provide proper consistency

Table 4
JMF Requirements

Property	Test Method	Requirements
Wet track abrasion, g/sq. ft., max. wear value	Tex-240-F, Part IV	75
Gradation (aggregate and mineral filler)	Tex-200-F, Part II (Washed)	Table 1
Mix time, controlled to 120 sec.	Tex-240-F, Part I	Pass

Provide emulsion and aggregate that are compatible so that the mixing process will completely and uniformly coat the aggregate. Design the mix so that the mixture will have sufficient working life to allow for proper placement at the predicted ambient temperature and humidity.

350.3. Equipment. Maintain equipment in good repair and operating condition.

- A. Mixing Machine.** Furnish a self-propelled microsurfacing mixing machine with:
- self-loading devices to promote continuous laying operations;
 - sufficient storage capacity for mixture materials;
 - individual volume or weight controls that will proportion each material to be added to the mix;
 - continuous flow mixing with a revolving multi-blade mixer capable of discharging the mixture on a continuous flow basis;
 - opposite side driving stations;
 - full hydrostatic control of the forward and reverse speed during operation;
 - a water pressure system and nozzle-type spray bar immediately ahead of the spreader box and capable of spraying the roadway for the width of the spreader box;
 - a mechanical-type spreader box equipped with paddles or other devices capable of agitating and spreading the materials throughout the box;

- a spreader box with devices capable of providing lateral movement or side shift abilities; and
- a spreader box with a front seal, adjustable rear strike-off, and an adjustable secondary rear strike-off.

Calibrate and properly mark each control device that proportions the individual materials. Equip the aggregate feed with a revolution counter or similar device capable of determining the quantity of aggregate used at all times. Provide a positive-displacement-type emulsion pump with a revolution counter or similar device capable of determining the quantity of emulsion used at all times. Provide an approved mineral filler feeding system capable of uniformly and accurately metering the required material.

- B. Scales.** Scales used for weighing aggregates and emulsion must meet all requirements of Item 520, “Weighing and Measuring Equipment.” The weighing equipment for aggregates may be either a suspended hopper or a belt scale.
- C. Asphalt Storage and Handling Equipment.** When storage tanks are used, furnish a thermometer in each tank to indicate the asphalt temperature continuously. Keep equipment clean and free of leaks. Keep asphalt materials free from contamination.

350.4. Construction.

- A. General.** Produce, transport, and place microsurfacing as specified in this Item or on the plans. Ensure that the finished surface has a uniform texture and the microsurface mat is fully adhered to the underlying pavement.
- B. Temporary Material Storage.**
- 1. Aggregate Storage.** Stockpile materials in a manner that will prevent segregation or contamination. Remix stockpiles with suitable equipment when necessary to eliminate segregation. Use a scalping screen while transferring aggregates to the mixing machine to remove oversize material.
 - 2. Mineral Filler Storage.** Store the mineral filler in a manner that will keep it dry and free from contamination.
 - 3. Asphalt Material Storage.** Keep asphalt materials free from contamination.
- C. Weather Limitations.** Place the material when the atmospheric temperature is at least 50°F and rising and the surface temperature is at least 50°F. Cease placement when the atmospheric temperature is

350.4 to 350.4

below 60°F and falling, when weather is foggy or rainy, or when rain is imminent as determined by the Engineer. Cease placement 24 hr. before forecasted temperatures below 32°F.

- D. Surface Preparation.** Thoroughly clean the surface of all vegetation, loose aggregate, and soil. Remove existing raised pavement markers. When existing surface conditions require, provide a water spray immediately ahead of the spreader box. Apply water at a rate that will dampen the entire surface without any free-flowing water ahead of the spreader box.
- E. Material Transfer.** Minimize construction joints by providing continuous loading of material while placing microsurfacing. Ensure that oversized material has been removed prior to transferring the aggregates to the mixing machine.
- F. Placing.** Spread the mixture uniformly to the lines and grades shown on the plans or as directed by means of a mechanical type spreader box. Shift the spreader box when necessary to maintain proper alignment. Clean the spreader box as necessary to minimize clumps. Set and maintain the spreader box skids to prevent chatter in the finished mat. Prevent loss of material from the spreader box by maintaining contact between the front seal and the road surface. Adjust the rear seal to provide the desired spread. Adjust the secondary strike-off to provide the desired surface texture.
- G. Curing.** Protect the finished mat from traffic until the mix cures and will not be damaged by traffic. Adjust mixture properties according to humidity conditions and ambient air temperatures to allow uniformly moving traffic on completed travel lanes within 1 hr. after placement with no damage to the surface. Protect other locations subject to sharp turning or stopping and starting traffic for longer periods when necessary.
- H. Production Testing.** Provide access to the mixing unit discharge stream for sampling purposes. Produce a microsurfacing mixture that will meet the tolerances specified in Table 5. Remove and replace or use other approved means to address material that does not meet these requirements, at no additional cost.

Table 5
Production Test

Property	Test Method	Requirements
Asphalt content, % by wt.	Tex-236-F ¹ or asphalt meter readings	Design target $\pm 0.5\%$ and within limits of Table 1
Gradation, % retained	Tex-200-F, Part II (washed) ¹	#8 sieve and larger: ± 5 from design gradation. #16 sieve and smaller: ± 3 from design gradation. ²

1. Dried to constant wt. at 230°F $\pm 10^\circ$ F.

2. Material passing #200 sieve including the mineral filler must conform to the limitations of the master gradation shown in Table 1.

- I. Workmanship.** Remove and replace microsurfacing material exhibiting evidence of poor workmanship at no additional cost.
1. **Finished Surface.** Provide a finished surface that has a uniform texture free from excessive scratch marks, tears, or other surface irregularities. Marks, tears, or irregularities are considered excessive if:
 - more than 1 is at least 1/4 in. wide and at least 10 ft. long in any 100 ft. of machine pull,
 - more than 3 are at least 1/2 in. wide and more than 6 in. long in any 100 ft. of machine pull, or
 - any are 1 in. wide or wider and more than 4 in. in length.
 2. **Construction Joints.** Place longitudinal joints on lane lines unless otherwise directed. Provide longitudinal and transverse joints that are uniform and neat in appearance. Provide construction joints that have limited buildup and that have no gaps between applications. Joints with buildup will be considered acceptable if:
 - no more than 1/2 in. vertical space exists between the pavement surface and a 4-ft. straightedge placed perpendicular to the longitudinal joint and
 - no more than 1/4 in. vertical space exists between the pavement surface and a 4-ft. straightedge placed perpendicular to the transverse joint.
 3. **Edges.** Provide an edge along the roadway centerline, lane lines, shoulder, edge of pavement, or curb line that is uniform and neat in appearance. The edge is considered acceptable when:
 - it varies no more than ± 3 in. from a 100-ft. straight line on a tangent section and
 - it varies no more than ± 3 in. from a 100-ft. arc on a curved section.

350.5 to 350.6

- J. Miscellaneous Areas.** Use a single-batch-type lay-down machine or other approved method to place materials on ramps or other short sections. Lightly dampen the surface before placing the mix. Provide 100% coverage that is uniform in appearance and comparable to that produced by the spreader box.
- K. Ruts.** When shown on the plans, fill ruts, utility cuts, and depressions in the existing surface in a separate pass from the final surface. Fill ruts as follows:
- Fill irregular or shallow ruts less than 1/2 in. deep with a full-width scratch coat pass. Use a rigid primary strike-off plate unless otherwise approved.
 - Fill ruts 1/2 in. deep or deeper independently using a rut-filling spreader box that is at least 5 ft. wide. Crown the spreader box to compensate for traffic compaction.
 - Fill ruts deeper than 1-1/2 in. in multiple placements unless otherwise approved.

350.5. Measurement. Microsurfacing will be measured by the ton of the composite microsurfacing mixture. The composite microsurfacing mixture is defined as the asphalt emulsion, aggregate, and mineral filler.

- A. Aggregate.** The quantity of aggregate used in the accepted portion of work will be measured by net ticket weight of each individual load of aggregate based on dry weight of aggregate. Weigh the aggregate at the project stockpile site unless otherwise approved. Use either a suspended hopper scale or a belt scale meeting the requirements of Item 520, "Weighing and Measuring Equipment." The calculated weight of mineral filler based on the accepted portion of work will be used for measurement and included in the total aggregate weight.
- B. Polymer-Modified Asphalt Emulsion.** The quantity of polymer-modified asphalt emulsion in the accepted portion of work will be measured by the ton of material based on the accepted load tickets issued from the manufacturer. At the completion of the project, any unused emulsion will be weighed back and deducted from the accepted asphalt emulsion quantity delivered.

350.6. Payment. The work performed and materials furnished in accordance with this Item and measured as provided under "Measurement" will be paid for at the unit price bid per ton for "Microsurfacing." This price is full compensation for preparing the existing surface (including removing existing raised pavement markers); furnishing, hauling, preparing, and placing materials; and equipment, labor, tools, and incidentals.

ITEM 351

FLEXIBLE PAVEMENT STRUCTURE REPAIR

351.1. Description. Repair localized sections of flexible pavement structure including subgrade, base, and surfacing as shown on the plans.

351.2. Materials. Furnish materials unless otherwise shown on the plans. Provide materials of the type and grade as shown on the plans and in accordance with:

- Item 132, “Embankment”
- Item 204, “Sprinkling”
- Item 247, “Flexible Base”
- Item 260, “Lime Treatment (Road Mixed)”
- Item 263, “Lime Treatment (Plant Mixed)”
- Item 275, “Cement Treatment (Road Mixed)”
- Item 276, “Cement Treatment (Plant Mixed)”
- Item 292, “Asphalt Treatment (Plant Mix)”
- Item 310, “Prime Coat”
- Item 316, “Surface Treatments”
- Item 330, “Limestone Rock Asphalt Pavement”
- Item 334, “Hot-Mix Cold-laid Asphalt Concrete Pavement”
- Item 340, “Hot Mix Asphalt.”

For asphalt concrete materials, Contractor testing and bonus and penalty provisions will be waived unless otherwise shown on the plans.

351.3. Equipment. Furnish equipment in accordance with pertinent Items. Use of a motor grader will be permitted for asphalt concrete pavement unless otherwise shown on the plans.

351.4. Work Methods. Repair using one or more of the following operations as shown on the plans. For Contracts with callout work, begin physical repair within 24 hr. of notification, unless otherwise shown on the plans. Cut neat vertical faces around the perimeter of the work area when removing pavement structure layers. Removed materials are the property of the Contractor unless otherwise shown on the plans. Dispose of removed material in accordance with federal, state, and local regulations. Provide a smooth line and grade conforming to the adjacent pavement.

A. Removing Pavement Structure. If necessary, remove adjacent soil and vegetation to prevent contamination of the repair area, and place it in a windrow. Do not damage adjacent pavement structure during repair

351.4 to 351.4

operations. If subgrade work is required, remove flexible pavement structure layers from work area.

- B. Preparing Subgrade.** Fill holes, ruts, and depressions with approved material. If required, thoroughly wet, reshape, and compact the subgrade as directed.

Where subgrade has failed, remove unstable subgrade material to the depth directed and replace with an approved material.

- C. Mixing and Placing Base Material.** Place, spread, and compact material in accordance with the applicable Item to the required or directed depth. When bituminous material is to remain in pavement structure, pulverize to a maximum dimension of 2-1/2 in. and uniformly mix with existing base to the depth shown on the plans.
- 1. Flexible Base.** Use existing base and add new flexible base as required in accordance with Item 247, "Flexible Base," and details shown on the plans to achieve required section.
 - 2. Lime-Stabilized Base.** Use existing base, add new flexible base, and stabilize with a minimum lime content of 3% by weight of the total mixture. Construct in accordance with Item 260, "Lime Treatment (Road Mixed)," and Item 263, "Lime Treatment (Plant Mixed)," and details shown on the plans to achieve required section.
 - 3. Cement-Stabilized Base.** Use existing base, add flexible base, and stabilize with a minimum cement content of 4% by weight of the total mixture. Construct in accordance with details shown on the plans and Item 275, "Cement Treatment (Road Mixed)," or Item 276, "Cement Treatment (Plant Mixed)," to achieve required section.
 - 4. Asphalt-Stabilized Base.** Place asphalt-stabilized base in accordance with details shown on the plans and Item 292, "Asphalt Treatment (Plant Mix)," or Item 340, "Hot Mix Asphalt," to achieve required section.
 - 5. Limestone Rock Asphalt.** Place in accordance with Item 330, "Limestone Rock Asphalt Pavement," and details shown on the plans to achieve required section.
- D. Curing Base.** Cure in accordance with the appropriate Item unless otherwise directed or approved. Maintain completed base sections until surfacing.

- E. Surfacing.** Apply surfacing with materials as shown on the plans to the completed base section.
- 1. Prime Coat.** Protect the compacted, finished, and cured flexible, lime-stabilized, or cement-stabilized base mixtures with a prime coat of the type and grade shown on the plans. Apply the prime coat at the rate shown on the plans.
 - 2. Surface Treatments.** Apply surface treatment with the type and grade of asphalt and aggregate as shown on the plans in accordance with Item 316, "Surface Treatments."
 - 3. Asphalt Concrete Pavement.** Apply tack coat of the type and grade and at the rate shown on the plans unless otherwise directed. Construct in accordance with Item 330, "Limestone Rock Asphalt Pavement," Item 334, "Hot-Mix Cold-laid Asphalt Concrete Pavement," or Item 340, "Hot Mix Asphalt," to achieve required section.
- F. Finishing.** Regrade and compact disturbed topsoil. Clean roadway surface after repair operations.

351.5. Measurement. This Item will be measured by the square yard. In areas where material is excavated, as directed, to depths greater than those specified on the plans, measurement will be made by dividing the actual depth of such area by the plan depth and then multiplying this figure by the area in square yards of work performed. Calculations for each repaired area will be rounded up to the nearest 1/10 sq. yd. At each repair location, the minimum area for payment purposes will be 1 sq. yd.

For Contracts with callout work, the minimum quantity per callout is 5 sq. yd., unless otherwise shown on the plans.

351.6. Payment. The work performed and materials furnished in accordance with this Item and measured as provided under "Measurement" will be paid for at the unit price bid for "Flexible Pavement Structure Repair" of the specified depth. This price is full compensation for scarifying, removing, hauling, spreading, disposing of, and stockpiling existing pavement structure; removing objectionable or unstable material; furnishing and placing materials; maintaining completed section before surfacing; applying tack or prime coat; hauling, sprinkling, spreading, and compacting; and equipment, labor, tools, and incidentals.

354.1 to 354.3

ITEM 354

PLANING AND TEXTURING PAVEMENT

354.1. Description. Plane, or plane and texture, existing asphalt concrete pavement, asphalt-stabilized base, or concrete pavement. Texture bridge deck surfaces.

354.2. Equipment. The Engineer may require demonstration of the equipment's capabilities.

- A. Planing Machine.** Use planing machines that:
- have a minimum 6-ft. cutting width except for work areas less than 6 ft. wide;
 - are self-propelled with sufficient power, traction, and stability to maintain an accurate depth of cut and slope;
 - can cut in 1 continuous operation: 4 in. of asphalt concrete pavement, 1 in. of concrete pavement, or a combination of 2 in. of asphalt concrete pavement and 1/2 in. of concrete pavement;
 - use dual longitudinal controls capable of operating on both sides automatically from any longitudinal grade reference, which includes string line, ski, mobile string line, or matching shoe;
 - use transverse controls with an automatic system to control cross slope at a given rate;
 - use integral loading and reclaiming devices to allow cutting, removal, and discharge of the material into a truck in one operation; and
 - include devices to control dust created by the cutting action.
- B. Manual System.** Use a manual system that can achieve a uniform depth of cut, flush to all inlets, valve covers, manholes, and other appurtenances within the paved area. Use of a manual system is allowed for areas restricted to self-propelled access and for detail pavement removal.
- C. Sweeper.** Unless otherwise approved, use a street sweeper to remove cuttings and debris from the planed or textured pavement. Equip the sweeper with a water tank, dust control spray assembly, both a pick-up and a gutter broom, and a debris hopper.

354.3. Construction.

- A. Grade Reference.** When required, place grade reference points at maximum intervals of 50 ft. in accordance with Item 5, "Control of the Work." Use the control points to set the grade reference. Support the

grade reference so the maximum deflection does not exceed 1/16 in. between supports.

- B. Planing and Texturing.** Vary the speed of the machine to leave a grid or other pattern type with discontinuous longitudinal reach. Remove the pavement surface for the length, depth, and width shown on the typical section and to the established line and grades. Remove pavement to vertical lines adjacent to curbs, gutters, inlets, manholes, or other obstructions. Do not damage appurtenances or underlying pavement. Provide a planed surface that has a uniform textured appearance and riding surface. Surface should be free from gouges, continuous longitudinal grooves, ridges, oil film, and other imperfections of workmanship. Leave a uniform surface of concrete pavement free of asphalt materials when removing an asphalt concrete pavement overlay.

When an overlay on the planed pavement is not required, provide a minimum texture depth of not less than 0.05 in. Stop planing operations when surface texture depth is not sufficient. Do not exceed 3/16 in. into the original deck surface on bridges. Do not damage armor joints, sealed expansion joints, and other appurtenances.

Provide a pavement surface that, after planing, has a smooth riding quality and is true to the established line, grade, and cross section. Provide a pavement surface that does not vary more than 1/8 in. in 10 ft. Evaluate this criterion with a 10-ft. straightedge placed parallel to the centerline of the roadway. Deviations will be measured from the top of the texture. Correct any point in the surface not meeting this requirement.

Sweep pavement and gutter. Leave pavement and curb clean.

- C. Edge Treatments.** At the end of the day and for areas under traffic, slope vertical or near vertical longitudinal faces in the pavement surface in accordance with the requirements in the plans. Taper transverse faces to provide an acceptable ride.
- D. Salvaged Materials.** The Department will retain ownership of planed materials unless otherwise shown on the plans. Stockpile salvaged materials at locations shown on the plans. Prepare the stockpile site by removing vegetation and trash and by providing proper drainage. Keep salvaged paving material free from contamination during its removal, transportation, and storage. Place different types or quality of salvaged asphalt paving material into separate stockpiles. Dispose of unsalvageable material in accordance with applicable federal, state, and local regulations.

354.4 to 356.2

354.4. Measurement. This Item will be measured by the square yard of surface area for each pavement type including asphalt concrete pavement, concrete pavement, and bridge decks. Measurement will be based on the depth shown for each bid item, within the limits shown on the plans, regardless of the number of passes required. Only 1 bid item for each pavement type will apply to any 1 location.

354.5. Payment. The work performed and materials furnished in accordance with this Item and measured as provided under “Measurement” will be paid for at the unit price bid for “Planing and Texturing Asphalt Concrete Pavement,” “Planing and Texturing Concrete Pavement,” “Planing Asphalt Concrete Pavement,” or “Planing Concrete Pavement” of the depths specified, and for “Texturing Bridge Decks.”

The planing of concrete pavement to remove all asphalt concrete pavement as required under Article 354.3, “Construction,” is subsidiary to the planing of asphalt concrete pavement of the depth shown on the plans.

This price is full compensation for removing all material to the depth shown; texturing the pavement surface when texturing is shown in the bid item description; loading, hauling, and unloading; stockpiling or disposing of material; sweeping; tapering or sloping longitudinal or transverse joints as described under Section 354.3.C, “Edge Treatments”; and equipment, labor, tools, and incidentals. Demonstration work to receive approval for use of equipment will not be paid for unless work is performed in accordance with the Contract and is accepted.

ITEM 356

FABRIC UNDERSEAL

356.1. Description. Furnish and place fabric underseal in a longitudinal, full-road-width application or over pavement joints.

356.2. Materials.

A. Longitudinal, Full-Width Underseal.

- 1. Fabric.** Provide fabric meeting DMS-6220, “Fabric for Underseals.” Use roll widths shown on the plans or as approved.
- 2. Asphalt.** Provide the grade of asphalt shown on the plans and in accordance with Item 300, “Asphalts, Oils, and Emulsions.”
- 3. Blotter.** Provide screenings, natural sand, or other materials as approved.

B. Pavement Joint Underseal. Provide material in accordance with DMS-6260, “Reinforced Fabric Joint Underseal.” Use roll widths as shown on the plans or as approved.

356.3. Equipment. For longitudinal, full-width underseal, provide applicable equipment in accordance with Item 316, “Surface Treatments.”

356.4. Construction. Apply fabric underseal when the air temperature is 60°F and above, or above 50°F and rising. In all cases, do not apply when surface temperature is below 50°F. Do not apply when, according to the Engineer, weather conditions are not suitable. Measure air temperature in the shade and away from artificial heat.

A. Longitudinal, Full-Width Underseal.

- 1. Surface Preparation.** Prepare the surface by cleaning off dirt, dust, or other debris. Set string lines for alignment if required. Remove existing raised pavement markers in accordance with the plans. When shown on the plans, remove vegetation and blade pavement edges.
- 2. Asphalt Binder Application.** Apply asphalt binder:
 - with an asphalt distributor unless otherwise approved,
 - at the rate shown on the plans or as directed,
 - within 15°F of the temperature selected by the Engineer,
 - approximately 6 in. outside the fabric width, and
 - with paper or other approved material at the beginning and end of each shot to construct a straight transverse joint and to prevent overlapping of the asphalt.

Unless otherwise approved, match longitudinal joints with the lane lines. The Engineer may require a string line if necessary to keep joints straight with no overlapping. Do not contaminate asphalt binder.

- 3. Fabric Placement.** Immediately after asphalt binder application, align the fabric and broom or roll it in place. If skewed alignment occurs, cut the fabric, overlap the cut fabric to create a transverse joint, and begin application again. Roll or broom fabric onto the asphalt binder in a manner that prevents air bubbles from forming under the fabric. If wind prevents proper adherence of the fabric to the asphalt binder, especially at the edges, provide an alternate means of securing the edges to the pavement. Cease underseal application if the Engineer determines that wind conditions prevent proper placement.

356.5 to 356.5

- a. Transverse Joints.** Overlap transverse joints by a minimum of 6 in. If traffic is allowed directly on the underseal, make all transverse joints with the top layer in the direction of traffic. At transverse joints, secure ends of overlapping fabric layer by nailing or other approved means.
 - b. Longitudinal Joints.** Overlap longitudinal joints by a minimum of 4 in. Apply additional asphalt binder to secure longitudinal fabric joints.
- 4. Blotter.** Apply blotter as directed to the top of the underseal to absorb excess asphalt binder. Remove any excess blotter as directed.

B. Pavement Joint Underseal.

- 1. Surface Preparation.** Remove dirt, dust, or other debris from all joints and from the area on both sides of the joint that will be in contact with the installed underseal. Other preparation for proper adherence may be required as shown on the plans.
- 2. Fabric Placement.** For transverse pavement joints, do not allow joints or laps in the underseal material. Minimize underseal material joints in longitudinal pavement joints, and do not allow overlap. Remove any protective coatings from the self-adhering layer of the fabric underseal. Center the fabric width over the joint. Apply fabric to the joint with a minimum of 5 in. on each side or as specified on the plans. Roll fabric in place to ensure adherence of the self-adhering binder. Do not allow air bubbles under the fabric.

356.5. Measurement.

A. Longitudinal, Full-Width Underseal.

- 1. Asphalt Binder.** Asphalt binder will be measured as follows.
 - a. Volume.** Volume measurements will be made at the point of application on the road as gallons used at the application temperature, as directed, in the accepted fabric underseal.
 - b. Weight.** Weight measurements will be by the ton in accordance with Item 520, "Weighing and Measuring Equipment." At the end of the project, deduct any remaining material from quantities delivered to determine pay quantities.
- 2. Fabric.** Fabric will be measured by the square yard based on the widths shown on the plans and the lengths measured at placement

with no allowance for overlapping at transverse and longitudinal joints.

- B. Pavement Joint Underseal.** Pavement joint underseal will be measured by the foot.

356.6. Payment. The work performed and materials furnished in accordance with this Item and measured as provided under “Measurement” are paid for at the unit prices bid for “Asphalt Binder” of the type and grade specified and for “Fabric” for full-width underseals and “Pavement Joint Underseal” of the product width specified for pavement joint underseals. These prices are full compensation for cleaning and preparing the existing pavement, including removal of raised pavement markers; furnishing, preparing, hauling, and placing materials, including blotter; manipulation, including rolling and brooming; and equipment, labor, tools, and incidentals.

ITEM 358

ASPHALT CONCRETE SURFACE REHABILITATION

358.1. Description. Heat; scarify; if required, add asphalt, recycling agent, and fresh hot mix asphalt; mix; place; level; and compact recycled asphalt concrete.

358.2. Materials.

- A. Hot-Mix Asphalt.** If required, furnish fresh hot-mix asphalt of the gradation determined in Section 358.4.A, “Mixture Design.” Use materials meeting the requirements of Article 340.2, “Materials,” to produce the fresh hot-mix asphalt.
- B. Asphalt and Recycling Agent.** If required, furnish asphalt, recycling agent, or both according to the requirements of Section 358.4.A, “Mixture Design,” and meeting requirements of Item 300, “Asphalt, Oils, and Emulsions.”

358.3. Equipment.

- A. Processing Equipment.** Provide equipment for heating, scarifying, mixing, placing, and finishing that meets the following requirements.
- 1. Heating Mechanism.** Supply a heating mechanism, under a closed or shielded hood, capable of heating asphalt concrete pavement to a temperature that allows scarification to the desired depth without producing undesirable pollutants.

358.4 to 358.4

2. **Scarifier.** Provide scarifier sections capable of uniformly loosening the asphalt concrete pavement. When shown on the plans, furnish a scarifier with height adjustments to clear manholes or other obstructions.
 3. **Gathering, Adding Materials, Mixing, Distributing, Spreading, and Finishing.** Provide equipment capable of:
 - gathering heated, scarified hot-mix asphalt concrete;
 - adding asphalt or recycling agent at the required rate;
 - adding fresh hot-mix asphalt at the required rate;
 - uniformly mixing all ingredients;
 - distributing the blended mixture over the width being processed; and
 - spreading and finishing to produce a smooth surface meeting the requirements of the typical cross section.
 4. **Onboard Pug Mill.** If required on the plans, provide an onboard pug mill.
- B. Rollers.** Provide rollers meeting requirements of Article 210.2, “Equipment.”
- C. Mobile Testing Laboratory.** If shown on the plans, furnish a mobile testing laboratory meeting the requirements of Tex-237-F and a Level 1A certified laboratory technician who is qualified under the Department’s approved program. Perform tests necessary to control plant production. The Department will perform all acceptance testing.

358.4. Construction. Rehabilitate existing asphalt concrete pavement to meet the typical sections shown on the plans and the lines and grades established by the Engineer.

- A. Mixture Design.** Obtain a representative sample, to the depth specified, of the in-place asphalt concrete for rehabilitation. Using materials described in Article 358.2, “Materials,” provide a mixture design by weight in accordance with Tex-204-F, Part I, to restore the in-place asphalt concrete pavement to the mixture type and binder properties shown on the plans or as approved.
- B. Heating, Scarifying, and Placement.** Protect from heat damage all trees, shrubs, and other landscaping that is adjacent to the pavement. Before beginning heating and scarifying, remove all dirt and other debris from the pavement surface by blading, brooming, or other approved methods.

Heat, scarify, and rework pavement surface to the widths and depths shown on the plans. Control heating to ensure uniform heat penetration and to prevent differential softening of the pavement. Do not char the asphalt or break aggregate particles. Keep the temperature of material immediately behind the scarifier between 225°F and 325°F. Gather the scarified material and uniformly add asphalt, recycling agent, and fresh hot-mix asphalt to the scarified material in accordance with the mixture design developed in Section 358.4.A, "Mixture Design." Mix all ingredients uniformly. Distribute the homogenous mixture over the width being processed. Spread and finish to produce a smooth surface according to the typical cross section.

When making a pass adjacent to a previously placed mat, locate the longitudinal joint at least 2 in. horizontally into the previously placed mat.

- C. Compaction.** Begin compaction before material temperature falls below 190°F, and complete all rolling before material temperature drops below 175°F. The Engineer may modify the temperature requirements if necessary for proper compaction.

Use at least 1 tandem roller, 1 pneumatic-tire roller, and 1 finish roller. Use other compaction equipment producing equivalent compaction as approved. Continue rolling until no further compaction can be obtained and all roller marks are eliminated. Use tamps to compact areas not accessible to rollers or in areas where rollers will not provide thorough compaction.

- D. Ride Quality.** Use Surface Test Type A to evaluate ride quality in accordance with Item 585, "Ride Quality for Pavement Surfaces," unless otherwise shown on the plans.

358.5. Measurement. Asphalt concrete surface rehabilitation will be measured by the square yard.

358.6. Payment. Asphalt concrete surface rehabilitation will be paid for at the unit price bid for "Asphalt Concrete Surface Rehabilitation" of the depth specified. This price is full compensation for cleaning existing pavement; materials (including additional aggregate, new hot-mix asphalt, asphalt, and rejuvenating agent); heating, scarifying, mixing, relaying, rolling, and finishing; and equipment, labor, tools, and incidentals.

Pay adjustment for ride quality, when required, will be determined in accordance with Item 585, "Ride Quality for Pavement Surfaces."

360.1 to 360.2

ITEM 360 CONCRETE PAVEMENT

360.1. Description. Construct hydraulic cement concrete pavement with or without curbs on the concrete pavement.

360.2. Materials.

A. Hydraulic Cement Concrete. Provide hydraulic cement concrete in accordance with Item 421, "Hydraulic Cement Concrete," except that strength over-design is not required. Provide Class P concrete designed to meet a minimum average flexural strength of 570 psi or a minimum average compressive strength of 3,500 psi at 7 days or a minimum average flexural strength of 680 psi or a minimum average compressive strength of 4,400 psi at 28 days. Test in accordance with Tex-448-A or Tex-418-A.

When shown on the plans or allowed, provide Class HES concrete for very early opening of small pavement areas or leave-outs to traffic. Design Class HES to meet the requirements of Class P and a minimum average flexural strength of 400 psi or a minimum average compressive strength of 2,600 psi in 24 hr., unless other early strength and time requirements are shown on the plans or allowed. No strength over-design is required. Type III cement is allowed for Class HES concrete.

Use Class A or P concrete for curbs that are placed separately from the pavement. Provide concrete that is workable and cohesive, possesses satisfactory finishing qualities, and conforms to the mix design and mix design slump.

B. Reinforcing Steel. Provide Grade 60 deformed steel for bar reinforcement in accordance with Item 440, "Reinforcing Steel." Provide approved positioning and supporting devices (baskets and chairs) capable of securing and holding the reinforcing steel in proper position before and during paving. Provide corrosion protection when shown on the plans.

1. Dowels. Provide smooth, straight dowels of the size shown on the plans, free of burrs, and conforming to the requirements of Item 440, "Reinforcing Steel." Coat dowels with a thin film of grease or other approved de-bonding material. Provide dowel caps on the lubricated end of each dowel bar used in an expansion joint. Provide dowel caps filled with a soft compressible material with enough range of movement to allow complete closure of the expansion joint.

2. **Tie Bars.** Provide straight deformed steel tie bars. Provide either multiple-piece tie bars or single-piece tie bars as shown on the plans. Provide multiple-piece tie bars composed of 2 pieces of deformed reinforcing steel with a coupling capable of developing a minimum tensile strength of 125% of the design yield strength of the deformed steel when tensile-tested in the assembled configuration. Provide a minimum length of 33 diameters of the deformed steel in each piece. Use multiple-piece tie bars from the list of “Prequalified Multiple Piece Tie Bar Producers” maintained by the Construction Division, or submit samples for testing in accordance with Tex-711-I.
- C. **Curing Materials.** Provide Type 2 membrane curing compound conforming to DMS-4650, “Hydraulic Cement Concrete Curing Materials and Evaporation Retardants.” Provide SS-1 emulsified asphalt conforming to Item 300, “Asphalts, Oils, and Emulsions,” for concrete pavement to be overlaid with asphalt concrete under this Contract unless otherwise shown on the plans or approved. Provide materials for other methods of curing conforming to the requirements of Item 420, “Concrete Structures.”
- D. **Epoxy.** Provide Type III epoxy in accordance with DMS-6100, “Epoxies and Adhesives,” for installing all drilled-in reinforcing steel.
- E. **Evaporation Retardant.** Provide evaporation retardant conforming to DMS-4650, “Hydraulic Cement Concrete Curing Materials and Evaporation Retardants.”
- F. **Joint Sealants and Fillers.** Provide Class 5 or Class 8 joint-sealant materials and fillers unless otherwise shown on the plans or approved and other sealant materials of the size, shape, and type shown on the plans in accordance with DMS-6310, “Joint Sealants and Fillers.”

360.3. Equipment. Furnish and maintain all equipment in good working condition. Use measuring, mixing, and delivery equipment conforming to the requirements of Item 421, “Hydraulic Cement Concrete.” Obtain approval for other equipment used.

- A. **Placing, Consolidating, and Finishing Equipment.** Provide approved self-propelled paving equipment that uniformly distributes the concrete with minimal segregation and provides a smooth machine-finished consolidated concrete pavement conforming to plan line and grade. Provide an approved automatic grade control system on slip-forming equipment. Provide approved mechanically operated finishing floats

360.3 to 360.3

capable of producing a uniformly smooth pavement surface. Provide equipment capable of providing a fine, light water fog mist.

Provide mechanically operated vibratory equipment capable of adequately consolidating the concrete. Provide immersion vibrators on the paving equipment at sufficiently close intervals to provide uniform vibration and consolidation of the concrete over the entire width and depth of the pavement and in accordance with the manufacturer's recommendations. Provide immersion vibrator units that operate at a frequency in air of at least 8,000 cycles per minute. Provide enough hand-operated immersion vibrators for timely and proper consolidation of the concrete along forms, at joints and in areas not covered by other vibratory equipment. Surface vibrators may be used to supplement equipment-mounted immersion vibrators. Provide tachometers to verify the proper operation of all vibrators.

For small or irregular areas or when approved, the paving equipment described in this Section is not required.

B. Forming Equipment.

1. Pavement Forms. Provide metal side forms of sufficient cross-section, strength, and rigidity to support the paving equipment and resist the impact and vibration of the operation without visible springing or settlement. Use forms that are free from detrimental kinks, bends, or warps that could affect ride quality or alignment. Provide flexible or curved metal or wood forms for curves of 100-ft. radius or less.

2. Curb Forms. Provide curb forms for separately placed curbs that are not slipformed that conform to the requirements of Item 529, "Concrete Curb, Gutter, and Combined Curb and Gutter."

C. Reinforcing Steel Inserting Equipment. Provide inserting equipment that accurately inserts and positions reinforcing steel in the plastic concrete parallel to the profile grade and horizontal alignment in accordance to plan details.

D. Texturing Equipment.

1. Carpet Drag. Provide a carpet drag mounted on a work bridge or a moveable support system. Provide a single piece of carpet of sufficient transverse length to span the full width of the pavement being placed and adjustable so that a sufficient longitudinal length of carpet is in contact with the concrete being placed to produce the desired texture. Obtain approval to vary the length and width of the carpet to accommodate specific applications. Use an artificial

grass-type carpet having a molded polyethylene pile face with a blade length of 5/8 in. to 1 in., a minimum weight of 70 oz. per square yard, and a strong, durable, rot-resistant backing material bonded to the facing.

2. **Tining Equipment.** Provide a self-propelled transverse metal tine device equipped with 4-in. to 6-in. steel tines and with cross-section approximately 1/32 in. thick by 1/12 in. wide, spaced at 1 in., center-to-center. Hand-operated tining equipment that produces an equivalent texture may be used only on small or irregularly shaped areas or, when permitted, in emergencies due to equipment breakdown.
- E. **Curing Equipment.** Provide a self-propelled machine for applying membrane curing compound using mechanically pressurized spraying equipment with atomizing nozzles. Provide equipment and controls that maintain the required uniform rate of application over the entire paving area. Provide curing equipment that is independent of all other equipment when production rates are such that the first application of membrane curing compound cannot be accomplished immediately after texturing and after free moisture has disappeared. Hand-operated pressurized spraying equipment with atomizing nozzles may only be used on small or irregular areas or, when permitted, in emergencies due to equipment breakdown.
 - F. **Sawing Equipment.** Provide power-driven concrete saws to saw the joints shown on the plans. Provide standby power-driven concrete saws during concrete sawing operations. Provide adequate illumination for nighttime sawing.
 - G. **Grinding Equipment.** When required, provide self-propelled powered grinding equipment that is specifically designed to smooth and texture concrete pavement using circular diamond blades. Provide equipment with automatic grade control capable of grinding at least a 3-ft. width longitudinally in each pass without damaging the concrete.
 - H. **Testing Equipment.** Provide testing equipment regardless of job-control testing responsibilities in accordance with Item 421, "Hydraulic Cement Concrete," unless otherwise shown in the plans or specified.
 - I. **Coring Equipment.** When required, provide coring equipment capable of extracting cores in accordance with the requirements of Tex-424-A.
 - J. **Miscellaneous Equipment.** Furnish both 10-ft. and 15-ft. steel or magnesium long-handled standard straightedges. Furnish enough work bridges, long enough to span the pavement, for finishing and inspection

360.4 to 360.4

operations. Furnish date stencils to impress pavement placement dates into the fresh concrete, with numerals approximately 2 in. high by 1 in. wide by 1/4 in. deep.

360.4. Construction. Obtain approval for adjustments to plan grade-line to maintain thickness over minor subgrade or base high spots while maintaining clearances and drainage. Maintain subgrade or base in a smooth, clean, compacted condition in conformity with the required section and established grade until the pavement concrete is placed. Keep subgrade or base damp with water sufficiently in advance of placing pavement concrete. Adequately light the active work areas for all nighttime operations. Provide and maintain tools and materials to perform testing.

- A. Paving and Quality Control Plan.** Submit a paving and quality control plan for approval before beginning pavement construction operations. Include details of all operations in the concrete paving process, including longitudinal construction joint layout, sequencing, curing, lighting, early opening, leave-outs, sawing, inspection, testing, construction methods, other details and description of all equipment. List certified personnel performing the testing. Submit revisions to the paving and quality control plan for approval.
- B. Job-Control Testing.** Unless otherwise shown on the plans, perform all fresh and hardened concrete job-control testing at the specified frequency. Provide job-control testing personnel meeting the requirements of Item 421, "Hydraulic Cement Concrete." Provide and maintain testing equipment, including strength testing equipment at a location acceptable to the Engineer. Use of a commercial laboratory is acceptable. Maintain all testing equipment calibrated in accordance with pertinent test methods. Make strength-testing equipment available to the Engineer for verification testing.

Provide the Engineer the opportunity to witness all tests. The Engineer may require a retest if not given the opportunity to witness. Furnish a copy of all test results to the Engineer daily. Check the first few concrete loads for slump, air, and temperature on start-up production days to check for concrete conformance and consistency. Sample and prepare strength test specimens (2 specimens per test) on the first day of production and for each 3,000 sq. yd. or fraction thereof of concrete pavement thereafter. Prepare at least 1 set of strength-test specimens for each production day. Perform slump, air, and temperature tests each time strength specimens are made. Monitor concrete temperature to ensure that concrete is consistently within the temperature requirements. The Engineer will direct random job-control sampling

and testing. Immediately investigate and take corrective action as approved if any Contractor test result, including tests performed for verification purposes, does not meet specification requirements.

When job-control testing by the Contractor is waived by the plans, the Engineer will perform the testing; however, this does not waive the Contractor's responsibility for providing materials and work in accordance with this Item.

1. **Job-Control Strength.** Unless otherwise shown on the plans or permitted by the Engineer, use 7-day job-control concrete strength testing in accordance with Tex-448-A or Tex-418-A.

For 7-day job-control by flexural strength, use a flexural strength of 520 psi or a lower job-control strength value proven to meet a 28-day flexural strength of 680 psi as correlated in accordance with Tex-427-A. For 7-day job-control by compressive strength, use a compressive strength of 3,200 psi or a lower job-control strength value proven to meet a 28-day compressive strength of 4,400 psi as correlated in accordance with Tex-427-A.

Job control of concrete strength may be correlated to an age other than 7 days in accordance with Tex-427-A when approved. Job-control strength of Class HES concrete is based on the required strength and time.

When a job-control concrete strength test value is more than 10% below the required job-control strength or when 3 consecutive job-control strength values fall below the required job-control strength, investigate the strength test procedures, the quality of materials, the concrete production operations, and other possible problem areas to determine the cause. Take necessary action to correct the problem, including redesign of the concrete mix if needed. The Engineer may suspend concrete paving if the Contractor is unable to identify, document, and correct the cause of low strength test values in a timely manner. If any job-control strength is more than 15% below the required job-control strength, the Engineer will evaluate the structural adequacy of the pavements. When directed, remove and replace pavements found to be structurally inadequate at no additional cost.

2. **Split-Sample Verification Testing.** Perform split-sample verification testing with the Engineer on random samples taken and split by the Engineer at a rate of at least 1 for every 10 job-control samples. The Engineer will evaluate the results of split-sample verification testing. Immediately investigate and take

360.4 to 360.4

corrective action as approved when results of split-sample verification testing differ more than the allowable differences shown in Table 1, or when the average of 10 job-control strength results and the Engineer's split-sample strength result differ by more than 10%.

Table 1
Verification Testing Limits

Test Method	Allowable Differences
Temperature, Tex-422-A	2°F
Slump, Tex-415-A	1 in.
Air content, Tex-414-A or Tex-416-A	1%
Flexural strength, Tex-448-A	19%
Compressive strength, Tex-418-A	10%

- C. Reinforcing Steel and Joint Assemblies.** Accurately place and secure in position all reinforcing steel as shown on the plans. Place dowels at mid-depth of the pavement slab, parallel to the surface. Place dowels for transverse contraction joints parallel to the pavement edge. Tolerances for location and alignment of dowels will be shown on the plans. Stagger the longitudinal reinforcement splices to avoid having more than 1/3 of the splices within a 2-ft. longitudinal length of each lane of the pavement. Use multiple-piece tie bars or drill and epoxy grout tie bars at longitudinal construction joints. Verify that tie bars that are drilled and epoxied into concrete at longitudinal construction joints develop a pullout resistance equal to a minimum of 3/4 of the yield strength of the steel after 7 days. Test 15 bars using ASTM E 488, except that alternate approved equipment may be used. All 15 tested bars must meet the required pullout strength. If any of the test results do not meet the required minimum pullout strength, perform corrective measures to provide equivalent pullout resistance. Repair damage from testing. Acceptable corrective measures include but are not limited to installation of additional or longer tie bars.
- 1. Manual Placement.** Secure reinforcing bars at alternate intersections with wire ties or locking support chairs. Tie all splices with wire.
 - 2. Mechanical Placement.** If mechanical placement of reinforcement results in steel misalignment or improper location, poor concrete consolidation, or other inadequacies, complete the work using manual methods.
- D. Joints.** Install joints as shown on the plans. Joint sealants are not required on concrete pavement that is to be overlaid with asphaltic

materials. Clean and seal joints in accordance with Item 438, “Cleaning and Sealing Joints and Cracks (Rigid Pavement and Bridge Decks).” Repair excessive spalling of the joint saw groove using an approved method before installing the sealant. Seal all joints before opening the pavement to all traffic. When placing of concrete is stopped, install a rigid transverse bulkhead, accurately notched for the reinforcing steel and shaped accurately to the cross-section of the pavement.

1. **Placing Reinforcement at Joints.** Where the plans require an assembly of parts at pavement joints, complete and place the assembly at the required location and elevation with all parts rigidly secured in the required position. Accurately notch joint materials for the reinforcing steel.
2. **Transverse Construction Joints.**
 - a. **Continuously Reinforced Concrete Pavement (CRCP).** Install additional longitudinal reinforcement through the bulkhead when shown on the plans. Protect the reinforcing steel immediately beyond the construction joint from damage, vibration, and impact.
 - b. **Concrete Pavement Contraction Design (CPCD).** When the placing of concrete is intentionally stopped, install and rigidly secure a complete joint assembly and bulkhead in the planned transverse contraction joint location. When the placing of concrete is unintentionally stopped, install a transverse construction joint either at a planned transverse contraction joint location or mid-slab between planned transverse contraction joints. For mid-slab construction joints, install tie bars of the size and spacing used in the longitudinal joints.
 - c. **Curb Joints.** Provide joints in the curb of the same type and location as the adjacent pavement. Use expansion joint material of the same thickness, type, and quality required for the pavement and of the section shown for the curb. Extend expansion joints through the curb. Construct curb joints at all transverse pavement joints. For non-monolithic curbs, place reinforcing steel into the plastic concrete pavement as shown on the plans unless otherwise approved. Form or saw the weakened plane joint across the full width of concrete pavement and through the monolithic curbs. Construct curb joints in accordance with Item 529, “Concrete Curb, Gutter, and Combined Curb and Gutter.”

360.4 to 360.4

- E. Placing and Removing Forms.** Use clean and oiled forms. Secure forms on a base or firm subgrade that is accurately graded and that provides stable support without deflection and movement by form riding equipment. Pin every form at least at the middle and near each end. Tightly join and key form sections together to prevent relative displacement.

Set side forms far enough in advance of concrete placement to permit inspection. Check conformity of the grade, alignment, and stability of forms immediately before placing concrete, and make all necessary corrections. Use a straightedge or other approved method to test the top of forms to ensure that the ride quality requirements for the completed pavement will be met. Stop paving operations if forms settle or deflect more than 1/8 in. under finishing operations. Reset forms to line and grade, and refinish the concrete surface to correct grade.

Avoid damage to the edge of the pavement when removing forms. Repair damage resulting from form removal and honeycombed areas with a mortar mix within 24 hr. after form removal unless otherwise approved. Clean joint face and repair honeycombed or damaged areas within 24 hr. after a bulkhead for a transverse construction joint has been removed unless otherwise approved. When forms are removed before 72 hr. after concrete placement, promptly apply membrane curing compound to the edge of the concrete pavement.

Forms that are not the same depth as the pavement but are within 2 in. of that depth are permitted if the subbase is trenched or the full width and length of the form base is supported with a firm material to produce the required pavement thickness. Promptly repair the form trench after use. Use flexible or curved wood or metal forms for curves of 100-ft. radius or less.

- F. Concrete Delivery.** Clean delivery equipment as necessary to prevent accumulation of old concrete before loading fresh concrete. Use agitated delivery equipment for concrete designed to have a slump of more than 5 in. Segregated concrete is subject to rejection. Place agitated concrete within 60 min. after batching. Place non-agitated concrete within 45 min. after batching. In hot weather or under conditions causing quick setting of the concrete, times may be reduced by the Engineer. Time limitations may be extended if the Contractor can demonstrate that the concrete can be properly placed, consolidated, and finished without the use of additional water.
- G. Concrete Placement.** Do not allow the pavement edge to deviate from the established paving line by more than 1/2 in. at any point. Place the

concrete as near as possible to its final location, and minimize segregation and rehandling. Where hand spreading is necessary, distribute concrete using shovels. Do not use rakes or vibrators to distribute concrete.

1. **Pavement.** Consolidate all concrete by approved mechanical vibrators operated on the front of the paving equipment. Use immersion-type vibrators that simultaneously consolidate the full width of the placement when machine finishing. Keep vibrators from dislodging reinforcement. Use hand-operated vibrators to consolidate concrete in areas not accessible to the machine-mounted vibrators. Do not operate machine-mounted vibrators while the paving equipment is stationary. Vibrator operations are subject to review.
2. **Date Imprinting.** Imprint dates in the fresh concrete indicating the date of the concrete placement. Make impressions approximately 1 ft. from the outside longitudinal construction joint or edge of pavement and approximately 1 ft. from the transverse construction joint at the beginning of the placement day. Orient the impressions to be read from the outside shoulder in the direction of final traffic. Impress date in DD-MM-YY format. Imprinting of the Contractor name or logo in similar size characters to the date is allowed.
3. **Curbs.** Where curbs are placed separately, conform to the requirements of Item 529, "Concrete Curb, Gutter, and Combined Curb and Gutter."
4. **Temperature Restrictions.** Place concrete that is between 40°F and 95°F when measured in accordance with Tex-422-A at the time of discharge, except that concrete may be used if it was already in transit when the temperature was found to exceed the allowable maximum. Take immediate corrective action or cease concrete production when the concrete temperature exceeds 95°F.

Do not place concrete when the ambient temperature in the shade is below 40°F and falling unless approved. Concrete may be placed when the ambient temperature in the shade is above 35°F and rising or above 40°F. When temperatures warrant protection against freezing, protect the pavement with an approved insulating material capable of protecting the concrete for the specified curing period. Submit for approval proposed measures to protect the concrete from anticipated freezing weather for the first 72 hr. after placement. Repair or replace all concrete damaged by freezing.

H. Spreading and Finishing. Finish all concrete pavement with approved self-propelled equipment. Use power-driven spreaders, power-driven vibrators, power-driven strike-off, and screed, or approved alternate equipment. Use the transverse finishing equipment to compact and strike off the concrete to the required section and grade without surface voids. Use float equipment for final finishing. Use concrete with a consistency that allows completion of all finishing operations without addition of water to the surface. Use the minimal amount of water fog mist necessary to maintain a moist surface. Reduce fogging if float or straightedge operations result in excess slurry.

1. **Finished Surface.** Perform sufficient checks with long-handled 10-ft. and 15-ft. straightedges on the plastic concrete to ensure that the final surface is within the tolerances specified in Surface Test A in Item 585, "Ride Quality for Pavement Surfaces." Check with the straightedge parallel to the centerline.
2. **Maintenance of Surface Moisture.** Prevent surface drying of the pavement before application of the curing system. Accomplish this by fog applications of evaporation retardant on the pavement surface. Apply evaporation retardant at the rate recommended by the manufacturer. Reapply the evaporation retardant as needed to maintain the concrete surface in a moist condition until curing system is applied. Do not use evaporation retardant as a finishing aid. Failure to take acceptable precautions to prevent surface drying of the pavement will be cause for shut down of pavement operations.
3. **Surface Texturing.** Perform surface texturing using a combination of a carpet drag and metal tining. Complete final texturing before the concrete has attained its initial set. Draw the carpet drag longitudinally along the pavement surface with the carpet contact surface area adjusted to provide a satisfactory coarsely textured surface.

A metal-tine texture finish is required unless otherwise shown on the plans. Provide the metal-tine finish immediately after the concrete surface has set enough for consistent tining. Operate the metal-tine device to obtain grooves spaced at 1 in., approximately 3/16 in. deep, with a minimum depth of 1/8 in., and approximately 1/12 in. wide. Do not overlap a previously tined area. Use manual methods for achieving similar results on ramps and other irregular sections of pavements. Repair damage to the edge of the slab and

joints immediately after texturing. Do not tine pavement that will be overlaid.

4. **Small or Irregular Placements.** Where machine placements and finishing of concrete pavement are not practical, use hand equipment and procedures that produce a consolidated and finished pavement section to the line and grade.
 5. **Emergency Procedures.** Use hand-operated equipment for applying texture, evaporation retardant, and cure in the event of equipment breakdown.
- I. **Curing.** Keep the concrete pavement surface from drying by water fogging until the curing material has been applied. Maintain and promptly repair damage to curing materials on exposed surfaces of concrete pavement continuously for at least 3 curing days. A curing day is defined as a 24-hr. period when either the temperature taken in the shade away from artificial heat is above 50°F for at least 19 hr. or when the surface temperature of the concrete is maintained above 40°F for 24 hr. Curing begins when the concrete curing system has been applied. Stop concrete paving if curing compound is not being applied promptly and maintained adequately. Other methods of curing in accordance with Item 420, “Concrete Structures,” may be used when specified or approved.
1. **Membrane Curing.** After texturing and immediately after the free surface moisture has disappeared, spray the concrete surface uniformly with 2 coats of membrane curing compound at an individual application rate of not more than 180 sq. ft. per gallon. Apply the first coat within 10 min. after completing texturing operations. Apply the second coat within 30 min. after completing texturing operations.

Before and during application, maintain curing compounds in a uniformly agitated condition, free of settlement. Do not thin or dilute the curing compound.

Where the coating shows discontinuities or other defects or if rain falls on the newly coated surface before the film has dried enough to resist damage, apply additional compound at the same rate of coverage to correct the damage. Ensure that the curing compound coats the sides of the tining grooves.
 2. **Asphalt Curing.** When an asphaltic concrete overlay is required, apply a uniform coating of asphalt curing at a rate of 90 to 180 sq. ft. per gallon as required. Apply curing immediately after texturing

360.4 to 360.4

and just after the free moisture (sheen) has disappeared. Obtain approval to add water to the emulsion to improve spray distribution. Maintain the asphalt application rate when using diluted emulsions. Maintain the emulsion in a mixed condition during application.

- 3. Curing Class HES Concrete.** For all Class HES concrete pavement, provide membrane curing in accordance with Section 360.4.I.1, “Membrane Curing,” followed promptly by water curing until opening strength is achieved but not less than 24 hr.
- J. Sawing Joints.** Saw joints to the depth shown on the plans as soon as sawing can be accomplished without damage to the pavement regardless of time of day or weather conditions. Some minor raveling of the saw cut is acceptable. Use a chalk line, string line, sawing template, or other approved method to provide a true joint alignment. Provide enough saws to match the paving production rate to ensure sawing completion at the earliest possible time to avoid uncontrolled cracking. Reduce paving production if necessary to ensure timely sawing of joints. Promptly restore membrane cure damaged within the first 72 hr. of curing.
- K. Protection of Pavement and Opening to Traffic.** Testing for early opening is the responsibility of the Contractor regardless of job-control testing responsibilities unless otherwise shown in the plans or directed. Testing result interpretation for opening to traffic is subject to the approval of the Engineer.
 - 1. Protection of Pavement.** Erect and maintain barricades and other standard and approved devices that will exclude all vehicles and equipment from the newly placed pavement for the periods specified. Before opening to traffic, protect the pavement from damage due to crossings using approved methods. Where a detour is not readily available or economically feasible, an occasional crossing of the roadway with overweight equipment may be permitted for relocating equipment only but not for hauling material. When an occasional crossing of overweight equipment is permitted, temporary matting or other approved methods may be required.

Maintain an adequate supply of sheeting or other material to cover and protect fresh concrete surface from weather damage. Apply as needed to protect the pavement surface from weather.

2. **Opening Pavement to All Traffic.** Pavement that is 7 days old may be opened to all traffic. Before opening to traffic, clean pavement, place stable material against the pavement edges, seal joints, and perform all other traffic safety related work.
3. **Opening Pavement to Construction Equipment.** Unless otherwise shown on the plans, concrete pavement may be opened early to concrete paving equipment and related delivery equipment after the concrete is at least 48 hr. old and opening strength has been demonstrated in accordance with Section 360.4.K.4, “Early Opening to All Traffic,” before curing is complete. Keep delivery equipment at least 2 ft. from the edge of the concrete pavement. Keep tracks of the paving equipment at least 1 ft. from the pavement edge. Protect textured surfaces from the paving equipment. Restore damaged membrane curing as soon as possible. Repair pavement damaged by paving or delivery equipment before opening to all traffic.
4. **Early Opening to All Traffic.** Concrete pavement may be opened after curing is complete and the concrete has attained a flexural strength of 450 psi or a compressive strength of 2,800 psi, except that pavement using Class HES concrete may be opened after 24 hr. if the specified strength is achieved.
 - a. **Strength Testing.** Test concrete specimens cured under the same conditions as the portion of the pavement involved.
 - b. **Maturity Method.** Unless otherwise shown on the plans, the maturity method, Tex-426-A, may be used to estimate concrete strength for early opening pavement to traffic. Install at least 2 maturity thermocouples for each day’s placement in areas where the maturity method will be used for early opening. Thermocouples, when used, will be installed near the days final placement for areas being evaluated for early opening. Use test specimens to verify the strength–maturity relationship in accordance with Tex-426-A, starting with the first day’s placement corresponding to the early opening pavement section.

After the first day, verify the strength–maturity relationship at least every 10 days of production. Establish a new strength–maturity relationship when the strength specimens deviate more than 10% from the maturity-estimated strengths. Suspend use of the maturity method for opening pavements to traffic when the strength–maturity relationship deviates by

360.4 to 360.4

more than 10% until a new strength–maturity relationship is established.

When the maturity method is used intermittently or for only specific areas, the frequency of verification will be as determined by the Engineer.

5. **Emergency Opening to Traffic.** Under emergency conditions, when the pavement is at least 72 hr. old, open the pavement to traffic when directed in writing. Remove all obstructing materials, place stable material against the pavement edges, and perform other work involved in providing for the safety of traffic as required for emergency opening.
- L. **Pavement Thickness.** The Engineer will check the thickness in accordance with Tex-423-A unless other methods are shown on the plans. The Engineer will perform 1 thickness test consisting of 1 reading at approximately the center of each lane every 500 ft. or fraction thereof. Core where directed in accordance with Tex-424-A to verify deficiencies of more than 0.2 in. from plan thickness and to determine the limits of deficiencies of more than 0.75 in. from plan thickness. Fill core holes using a concrete mixture and method approved by the Engineer.
 1. **Thickness Deficiencies Greater than 0.2 in.** When any depth test measured in accordance with Tex-423-A is deficient by more than 0.2 in. from the plan thickness, take one 4-in. diameter core at that location to verify the measurement.

If the core is deficient by more than 0.2 in. but not by more than 0.75 in. from the plan thickness, take 2 additional cores from the unit (as defined in Section 360.4.L.3, “Pavement Units for Payment Adjustment”) at intervals of at least 150 ft. and at locations selected by the Engineer, and determine the thickness of the unit for payment purposes by averaging the length of the 3 cores. In calculations of the average thickness of this unit of pavement, measurements in excess of the specified thickness by more than 0.2 in. will be considered as the specified thickness plus 0.2 in.
 2. **Thickness Deficiencies Greater than 0.75 in.** If a core is deficient by more than 0.75 in., take additional cores at 10 ft. intervals in each direction parallel to the centerline to determine the boundary of the deficient area. The Engineer will evaluate any area of pavement found deficient in thickness by more than 0.75 in. but not more than 1 in. As directed, remove and replace the deficient

areas without additional compensation or retain deficient areas without compensation. Remove and replace any area of pavement found deficient in thickness by more than 1 in. without additional compensation.

- 3. Pavement Units for Payment Adjustment.** Limits for applying a payment adjustment for deficient pavement thickness from 0.20 in. to not more than 0.75 in. are 500 ft. of pavement in each lane. Lane width will be as shown on typical sections and pavement design standards.

For greater than 0.75 in. deficient thickness, the limits for applying zero payment or requiring removal will be defined by coring or equivalent nondestructive means as determined by the Engineer. The remaining portion of the unit determined to be less than 0.75 in. deficient will be subject to the payment adjustment based on the average core thickness at each end of the 10 ft. interval investigation as determined by the Engineer.

Shoulders will be measured for thickness unless otherwise shown on the plans. Shoulders 6 ft. wide or wider will be considered as lanes. Shoulders less than 6 ft. wide will be considered part of the adjacent lane.

Limits for applying payment adjustment for deficient pavement thickness for ramps, widenings, acceleration and deceleration lanes, and other miscellaneous areas are 500 ft. in length. Areas less than 500 ft. in length will be individually evaluated for payment adjustment based on the plan area.

- M. Ride Quality.** Unless otherwise shown on the plans, measure ride quality in accordance with Item 585, "Ride Quality for Pavement Surfaces."

360.5. Measurement. This Item will be measured as follows:

- A. Concrete Pavement.** Concrete pavement will be measured by the square yard of surface area in place. The surface area includes the portion of the pavement slab extending beneath the curb.
- B. Curb.** Curb on concrete pavement will be measured by the foot in place.

360.6. Payment. These prices are full compensation for materials, equipment, labor, tools, and incidentals.

361.1 to 361.2

- A. Concrete Pavement.** The work performed and materials furnished in accordance with this Item and measured as provided under “Measurement” will be paid for at the adjusted unit price bid for “Concrete Pavement” of the type and depth specified as adjusted in accordance with Section 360.6.B, “Deficient Thickness Adjustment.”
- B. Deficient Thickness Adjustment.** Where the average thickness of pavement is deficient in thickness by more than 0.2 in. but not more than 0.75 in., payment will be made using the adjustment factor as specified in Table 2 applied to the bid price for the deficient area for each unit as defined under Section 360.4.L.3, “Pavement Units for Payment Adjustment.”

Table 2
Deficient Thickness Price Adjustment Factor

Deficiency in Thickness Determined by Cores (in.)	Proportional Part of Contract Price Allowed (adjustment factor)
Not deficient	1.00
Over 0.00 through 0.20	1.00
Over 0.20 through 0.30	0.80
Over 0.30 through 0.40	0.72
Over 0.40 through 0.50	0.68
Over 0.50 through 0.75	0.57

- C. Curb.** Work performed and furnished in accordance with this Item and measured as provided under “Measurement” will be paid for at the unit price bid for “Curb” of the type specified.

ITEM 361

FULL-DEPTH REPAIR OF CONCRETE PAVEMENT

361.1. Description. Repair concrete pavement to full depth.

361.2. Materials. Provide materials that meet the pertinent requirements of the following:

- Item 360, “Concrete Pavement”
 - Item 421, “Hydraulic Cement Concrete”
 - Item 440, “Reinforcing Steel”
 - DMS 6100, “Epoxies and Adhesives.”
- A. Hydraulic Cement Concrete for Pavement.** If the time frame designated for opening to traffic is less than 72 hr. after concrete placement, provide Class HES concrete designed to attain a minimum average flexural strength of 255 psi or a minimum average compressive

strength of 1,800 psi within the designated time frame. Otherwise provide Class P concrete conforming to Item 360, "Concrete Pavement." Type III cement is permitted for Class HES concrete.

- B. Base Material.** Unless otherwise shown on the plans or permitted, furnish pavement concrete for replacement base material when required. The Engineer may waive quality control tests for base material.
- C. Asphalt Concrete.** Furnish asphalt concrete material for overlay and asphalt shoulder repair in accordance with Item 340, "Dense-Graded Hot-Mix Asphalt (Method)," as shown on the plans. The Engineer may waive quality control tests for this material.

361.3. Construction. Repair areas identified by the Engineer. Make repair areas rectangular, at least 6 ft. long and at least 1/2 a full lane in width unless otherwise shown on the plans. Unless otherwise shown on the plans, accept ownership of all removed material, and dispose of it in accordance with federal, state, and local regulations. Saw-cut and remove existing asphalt concrete overlay over the repair area and at least 6 in. outside each end of the repair area. Saw-cut full depth through the concrete around the perimeter of the repair area before removal. Do not spall or fracture concrete adjacent to the repair area. Schedule work so that concrete placement follows full-depth saw cutting by no more than 7 days unless otherwise shown on the plans or approved.

Remove or repair loose or damaged base material, and replace or repair it with approved base material to the original top of base grade. Place a polyethylene sheet at least 4 mils thick as a bond breaker at the interface of the base and new pavement. Allow concrete used as base material to attain sufficient strength to prevent displacement when placing pavement concrete.

Use only drilling operations that do not damage the surrounding operations. Place new deformed reinforcing steel bars of the same size and spacing as the bars removed or as shown on the plans. Lap all reinforcing steel splices in accordance with Item 440, "Reinforcing Steel." Place dowel bars and tiebars as shown on the plans. Epoxy-grout all tiebars for at least a 12-in. embedment into existing concrete. Completely fill the tiebar hole with Type III, Class A or Class C epoxy before inserting the tiebar into the hole. Provide grout retention disks for all tiebar holes. Provide and place approved supports to firmly hold the new reinforcing steel, tiebars, and dowel bars in place. Demonstrate, through simulated job conditions, that the bond strength of the epoxy-grouted tiebars meets a pullout strength of at

361.4 to 368.2

least 3/4 of the yield strength of the tiebar when tested in accordance with ASTM E 488 within 18 hr. after grouting. Increase embedment depth and retest when necessary to meet testing requirements. Perform tiebar testing before starting repair work.

Mix, place, cure, and test concrete to the requirements of Item 360, "Concrete Pavement," and Item 421, "Hydraulic Cement Concrete." Broom-finish the concrete surface unless otherwise shown on the plans. Match the grade and alignment of existing concrete pavement. After concrete strength requirements have been met, replace any asphalt overlay and shoulder material removed with new asphalt concrete material in accordance with Item 340, "Dense-Graded Hot-Mix Asphalt (Method)."

For repair areas to be opened to traffic before 72 hr., use curing mats to maintain a minimum concrete surface temperature of 70°F when air temperature is less than 70°F. Cure repaired area for at least 72 hr. or until overlaid with asphalt concrete, if required, or until the area is opened to traffic. Saw and seal contraction joints in the repair area in accordance with Item 360, "Concrete Pavement." Remove repair area debris from the right of way each day.

361.4. Measurement. This Item will be measured by the square yard of concrete surface area repaired. No measurement will be made for areas damaged because of Contractor negligence.

361.5. Payment. The work performed and the materials furnished in accordance with this Item and measured as specified under "Measurement" will be paid for at the unit price bid for "Full-Depth Repair" of the type and depth specified. This price is full compensation for removal, stockpiling, and disposal of waste material and for equipment, materials, labor, tools, and incidentals. Asphalt concrete, base material, and curbing will not be paid for directly but will be considered subsidiary to this Item.

ITEM 368

CONCRETE PAVEMENT TERMINALS

368.1. Description. Construct terminals for concrete pavement.

368.2. Materials. Furnish materials conforming to the following:

- Item 360, "Concrete Pavement"
- Item 421, "Hydraulic Cement Concrete"
- Item 440, "Reinforcing Steel"
- Item 442, "Metal for Structures."

Use ASTM A 36 steel for wide-flange structural steel. Shop-fabricate wide-flange beams in accordance with the plans. Unless otherwise shown on the plans, wide-flange beams are not required to be welded or spliced at longitudinal construction joints.

368.3. Construction. Construct concrete pavement terminals in accordance with the plans.

- A. Excavation, Backfilling, and Base Preparation.** Excavate and backfill in accordance with Item 400, “Excavation and Backfill for Structures,” and the plans. Avoid over-excavation. Restore subgrade and base layers damaged by excavation. Construct subgrade, base, and pavement layers in accordance with the plans.
- B. Reinforcement and Structural Steel.** Secure reinforcement in position before concrete placement in accordance with Item 440, “Reinforcing Steel,” and the plans. Accurately secure wide-flange beams in position in accordance with the plans and with sufficient supports to safely maintain alignment during concrete placement and finishing.
- C. Concrete Placement and Finishing.** Use Class P hydraulic cement concrete. Place hydraulic concrete pavement in accordance with Item 360, “Concrete Pavement.” Place bridge approach slabs in accordance with Item 420, “Concrete Structures.”
- D. Opening to Traffic.** Open concrete pavement terminal to traffic in conformance with Item 360, “Concrete Pavement.”

368.4. Measurement. This Item will be measured by the foot of concrete pavement terminal complete in place. Measurement will be made perpendicular to the direction of the flow of traffic.

This is a plans quantity measurement Item. The quantity to be paid is the quantity shown in the proposal, unless modified by Article 9.2, “Plans Quantity Measurement.” Additional measurement or calculations will be made if adjustments of quantities are required.

368.5. Payment. The work performed and the materials furnished in accordance with this Item and measured as specified under “Measurement” will be paid for at the unit price bid for “Wide Flange Pavement Terminals” or “Anchor Lugs Pavement Terminals.”

This price is full compensation for excavation, disposal of waste material, backfilling, hydraulic cement concrete (sleeper slab) underneath the concrete pavement, joint material, reinforcing steel, wide-flange beams, equipment, materials, labor, tools, and incidentals.

368.5 to 368.5

Subgrade treatment, asphalt concrete, base material, and curbing required by the plans will be measured and paid for in accordance with pertinent Items. Concrete pavement constructed as part of the concrete pavement terminal will be paid for under Item 360, "Concrete Pavement." Bridge approach slabs, including support slabs, will be paid for under Item 420, "Concrete Structures."

400 ITEMS — STRUCTURES

ITEM 400

EXCAVATION AND BACKFILL FOR STRUCTURES

400.1. Description. Excavate for placement and construction of structures and backfill structures. Cut and restore pavement.

400.2. Materials. Use materials that meet the requirements of the following Items:

- Item 401, “Flowable Backfill”
- Item 421, “Hydraulic Cement Concrete”
- DMS-4600, “Hydraulic Cement.”

400.3. Construction.

A. Excavation.

1. **General.** Excavate to the lines and grades shown on the plans or as directed. Provide slopes, benching, sheeting, bracing, pumping, and bailing as necessary to maintain the stability and safety of excavations up to 5 ft. deep. Excavation protection for excavations deeper than 5 ft. are governed by Item 402, “Trench Excavation Protection,” and Item 403, “Temporary Special Shoring.” Use satisfactory excavated material as backfill or as embankment fill in accordance with Item 132, “Embankment.” Dispose of material not incorporated into the final project off the right of way in accordance with federal, state, and local regulations.

When excavating for installation of structures across private property or beyond the limits of the embankment, keep any topsoil removed separate, and replace it, as nearly as feasible, in its original position. Restore the area to an acceptable condition.

Excavate drilled shafts in accordance with Item 416, “Drilled Shaft Foundations.”

- a. **Obstructions.** Remove obstructions to the proposed construction, including trees and other vegetation, debris, and structures, over the width of the excavation to a depth of 1 ft. below the bottom of excavation. If abandoned storm drains, sewers, or other drainage systems are encountered, remove as required to clear the new structure, and plug in an approved manner. After removing obstructions, restore the bottom of the

400.3 to 400.3

excavation to grade by backfilling in accordance with this Item. Dispose of surplus materials in accordance with federal, state, and local regulations.

- b. Excavation in Streets.** When structures are installed in streets, highways, or other paved areas, cut pavement and base to neat lines. Restore pavement structure after completion of excavation and backfilling.

Maintain and control traffic in accordance with the approved traffic control plan and the TMUTCD.

- c. Utilities.** Comply with the requirements of Article 7.12, "Responsibility for Damage Claims." Conduct work with minimum disturbance of existing utilities, and coordinate work in or near utilities with the utility owners. Inform utility owners sufficiently before work begins to allow them time to identify, locate, reroute, or make other adjustments to utility lines.

Avoid cutting or damaging underground utility lines that are to remain in place. If damage occurs, promptly notify the utility company. If an active sanitary sewer line is damaged during excavation, provide temporary flumes across the excavation while open, and restore the lines when backfilling has progressed to the original bedding lines of the cut sewer.

- d. De-Watering.** Do not construct or place structures in the presence of water unless approved. Place precast members, pipe, and concrete only on a dry, firm surface. Remove water by bailing, pumping, well-point installation, deep wells, underdrains, or other approved method.

If structures are approved for placement in the presence of water, remove standing water in a manner that does not allow water movement through or alongside concrete being placed. Do not pump or bail while placing structural concrete or for a period of at least 36 hr. thereafter unless from a suitable sump separated from the concrete work. Pump or bail during placement of seal concrete only to the extent necessary to maintain a static head of water within the cofferdam. Do not pump or bail to de-water inside a sealed cofferdam until the seal has aged at least 36 hr.

If the bottom of an excavation cannot be de-watered to the point that the subgrade is free of mud or it is difficult to keep

reinforcing steel clean, place a stabilizing material in the bottom of the excavation. Stabilizing material may be flexible base, cement-stabilized base or backfill, lean concrete, or other approved material. If lean concrete is used, provide concrete with at least 275 lb. of cement per cubic yard, and place to a minimum depth of 3 in. Stabilizing material placed for the convenience of the Contractor will be at the Contractor's expense.

2. **Bridge Foundations and Retaining Walls.** Do not disturb material below the bottom of footing grade. Do not backfill to compensate for excavation that has extended below grade. If excavation occurs below the proposed footing grade, fill the area with concrete at the time the footing is placed. The additional concrete placed will be at the Contractor's expense.

If requested, take cores to determine the character of the supporting materials. Provide an intact sample adequate to judge the character of the founding material. Take these cores when the excavation is close to completion. Cores should be approximately 5 ft. deeper than the proposed founding grade.

If the founding stratum is rock or other hard material, remove loose material, clean, and cut to a firm surface that is level, stepped, or serrated, as directed. Clean out soft seams, and fill with concrete at the time the footing is placed.

If the material at the footing grade of a retaining wall, bridge bent, or pier is a mixture of compressible and incompressible material, do not place the foundation until the Engineer has inspected the excavation and authorized changes have been made to provide a uniform bearing condition.

3. **Cofferdams.** The term "cofferdam" designates any temporary or removable structure constructed to hold surrounding earth, water, or both out of the excavation whether the structure is formed of soil, timber, steel, concrete, or a combination of these. Cofferdams may require the use of pumping wells or well points for de-watering.

For sheet-pile or other types of cofferdams requiring structural members, submit details and design calculations bearing the seal of a licensed professional engineer for review before constructing the cofferdam. The Department reserves the right to reject designs. Design structural systems to comply with the AASHTO *Standard Specifications for Highway Bridges* or AASHTO *LRFD Bridge*

Design Specifications. Interior dimensions of cofferdams must provide sufficient clearance for the construction, inspection, and removal of required forms and, if necessary, sufficient room to allow pumping outside the forms. In general, extend sheet-pile cofferdams well below the bottom of the footings, and make concrete seals as well braced and watertight as practicable.

For foundation seals, use Class E concrete unless otherwise specified. Place concrete foundation seals in accordance with Item 420, "Concrete Structures." Seals placed for the convenience of the Contractor will be at the Contractor's expense.

When the Engineer judges it to be impractical to de-water inside a cofferdam and a concrete seal is to be placed around piling driven within the cofferdam, make the excavation deep enough to allow for swelling of the material at the base of the excavation during pile-driving operations. After driving the piling, remove swelling material to the bottom of the seal grade. Where it is possible to de-water inside the cofferdam without placing a seal, remove the foundation material to exact footing grades after driving piling. Do not backfill a foundation to compensate for excavation that has been extended below grade; fill such areas below grade with concrete at the time the seals or footings are placed.

Unless otherwise provided, remove cofferdams after completing the substructure without disturbing or damaging the structure.

4. **Culverts and Storm Drains.** When the design requires special bedding conditions for culverts or storm drains, an excavation diagram will be shown on the plans. Do not exceed these limits of excavation.

Unless otherwise shown on the plans, construct pipe structures in an open cut with vertical sides extending to a point 1 ft. above the pipe. When site conditions or the plans do not prohibit sloping the cut, the excavation may be stepped or laid back to a stable slope beginning 1 ft. above the pipe. Maintain the stability of the excavation throughout the construction period.

For pipe to be installed in fill above natural ground, construct the embankment to an elevation at least 1 ft. above the top of the pipe, and then excavate for the pipe.

- a. **Unstable Material.** When unstable soil is encountered at established footing grade, remove the material to a depth of no more than 2 ft. below the grade of the structure unless the

Engineer authorizes additional depth. Replace soil removed with stable material in uniform layers at most 8 in. deep (loose measurement). Each layer must have enough moisture to be compacted by rolling or tamping as required to provide a stable foundation for the structure.

When it is not feasible to construct a stable foundation as outlined above, use special materials such as flexible base, cement-stabilized base, cement-stabilized backfill, or other approved material.

- b. Incompressible Material.** If rock, part rock, or other incompressible material is encountered at established footing grade while placing prefabricated elements, remove the incompressible material to 6 in. below the footing grade, backfill with an approved compressible material, and compact in accordance with Section 400.3.C, "Backfill."
- B. Shaping and Bedding.** For precast box sections, place at least 2 in. of fine granular material on the base of the excavation before placing the box sections. For pipe installations, use bedding as shown in Figure 1. Use Class C bedding unless otherwise shown on the plans. The Engineer may require the use of a template to secure reasonably accurate shaping of the foundation material. Where cement-stabilized backfill is indicated on the plans, undercut the excavation at least 4 in. and backfill with stabilized material to support the pipe or box at the required grade.

- B_c - Outside diameter or horizontal dimension
- D - Inside diameter of pipe
- d - Min. bedding material below pipe

D	d
$\leq 27''$	3"
30" to 60"	4"
$\geq 66''$	6"

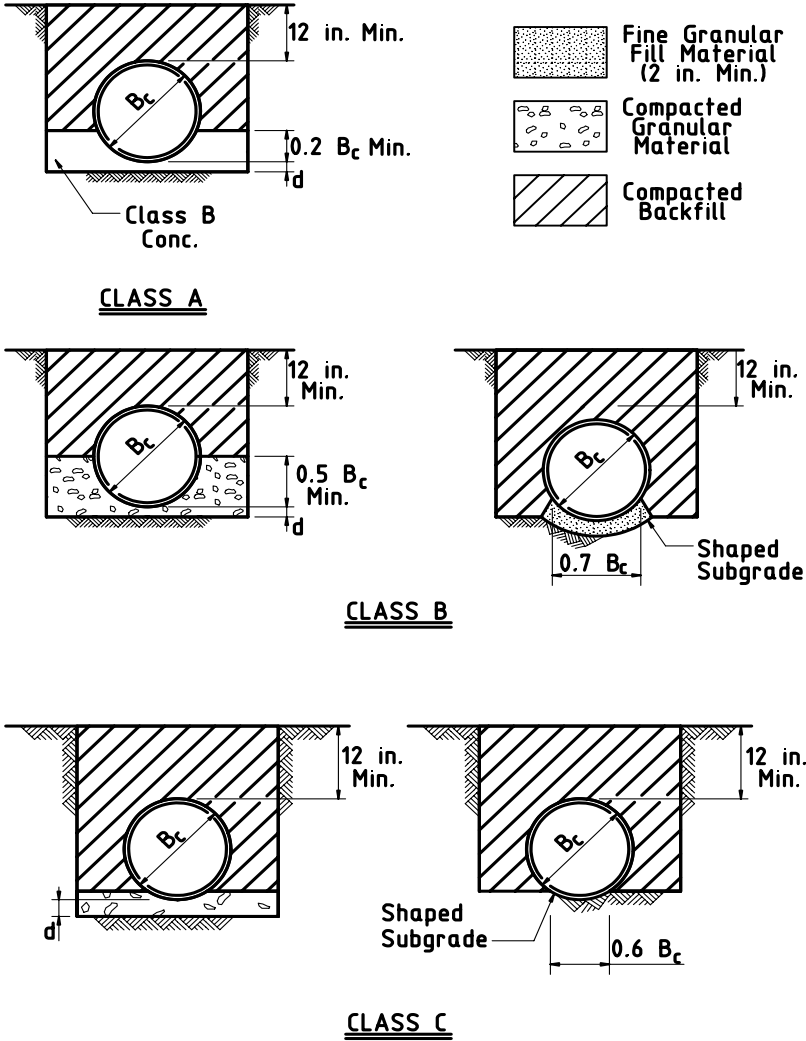

Figure 1
Bedding diagrams.

C. Backfill.

1. **General.** As soon as practical, backfill the excavation after placement of the permanent structure. Use backfill free from stones large enough to interfere with compaction; large or frozen lumps that will not break down readily under compaction; and wood or other extraneous material. Obtain backfill material from excavation or from other sources.

In areas not supporting a completed roadbed, retaining wall, or embankment, place backfill in layers at most 10 in. deep (loose measurement). In areas supporting a portion of a roadbed, retaining wall, or embankment, place backfill in uniform layers at most 8 in. deep (loose measurement). Compact each layer to meet the density requirements of the roadbed, retaining wall, embankment material, or as shown on the plans.

Bring each layer of backfill material to the moisture content needed to obtain the required density. Use mechanical tamps or rammers to compact the backfill. Rollers may be used to compact backfill if feasible.

Cohesionless materials such as sand may be used for backfilling. Compact cohesionless materials using vibratory equipment, water-pounding, or a combination of both.

2. **Bridge Foundations, Retaining Walls, and Box Culverts.** Do not place backfill against the structure until the concrete has reached the design strength required in Item 421, "Hydraulic Cement Concrete."

Backfill retaining walls with material meeting the requirements of Item 423, "Retaining Walls." Backfill around bridge foundations and culverts using material with no particles more than 4 in. in greatest dimension and with a gradation that permits thorough compaction. Rock or gravel mixed with soil may be used if the percentage of fines is sufficient to fill all voids and ensure a uniform and thoroughly compacted mass of proper density.

Where backfill material is being placed too close to the structure to permit compaction with blading and rolling equipment, use mechanical tamps and rammers to avoid damage to the structure.

Avoid wedging action of backfill against structures. To prevent such action, step or serrate slopes bounding the excavation. Place backfill uniformly around bridge foundations. Place backfill along both sides of culverts equally and in uniform layers.

400.3 to 400.3

The Engineer may require backfilling of structures excavated into hard, erosion-resistant material, and subject to erosive forces, with stone or lean concrete.

Box culverts may be opened to traffic as soon as sufficient backfill and embankment has been placed over the top to protect culverts against damage from heavy construction equipment. Repair damage to culvert caused by construction traffic at no additional expense to the Department.

- 3. Pipe.** After installing bedding and pipe as required, bring backfill material to the proper moisture condition and place it equally along both sides of the pipe in uniform layers at most 8 in. deep (loose measurement). Compact each lift mechanically. Thoroughly compact materials placed under the haunches of the pipe to prevent damage or displacement of the pipe. Continue to place backfill in this manner to the top-of-pipe elevation. Place and compact backfill above the top of the pipe in accordance with Section 400.3.C.1, "General."

The Engineer may reject backfill material containing more than 20% by weight of material retained on a 3-in. sieve; with large lumps not easily broken down; or that cannot be spread in loose layers. Material excavated by a trenching machine will generally meet the requirements of this Section as long as large stones are not present.

Where pipe extends beyond the toe of slope of the embankment and the depth of cover provided by backfill to the original ground level is less than the minimum required by the specifications for the type of pipe involved, place and compact additional material until the minimum cover has been provided.

- 4. Cement-Stabilized Backfill.** When shown on the plans, backfill the excavation to the elevations shown with cement-stabilized backfill. Use cement-stabilized backfill that contains aggregate, water, and a minimum of 7% hydraulic cement based on the dry weight of the aggregate, in accordance with Tex-120-E. Use clean sand as aggregate for cement-stabilized backfill unless otherwise shown on the plans. Use only approved aggregate.

Place cement-stabilized backfill equally along the sides of structures to prevent strain on or displacement of the structure. Fill voids when placing cement-stabilized backfill. Use hand operated tampers if necessary to fill voids.

5. **Flowable Backfill.** When shown on the plans, backfill the excavation with flowable backfill to the elevations shown. Prevent the structure from being displaced during the placement of the flowable fill, and prevent flowable fill from entering culverts and drainage structures.

400.4. Measurement. This is a plans quantity measurement Item. The quantity to be paid is the quantity shown in the proposal, unless modified by Article 9.2, "Plans Quantity Measurement." Additional measurements or calculations will be made if adjustments of quantities are required.

- A. **Structural Excavation.** Unless shown on the plans as a pay item, structural excavation quantities shown are for information purposes only.

When structural excavation is specified as a pay item, structural excavation for pipe headwalls, inlets, manholes, culvert or storm drain extensions less than 15 ft. long, bridge abutments, retaining walls, and side road and private entrance pipe culverts will not be measured. No allowance will be made for variance from plans quantity incurred by an alternate bid.

When specified as a pay item, structural excavation will be measured by the cubic yard as computed by the average end areas method. Excavation diagrams on the plans take precedence over the provisions of this Article.

1. **Boundaries of Measurement.**

- a. **Pipe.**

- (1) **Pipe up to 42 Inches.** For pipe 42 in. or less in nominal or equivalent diameter, no material outside of vertical planes 1 ft. beyond and parallel to the horizontal projection of the outside surfaces of the pipe will be included.
- (2) **Pipe Larger than 42 Inches.** For pipes larger than 42-in. nominal or equivalent diameter, no material outside of vertical planes located 2 ft. beyond and parallel to the horizontal projection of the outside surfaces of the pipe will be included.

Quantities for excavation in fill above natural ground include 1 ft. above the top of the pipe regardless of the height of completed fill. Excavation for pipe will be measured between the extreme ends of the completed

400.4 to 400.4

structure including end appurtenances as shown on the plans and from centerline to centerline of inlets, manholes, etc.

- b. Structural Plate Structures.** No material outside of vertical planes 3 ft. beyond and parallel to the horizontal projection of the outside surfaces of the structure will be included. When the quality of the existing soil or embankment is less than that of the proposed backfill material, the limits of measurement will be extended to vertical planes located 1/2 of the span beyond the horizontal projection of the outside surfaces of the structure.
- c. Footings, Walls, Boxes, and Other Excavation.** No material outside of vertical planes 1 ft. beyond and parallel to the edges of the footings or outside walls will be included whether or not a cofferdam or shoring is used. When plans provide the option of cast-in-place or precast boxes, measurement will be based on the cast-in-place option.

Where excavation in addition to that allowed for the footings is required for other portions of the structure, measurement for the additional excavation will be limited laterally by vertical planes 1 ft. beyond the face of the member and parallel to it, and vertically to a depth of 1 ft. below the bottom of the member.

- d. Excavation near Roadways and Channels.** At structure sites other than culverts and pipe excavations, the measurement of structural excavation will include only material below or outside the limits of the completed road or channel excavation. Roadway and channel excavation will be paid under Item 110, "Excavation." For culverts except side road and private entrance culverts, excavation within the limits of the structure and below or outside the limits of the completed roadway excavation will be measured as structural excavation.
- 2. Falsework.** No measurement will be made for excavation necessary for placing forms or falsework that exceeds the limits given in Section 400.4.B.1, "Boundaries of Measurement."
 - 3. Swelling.** Measurement will not include materials removed below footing grades to compensate for anticipated swelling due to pile driving, nor will it include material required to be removed due to swelling beyond the specified limits during pile driving operations.

4. **Cave-ins.** Measurement will not include additional volume caused by slips, slides, cave-ins, silting, or fill material resulting from the action of the elements or the Contractor's operation.
 5. **Undercut.** Where rock or other incompressible or unstable material is undercut to provide a suitable foundation for pipe or box sections, such material below grade directed to be removed will be measured for payment.
 6. **Grade Change.** Additional measurement will be made of the volume of excavation involved in the lowering or raising of the elevation of a footing, foundation, or structure unit, when such grade change is authorized.
- B. Cement-Stabilized Backfill.** Cement-stabilized backfill will be measured by the cubic yard as shown on the plans.
- C. Cutting and Restoring Pavement.** Cutting and restoring pavement will be measured by the square yard as shown on the plans. Excavation below pavement or base will be measured as structural excavation of the pertinent type.

400.5. Payment.

- A. Structural Excavation.** Unless specified as a pay item, structural excavation and backfill performed and material furnished in accordance with this Item will not be paid for directly but are subsidiary to pertinent Items.

When structural excavation is specified as a pay item, the excavation and backfill work performed and materials furnished will be paid for at the unit price bid for "Structural Excavation," "Structural Excavation (Box)," "Structural Excavation (Pipe)," and "Structural Excavation (Bridge)." This price includes concrete to compensate for excavation that has extended below grade for bridge foundations and retaining walls, and backfilling and compacting areas that were removed as part of structural excavation.

Cofferdams or other measures necessary for supporting excavations less than 5 ft. deep will not be measured or paid for directly but will be subsidiary to the Contract.

Foundation seal concrete for cofferdams, when required by the Engineer, will be paid for as provided in the pertinent Items. If no direct method of payment is provided in the Contract, the work will be measured and paid for in accordance with Article 9.4, "Payment for

400.5 to 400.5

Extra Work.” Seal placed for the convenience of the Contractor will not be paid for.

Unless otherwise provided, stone or lean concrete backfill around structures as provided for in Section 400.3.C.2, “Bridge Foundations, Retaining Walls, and Culverts,” will be measured and paid for as extra work in accordance with Article 9.4.

When structural excavation is specified as a pay item, a partial payment of 50% of the bid price will be made for structural excavation completed to the satisfaction of the Engineer but not backfilled. The remaining amount will be paid upon completion of backfilling. When the Contractor elects to excavate beyond plan requirements, no measurement will be made of the additional volume.

B. Removal and Replacement of Unsuitable or Incompressible

Material. Removal and replacement of material will be paid for if directed. Removal and replacement of material or placement of special material made necessary by the softening of founding material due to the Contractor’s sequence of work or operation, will be at the Contractor’s expense. Special material used or additional excavation made for the Contractor’s convenience will not be paid for.

1. Structural Excavation as a Pay Item. Where special materials are not required or specified, payment for the removal and replacement of unstable or incompressible material will be made at a price equal to 200% of the unit price bid per cubic yard for Structural Excavation. When the Contractor elects to remove and replace material deeper than directed, no measurement will be made on that portion below the directed elevation. This price is full compensation for removing the unstable or incompressible material; furnishing, hauling, placing, and compacting suitable replacement material; and equipment, labor, tools, and incidentals.

When the plans specify or when the Engineer directs the use of special materials such as flexible base, cement-stabilized base, cement-stabilized backfill, or other special material, payment for excavation below footing grades will be made at the unit price bid for Structural Excavation. Payment for furnishing, hauling, placing, and compacting the flexible base, cement-stabilized base, cement-stabilized backfill, or other special materials will be made at the unit price bid for these items in the Contract, or, if the required material is not a bid item, in accordance with Article 9.4, “Payment for Extra Work.”

- 2. Structural Excavation Not a Pay Item.** Where special materials for backfill are not required or specified, payment for the authorized removal and replacement of unstable or incompressible material will be measured and paid for at \$15 per cubic yard of material removed. This price is full compensation for removing the unstable or incompressible material; furnishing, hauling, placing, and compacting suitable replacement material; and equipment, labor, tools, and incidentals.

When the plans specify or when the Engineer directs the use of special materials such as flexible base, cement-stabilized base, cement-stabilized backfill, or other special material, excavation below the footing grades will be paid for at \$10 per cubic yard. Payment for furnishing, hauling, placing, and compacting the flexible base, cement-stabilized base, cement-stabilized backfill, or other special materials will be made at the unit price bid for these Items, or, if the required material is not a bid Item, in accordance with Article 9.4, "Payment for Extra Work."

- C. Lowering of a Structure Foundation.** If the Engineer requires a structure foundation to be lowered to an elevation below the grade shown on the plans, overexcavation will be paid in accordance with Table 1.

**Table 1
Payment for Required Overexcavation**

Variance of revised footing grade from plan grade	Payment terms	Variance of revised footing grade from plan grade
	"Structural Excavation" is a bid item	"Structural Excavation" is not a bid item
Up to and including 5 ft.	Unit price equal to 115% of unit price bid for "Structural Excavation"	\$10 per cubic yard
Over 5 ft. up to 10 ft.	Unit price equal to 125% of unit price bid for "Structural Excavation"	\$12 per cubic yard
Over 10 ft.	In accordance with Article 9.4, "Payment for Extra Work"	

- D. Cement-Stabilized Backfill.** Cement-stabilized backfill will be paid for at the unit price bid for "Cement Stabilized Backfill."

401.1 to 401.2

- E. Cutting and Restoring Pavement.** Cutting and restoring pavement will be paid for at the unit price bid for “Cutting and Restoring Pavement.” Work done to repair damage to base or pavement incurred outside the limits shown on the plans, or the limits authorized by the Engineer, will not be measured for payment.

The unit prices bid are full compensation for excavation including removing obstructions and plugging drainage systems; bedding and backfilling including placing, sprinkling and compaction of material; soundings; cleaning and filling seams; constructing and removing cofferdams; de-watering, sheeting, or bracing excavations up to and including 5 ft. deep; pumps; drills; explosives; disposition of surplus material; cutting pavement and base to neat lines; and materials, hauling, equipment, labor, tools, and incidentals.

Flowable backfill will be paid for as provided in Item 401, “Flowable Backfill.” Protection methods for open excavations deeper than 5 ft. will be measured and paid for as required under Item 402, “Trench Excavation Protection,” or Item 403, “Temporary Special Shoring.”

ITEM 401

FLOWABLE BACKFILL

401.1. Description. Furnish and place flowable backfill for trench, hole, or other void.

401.2. Materials.

- A. Cement.** Furnish cement conforming to DMS-4600, “Hydraulic Cement.”
- B. Fly Ash.** Furnish fly ash conforming to DMS-4610, “Fly Ash.”
- C. Chemical Admixtures.** Furnish chemical admixtures conforming to DMS-4640, “Chemical Admixtures for Concrete.”
- D. Fine Aggregate.** Provide fine aggregate that will stay in suspension in the mortar to the extent required for proper flow and that meets the gradation requirements of Table 1.

Table 1
Aggregate Gradation Chart

Sieve Size	Percent Passing
3/4 in.	100
No. 200	0–30

Test fine aggregate gradation in accordance with Tex-401-A.

Plasticity Index (PI) must not exceed 6 when tested in accordance with Tex-106-A.

- E. Mixing Water.** Use mixing water conforming to the requirements of Item 421, “Hydraulic Cement Concrete.”

401.3. Construction. Submit a construction method and plan, including mix design and shrinkage characteristics of the mix, for approval. Provide a means of filling the entire void area, and be able to demonstrate that this has been accomplished. Prevent the movement of any inserted structure from its designated location. If voids are found in the fill or if any of the requirements are not met as shown on the plans, remove and replace or correct the problem without additional cost to the Department.

Unless otherwise shown on the plans, furnish a mix meeting the requirements of Sections 401.3.A, “Strength,” and 401.3.B, “Consistency.”

- A. Strength.** The 28-day compressive strength range, when tested in accordance with Tex-418-A, must be between 80 psi and 150 psi unless otherwise directed. Two specimens are required for a strength test, and the compressive strength is defined as the average of the breaking strength of the 2 cylinders.
- B. Consistency.** Design the mix to be placed without consolidation and to fill all intended voids. Fill an open-ended, 3-in.-diameter-by-6-in.-high cylinder to the top to test the consistency. Immediately pull the cylinder straight up. The correct consistency of the mix must produce a minimum 8-in.-diameter circular spread with no segregation.

When necessary, use specialty type admixtures to enhance the flowability, reduce shrinkage, and reduce segregation by maintaining solids in suspension. All admixtures must be used and proportioned in accordance with the manufacturer’s recommendations.

Mix the flowable fill using a central-mixed concrete plant, ready-mix concrete truck, pug mill, or other approved method.

Furnish all labor, equipment, tools, containers, and molds required for sampling, making, transporting, curing, removal, and disposal of test

401.4 to 402.4

specimens. Furnish test molds meeting the requirements of Tex-447-A. Transport, strip, and cure the test specimens as scheduled at the designated location. Cure test specimens in accordance with Tex-447-A. The Engineer will sample, make, and test all specimens. Dispose of used, broken specimens in an approved location and manner. The frequency of job control testing will be at the direction of the Engineer.

401.4. Measurement. This Item will be measured by the cubic yard of material placed. Measurement will not include additional volume caused by slips, slides, or cave-ins resulting from the Contractor's operations.

401.5. Payment. The work performed and materials furnished in accordance with this Item and measured as provided under "Measurement" will be paid for at the unit price bid for "Flowable Backfill." This price is full compensation for furnishing, hauling, and placing materials and for equipment, tools, labor, and incidentals.

ITEM 402

TRENCH EXCAVATION PROTECTION

402.1. Description. Furnish and place excavation protection for trenches deeper than 5 ft.

402.2. Construction. Provide vertical or sloped cuts, benches, shields, support systems, or other systems providing the necessary protection in accordance with OSHA Standards and Interpretations, 29 CFR 1926, Subpart P, "Excavations."

402.3. Measurement. This Item will be measured by the foot along the long axis of the trench where the depth of trench exceeds 5 ft. This measurement includes all required trench protection, including trench ends.

402.4. Payment. The work performed and materials furnished in accordance with this Item and measured as provided under "Measurement" will be paid for at the unit price bid for "Trench Excavation Protection." This price is full compensation for excavation and backfill required for excavation protection; furnishing, placing, and removing shoring, sheeting, or bracing; dewatering or diversion of water; jacking and jack removal; and equipment, labor, materials, tools, and incidentals.

ITEM 403

TEMPORARY SPECIAL SHORING

403.1. Description. Furnish and install temporary shoring to hold the surrounding earth, water, or both out of the work area.

403.2. Materials. Furnish new or used materials. When using temporary mechanically stabilized earth (MSE) walls, furnish materials that comply with the requirements of Item 423, “Retaining Walls.”

403.3. Construction. Unless complete details are included in the plans, the Contractor is responsible for the temporary special shoring design. Submit details and design calculations bearing the seal of a licensed professional engineer before constructing the shoring. The Department reserves the right to reject designs. Design the shoring to comply with OSHA Standards and Interpretations, 29 CFR 1926, Subpart P, “Excavations.” Design structural systems to comply with AASHTO *Standard Specifications for Highway Bridges* or AASHTO *LRFD Bridge Design Specifications*. Design shoring subject to railroad loading to comply with the AREMA *Manual for Railway Engineering* and any additional requirements of the railway being supported.

Provide vertical or sloped cuts, benches, shields, support systems, or other systems to provide the necessary protection in accordance with the approved design. Construct temporary MSE walls, when used, in accordance with the requirements of Item 423, “Retaining Walls.”

403.4. Measurement. This Item will be measured by the square foot of surface area of a vertical plane at the face of the shoring between the top of the ground being supported and the minimum protection grade line shown on the plans. If no minimum protection grade is shown on the plans, the lowest required excavated elevation will be used. Shoring projecting above the level of the ground being supported will not be measured. When excavation techniques (e.g., sloped cuts or benching) are used to provide the necessary protection, the surface area for payment will be calculated based on the area described by a vertical plane adjacent to the structure.

403.5. Payment. The work performed and materials furnished in accordance with this Item and measured as provided under “Measurement” will be paid for at the unit price bid for “Temporary Special Shoring.” This price is full compensation for excavation and backfill; furnishing, placing and removing shoring, sheeting, or bracing; dewatering or diversion of

403.5 to 404.2

water; jacking and jack removal; and equipment, labor, materials, tools, and incidentals.

No payment will be made for special shoring made necessary by the selection of an optional design or sequence of work that creates the need for shoring.

ITEM 404 DRIVING PILING

404.1. Description. Drive piling.

404.2. Equipment.

A. Driving Equipment. Use power hammers for driving piling with specified bearing resistance. Use power hammers that comply with Table 1. Gravity hammers may be used for driving sheet piling and timber piling if no required design load is shown on the plans.

For initial rating of diesel hammers to determine compliance with the requirements of Table 1, the height of fall of the ram of the single-acting (open-end) hammer must be 7 ft. For a double-acting (enclosed ram) hammer, the energy rating must be 85% of the rated output by the manufacturer.

A hammer that produces less energy than required by Table 1 may be approved if a wave equation analysis indicates that the hammer can drive the specified pile against a bearing resistance of 3 times the required design load before reaching 0.1 in. of penetration per blow. The bearing resistance of the piling driven with this particular equipment will be determined in accordance with the Wave Equation Method.

Use an air compressor that supplies the volume and pressure specified by the manufacturer of the hammer. Provide an accurate pressure gauge.

Maintain the valve mechanism and other parts of power hammers so that the hammer will operate at the speed and stroke length specified by the manufacturer.

Equip enclosed ram diesel hammers with a gauge and provide charts to evaluate the equivalent energy being produced. Calibrate the gauge before work begins, whenever gauge accuracy is in question, and at least once each 6 months.

Table 1
Size of Driving Equipment

Piling Type	Hammer Type	Ram Weight (lb.)	Maximum Ram Stroke (ft.)	Minimum Hammer Energy (ft.-lb.)¹
Timber	Air, Hydraulic	2,000 min.	5	330R
	Diesel	2,000 min.	10	330R
Steel	Air, Hydraulic	3,000 min.	5	Larger of 250R or 2-1/2 Wp
	Diesel	2,000 min.	10	Larger of 250R or 2-1/2 Wp
Concrete	Air, Hydraulic	3,000 min., but not less than 1/4 Wp	5	250R, but not less than 1 ft.-lb. per lb. of pile weight
	Diesel	2,700 min., but not less than 1/4 Wp	8 ²	250R, but not less than 1 ft.-lb. per lb. of pile weight

1. R = Design load in tons. Wp = Weight of pile in pounds based on plan length.

2. Diesel hammers with less ram weight or greater ram stroke are permitted if a wave equation analysis indicates that the combination of ram weight, stroke, and cushioning will not overstress the piling.

Cap block cushioning material, when used between the ram and anvil or follow block, must consist of layers of micarta plastic and aluminum or other material specifically produced and approved for this application.

When using gravity hammers, regulate the height of fall to avoid damage to the piling.

Drive all test piling in a structure or in any approved segment of it with the same hammer, and use the same type and size hammer to drive the remainder of the piling in the structure or segment.

Equip pile drivers with leads constructed to allow freedom of movement of the hammer and to provide adequate support to the pile during driving. The longitudinal axis of the leads, hammer, and pile should coincide.

404.3 to 404.3

Except where piling is driven through water, ensure that leads are long enough that a follower will not be necessary. Where a follower is required when driving piling underwater, use 1 pile in each 10 that is long enough to permit driving without a follower. Drive it as a test pile for proper correlation of the follower-driven piling. Payment will be made as regular piling.

Hammers designed to operate underwater may be used for underwater driving without a follower and without the correlation required for other hammers.

- B. Protection of Pile Heads.** Use a steel driving head (helmet) suitable for the type and size of piling. Drive steel H-piling and sheet piling with a helmet compatible with the specific pile shape driven.

For concrete piling, provide a cushion block between the driving head and the top of the pile. Unless otherwise directed, use a cushion block that is a minimum of 4 in. thick for short piling (50 ft. or less) and at least 6 in. thick for longer piling. Use multiple layers of one of the following:

- 3/4-in. or 1-in. structural grade southern pine or fir plywood;
- green oak or gum, with the grain of the wood horizontal; or
- other approved material specifically produced for this application.

Pay special attention to the condition of the cushioning material. Do not drive more than 3 piles with one cushion block. Change cushioning more frequently if necessary to prevent damage. Immediately replace any cushion block that has ignited. Do not use a tight-fitting driving helmet for concrete piling. Allow room for slight movement, but ensure that the driving helmet is not large enough for the pile head to rotate freely. Center concrete piling and cushion within the helmet throughout the driving operation.

404.3. Construction. This Item uses the following terms:

- Foundation piling – Piling placed under interior bent footings or retaining wall abutment footings.
- Trestle piling – Piling embedded directly into the abutment cap or interior bent cap.
- Sheet piling – Retaining piling not considered either foundation or trestle piling.
- Test piling – Specific piling driven to investigate site conditions and determine regular piling lengths.

- Test-loaded piling – Specific piling driven and test-loaded to investigate site conditions and determine regular piling lengths. Do not fabricate regular piling until test loading and analysis is completed.
- Regular piling – All piling other than test piling and test-loaded piling.

Do not fabricate regular piling until test pile driving and analysis or test loading and analysis is completed.

Complete the embankment at bridge ends before driving abutment piling. Refer to Item 423, “Retaining Walls,” for provisions on piling that passes through the structural volume of retaining walls.

Do not drive foundation piling until the footing excavation is approximately complete. Do not drive concrete piling until the piling concrete, including build-ups, has aged at least 14 days. Do not drive piling in a saltwater environment until the piling concrete, including build-ups, has aged at least 21 days after concrete placement.

Re-drive any piling that is raised when driving adjacent piling. Withdraw and replace any broken, split, or displaced piling, or correct it as directed after a design analysis.

To control excessive stresses resulting in damage to the piling during driving, the following, alone or in combination, may be required:

- increase in cushion thickness,
- reduction of ram stroke,
- heavier ram with a shorter stroke,
- use of pilot holes or jetting when driving through hard or alternating hard and soft strata.

A. Tolerance for Driving. Drive piling to the required vertical or batter alignment, within the tolerances of this Section. Drive piling in pilot holes or with templates when necessary to comply with tolerances. Cut off piling reasonably square at the elevation shown on the plans, with a tolerance of not more than 2 in. above or below established cutoff grade. When tolerances are exceeded and the Engineer requires corrective action, submit for approval a structural analysis and proposed corrective action, signed and sealed by a licensed professional engineer.

1. Trestle Piling.

- Transverse to the centerline of the bent, the top of the piling may be at most 2 in. from the position shown on the plans.
- Parallel to the centerline of the bent, the top of the piling may be at most 4 in. from the position shown on the plans.

2. Foundation Piling.

- The top of each pile may be at most 4 in. in any direction from the position shown on the plans.
- The center of gravity of the piling group may be at most 3 in. from the center of gravity determined from plan location.
- The minimum edge distance for piling in a footing is 5 in. Additional concrete required to obtain this edge distance and specified reinforcing steel cover will be at the Contractor's expense.

B. Penetration. Piling lengths shown on the plans are the lengths estimated to give required bearing and are for estimating purposes only. Drive piling to within 5 ft. of plan length and to greater depths as necessary to obtain the required bearing resistance shown on the plans, unless other penetration requirements or bearing evaluation methods govern.

When test piling or test loaded piling is used, the Engineer will establish regular pile lengths on the basis of the test data. In these cases, drive regular piling to this approximate elevation and to greater depths as required to obtain the required bearing resistance.

For unusually hard driving conditions, typically less than 0.1 in. of penetration per blow, provide either pilot holes or jetting or a combination of both if plan penetration is not obtained. Penetration may be reduced upon approval if stability requirements are met.

C. Pilot Holes. Except as specified, do not extend pilot holes more than 5 ft. below the bottom of footings for foundation piling or 10 ft. below finished ground line for trestle piling, unless the specified penetration cannot be obtained by using the depth of holes indicated. When deeper pilot holes are required, determine their size and depth from the results of trial operations on the first piling driven or from available test pile data. Obtain approval for any excess depth or size of pilot holes. The maximum hole diameter permitted will be approximately 4 in. less than the diagonal of square piling or steel H-piling and 1 in. less than the diameter of round piling. The Engineer may vary hole size and depth to obtain penetration and bearing resistance.

Extend pilot holes through all embankments to natural ground when driving concrete piling.

Where a pilot hole is required in granular material that cannot be sealed off by ordinary drilling methods, a casing may be required around the boring device deep enough to prevent loose material from falling into the pilot hole.

Drive the piling below the depth of the pilot hole a minimum of 1 ft. or 100 blows but not less than the required bearing resistance shown on the plans. Unless directed otherwise, do not drive piling beyond the point where the penetration per blow is less than 0.1 in. as determined by an average of 10 blows. If damage to the pile is apparent, stop driving.

- D. Jetting.** Jetting is permitted when the specified penetration cannot be obtained by driving and pilot holes or other methods are not feasible. Before jetting, submit details of the proposed methods for approval. The Engineer may authorize varying depths of jetting to achieve the desired results.

Jet as required in conjunction with driving but only to the approved depth. For jetting operations, use enough power to simultaneously operate at least two 2-1/2-in. diameter pipes equipped with 3/4-in. nozzles at a pressure of 150 psi. Perform the jetting with 1 or 2 jets as determined and approved from results of trial operations.

Drive the piling below the depth of the jetting a minimum of 1 ft. or 100 blows but not less than the required bearing resistance shown on the plans. Unless directed otherwise, do not drive piling beyond the point where the penetration per blow is less than 0.1 in. as determined by an average of 10 blows. If damage to the pile is apparent, stop driving.

- E. Hammer Formula Method of Bearing Evaluation.** Unless otherwise shown on the plans, determine the dynamic bearing resistance of piling by one of the hammer formulas in this Section. If the Engineer has determined a K factor based on test piling, test-loaded piling, or other methods, the computed resistance will be the driving resistance determined based on the appropriate formula multiplied by the K factor.

- 1. Single-Acting Power Hammers.** Use the following formula:

$$P = \frac{2WH}{S + 0.1}$$

where:

P = dynamic resistance in pounds.

W = weight of ram in pounds.

H = height of fall of ram in feet.

S = average penetration in inches per blow for the last 20 blows.

404.3 to 404.3

Determine H by visual observation of the ram against a calibrated rod mounted on the hammer, by an approved stroke indicator and blow count logging device, or by the following formula:

$$H = 16.1 \times \left(\frac{30}{B} \right)^2 - 0.3$$

where B = blows per minute.

2. **Double-Acting Power Hammers.** Use the following formula:

$$P = \frac{2E}{S + 0.1}$$

where:

P = dynamic resistance in pounds

E = manufacturer's rated energy in foot-pounds (for double-acting power hammers), or the equivalent energy in foot-pounds determined by a calibrated gauge attached to the hammer and taken when the average penetration in inches per blow is determined (for enclosed ram diesel hammer)

S = average penetration in inches per blow for the last 20 blows.

- F. **Wave Equation Method of Bearing Evaluation.** When plans specify that the bearing capacity of the piling be determined by the wave equation method, submit the following data:

- manufacturer's specification data for the hammer proposed for use, including all modifications and
- complete description and dimensions of all cushioning material used between the pile and helmet and in the cap block, including total thickness of each, and the direction of grain if wood is used.

These data are used by the Engineer to determine the required number of blows per unit of penetration the hammer must deliver to obtain the required bearing resistance.

After evaluation by the wave equation method, any change in the driving equipment may require reevaluation. Such changes must be approved before further driving.

- G. **Test Piling.** Drive test piling at locations shown on the plans or as directed. In general, make test piling part of the completed work, cut off or built up to grade as necessary. Use the required bearing evaluation method to determine bearing resistance.

Initially drive test piling to 3 ft. above plan tip elevation of the regular piling for the structure with the blow count recorded for each foot of driving (for example, drive test piling to 13 ft. above its plan tip elevation if the test piling is 10 ft. longer than regular piling). Retain the cushion if used.

At least 7 days after the original driving, re-drive the test piling the additional length required by the plans with the same hammer and cushion originally used. Record the blow count for each inch of driving for the first foot, for every 3 in. for the next 2 ft., and for each foot thereafter.

Provide the data to the Engineer for use in determining regular piling lengths and K factors. The K factor will be determined based on the following formula:

$$K = P_R/P$$

where:

K = a static correction factor applied to the evaluation method

P_R = re-drive bearing (tons) of the test pile determined by the evaluation method

P = original bearing (tons) of test pile determined by the evaluation method.

H. Test-Loaded Piling. Conduct test load in accordance with Item 405, "Foundation Test Load."

Provide the data to the Engineer for use in determining regular piling lengths and K factors. The K factor will be determined based on the following formula:

$$K = L/P$$

where:

K = a static correction factor applied to the evaluation method

L = maximum safe static load proven by test load

P = bearing resistance of the test loaded pile determined by the evaluation method.

404.4. Measurement and Payment. The work performed, materials furnished, equipment, labor, tools, and incidentals will not be paid for directly, but will be considered subsidiary to pertinent Items.

405.1 to 405.4

ITEM 405 FOUNDATION TEST LOAD

405.1. Description. Test-load piling or drilled shafts.

405.2. Materials. Provide piling or drilled shafts for test loading as shown on the plans.

405.3. Equipment. Unless otherwise shown on the plans, the Department will furnish the jacking equipment, jacking beams, and displacement indicators. Furnish all necessary tools and equipment not furnished by the Department.

405.4. Construction. Furnish and drive the piling or construct the shaft to be test-loaded, and furnish necessary anchors. Drive anchor and test piling in accordance with Item 404, "Driving Piling." Construct anchor and test shafts in accordance with Item 416, "Drilled Shaft Foundations." To develop a satisfactory procedure for drilling the test shaft, construct anchor shafts first. Use the same procedure for drilling the test shaft as for the shafts required in the structure.

Keep a complete record of pile-driving data and shaft-drilling data for all foundations used in the test load. Apply the test load no earlier than the seventh day after driving the test piling or after placing concrete in the test shaft. Do not load the test shaft until the concrete design strength has been attained.

Construct a shelter to protect the test load equipment from weather and direct sunlight, and furnish incidentals necessary for the handling, transportation, and installation of the complete test load setup.

Apply incremental static loads to the pile or shaft and measure the resulting settlement. Apply loads by a hydraulic jack acting against suitable anchorage, transmitting the load directly to the pile or shaft. Carry all test loads to failure of the test pile or test shaft as directed.

Load and record data in accordance with "Test Loading Piling," Construction Bulletin C-8, *Pile Driving Manual*; or "Test Loading Drilled Shafts," Construction Bulletin C-9, *Drilled Shaft Manual*. Provide the data to the Engineer for evaluation.

After completing the test, dismantle the test setup.

Upon completion of the test load, remove piling or shafts that are not part of the structure, or cut off at least 1 ft. below the bottom of the footing or the

finished grade. If permanent piling is raised during the test load, re-drive it to its original grade and bearing.

405.5. Measurement. Measurement will be made for each complete test load satisfactorily performed and accepted.

405.6. Payment. The work performed and materials furnished in accordance with this Item and measured as provided under "Measurement" will be paid for at the unit price bid for each "Foundation Test Load." This price is full compensation for material, equipment, labor, work, tools, and incidentals.

Anchor and test piling or anchor and test shafts that are not part of the permanent structure will not be paid for directly, but will be subsidiary to this Item. Anchor and test piling or anchor and test shafts that are part of the permanent structure will be paid for under the pertinent Items.

ITEM 406 TIMBER PILING

406.1. Description. Furnish and place treated or untreated timber piling.

406.2. Materials. Furnish timber piling in accordance with the requirements of ASTM D 25. For untreated piling, use any species of durable timber that will satisfactorily stand driving. For treated piling, use Southern pine or Douglas fir impregnated with a preservative in accordance with Item 492, "Timber Preservative and Treatment," or as shown on the plans.

Furnish round piling in the lengths shown on the plans, with a minimum circumference of 38 in. for piling 40 ft. or less in length, and 41 in. for piling over 40 ft. Measure the circumference under the bark at a section 3 ft. from the butt.

Treat cuts, bolt holes, and other areas where the surface of the piling is broken in accordance with Item 492, "Timber Preservative and Treatment."

A. Inspection. All piling is subject to inspection before and after treatment. Allow the inspector free access to all sites where materials are being produced or processed, and provide any assistance necessary for the proper inspection of materials. The engineer or inspection agency that performed the inspection must brand the butt and tip of each acceptable pile with a marking hammer showing identity of the engineer or inspection agency.

406.3 to 406.4

- B. Storing and Handling.** Prevent excessive splitting, checking, warping, distortion, or any other damage that may cause the piling to be rejected. Handle treated timber piling carefully without dropping, breaking outer fibers, bruising, or penetrating the surface with tools.

406.3. Equipment. Handle piling with rope slings. Use handling equipment that does not penetrate the treated shell into untreated wood.

406.4. Construction. Drive piling in accordance with Item 404, “Driving Piling.”

- A. Splices, Build-Ups, and Cutoffs.** Saw tops of all piling to a true plane as shown on the plans and at the established elevation. Saw piling that supports timber caps or connects to other members to the exact plane of the connected member.

When required, build up piling by splicing on an additional length of piling of the same diameter and quality. Make splices in accordance with the details shown on the plans or as directed by the Engineer. Construct the splice after the pile head and the lower end of the build-up section have been squared up and treated in accordance with Section 406.4.B, “Treatment of Pile Ends.” Use a long enough build-up section to preclude the need for more than 1 splice. Do not use more than 1 splice in any single pile.

B. Treatment of Pile Ends.

- 1. Treated Timber.** After cutting, give the ends of piling 3 coats of a preservative determined appropriate for the original preservative per AWWA Standard M4. Follow with 1 coat of coal-tar roofing cement meeting the requirements of ASTM D 4022.
- 2. Untreated Timber.** Coat the heads of piling thoroughly with a thick protective coat of hot tar, hot asphaltum, or hot creosote.

When indicated on the plans, cover the pile heads after treatment with a sheet of 20-gauge galvanized metal. Provide a cover that overlaps the sides of the piling at least 3 in. Bend the cover down over the piling and fasten it with large-headed galvanized nails or as shown on the plans.

When cutting or hole boring occurs after treatment or when the surface of treated piling is damaged, treat in accordance with the requirements of Item 492, “Timber Preservative and Treatment.”

406.5. Measurement.

- A. Timber Piling.** Timber piling will be measured by the foot of acceptable piling in place after all cutoffs and splices have been made. When the Contractor elects to drive piling deeper than required to meet the specified length and bearing requirements, no measurement will be made on that portion below the elevation at which length and bearing requirements were first obtained.
- B. Splices.** Splices will be measured by each authorized, completed splice made necessary by driving beyond the plan pile length to obtain required bearing resistance. No measurement will be made for a splice made necessary by unsuitable material, handling, driving, or overdriving.
- C. Cutoffs.** Cutoffs will be measured by the foot of cutoff above required grade. No cutoff will be measured on any pile that is built up.

406.6. Payment. The price bid is full compensation for jetting, pilot holes, alignment holes, driving piling, repairs, materials, equipment, tools, labor, and incidentals.

- A. Timber Piling.** The work performed and materials furnished in accordance with this Item and measured as provided under “Measurement” will be paid for at the unit price of “Treated Timber Piling” or “Untreated Timber Piling.”
- B. Splices.** An additional payment for each completed authorized splice, regardless of buildup length, will be made at a price equal to 4 times the unit price bid for “Treated Timber Piling” or “Untreated Timber Piling.” Where piling is trimmed back for the purpose of constructing a splice, payment for the cutoff is included in the payment for the splice.
- C. Cutoffs.** Payment for cutoff lengths will be made at a price equal to 1/2 the unit price bid for “Treated Timber Piling” or “Untreated Timber Piling.”

ITEM 407
STEEL PILING

407.1. Description. Furnish and place steel H-piling and sheet piling.

407.2. Materials. Furnish steel H-piling and steel sheet piling in accordance with Item 441, “Steel Structures,” and details shown on the plans.

407.2 to 407.2

For H-piling, furnish steel that meets ASTM A 572 Grade 50 or ASTM A 588. For hot-rolled sheet piling, furnish steel that meets ASTM A 328 or ASTM A 572 Grade 50. For cold-rolled sheet piling, furnish steel that meets ASTM A 572 Grade 50. Steel sheet piling may be substituted with a section modulus and minimum thickness of material equal to or greater than that of the section specified. If a hot-rolled section is specified, the substitute section must also be hot-rolled.

Furnish piling in the lengths indicated on the plans. Where test piling is required, the Engineer will approve lengths based on test driving data or test load data. Do not fabricate piling until the Engineer has determined the approved lengths.

At the Contractor's expense, the piling may be fabricated by welding together up to 3 sections of piling with a minimum section length of 5 ft.

Unless otherwise shown on the plans, shop-paint piling with 3.0 mils minimum dry film thickness (DFT) inorganic zinc primer in accordance with the System III or IV paint protection system specified in Item 446, "Cleaning and Painting Steel." Do not apply appearance or intermediate coatings unless specified on the plans. Paint the portion of the pile to be above ground, in water, and a minimum distance of 10 ft. below ground based on the ground line shown in the plans.

Reinforce steel H-pile tips as directed when the piling is to be driven into rock, shale, or other material of similar hardness. Use the pile tip reinforcement detail shown in Figure 1 or attach prefabricated pile points manufactured from ASTM A 27 Grade 65-35 or ASTM A 148 Grade 80-50 material. Furnish certification that materials conform to this requirement.

Store piling above ground on adequate blocking. Keep piling clean and fully drained at all times during storage.

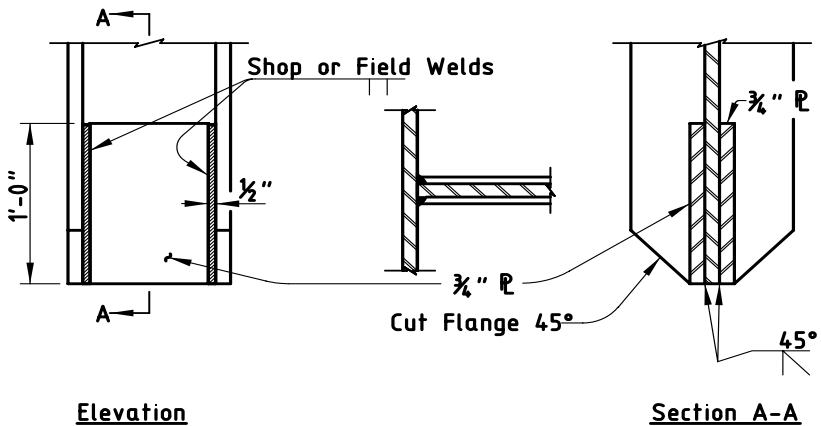

Figure 1
Pile tip reinforcement.

407.3. Construction. Drive piling in accordance with Item 404, “Driving Piling.” Test-load, when required, in accordance with Item 405, “Foundation Test Load.”

- A. Splices and Cutoffs.** Make all splices for steel H-piling in accordance with Figure 2. If the required penetration or bearing resistance has not been obtained, drive spliced piling the additional depth required as soon as the splice is completed.

After driving the piling to the approximate penetration and bearing resistance required, cut it off square at plan grade or to the established grade. If the head of the pile is appreciably distorted or otherwise damaged below cutoff level, cut off the damaged portion and splice an undamaged section in its place, at no additional expense to the Department.

Prepare sheet pile splices similar to the details shown for H-piling. Do not interfere with the interlocks.

Weld in accordance with Item 448, “Structural Field Welding.”

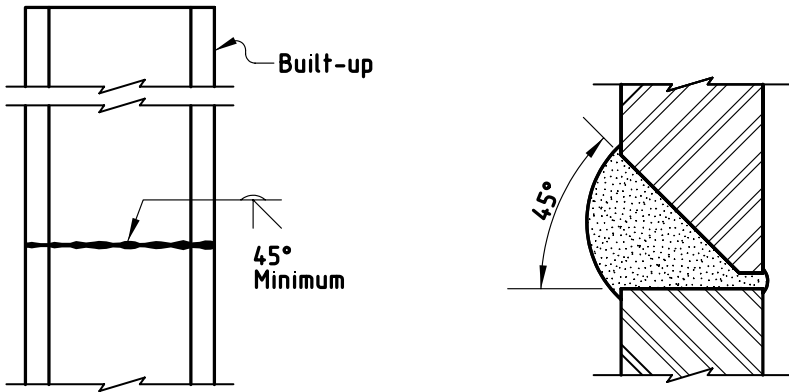

Figure 2
Steel piling splice detail.

- B. Painting.** Apply paint in accordance with Item 446, “Cleaning and Painting Steel.” After driving piling, clean and paint damaged areas, field splices, or areas missing the shop coat with enough epoxy zinc primer to bring the total zinc primer to the minimum 3.0 mils DFT. When a polyurethane appearance coating is specified on the plans, apply at least 2.0 mils DFT each of the System III epoxy intermediate coating and appearance coating. When an acrylic latex appearance coating is specified on the plans, apply at least 2.0 mils DFT of the System IV appearance coating. Use a concrete gray appearance coating unless shown otherwise on the plans. Extend the paint 1 ft. below finished ground line unless the piling is standing in water, in which case extend the paint to the low water line. Replace any earth removed for this painting after the paint has dried.
- C. Test Piling.** Test piling must meet requirements for steel piling. The Engineer may adjust the number of test piling to secure desired information.

407.4. Measurement.

A. Steel H-Piling.

- 1. Steel Piling.** Steel H-piling and Steel H-test piling will be measured by the foot of acceptable piling in place after all cutoffs and splices have been made. When the Contractor elects to drive

piling deeper than required to meet the specified length and bearing requirements, no measurement will be made on that portion below the elevation at which length and bearing requirements were first obtained.

2. **Splices.** Splices will be measured by each authorized splice made necessary by driving beyond the plan pile length to obtain the required bearing resistance.
 3. **Reinforced Tips.** Reinforced tips will be measured by each pile tip, when required.
- B. Steel Sheet Piling.** Steel sheet piling will be measured by the square foot of acceptable piling in place. Sheet piling driven below the elevation required by the plans or the elevation authorized by the Engineer will not be measured for payment.

407.5. Payment. No direct payment will be made for painting or excavation and backfill required for the painting of portions of piling below ground line. Payment for all work and materials required by these items will be included in the unit price bid for “Steel H-Piling,” “Steel H-Test Piling,” or “Sheet Piling.”

The price bid is full compensation for jetting, pilot holes, alignment holes, driving piling, painting, materials, tools, equipment, labor, and incidentals, except that any test load ordered by the Engineer that is not provided for in the Contract will be paid for in accordance with Article 9.4, “Payment for Extra Work.”

A. Steel H-Piling.

1. **Steel Piling.** The work performed and materials furnished in accordance with this Item and measured as provided under “Measurement” will be paid for at the unit price bid for the specified size and weight of “Steel H-Piling” or “Steel H-Test Piling.”
2. **Splices.** An additional payment for each completed authorized splice for both regular and test piling, regardless of buildup length, will be made at a price equal to 4 times the unit price bid for “Steel H-Piling.”
3. **Cutoffs.** Cutoffs will not be paid for directly, but will be subsidiary to this Item.
4. **Reinforced Tips.** An additional payment for each completed authorized pile tip for both regular and test piling will be made at a price equal to 2 times the unit price bid for “Steel H-Piling.”

409.1 to 409.3

- B. Steel Sheet Piling.** Steel sheet piling will be paid for at the unit price bid per square foot for “Sheet Piling” of the type shown on the plans. No payment will be made for cutoffs or splices of sheet piling.

ITEM 409

PRESTRESSED CONCRETE PILING

409.1. Description. Furnish and place prestressed concrete piling.

409.2. Materials. Use materials that meet the requirements of the following Items:

- Item 420, “Concrete Structures”
- Item 421, “Hydraulic Cement Concrete”
- Item 426, “Prestressing”
- Item 440, “Reinforcing Steel.”

Fabricate prestressed concrete piling in accordance with the following Items:

- Item 424, “Precast Concrete Structures (Fabrication)”
- Item 425, “Precast Prestressed Concrete Structural Members.”

Furnish piling in the lengths indicated on the plans when test or test-loaded piling is not required. When test or test-loaded piling is required, the Engineer will approve lengths based on test driving data or test load data. Do not cast regular piling until the Engineer has determined the approved lengths based on the test or test-loaded piling.

409.3. Construction. Handle and store piling in a way that minimizes the risk of damage by impact or bending stress. Store piling above ground on adequate blocking. Do not use chain slings to handle piling. For any damaged piling, immediately review and correct conditions causing the damage. Drive piling in accordance with Item 404, “Driving Piling.” Test-load, when required, in accordance with Item 405, “Foundation Test Load.”

A. Defects and Breakage. Damage to piling due to faulty materials or construction methods may be cause for rejection. Piling cracked in the process of fabrication, handling, storing, hauling, or driving is subject to the following provisions:

- Piling with 1 or more cracks transverse to the longitudinal reinforcement or strand, 1/16 in. or wider, will be rejected if the crack occurs in a portion that will be below ground or water level after driving. If the crack will be located above ground or water level when driving is complete, the piling may be used if it is cut

back to the crack and rebuilt to grade. No additional payment will be made for this buildup.

- Piling with 1 or more cracks transverse to the longitudinal reinforcement or strand that is less than 1/16 in. wide may be used if the crack is repaired in accordance with Item 780, "Epoxy Injection." If cracks develop during driving in the portion that will be below ground, stop driving and repair the cracks before continuing.
- Piling with one or more cracks parallel or diagonal to the longitudinal reinforcing steel or strand and extending to the determined plane of reinforcement may be rejected. If cracks are found acceptable, repair them in accordance with Item 780, "Epoxy Injection."
- Fine hairline cracks or surface checks that do not extend to the plane of the nearest reinforcing steel, as determined by the Engineer, will not require repair and will not be cause for rejection.

B. Buildups and Cutoffs. Construct buildups in accordance with plan details and Item 420, "Concrete Structures." For cutoffs, make the final cut of the concrete square to the longitudinal axis.

C. Test Piling. Test piling must meet requirements for prestressed concrete piling. The Engineer may adjust the number of test piles to secure desired information.

409.4. Measurement.

A. Concrete Piling. Prestressed concrete piling and prestressed concrete test piling will be measured by the foot of acceptable piling in place after all cutoffs and buildups have been made. When the Contractor elects to drive piling deeper than required to meet the specified length and bearing requirements, no measurement will be made on that portion below the elevation at which length and bearing requirements were first obtained.

B. Buildups. Buildups will be measured by each authorized, completed buildup made necessary by driving beyond the plan pile length to obtain required bearing resistance. No measurement will be made for a buildup made necessary by improper casting, handling, or driving.

C. Cutoffs. Cutoffs for both regular and test piling will be measured by the foot of cutoff above required grade.

409.5. Payment. The price bid is full compensation for jetting, pilot holes, alignment holes, repairs, materials, tools, equipment, labor, and incidentals.

409.5 to 416.2

Test-loaded piling and associated anchor piling will be paid for as provided in Item 405, "Foundation Test Load" except that any test load ordered by the Engineer that is not provided for in the Contract will be paid for in accordance with Article 9.4, "Payment for Extra Work."

- A. Concrete Piling.** The work performed and materials furnished in accordance with this Item and measured as provided under "Measurement" will be paid for at the unit price bid for "Prestressed Concrete Piling" or "Prestressed Concrete Test Piling" of the size specified.
- B. Buildups.** An additional payment for each completed authorized buildup splice for both regular and test piling, regardless of buildup length, will be made at a price equal to 10 times the unit price bid for "Prestressed Concrete Piling." Where piling is broken back for constructing buildups, payment for the breakback is included in the payment for buildups.
- C. Cutoffs.** Payment for cutoff lengths of both regular piling and test piling will be made at a price equal to 1/2 the unit price bid per foot for "Prestressed Concrete Piling."

ITEM 416

DRILLED SHAFT FOUNDATIONS

416.1. Description. Construct foundations consisting of reinforced or non-reinforced concrete drilled shafts with or without bell footings.

416.2. Materials. Use materials that meet the requirements of the following Items:

- Item 421, "Hydraulic Cement Concrete"
- Item 440, "Reinforcing Steel"
- Item 448, "Structural Field Welding."

Unless otherwise shown on the plans, use concrete for drilled shafts that meets the requirements of Table 1.

Table 1
Concrete for Drilled Shafts

Drilled Shaft Type	Concrete
Non-reinforced	Class A
Reinforced	Class C
Slurry and underwater concrete placement	Class SS

Use coarse aggregate Grade 4, 5, or 6 for drilled shaft concrete in reinforced drilled shafts. Grade 2 or 3 may be used if the shaft is dry and reinforcing steel has a 5-in. minimum clear spacing.

Use a water-reducing, retarding admixture in accordance with DMS-4640, "Chemical Admixtures for Concrete," in all concrete when using casing that will be pulled or when placing shafts underwater or under slurry.

Use concrete with slump that meets the requirements of Table 2 as determined by Tex-415-A.

Table 2
Slump Requirements

Placement Type	Minimum Acceptable Placement Slump, in.	Recommended Design and Placement Slump, in.	Maximum Acceptable Placement Slump, in.
Dry	5-1/2	6-1/2	7-1/2
Underwater and under slurry	7	8	9

When casing is to be pulled or when concrete is to be placed underwater or under slurry, perform a slump loss test in accordance with Tex-430-A before beginning work. Provide concrete that will maintain a slump of at least 4 in. throughout the entire anticipated time of concrete placement. Time of concrete placement is described in Sections 416.3.F, "Concrete," and 416.3.G, "Additional Requirements for Slurry Displacement or Underwater Concrete Placement Methods." Note the temperature of the concrete mix at the beginning of the slump loss test. If concrete temperature at the time of placement into the drilled shaft is more than 10° higher than the slump loss test temperature, do not place the concrete. Use ice or other concrete cooling ingredients to lower concrete temperature, or run additional slump loss tests at the higher temperatures. Slump loss testing will be waived if anticipated time of concrete placement is less than 90 minutes.

Use drilling slurry that meets the requirements of Table 3, as determined by Tex-130-E.

**Table 3
Slurry Requirements**

Before Introduction into the Excavation		Sampled from the Bottom of the Excavation before Concreting		
Specific Gravity	Sand Content	Specific Gravity	Viscosity (seconds)	Sand Content
≤ 1.10	≤ 1%	≤ 1.15	≤ 45	≤ 6%

Use mineral slurry consisting of processed bentonite or attapulgite clays mixed with clean fresh water. Do not use PHPA (partially hydrolized polyacrylamide) polymeric slurry or any other fluid composed primarily of a polymer solution.

Before placing concrete, sample slurry from the bottom of the hole, and test it in accordance with Tex-130-E. Use a pump or air lift to remove slurry that does not meet the requirements of Table 3 while adding fresh clean slurry to the top of the hole to maintain the slurry level. Continue this operation until the slurry sampled from the bottom of the hole meets the requirements.

416.3. Construction. Place the shaft to within the following tolerances.

- Vertical plumbness – 1 in. per 10 ft. of depth.
- Center of shaft located under column – 1 in. of horizontal plan position.
- Center of shaft located under footing – 3 in. of horizontal plan position.

Complete the embankment at bridge ends before installing drilled shafts that pass through the fill. Refer to Item 423, “Retaining Walls,” for provisions for drilled shafts passing through the structural volume of retaining walls.

A. Excavation. The plans indicate the expected depths and elevations for encountering satisfactory bearing material. Excavate as required for the shafts and bell footings through all materials encountered to the dimensions and elevations shown on the plans or required by the site conditions. Removal of man-made obstructions not shown on the plans will be paid for in accordance with Article 9.4, “Payment for Extra Work.” If satisfactory founding material is not encountered at plan elevation, adjust the bottom of the shaft or alter the foundation, as determined by the Engineer, to satisfactorily comply with design requirements. Blasting is not allowed for excavations.

If caving conditions are encountered, stop drilling and adopt a construction method that stabilizes the shaft walls.

Do not excavate a shaft within 2 shaft diameters (clear) of an open shaft excavation, or one in which concrete has been placed in the preceding 24 hours.

Dispose of material excavated from shafts and bells and not incorporated into the finished project. Dispose of excavated material in accordance with the plans and with federal, state, and local laws.

Provide suitable access, lighting, and equipment for proper inspection of the completed excavation and for checking the dimensions and alignment of shafts and bell excavation.

- B. Core Holes.** If directed, take cores to determine the character of the supporting materials. Use a method that will result in recovery of an intact sample adequate for judging the character of the founding material. Such cores should be at least 5 ft. deeper than the proposed founding grade or a depth equal to the diameter of the shaft, whichever is greater. Take these cores when the excavation is approximately complete.
- C. Casing.** Use casing when necessary to prevent caving of the material or to exclude ground water. Provide casing with an outside diameter not less than the specified diameter of the shaft. Use casing strong enough to withstand handling stresses and pressures of concrete and of the surrounding earth or water, and that is watertight, smooth, clean, and free of accumulations of hardened concrete.

Drill the portion of the shaft below the casing as close as possible to the specified shaft diameter. The portion of shaft below the casing may be as much as 2 in. smaller than the specified shaft diameter.

Use construction methods that result in a minimal amount of disturbed soil being trapped outside the casing. This does not apply to temporary undersized casings used to protect workers inside shafts or to drilled shafts designed for point bearing only.

Do not leave any casing in place unless authorized or shown on the plans. Do not extract casing until after placing the concrete to an appropriate level. Maintain sufficient concrete in the casing at all times to counteract soil and water pressure. Before and during concrete placement, rotate or move the casing up or down a few inches if necessary to facilitate extraction of the casing.

- D. Requirements for Slurry Displacement Method.** Unless otherwise shown on the plans, the slurry displacement method may be used to construct drilled shafts. Use this method to support the sides of the

416.3 to 416.3

excavation with processed mineral slurry that is then displaced by concrete to form a continuous concrete shaft.

Do not use casing other than surface casing. Do not use surface casing longer than 20 ft. without approval. Do not extract the surface casing until after placing the concrete.

For slurry mixed at the project site, pre-mix it in a reservoir of sufficient capacity to fill the excavation and for recovery of the slurry during concrete placement. Do not mix slurry in the shaft excavation or other hole. Allow adequate time for hydration of the slurry prior to introduction into the excavation.

During and after drilling maintain a head of slurry in the shaft excavation at or near ground level or higher as necessary to counteract ground water pressure.

Just before placing reinforcing steel, use an air lift or proper size cleanout bucket to remove any material that may have fallen from the sides of the excavation or accumulated on the bottom after the completion of drilling. Use a cleanout bucket if material is too large to be picked up with an air lift.

If concrete placement is not started within 4 hours of the completion of the shaft excavation, reprocess the hole with the auger as directed. Then clean the bottom with an air lift or cleanout bucket, and check the slurry at the bottom of the hole for compliance with the slurry requirements of Article 416.2, "Materials."

If the slurry forms a gel before concrete placement, agitate the congealed slurry to liquefaction just before concrete placement and whenever directed.

Recover and dispose of all slurry as approved by the Engineer, and in accordance with all federal, state, and local laws. Do not discharge slurry into or in close proximity to streams or other bodies of water.

- E. Reinforcing Steel.** Completely assemble the cage of reinforcing steel, and place it as a unit immediately before concrete placement. The cage consists of longitudinal bars and lateral reinforcement (spiral reinforcement, lateral ties, or horizontal bands). If overhead obstacles prevent placement of the cage as a single unit, connect individual segments with couplers or by lapping steel as approved.

If the shaft is lengthened beyond plan length, extend the reinforcing steel cage as follows, unless directed otherwise:

- For shafts supporting structures other than bridges, extend the cage to the bottom.

- For bridge shafts with plan lengths of less than 25 ft., extend the cage to 25 ft. or to the bottom, whichever is shorter.
- For bridge shafts with plan lengths at least 25 ft. that are lengthened less than 33% of plan length, extending the cage is not necessary.
- For bridge shafts with plan lengths at least 25 ft. that are lengthened more than 33% of plan length, extend the cage as directed.

If the cage does not reach the bottom of the shaft, it may be suspended, or a portion of the longitudinal steel may be extended to support the cage on the bottom of the shaft. Bars used to extend or support the cage may be lap spliced or welded by a qualified welder. Place the extension at the bottom of the shaft.

If using spiral reinforcement, tie it to the longitudinal bars at a spacing of at most 24 in., or as required for a stable cage. Do not weld lateral reinforcement to longitudinal bars unless otherwise shown on the plans.

Center the reinforcing steel cage in the excavation using approved centering devices. Use enough devices to hold the cage in position along its entire length. Do not use square concrete spacer blocks in cased shafts.

Support or hold down the cage to control vertical displacement during concrete placement or extraction of the casing. Use support that is concentric with the cage to prevent racking and distortion of the steel.

Check the elevation of the top of the steel cage before and after concrete placement or after casing extraction when casing is used. Downward movement of the steel up to 6 in. per 20 ft. of shaft length and upward movement of the steel up to 6 in. total are acceptable.

Maintain the minimum length of steel required for lap with column steel. Use dowel bars if the proper lap length is provided both into the shaft and into the column. Locate and tie all dowel bars into the cage before placing concrete or insert dowel bars into fresh, workable concrete.

Locate and tie anchor bolts when required prior to placement of concrete. Use templates or other devices to assure accurate placement of anchor bolts.

- F. Concrete.** Perform all work in accordance with requirements of Item 420, "Concrete Structures." Mass concrete placement requirements do not apply to drilled shafts.

Form portions of drilled shaft that project above natural ground.

416.3 to 416.3

Remove loose material and accumulated seep water from the bottom of the excavation before placing concrete. If water cannot be removed, place concrete using underwater placement methods.

Place concrete as soon as possible after all excavation is complete and reinforcing steel is placed. Provide workable concrete that does not require vibrating or rodding. Vibrate formed portions of drilled shafts.

Place concrete continuously for the entire length of the shaft. For dry shafts of 24 in. or smaller diameter, limit free fall of concrete to 25 ft. Use a suitable tube or tremie to prevent segregation of materials. Use a tube or tremie in sections to provide proper discharge and to permit raising as the placement progresses. For dry shafts over 24 in. diameter, concrete can be allowed to free fall an unlimited distance if it does not strike the reinforcing cage or sides of the hole during placement. When free fall is used, provide a hopper with a minimum 3-ft.-long drop tube at the top of the shaft to direct concrete vertically down the center of the shaft. Do not use a shovel or other means to simply deflect the concrete discharge from the truck.

For cased shafts, maintain a sufficient head of concrete at all times above the bottom of the casing to overcome hydrostatic pressure.

Extract casing at a slow, uniform rate with the pull in line with the axis of the shaft. Monitor the concrete level in the casing during extraction. Stop the extraction and add concrete to the casing as required to ensure a completely full hole upon casing removal. The elapsed time from the mixing of the first concrete placed into the cased portion of the shaft until the completion of extraction of the casing must not exceed the time for which the concrete maintains a slump of over 4 in. in accordance with Article 416.2, "Materials." If the elapsed time is exceeded, modify the concrete mix, the construction procedures, or both for subsequent shafts.

Cure the top surface and treat any construction joint area in accordance with Item 420, "Concrete Structures."

- G. Additional Requirements for Slurry Displacement or Underwater Concrete Placement Methods.** Place concrete on the same day that the shaft is excavated and as soon as possible after all excavation is complete and reinforcing steel is placed. Use an air lift or cleanout bucket of the proper size to clean the bottom of the excavation prior to placing the reinforcing steel cage and concrete. Place concrete through a closed tremie or pump it to the bottom of the excavation. Initially seal the tremie or pump line to positively separate the concrete from the slurry or water. Place concrete continuously from the beginning of

placement until the shaft is completed. If using a tremie, keep it full of concrete and well submerged in the previously placed concrete at all times. Raise the tremie as necessary to maintain the free flow of concrete and the stability of any casing used. If using a pump, keep the discharge tube submerged in the previously placed concrete at all times. Place additional concrete to ensure the removal of any contaminated concrete at the top of the shaft. At the completion of the pour, allow the top portion of concrete to flush completely from the hole until there is no evidence of slurry or water contamination. Do not attempt to remove this concrete with shovels, pumps or other means. Level the top of shaft with hand tools as necessary.

Use a sump or other approved method to channel displaced fluid and concrete away from the shaft excavation. Recover slurry and dispose of it as approved. Do not discharge displaced fluids into or in close proximity to streams or other bodies of water. For pours over water, provide a collar or other means of capturing slurry and the top portion of concrete flushed from the shaft.

If concrete placement is interrupted due to withdrawal of the submerged end of the tremie or pump discharge tube before completion, remove the tube, reseal it at the bottom, penetrate with the tube into the concrete already placed by at least 5 ft., and recharge it before continuing.

The elapsed time from the mixing of the first concrete placed until the completion of concrete placement, including extraction of the casing, must not exceed the time for which the concrete maintains a slump of over 4 in. in accordance with Article 416.2, "Materials." If the elapsed time is exceeded, modify the concrete mix, the construction procedures, or both for subsequent shafts.

- H. Test Load.** If required, test load shafts in accordance with Item 405, "Foundation Test Load."

416.4. Measurement.

- A. Drilled Shaft.** Drilled shaft foundations will be measured by the foot to the bottom of the shaft.
- 1. Interior Bents and Piers.** Shafts will be measured from a point approximately 6 in. below the finished earthwork elevation at the center of each shaft, unless specific elevations or dimensions are indicated on the plans or unless the Engineer directs otherwise to meet unusual conditions. The bent height shown on the plans is for

416.5 to 416.5

estimating purposes only and does not control the top-of-shaft measurement.

2. **Abutment Bents and Retaining Walls.** Shafts will be measured from the bottom of footing or cap elevation.
 3. **Other Non-Bridge Structures.** Shafts will be measured from the top of the shaft.
- B. Bell Footing.** Bell footings will be measured by the cubic yard of concrete outside of the plan dimensions of the shaft. Bell footings are a plans quantity measurement item. The quantity to be paid is the quantity shown in the proposal, unless modified by Article 9.2, "Plans Quantity Measurement." Additional measurements or calculations will be made if adjustments of quantities are required.
- C. Core Hole.** Core holes will be measured by each core hole drilled.

416.5. Payment. The unit prices bid for the various classifications of drilled shafts and bell footings will be full compensation for excavation; furnishing, placing, and removing casing; furnishing, processing, and recovering slurry; pumping; furnishing, and placing reinforcing steel; furnishing and placing concrete, including additional concrete required to fill an oversize casing or oversize excavation; conducting slump loss tests; backfilling; disposing of cuttings and slurry; and materials, tools, equipment, labor, and incidentals.

When the bottom of a drilled shaft is placed at an elevation below plan grade, no direct payment will be made for extra reinforcement placed to support the cage. The extra reinforcement will be considered subsidiary to the price bid per foot of shaft. No extra payment will be made for casings left in place.

No payment will be made for "Bell Footing" or "Drilled Shaft" until the concrete has been placed.

A. Drilled Shaft. The work performed and materials furnished in accordance with this Item and measured as provided under "Measurement" will be paid for at the unit price bid for "Drilled Shaft" or "Drilled Shaft (Non-reinforced)" or "Drilled Shaft (Sign Mounts)" or "Drilled Shaft (High Mast Pole)" of the specified diameter, subject to the limitations for overruns authorized by the Engineer given in Section 416.5.A.1, "Overrun."

1. **Overrun.** Payment for individual completed shaft lengths up to and including 5 ft. in excess of the maximum plan length shaft, as

defined in Section 416.5.A.2, “Maximum Plan Length Shaft,” will be made at the unit price bid per foot of the specified diameter.

Payment for the portion of individual completed shaft length in excess of 5 ft. and up to and including 15 ft. more than the maximum plan length shaft, as defined in this Item, will be made at a unit price equal to 115% of the unit price bid per foot of the specified diameter.

Payment for that portion of individual completed shaft length in excess of 15 ft. more than the maximum plan length shaft, as defined in Section 416.5.A.2, will be made at a unit price equal to 125% of the unit price bid per foot of the specified diameter.

2. **Maximum Plan Length Shaft.** Payment described above is subject to the following provisions for extra depth drilling:
 - For bridge structures, the maximum plan length shaft is the maximum length shaft, regardless of diameter, for any drilled shaft on that specific bridge.
 - For retaining walls, the maximum plan length shaft is the maximum length shaft, regardless of diameter, for any drilled shaft on that specific retaining wall.
 - For overhead sign structures, the maximum plan length shaft is the maximum length shaft, regardless of diameter, for any overhead sign structures included in the contract.
 - For high mast illumination poles, the maximum plan length shaft is the maximum length shaft, regardless of diameter, for any high mast illumination pole included in the contract.
- B. Bell Footing.** Bell footings constructed to specified dimensions will be paid for at the unit price bid per cubic yard for “Bell Footings.” The quantity to be paid for will be the quantity shown on the plans, unless revised by the Engineer in accordance with “Measurement.”
- C. Core Hole.** Core holes will be paid at \$125 each.

ITEM 420
CONCRETE STRUCTURES

420.1. Description. Construct concrete structures.

420.2. Materials.

- A. Concrete.** Provide concrete conforming to Item 421, “Hydraulic Cement Concrete.” For each type of structure or unit, provide the class of concrete shown on the plans or in pertinent governing specifications.
- B. Grout or Mortar.** Provide grout or mortar conforming to Section 421.2.F, “Mortar and Grout.”
- C. Latex.** Provide an acrylic-polymer latex admixture (acrylic resin emulsion per DMS-4640, “Chemical Admixtures for Concrete”) suitable for producing polymer-modified concrete or mortar. Do not allow latex to freeze.
- D. Reinforcing Steel.** Provide reinforcing steel conforming to Item 440, “Reinforcing Steel.”
- E. Expansion Joint Material.** Provide materials that conform to the requirements of DMS-6310, “Joint Sealants and Fillers”:
 - Provide preformed fiber expansion joint material that conforms to the dimensions shown on the plans. Provide preformed bituminous fiber material unless otherwise specified.
 - Provide a Class 4, 5, or 7 low-modulus silicone sealant unless otherwise directed.
 - Provide asphalt board that conforms to dimensions shown on the plans.
 - Provide re-bonded neoprene filler that conforms to the dimensions shown on the plans.
- F. Waterstop.** Provide rubber or polyvinyl chloride (PVC) waterstops that conform to DMS-6160, “Waterstops, Nylon Reinforced Neoprene Sheet, and Elastomeric Pads,” unless otherwise shown on the plans.
- G. Evaporation Retardants.** Provide evaporation retardants that conform to the requirements of DMS-4650, “Hydraulic Cement Concrete Curing Materials and Evaporation Retardants.”
- H. Curing Materials.** Provide membrane curing compounds that conform to the requirements of DMS-4650, “Hydraulic Cement Concrete Curing Materials and Evaporation Retardants.”

Provide cotton mats that consist of a filling material of cotton “bat” or “bats” (at least 12 oz. per square yard) completely covered with unsized cloth (at least 6 oz. per square yard) stitched longitudinally with continuous parallel rows of stitching spaced at less than 4 in., or tuft both longitudinally and transversely at intervals less than 3 in. Provide cotton mats that are free from tears and in good general condition. Provide a flap at least 6 in. wide consisting of 2 thicknesses of the covering and extending along 1 side of the mat.

Provide polyethylene sheeting that is at least 4 mils thick and free from visible defects. Provide only clear or opaque white sheeting when the ambient temperature during curing exceeds 60°F or when applicable to control temperature during mass pours.

Provide burlap-polyethylene mats made from burlap impregnated on 1 side with a film of opaque white pigmented polyethylene, free from visible defects. Provide laminated mats that have at least 1 layer of an impervious material such as polyethylene, vinyl plastic, or other acceptable material (either as a solid sheet or impregnated into another fabric) and are free of visible defects.

- I. **Epoxy.** Unless otherwise specified, provide epoxy materials that conform to DMS-6100, “Epoxy and Adhesives.”

420.3. Equipment.

- A. **Fogging Equipment.** Use fogging equipment that can apply water in a fine mist, not a spray. Produce the fog using equipment that pumps water or water and air under high pressure through a suitable atomizing nozzle. Use hand-held mechanical equipment portable enough to use in the direction of any prevailing wind and adaptable for intermittent use to prevent excessive wetting of the concrete.
- B. **Transporting and Placing Equipment.** Use appropriate transporting and placing equipment such as buckets, chutes, buggies, belt conveyors, pumps, or other equipment as necessary. Do not transport or convey concrete through equipment made of aluminum. Use carts with pneumatic tires for carting or wheeling concrete over newly placed slabs.

Use tremies to control the fall of concrete or for underwater placement. Use tremies that are watertight and of large enough diameter to allow the placement of the concrete but less than 14 in. in diameter. For underwater placements, construct the tremie so that the bottom can be sealed and opened once the tremie has been fully charged with concrete.

420.3 to 420.3

Use pumps with lines at least 5 in. I.D. where Grade 2 or smaller coarse aggregate is used, and at least 8 in. I.D. for Grade 1 coarse aggregate.

- C. Vibrators.** Use immersion-type vibrators for consolidation of concrete. Provide at least 1 standby vibrator for emergency use.
- D. Screeds and Work Bridges for Bridge Slabs.** For bridge slabs use a self-propelled transverse screed or a mechanical longitudinal screed. Use transverse screeds that are able to follow the skew of the bridge for skews greater than 15° unless otherwise approved. Equip transverse screeds with a pan float. Manually operated screeding equipment may be used if approved for top slabs of culverts, small placements, or unusual conditions. Use screeds that are rigid and heavy enough to hold true to shape and have sufficient adjustments to provide for the required camber or section. Equip the screeds, except those of the roller drum type, with metal cutting edges.

For bridge slabs, use sufficient work bridges for finishing operations. Mount a carpet drag to a work bridge or a moveable support system that can vary the area of carpet in contact with the concrete. Use carpet pieces long enough to cover the entire width of the placement. Splice or overlap the carpet as necessary. Ensure that enough carpet is in contact longitudinally with the concrete being placed to provide the desired surface finish. Use artificial grass-type carpeting having a molded polyethylene pile face with a blade length between 5/8 and 1 in. and with a minimum weight of 70 oz. per square yard. Ensure that the carpet has a strong, durable backing not subject to rot and that the facing is adequately bonded to the backing to withstand the intended use. A burlap drag, attached to the pan float on a transverse screed, may be used instead of the carpet drag.

- E. Temperature Recording Equipment.** For mass concrete operations or as otherwise specified, use strip chart temperature recording devices, recording maturity meters in accordance with Tex-426-A, or other approved devices that are accurate to within $\pm 2^\circ\text{F}$ within the range of 32 to 212°F.
- F. Artificial Heating Equipment.** Use artificial heating equipment as necessary for maintaining the concrete temperatures as specified in Section 420.4.G.11, "Placing Concrete in Cold Weather."
- G. Sawing Equipment.** Use sawing equipment capable of cutting grooves in completed bridge slabs and top slabs of direct-traffic culverts. Provide grooves that are 1/8 to 3/16 in. deep and nominally 1/8 in. wide. Groove spacing may range from 5/8 to 1 in. Use sawing

equipment capable of cutting grooves in hardened concrete to within 18 in. of the barrier rail or curb.

- H. Spraying Equipment.** Use mechanically powered pressure sprayers, either air or airless, with appropriate atomizing nozzles for the application of membrane curing. Mechanically driven spraying equipment, adaptable to the rail system used by the screeds, may be used for applying membrane curing to bridge slabs. If approved, use hand-pressurized spray equipment equipped with 2 or 3 fan-spray nozzles. Ensure that the spray from each nozzle overlaps the spray from adjacent nozzles by approximately 50%.
- I. Concrete Testing Equipment.** Provide testing equipment for use by the Engineer in accordance with Section 421.3.C, "Testing Equipment."

420.4. Construction. Before starting work, obtain approval for proposed construction methods. Approval of construction methods and equipment does not relieve the Contractor's responsibility for safety or correctness of methods, adequacy of equipment, or completion of work in full accordance with the Contract.

Unless otherwise shown on the plans, it is the Contractor's option to perform testing on structural concrete (structural classes of concrete are identified in Table 5 of Section 421.4.A, "Classification and Mix Design") to determine the in-situ strength to address the schedule restrictions in Section 420.4.A, "Schedule Restrictions." The Engineer may require the Contractor to perform this testing for concrete placed in cold weather. For Contractor-performed testing, make enough test specimens to ensure that strength requirements are met for the operations listed in Section 420.4.A. Make at least 1 set of test specimens for each element cast each day. Cure these specimens under the same conditions as the portion of the structure involved for all stages of construction. Ensure safe handling, curing, and storage of all test specimens. Provide testing personnel, and sample and test the hardened concrete in accordance with Section 421.4.G, "Sampling and Testing of Concrete." The maturity method, Tex-426-A, may be used for in-situ strength determination for schedule restrictions if approved. Coring will not be allowed for in-situ strength determination for schedule restrictions. Provide the Engineer the opportunity to witness all testing operations. Report all test results to the Engineer.

If the Contractor does not wish to perform schedule restriction testing, the Engineer's 7-day lab-cured tests, performed in accordance with Section 421.4.G.5, "Adequacy and Acceptance of Concrete," will be used

420.4 to 420.4

for schedule restriction determinations. The Engineer may require additional time for strength gain to account for field curing conditions such as cold weather.

A. Schedule Restrictions. Unless otherwise shown on the plans, construct and open completed structures to traffic with the following limitations:

- 1. Setting Forms.** Attain at least 2,500 psi compressive strength before erecting forms on concrete footings supported by piling or drilled shafts, or on individual drilled shafts. Erect forms on spread footings and culvert footings after the footing concrete has aged at least 2 curing days as defined in Section 420.4.J, "Curing Concrete." Place concrete only after the forms and reinforcing steel have been inspected by the Engineer.

Support tie beam or cap forms by falsework on previously placed tie beams only if the tie beam concrete has attained a compressive strength of 2,500 psi and the member is properly supported to eliminate stresses not provided for in the design. Maintain curing as required until completion of the curing period.

Place superstructure forms or falsework on the substructure only if the substructure concrete has attained a compressive strength of 3,000 psi.

- 2. Removal of Forms and Falsework.** Keep in place weight-supporting forms and falsework for bridge components and culvert slabs until the concrete has attained a compressive strength of 2,500 psi in accordance with Section 420.4.K, "Removal of Forms and Falsework." Keep all forms for mass placements defined in Section 420.4.G.14, "Mass Placements," in place for 4 days following concrete placement.
- 3. Placement of Superstructure Members.** Do not place superstructure members before the substructure concrete has attained a compressive strength of 3,000 psi.
- 4. Longitudinal Screeding of Bridge Slabs.** Place a longitudinal screed directly on previously placed concrete slabs to check and grade an adjacent slab only after the previously placed slab has aged at least 24 hr. Place and screed the concrete after the previously placed slabs have aged at least 48 hr. Maintain curing of the previously placed slabs during placement.
- 5. Staged Placement of Bridge Slabs on Continuous Steel Units.** When staged placement of a slab is required, ensure that the previously placed concrete attains a compressive strength of

3,000 psi before placing the next stage placement. Multiple stages may be placed in a single day if approved.

6. **Storage of Materials on the Structure.** Obtain approval to store materials on completed portions of a structure once a compressive strength of 3,000 psi has been attained. Maintain proper curing if materials will be stored on structures before completion of curing.
7. **Placement of Equipment and Machinery.** Do not place erection equipment or machinery on the structure until the concrete has attained the design strength specified in Section 421.4.A, "Classification and Mix Design," unless otherwise approved.
8. **Carting of Concrete.** Once the concrete has attained a compressive strength of 3,000 psi, it may be carted, wheeled, or pumped over completed slabs. Maintain curing during these operations.
9. **Placing Bridge Rails.** Reinforcing steel and concrete for bridge rails may be placed on bridge slabs once the slab concrete has attained a compressive strength of 3,000 psi. If slipforming methods are used for railing concrete, ensure the slab concrete has attained its design strength specified in Section 421.4.A, "Classification and Mix Design," before placing railing concrete.
10. **Opening to Construction Traffic.** Bridges and direct-traffic culverts may be opened to all construction traffic when the design strength specified in Section 421.4.A, "Classification and Mix Design," has been attained if curing is maintained.
11. **Opening to Full Traffic.** Bridges and direct-traffic culverts may be opened to the traveling public when the design strength specified in Section 421.4.A, "Classification and Mix Design," has been attained for all structural elements including railing subject to impact from traffic, when curing has been completed for all slabs, and when the concrete surface treatment has been applied in accordance with Item 428, "Concrete Surface Treatment." Obtain approval before opening bridges and direct-traffic culverts to the traveling public. Other noncritical structural and nonstructural concrete may be opened for service upon the completion of curing unless otherwise specified or directed.
12. **Post-Tensioned Construction.** For structural elements designed to be post-tensioned ensure that strength requirements on the plans are met for stressing and staged loading of structural elements.

420.4 to 420.4

13. Backfilling. Backfill in accordance with Section 400.3.C, “Backfill.”

B. Plans for Falsework and Forms. Submit 2 copies of plans for falsework and forms for piers, superstructure spans over 20 ft. long, bracing systems for girders when the overhang exceeds 3 ft. 6 in., and bridge widening details. Submit similar plans for other units of the structure as directed. Show all essential details of proposed forms, falsework, and bracing. Have a licensed professional engineer design, seal, and sign these plans. Department approval is not required, but the Department reserves the right to request modifications to the plans. The Contractor is responsible for the adequacy of these plans.

C. Falsework. Design and construct falsework to carry the maximum anticipated loads safely, including wind loads, and to provide the necessary rigidity. Submit details in accordance with Section 420.4.B, “Plans for Falsework and Forms.”

Design job-fabricated falsework assuming a weight of 150 pcf for concrete, and include a liveload allowance of 50 psf of horizontal surface of the form. Do not exceed 125% of the allowable stresses used by the Department for the design of structures.

For commercially produced structural units used in falsework, do not exceed the manufacturer’s maximum allowable working loads for moment and shear or end reaction. Include a liveload allowance of 35 psf of horizontal form surface in determining the maximum allowable working load for commercially produced structural units.

Provide timber that is sound, in good condition, and free from defects that would impair its strength. Provide timber that meets or exceeds the species, size, and grade requirements in the submitted falsework plans.

Provide wedges made of hardwood or metal in pairs to adjust falsework to desired elevations to ensure even bearing. Do not use wedges to compensate for incorrectly cut bearing surfaces.

Use sills or grillages that are large enough to support the superimposed load without settlement. Take precautions to prevent settling of the supporting material unless the sills or grillages are founded on solid rock, shale, or other hard materials.

Place falsework that cannot be founded on a satisfactory spread footing on piling or drilled shafts with enough bearing capacity to support the superimposed load without settlement. Drive falsework piling to the required resistance determined by the applicable formula in Item 404,

“Driving Piling.” Design drilled shafts for falsework to carry the superimposed load using both skin friction and point bearing.

Weld in conformance with Item 448, “Structural Field Welding.” Securely brace each falsework bent to provide the stiffness required, and securely fasten the bracing to each pile or column it crosses.

Remove falsework when it is no longer required or as indicated on the submitted falsework plan. Pull or cut off foundations for falsework at least 2 ft. below finished ground level. Completely remove falsework, piling, or drilled shafts in a stream, lake, or bay to the approved limits to prevent obstruction to the waterway.

D. Forms. Submit formwork plans in accordance with Section 420.4.B, “Plans for Falsework and Forms.”

1. General. Except where otherwise specified or permitted, provide forms of either timber or metal.

Design forms for the pressure exerted by a liquid weighing 150 pcf. Take the rate of concrete placement into consideration in determining the depth of the equivalent liquid. Include a liveload allowance of 50 psf of horizontal surface for job-fabricated forms. Do not exceed 125% of the allowable stresses used by the Department for the design of structures.

For commercially produced structural units used for forms, do not exceed the manufacturer’s maximum allowable working loads for moment and shear or end reaction. Include a liveload allowance of 35 psf of horizontal form surface in determining the maximum allowable working load for commercially produced structural units.

Provide steel forms for round columns unless otherwise approved. Refer to Item 427, “Surface Finishes for Concrete,” for additional requirements for off-the-form finishes.

Provide commercial form liners for imprinting a pattern or texture on the concrete surface as shown on the plans and specified in Section 427.4.B.2.d, “Form Liner Finish.”

Provide forming systems that are practically mortar-tight, rigidly braced, and strong enough to prevent bulging between supports, and maintain them to the proper line and grade during concrete placement. Maintain forms in a manner that prevents warping and shrinkage. Do not allow offsets at form joints to exceed 1/16 in.

420.4 to 420.4

For forms to be left in place, use only material that is inert, nonbiodegradable, and nonabsorptive.

Attachment of forms or screed supports for bridge slabs to steel I-beams or girders may be by welding subject to the following requirements:

- Do not weld to tension flanges or to areas indicated on the plans.
- Weld in accordance with Item 448, “Structural Field Welding.”

Take into account:

- deflections due to cast-in-place slab concrete and railing shown in the dead load deflection diagram in the setting of slab forms,
- differential beam or girder deflections due to skew angles and the use of certain stay-in-place slab forming systems, and
- deflection of the forming system due to the wet concrete.

For bridge approach slabs, securely stake forms to line and grade and maintain in position. Rigidly attach inside forms for curbs to the outside forms.

Construct all forms to permit their removal without marring or damaging the concrete. Clean all forms and footing areas of any extraneous matter before placing concrete. Provide openings in forms if needed for the removal of laitance or foreign matter

Treat the facing of all forms with bond-breaking coating of composition that will not discolor or injuriously affect the concrete surface. Take care to prevent coating of the reinforcing steel.

Complete all preparatory work before requesting permission to place concrete.

If the forms show signs of bulging or sagging at any stage of the placement, cease placement and remove the portion of the concrete causing this condition immediately if necessary. Reset the forms and securely brace them against further movement before continuing the placement.

2. **Timber Forms.** Provide properly seasoned good-quality lumber that is free from imperfections that would affect its strength or impair the finished surface of the concrete. Provide timber or lumber that meets or exceeds the requirements for species and grade in the submitted formwork plans.

Maintain forms or form lumber that will be reused so that it stays clean and in good condition. Do not use any lumber that is split, warped, bulged, or marred or that has defects that will produce inferior work, and promptly remove such lumber from the work.

Provide form lining for all formed surfaces except:

- the inside of culvert barrels, inlets, manholes, and box girders;
- the bottom of bridge slabs between beams or girders;
- surfaces that are subsequently covered by backfill material or are completely enclosed; and
- any surface formed by a single finished board or by plywood.

Provide form lining of an approved type such as masonite or plywood. Do not provide thin membrane sheeting such as polyethylene sheets for form lining.

Use plywood at least 3/4 in. thick. Place the grain of the face plies on plywood forms parallel to the span between the supporting studs or joists unless otherwise indicated on the submitted form drawings.

Use plywood for forming surfaces that remain exposed that meets the requirements for B-B Plyform Class I or Class II Exterior of the U.S. Department of Commerce Voluntary Product Standard PS 1.

Space studs and joists so that the facing form material remains in true alignment under the imposed loads.

Space wales closely enough to hold forms securely to the designated lines, scabbed at least 4 ft. on each side of joints to provide continuity. Place a row of wales near the bottom of each placement.

Place facing material with parallel and square joints, securely fastened to supporting studs.

For surfaces exposed to view and receiving only an ordinary surface finish as defined in Section 420.4.M, "Ordinary Surface Finish," place forms with the form panels symmetrical (long dimensions set in the same direction). Make horizontal joints continuous.

Make molding for chamfer strips or other uses of materials of a grade that will not split when nailed and that can be maintained to a true line without warping. Dress wood molding on all faces. Unless otherwise shown on the plans, fill forms at all sharp corners

420.4 to 420.4

and edges with triangular chamfer strips measuring 3/4 in. on the sides.

To hold forms in place, use metal form ties of an approved type or a satisfactory substitute of a type that permits ease of removal of the metal. Cut back wire ties at least 1/2 in. from the face of the concrete.

Use devices to hold metal ties in place that are able to develop the strength of the tie and adjust to allow for proper alignment.

Entirely remove metal and wooden spreaders that separate the forms as the concrete is being placed.

Provide adequate clean-out openings for narrow walls and other locations where access to the bottom of the forms is not readily attainable.

- 3. Metal Forms.** Requirements for timber forms regarding design, mortar-tightness, filleted corners, beveled projections, bracing, alignment, removal, reuse, and wetting also apply to metal forms except that metal forms do not require lining unless specifically noted on the plans.

Use form metal thick enough to maintain the true shape without warping or bulging. Countersink all bolt and rivet heads on the facing sides. Design clamps, pins, or other connecting devices to hold the forms rigidly together and to allow removal without damage to the concrete. Use metal forms that present a smooth surface and that line up properly. Keep metal free from rust, grease, and other foreign materials.

- 4. Form Supports for Overhang Slabs.** Form supports that transmit a horizontal force to a steel girder or beam or to a prestressed concrete beam are permitted provided a satisfactory structural analysis has been made of the effect on the girder or beam as indicated in the submitted formwork plans.

When overhang brackets are used on prestressed concrete beam spans with slab overhangs not exceeding 3 ft 6 in., use beam bracing as indicated in the plans. For spans with overhangs exceeding this amount, use additional support for the outside beams regardless of the type of beam used. Submit details of the proposed bracing system in accordance with Section 420.4.B, "Plans for Falsework and Forms."

Punch or drill holes full size in the webs of steel members for support of overhang brackets, or torch-cut them to 1/4 in. under

size and ream them full size. Do not burn the holes full size. Leave the holes open unless otherwise shown on the plans. Never fill the holes by welding.

- E. Drains.** Install and construct weep holes and roadway drains as shown on the plans.
- F. Placing Reinforcement.** Place reinforcement as provided in Item 440, "Reinforcing Steel." Do not weld reinforcing steel supports to I-beams or girders or to reinforcing steel except where shown on the plans.

Place post-tensioning ducts in accordance with the approved prestressing details and in accordance with Item 426, "Prestressing." Keep ducts free of obstructions until all post-tensioning operations are complete.

- G. Placing Concrete.** Give the Engineer sufficient advance notice before placing concrete in any unit of the structure to permit the inspection of forms, reinforcing steel placement, and other preparations.

Follow the sequence of placing concrete shown on the plans or specified.

Do not place concrete when impending weather conditions would impair the quality of the finished work. If conditions of wind, humidity, and temperature are such that concrete cannot be placed without the potential for shrinkage cracking, place concrete in early morning or at night or adjust the placement schedule for more favorable weather. Consult the evaporation rate nomograph in the Portland Cement Association's *Design and Control of Concrete Mixtures* for shrinkage cracking potential. When mixing, placing, and finishing concrete in non-daylight hours, adequately illuminate the entire placement site as approved.

If changes in weather conditions require protective measures after work starts, furnish adequate shelter to protect the concrete against damage from rainfall or from freezing temperatures as outlined in this Item. Continue operations during rainfall only if approved. Use protective coverings for the material stockpiles. Cover aggregate stockpiles only to the extent necessary to control the moisture conditions in the aggregates.

Allow at least 1 curing day after the concrete has achieved initial set before placing strain on projecting reinforcement to prevent damage to the concrete.

420.4 to 420.4

1. **Placing Temperature.** Place concrete according to the following temperature limits for the classes of concrete defined in Section 421.4.A, “Classification and Mix Design”:
 - Place Class C, F, H, K, or SS concrete only when its temperature at time of placement is between 50 and 95°F. Increase the minimum placement temperature to 60°F if ground-granulated blast furnace (GGBF) slag is used in the concrete.
 - When used in a bridge slab or in the top slab of a direct-traffic culvert, place Class CO, DC, or S concrete only when its temperature at the time of placement is between 50 and 85°F. Increase the minimum placement temperature to 60°F if GGBF slag is used in the concrete. The maximum temperature increases to 95°F if these classes are used for other applications.
 - Place Class A, B, and D concrete only when its temperature at the time of placement is greater than 50°F.
 - Place mass concrete, defined by Section 420.4.G.14, “Mass Placements,” only when its temperature at the time of placement is between 50 and 75°F.
2. **Transporting Time.** Place concrete delivered in agitating trucks within 60 min. after batching. Place concrete delivered in non-agitating equipment within 45 min. after batching. Revise the concrete mix design as necessary for hot weather or other conditions that contribute to quick setting of the concrete. Submit for approval a plan to demonstrate that these time limitations can be extended while ensuring the concrete can be properly placed, consolidated, and finished without the use of additional water.
3. **Workability of Concrete.** Place concrete with a slump as specified in Section 421.4.A.5, “Slump.” Concrete that exceeds the maximum slump will be rejected. Water may be added to the concrete before discharging any concrete from the truck to adjust for low slump provided that the maximum mix design water–cement ratio is not exceeded. After introduction of any additional water or chemical admixtures, mix concrete in accordance with Section 421.4.E, “Mixing and Delivering Concrete.” Do not add water or chemical admixtures after any concrete has been discharged.
4. **Transporting Concrete.** Use a method and equipment capable of maintaining the rate of placement shown on the plans or required by this Item to transport concrete to the forms. Transport concrete

by buckets, chutes, buggies, belt conveyors, pumps, or other methods.

Protect concrete transported by conveyors from sun and wind to prevent loss of slump and workability. Shade or wrap with wet burlap pipes through which concrete is pumped as necessary to prevent loss of slump and workability.

Arrange and use chutes, troughs, conveyors, or pipes so that the concrete ingredients will not be separated. When necessary to prevent segregation, terminate such equipment in vertical downspouts. Extend open troughs and chutes, if necessary, down inside the forms or through holes left in the forms.

Keep all transporting equipment clean and free from hardened concrete coatings. Discharge water used for cleaning clear of the concrete.

5. **Preparation of Surfaces.** Thoroughly wet all forms, prestressed concrete panels, T-beams, and concrete box beams on which concrete is to be placed before placing concrete on them. Remove any remaining puddles of excess water before placing concrete. Provide surfaces that are in a moist, saturated surface-dry condition when concrete is placed on them.

Ensure that the subgrade or foundation is moist before placing concrete for bridge approach slabs or other concrete placed on grade. Lightly sprinkle the subgrade if dry.

6. **Expansion Joints.** Construct joints and devices to provide for expansion and contraction in accordance with plan details and the requirements of this Section and Item 454, "Bridge Expansion Joints."

Prevent bridging of concrete or mortar around expansion joint material in bearings and expansion joints.

Use forms adaptable to loosening or early removal in construction of all open joints and joints to be filled with expansion joint material. To avoid expansion or contraction damage to the adjacent concrete, loosen these forms as soon as possible after final concrete set to permit free movement of the span without requiring full form removal.

When the plans show a Type A joint, provide preformed fiber joint material in the vertical joints of the roadway slab, curb, median, or sidewalk, and fill the top 1 in. with the specified joint sealing material unless noted otherwise. Install the sealer in accordance

420.4 to 420.4

with Item 438, “Cleaning and Sealing Joints and Cracks (Rigid Pavement and Bridge Decks),” and the manufacturer’s recommendations.

Use light wire or nails to anchor any preformed fiber joint material to the concrete on 1 side of the joint.

Ensure that finished joints conform to the plan details with the concrete sections completely separated by the specified opening or joint material.

Remove all concrete within the joint opening soon after form removal and again where necessary after surface finishing to ensure full effectiveness of the expansion joint.

- 7. Construction Joints.** A construction joint is the joint formed by placing plastic concrete in direct contact with concrete that has attained its initial set. Monolithic placement means that the manner and sequence of concrete placing does not create a construction joint.

Make construction joints of the type and at the locations shown on the plans. Do not make joints in bridge slabs not shown on the plans unless approved. Additional joints in other members are not permitted without approval. Place authorized additional joints using details equivalent to those shown on the plans for joints in similar locations.

Unless otherwise required, make construction joints square and normal to the forms. Use bulkheads in the forms for all vertical joints.

Thoroughly roughen the top surface of a concrete placement terminating at a horizontal construction joint as soon as practical after initial set is attained.

Thoroughly clean the hardened concrete surface of all loose material, laitance, dirt, and foreign matter, and saturate it with water. Remove all free water and moisten the surface before concrete or bonding grout is placed against it.

Draw forms tight against the existing concrete to avoid mortar loss and offsets at joints.

Coat the joint surface with bonding mortar, grout, epoxy, or other material as indicated in the plans or other Items. Provide Type V epoxy per DMS-6100, “Epoxies and Adhesives,” for bonding fresh concrete to hardened concrete. Place the bonding epoxy on a clean,

dry surface, and place the fresh concrete while the epoxy is still tacky. Place bonding mortar or grout on a surface that is saturated surface-dry, and place the concrete before the bonding mortar or grout dries. Place other bonding agents in accordance with the manufacturer's recommendations.

8. **Handling and Placing.** Minimize segregation of the concrete and displacement of the reinforcement when handling and placing concrete. Produce a uniform dense compact mass.

Do not allow concrete to free-fall more than 5 ft. except in the case of drilled shafts, thin walls such as in culverts, or as allowed by other Items. Remove any hardened concrete splatter ahead of the plastic concrete.

Fill each part of the forms by depositing concrete as near its final position as possible. Do not deposit large quantities at 1 point and run or work the concrete along the forms.

Deposit concrete in the forms in layers of suitable depth but not more than 36 in. deep unless otherwise permitted.

Avoid cold joints in a monolithic placement. Sequence successive layers or adjacent portions of concrete so that they can be vibrated into a homogeneous mass with the previously placed concrete before it sets. When re-vibration of the concrete is shown on the plans, allow at most 1 hr. to elapse between adjacent or successive placements of concrete except as otherwise allowed by an approved placing procedure. This time limit may be extended by 1/2 hr. if the concrete contains at least a normal dosage of retarding admixture.

Use an approved retarding agent to control stress cracks and cold joints in placements where differential settlement and setting time may induce cracking.

9. **Consolidation.** Carefully consolidate concrete and flush mortar to the form surfaces with immersion type vibrators. Do not use vibrators that operate by attachment to forms or reinforcement except where approved on steel forms.

Vibrate the concrete immediately after deposit. Systematically space points of vibration to ensure complete consolidation and thorough working of the concrete around the reinforcement, embedded fixtures, and into the corners and angles of the forms. Insert the vibrator vertically where possible except for slabs where it may be inserted in a sloping or horizontal position. Vibrate the

entire depth of each lift, allowing the vibrator to penetrate several inches into the preceding lift. Do not use the vibrator to move the concrete to other locations in the forms. Do not drag the vibrator through the concrete. Thoroughly consolidate concrete along construction joints by operating the vibrator along and close to but not against the joint surface. Continue the vibration until the concrete surrounding reinforcements and fixtures is completely consolidated. Hand-spade or rod the concrete if necessary to ensure flushing of mortar to the surface of all forms.

- 10. Installation of Dowels and Anchor Bolts.** Install dowels and anchor bolts by casting them in-place or by grouting with grout, epoxy, or epoxy mortar unless noted otherwise. Form or drill holes for grouting.

Drill holes for anchor bolts to accommodate the bolt embedment required by the plans. Make holes for dowels at least 12 in. deep unless otherwise shown on the plans. When using grout or epoxy mortar, make the diameter of the hole at least twice the dowel or bolt diameter, but the hole need not exceed the dowel or bolt diameter plus 1-1/2 in. When using epoxy, make the hole diameter 1/16 to 1/4 in. greater than the dowel or bolt diameter.

Thoroughly clean holes of all loose material, oil, grease, or other bond-breaking substance, and blow them clean with filtered compressed air. Ensure that holes are in a surface dry condition when epoxy type material is used and in a surface moist condition when hydraulic cement grout is used. Develop and demonstrate for approval a procedure for cleaning and preparing the holes for installation of the dowels and anchor bolts. Completely fill the void between the hole and dowel or bolt with grouting material. Follow exactly the requirements for cleaning outlined in the product specifications for prepackaged systems.

For cast-in-place or grouted systems, provide hydraulic cement grout in accordance with Section 421.2.F, "Mortar and Grout," epoxy, epoxy mortar, or other prepackaged grouts as approved. Provide a Type III epoxy per DMS-6100, "Epoxies and Adhesives," when neat epoxy is used for anchor bolts or dowels. Provide Type VIII epoxy per DMS-6100 when an epoxy grout is used. Provide grout, epoxy, or epoxy mortar as the binding agent unless otherwise indicated on the plans.

Provide other anchor systems as required in the plans.

- 11. Placing Concrete in Cold Weather.** Protect concrete placed under weather conditions where weather may adversely affect results. Permission given by the Engineer for placing during cold weather does not relieve the Contractor of responsibility for producing concrete equal in quality to that placed under normal conditions. If concrete placed under poor conditions is unsatisfactory, remove and replace it as directed at Contractor's expense.

Do not place concrete in contact with any material coated with frost or having a temperature of 32°F or lower. Do not place concrete when the ambient temperature in the shade is below 40°F and falling unless approved. Concrete may be placed when the ambient temperature in the shade is 35°F and rising or above 40°F.

Provide and install recording thermometers, maturity meters, or other suitable temperature measuring devices to verify that all concrete is effectively protected as follows:

- Maintain the temperature of the top surface of bridge slabs and top slabs of direct-traffic culverts at 50°F or above for 72 hr. from the time of placement and above 40°F for an additional 72 hr.
- Maintain the temperature at all surfaces of concrete in bents, piers, culvert walls, retaining walls, parapets, wingwalls, bottoms of bridge slab or culvert top slabs, and other similar formed concrete at 40°F or above for 72 hr. from the time of placement.
- Maintain the temperature of all other concrete, including the bottom slabs (footings) of culverts, placed on or in the ground above 32°F for 72 hr. from the time of placement.

Use additional covering, insulated forms, or other means and, if necessary, supplement the covering with artificial heating. Avoid applying heat directly to concrete surfaces. Cure as specified in Section 420.4.J, "Curing Concrete," during this period until all requirements for curing have been satisfied.

When impending weather conditions indicate the possible need for temperature protection, have on hand all necessary heating and covering material, ready for use, before permission is granted to begin placement.

- 12. Placing Concrete in Hot Weather.** Use an approved retarding agent in all concrete for superstructures and top slabs of direct-

420.4 to 420.4

traffic culverts, except concrete containing GGBF slag, when the temperature of the air is above 85°F unless otherwise directed.

Keep the concrete at or below the maximum temperature at time of placement as specified in Section 420.4.G.1, "Placing Temperature." Sprinkle and shade aggregate stockpiles or use ice, liquid nitrogen systems, or other approved methods as necessary to control the concrete temperature.

- 13. Placing Concrete in Water.** Deposit concrete in water only when shown on the plans or with approval. Make forms or cofferdams tight enough to prevent any water current passing through the space in which the concrete is being deposited. Do not pump water during the concrete placing or until the concrete has set for at least 36 hr.

Place the concrete with a tremie or pump, or use another approved method, and do not allow it to fall freely through the water or disturb it after it is placed. Keep the concrete surface approximately level during placement.

Support the tremie or operate the pump so that it can be easily moved horizontally to cover all the work area and vertically to control the concrete flow. Submerge the lower end of the tremie or pump hose in the concrete at all times. Use continuous placing operations until the work is complete.

For concrete to be placed under water, design the concrete mix in accordance with Item 421, "Hydraulic Cement Concrete," with a minimum cement content of 650 lb. per cubic yard. Include an anti-washout admixture in the mix design as necessary to produce a satisfactory finished product.

- 14. Mass Placements.** Mass placements are defined as placements with a least dimension greater than or equal to 5 ft., or designated on the plans. For monolithic mass placements, develop and obtain approval for a plan to ensure the following during the heat dissipation period:

- the temperature differential between the central core of the placement and the exposed concrete surface does not exceed 35°F and
- the temperature at the central core of the placement does not exceed 160°F.

Base this plan on the equations given in the Portland Cement Association's *Design and Control of Concrete Mixtures*. Cease all

mass placement operations and revise the plan as necessary if either of the above limitations is exceeded.

Include a combination of the following elements in this plan:

- selection of concrete ingredients including aggregates, gradation, and cement types, to minimize heat of hydration;
- use of ice or other concrete cooling ingredients;
- use of liquid nitrogen dosing systems;
- controlling rate or time of concrete placement;
- use of insulation or supplemental external heat to control heat loss;
- use of supplementary cementing materials; or
- use of a cooling system to control the core temperature.

Furnish and install 2 sets of temperature recording devices, maturity meters, or other approved equivalent devices at designated locations. Use these devices to simultaneously measure the temperature of the concrete at the core and the surface. Maintain temperature control methods for 4 days unless otherwise approved. Maturity meters may not be used to predict strength of mass concrete.

- 15. Placing Concrete in Foundation and Substructure.** Do not place concrete in footings until the depth and character of the foundation has been inspected and permission has been given to proceed.

Placing of concrete footings upon seal concrete is permitted after the cofferdams are free from water and the seal concrete cleaned. Perform any necessary pumping or bailing during the concreting from a suitable sump located outside the forms.

Construct or adjust all temporary wales or braces inside cofferdams as the work proceeds to prevent unauthorized construction joints.

When footings can be placed in a dry excavation without the use of cofferdams, omit forms if approved, and fill the entire excavation with concrete to the elevation of the top of footing.

Place concrete in columns monolithically between construction joints unless otherwise directed. Columns and caps or tie beams supported on them may be placed in the same operation or separately. If placed in the same operation, allow for settlement and shrinkage of the column concrete by placing it to the lower level of the cap or tie beam, and delay placement between 1 and 2 hr. before proceeding with the cap or tie beam placement.

- 16. Placing Concrete in Box Culverts.** Where the top slab and walls are placed monolithically in culverts more than 4 ft. in clear height, allow between 1 and 2 hr. to elapse before placing the top slab to allow for settlement and shrinkage in the wall concrete.

Accurately finish the footing slab at the proper time to provide a smooth uniform surface. Finish top slabs that carry direct-traffic as specified in this Item. Give top slabs of fill type culverts a float finish.

- 17. Placing Concrete in Superstructure.** Unless otherwise shown on the plans, place simple span bridge slabs without transverse construction joints by using either a self-propelled transverse finishing machine or a mechanical longitudinal screed. For small placements or for unusual conditions such as narrow widening, variable cross-slopes, or transitions, use of manually operated screeding equipment may be permitted. Support the screed adequately on a header or rail system stable enough to withstand the longitudinal or lateral thrust of the equipment. Adjust the profile grade line as necessary to account for variations in beam camber and other factors to obtain the required slab thickness and concrete cover over the slab reinforcement. Set beams and verify their surface elevations in a sufficient number of spans so that when adjustment is necessary, the profile grade line can be adjusted over suitable increments to produce a smooth riding surface. Take dead load deflection into account in setting the grades of headers and rail systems. Use construction joints, when required or permitted for slab placements on steel or prestressed concrete beams, as shown on the plans. Before placing concrete on steel girder or truss spans, release falsework under the spans and swing the spans free on their permanent supports.

Make 1 or more passes with the screed over the bridge slab segment before placing concrete on it to ensure proper operation and maintenance of grades and clearances. Use an approved system of checking to detect any vertical movement of the forms or falsework. Maintain forms for the bottom surface of concrete slabs, girders, and overhangs to the required vertical alignment during concrete placing.

Fog unformed surfaces of slab concrete in bridge slabs and in top slabs of direct-traffic culverts from the time of initial strikeoff of the concrete until finishing is completed and required interim curing is in place. Do not use fogging as a means to add finishing

water, and do not work moisture from the fog spray into the fresh concrete.

For simple spans, retard the concrete only if necessary to complete finishing operations or as required by this Section. When filling curb forms, bring the top of curb and sidewalk section to the correct camber and alignment, and finish them as described in this Item.

- a. Transverse Screeding.** Install rails for transverse finishing machines that are supported from the beams or girders so that the supports may be removed without damage to the slab. Prevent bonding between removable supports and the concrete in an acceptable manner. Do not allow rail support parts that remain embedded in the slab to project above the upper mat of reinforcing steel. Rail or screed supports attached to I-beams or girders are subject to the requirements of this Item. Unless otherwise shown on the plans, for transverse screeding the minimum rate of concrete placement is 30 linear feet of bridge slab per hour. Deposit concrete parallel to the skew of the bridge so that all girders are loaded uniformly along their length. Deposit slab concrete between the exterior beam and the adjacent beam before placing concrete in the overhang portion of the slab. Furnish personnel and equipment capable of placing, finishing, and curing the slab at an acceptable rate to ensure compliance with the specifications. Place concrete in transverse strips. On profile grades greater than 1-1/2%, start placement at the lowest end.
- b. Longitudinal Screeding.** Unless otherwise shown on the plans, use of temporary intermediate headers will be permitted for placements over 50 ft. long if the rate of placement is rapid enough to prevent a cold joint and if these headers are designed for easy removal to permit satisfactory consolidation and finish of the concrete at their locations. Deposit slab concrete between the exterior beam and the adjacent beam before placing concrete in the overhang portion of the slab. Place concrete in longitudinal strips starting at a point in the center of the segment adjacent to 1 side except as this Section indicates, and complete the strip by placing uniformly in both directions toward the ends. For spans on a profile grade of 1-1/2% or more, start placing at the lowest end. Use strips wide enough that the concrete within each strip remains plastic until placement of the adjacent strip. Where monolithic curb

construction is specified, place the concrete in proper sequence to be monolithic with the adjacent longitudinal strips of the slabs.

- c. **Placements on Continuous Steel Units.** Unless otherwise shown on the plans, place slabs on continuous steel units in a single continuous operation without transverse construction joints using a self-propelled transverse finishing machine or a mechanical longitudinal screed. Retard the initial set of the concrete sufficiently to ensure that concrete remains plastic in at least 3 spans immediately preceding the slab being placed. Use construction joints, when required for slab placements on steel beams or girders, as shown on the plans. When staged placement of a slab is required in the plans, ensure that the previously placed concrete attains a compressive strength of 3,000 psi before placing the next stage concrete. Multiple stages may be placed in a single day if approved. Where plans permit staged placing without specifying a particular order of placement, use an approved placing sequence that will not overstress of any of the supporting members.
- d. **Slab and Girder Units.** Unless otherwise shown on the plans, place girders, slab, and curbs of slab and girder spans monolithically. Fill concrete girder stems first, and place the slab concrete within the time limits specified in this Item. If using a transverse screed, place concrete in the stems for a short distance and then place the concrete in transverse strips. If using a longitudinal screed, fill the outside girder stem first, beginning at the low end or side, and continue placement in longitudinal strips.

H. Treatment and Finishing of Horizontal Surfaces Other Than Bridge Slabs. Strike off to grade and finish all unformed upper surfaces. Do not use mortar topping for surfaces constructed under this Section.

After the concrete has been struck off, float the surface with a suitable float. Give bridge sidewalks a wood float or broom finish, or stripe them with a brush.

Slightly slope the tops of caps and piers between bearing areas from the center toward the edge, and slope the tops of abutment and transition bent caps from the backwall to the edge, as directed, so that water drains from the surface. Give the concrete a smooth trowel finish. Construct bearing areas for steel units in accordance with

Section 441.3.K.5, "Bearing and Anchorage Devices." Give the bearing area under the expansion ends of concrete slabs and slab and girder spans a steel-trowel finish to the exact grades required. Give bearing areas under elastomeric bearing pads or nonreinforced bearing seat buildups a textured, wood float finish. Do not allow the bearing area to vary from a level plane more than 1/16 in. in all directions.

Cast bearing seat buildups or pedestals for concrete units integrally with the cap or with a construction joint. Provide a latex-based mortar, an epoxy mortar, or an approved proprietary bearing mortar for bearing seat buildups cast with a construction joint. Mix mortars in accordance with the manufacturer's recommendations. Construct pedestals of Class C concrete, reinforced as shown on the plans or as indicated in Figure 1 and Figure 2.

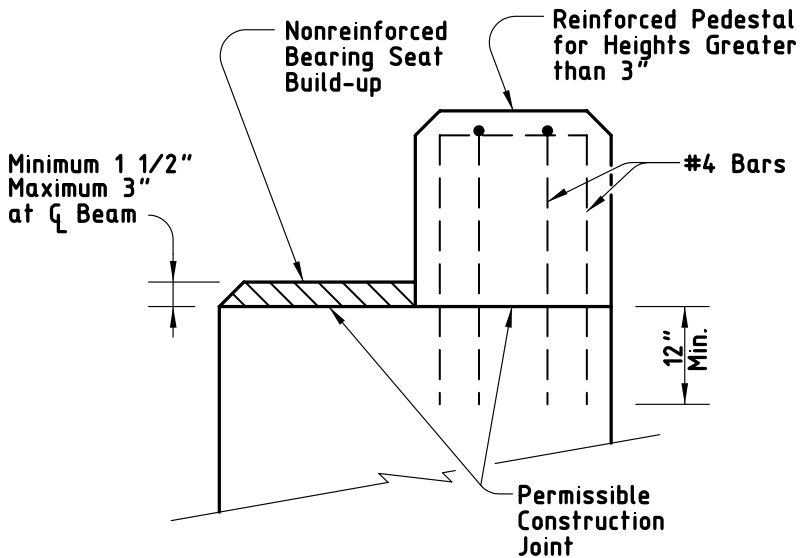

Figure 1
Section through bearing seat buildups.

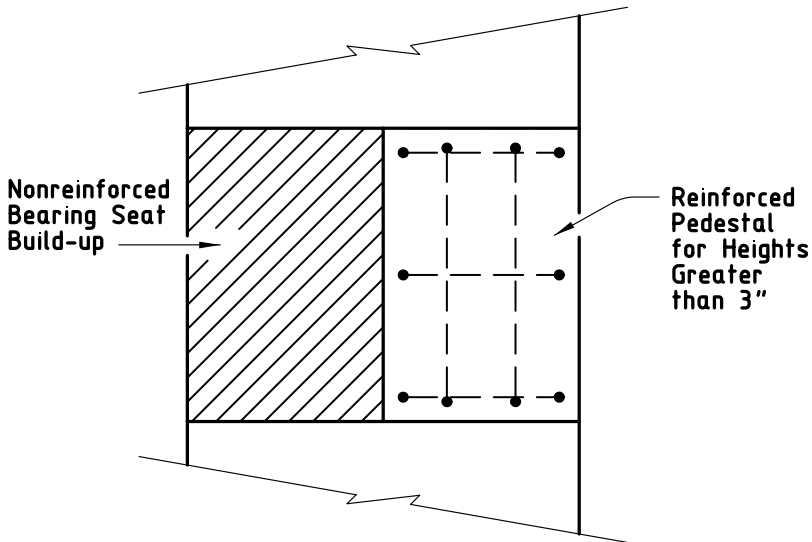

Figure 2
Plan view of bearing seat buildups.

I. Finish of Bridge Slabs. Provide camber for specified vertical curvature and transverse slopes.

For concrete flat slab and concrete slab and girder spans cast in place on falsework, provide additional camber to offset the initial and final deflections of the span as indicated in the plans. For concrete slab and girder spans using pan forms, provide camber of approximately $\frac{3}{8}$ in. for 30-ft. spans and $\frac{1}{2}$ in. for 40-ft. spans to offset initial and final deflections unless otherwise directed. For concrete flat slab and concrete slab and girder spans not using pan forms, when dead load deflection is not shown on the plans, provide a camber of $\frac{1}{8}$ in. per 10 ft. of span length but no more than $\frac{1}{2}$ in.

Provide a camber of $\frac{1}{4}$ in. in addition to deflection for slabs without vertical curvature on steel or prestressed concrete beams.

Use work bridges or other suitable facilities to perform all finishing operations and to provide access, if necessary, for the Engineer to check measurements for slab thickness and reinforcement cover.

As soon as the concrete has been placed and vibrated in a section wide enough to permit working, level, strike off, and screed the surface, carrying a slight excess of concrete ahead of the screed to fill all low spots.

Move longitudinal screeds across the concrete with a saw-like motion while their ends rest on headers or templates set true to the roadway grade or on the adjacent finished slab. Move transverse screeds longitudinally approximately 1/5 of the drum length for each complete out-and-back pass of the carriage.

Screed the surface of the concrete enough times and at intervals to produce a uniform surface true to grade and free of voids.

Work the screeded surface to a smooth finish with a long-handled wood or metal float or hand-float it from work bridges over the slab. Floating may not be necessary if the pan float attached to a transverse screed produces an acceptable finish. Avoid overworking the surface of the concrete. Avoid overuse of finish water.

Perform sufficient checks, witnessed by the Engineer, with a long-handled 16-ft. straightedge on the plastic concrete to ensure that the final surface will be within specified tolerances. Make the check with the straightedge parallel to the centerline. Lap each pass half over the preceding pass. Remove all high spots, and fill and float all depressions over 1/16 in. deep with fresh concrete. Continue checking and floating until the surface is true to grade and free of depressions, high spots, voids, or rough spots. Fill screed-rail support holes with concrete, and finish them to match the top of the slab.

Finish the concrete surface to a uniform texture using a carpet drag, burlap drag, or broom finish. Finish the surface to a smooth sandy texture without blemishes, marks, or scratches deeper than 1/16 in. Apply the surface texturing using a work bridge or platform immediately after completing the straightedge checks. Draw the carpet or burlap drag longitudinally along the concrete surface, adjusting the surface contact area or pressure to provide a satisfactory coarsely textured surface. A broom finish may be performed using a fine bristle broom transversely.

Coat the concrete surface immediately after the carpet or burlap drag, or broom finish with a single application of evaporation retardant at a rate recommended by the manufacturer. Do not allow more than 10 min. to elapse between the texturing at any location and application of evaporation retardant. The evaporation retardant may be applied

420.4 to 420.4

using the same work bridge used for surface texturing. Do not work the concrete surface once the evaporation retardant has been applied.

Apply interim and final curing in accordance with Section 420.4.J, "Curing Concrete."

The Contractor is responsible for the ride quality of the finished bridge slab. The Engineer will use a 10-ft. straightedge (1/8 in. in 10 ft.) to verify ride quality and to determine locations where corrections are needed. If the Engineer determines that the ride quality is unacceptable, submit a plan for approval to produce a ride of acceptable quality. Make all corrections for ride before saw-cutting grooves.

Saw-cut grooves in the hardened concrete of bridge slabs, bridge approach slabs, and direct-traffic culverts to produce the final texturing after completion of the required curing period. Cut grooves perpendicular to the structure centerline. Cut grooves continuously across the slab to within 18 in. of the barrier rail, curb, or median divider. At skewed metal expansion joints in bridge slabs, adjust groove cutting by using narrow-width cutting heads so that all grooves end within 6 in. of the joint, measured perpendicular to the centerline of the metal joint. Leave no ungrooved surface wider than 6 in. adjacent to either side of the joint. Ensure that the minimum distance to the first groove, measured perpendicular to the edge of the concrete joint or from the junction between the concrete and the metal leg of the joint, is 1 in. Cut grooves continuously across construction joints or other joints in the concrete that are less than 1/2 in. wide. Apply the same procedure described above where barrier rails, curbs, or median dividers are not parallel to the structure centerline to maintain the 18-in. maximum dimension from the end of the grooves to the gutter line. Cut grooves continuously across formed concrete joints.

When the plans call for a concrete overlay to be placed on the slab (new construction) or on prestressed concrete box beams or other precast elements, give a carpet drag, burlap drag, or broom finish to all concrete surfaces to be overlaid. Saw-grooving is not required in this case. Provide an average texture depth for the finish of approximately 0.035 in. with no individual test falling below 0.020 in., unless otherwise shown on the plans, when tested in accordance with Tex-436-A. If the texture depth falls below what is intended, revise finishing procedures to produce the desired texture.

When the plans require an asphalt seal, with or without overlay, on the slab (new construction), on prestressed concrete box beams, or on other precast elements, give all concrete surfaces to be covered a lightly

textured broom or carpet drag finish. Provide an average texture depth of approximately 0.025 in. when tested in accordance with Tex-436-A.

- J. Curing Concrete.** Obtain approval of the proposed curing methods, equipment, and materials before placing concrete. The Engineer may require the same curing methods for like portions of a single structure. Inadequate curing or facilities may delay all concrete placement on the job until remedial action is taken.

A curing day is a calendar day when the temperature, taken in the shade away from artificial heat, is above 50°F for at least 19 hr. or, on colder days if the temperature of all surfaces of the concrete is maintained above 40°F, for the entire 24 hr. The required curing period begins when all concrete has attained its initial set. Tex-440-A may be used to determine when the concrete has attained its initial set.

Cure all concrete for 4 consecutive days except as noted in Table 1.

Table 1
Exceptions to 4-Day Curing

Description	Type of Cement	Required Curing Days
Upper surfaces of bridge slabs, top slab of direct-traffic culverts, and concrete overlays	I or III	8
	II or I/II	10
	All types with supplementary cementing materials	10
Concrete piling buildups	All	6

For upper surfaces of bridge slabs, bridge approach slabs, median and sidewalk slabs, and culvert top slabs constructed using Class S concrete, apply interim curing using a Type 1-D curing compound as soon as possible after application of the evaporation retardant and after the water sheen has disappeared, but no more than 45 min. after application of the evaporation retardant. Apply membrane interim curing using a work bridge or other approved apparatus to ensure a uniform application. Water-cure for final curing in accordance with this Section, starting as soon as possible without damaging the surface finish. Maintain the water curing for the duration noted in Table 1. Place polyethylene sheeting, burlap-polyethylene blankets, laminated mats, or insulating curing mats in direct contact with the slab when the air temperature is expected to drop below 40°F during the first 72 hr. of the curing period. Weigh down these curing materials with dry mats to maintain direct contact with the concrete and to provide insulation

420.4 to 420.4

against cold weather. Supplemental heating or insulation may be required in cold and wet weather if the insulating cotton mats become wet or if the concrete drops below the specified curing temperature. Avoid applying heat directly to concrete surfaces.

For the top surface of any concrete unit upon which concrete is to be placed and bonded at a later interval (stub walls, risers, etc.) and other superstructure concrete (curbs, wingwalls, parapet walls, etc.), use only water curing in accordance with this Section.

Cure all other concrete as specified in the pertinent Items. Use the following methods for curing concrete, subject to the requirements of this Item.

1. **Form Curing.** When forms are left in intimate contact with the concrete, other curing methods are not required except for exposed surfaces and for cold weather protection. If forms are removed before the 4-day required curing period, use another approved curing method.
2. **Water Curing.** Keep all exposed surfaces of the concrete wet continuously for the required curing time. Use water curing that meets the requirements for concrete mixing water in Section 421.2.D, "Water." Do not use seawater or water that stains or leaves an unsightly residue.
 - a. **Wet Mats.** Keep the concrete continuously wet by maintaining wet cotton mats in direct contact with the concrete for the required curing time. If needed, place damp burlap blankets made from 9-oz. stock on the damp concrete surface for temporary protection before applying cotton mats. Then place the dry mats and wet them immediately after they are placed. Weight the mats adequately to provide continuous contact with all concrete. Cover surfaces that cannot be cured by direct contact with mats, forming an enclosure well anchored to the forms or ground so that outside air cannot enter the enclosure. Provide sufficient moisture inside the enclosure to keep all surfaces of the concrete wet.
 - b. **Water Spray.** Overlap sprays or sprinklers to keep all unformed surfaces continuously wet.
 - c. **Ponding.** Cover the surfaces with at least 2 in. of clean granular material, kept wet at all times, or at least 1 in. deep water. Use a dam to retain the water or saturated granular material.

3. **Membrane Curing.** Unless otherwise shown on the plans, choose either Type 1-D or Type 2 membrane-curing compound when membrane curing is permitted. Type 1-D (Resin Base Only) is required for interim curing bridge slabs and top slabs of direct-traffic culverts and all other surfaces that require a higher grade of surface finish. For substructure concrete provide only 1 type of curing compound on any 1 structure.

Apply membrane curing just after free moisture has disappeared at a rate of approximately 180 sq. ft. per gallon. Do not spray curing compound on projecting reinforcing steel or concrete that will later form a construction joint. Do not apply membrane curing to dry surfaces. Dampen formed surfaces and surfaces that have been given a first rub so that they are moist at the time of application of the membrane.

When membrane is used for complete curing, leave the film unbroken for the minimum curing period specified. Correct damaged membrane immediately by reapplication of membrane. Polyethylene sheeting, burlap-polyethylene mats, or laminated mats in close contact with the concrete surfaces are equivalent to membrane curing.

- K. **Removal of Forms and Falsework.** Unless otherwise directed, forms for vertical surfaces may be removed after the concrete has aged 12 hr. after initial set provided the removal can be done without damage to the concrete. Keep forms for mass placements, defined in Section 420.4.G.14, "Mass Placements," in place for 4 days following concrete placement.

Remove forms for inside curb faces and for bridge rails whenever removal can be done without damage to the curb or railing.

Leave in place weight-supporting forms and falsework spanning more than 1 ft. for all bridge components and culvert slabs except as directed otherwise until the concrete has attained a compressive strength of 2,500 psi. Remove forms for other structural components as necessary.

Remove inside forms (walls and top slabs) for box culverts and sewers after concrete has attained a compressive strength of 1,800 psi if an approved overhead support system is used to transfer the weight of the top slab to the walls of the box culvert or sewer before removal of the support provided by the forms.

420.4 to 420.4

Forms or parts of forms may be removed only if constructed to permit removal without disturbing forms or falsework required to be left in place for a longer period on other portions of the structure.

Remove all metal appliances used inside forms for alignment to a depth of at least 1/2 in. from the concrete surface. Make the appliances so that metal may be removed without undue chipping or spalling of the concrete, and so that it leaves a smooth opening in the concrete surface when removed. Do not burn off rods, bolts, or ties.

Remove all forms and falsework unless otherwise directed.

- L. Defective Work.** Repair defective work as soon as possible. Remove and replace at the expense of the Contractor any defect that cannot be repaired to the satisfaction of the Engineer.
- M. Ordinary Surface Finish.** Apply an ordinary surface finish to all concrete surfaces as follows:
- Chip away all loose or broken material to sound concrete where porous, spalled, or honeycombed areas are visible after form removal.
 - Repair spalls by saw-cutting and chipping at least 1/2 in. deep, perpendicular to the surface to eliminate feather edges. Repair shallow cavities using a latex adhesive grout, cement mortar, or epoxy mortar as approved. Repair large areas using concrete as directed or approved.
 - Clean and fill holes or spalls caused by the removal of form ties, etc., with latex grout, cement grout, or epoxy grout as approved. Fill only the holes. Do not blend the patch with the surrounding concrete. On surfaces to receive a rub finish in accordance with Item 427, "Surface Finishes for Concrete," chip out exposed parts of metals chairs to a depth of 1/2 in. and repair the surface.
 - Remove all fins, runs, drips, or mortar from surfaces that will be exposed. Smooth all form marks and chamfer edges by grinding or dry-rubbing.
 - Ensure that all repairs are dense, well bonded, and properly cured. Finish exposed large repairs to blend with the surrounding concrete where a higher class of finish is not specified.

Unless noted otherwise, apply an ordinary surface finish as the final finish to the following exposed surfaces:

- inside and top of inlets,
- inside and top of manholes,
- inside of sewer appurtenances,
- inside of culvert barrels,

- bottom of bridge slabs between girders or beams, and
- vertical and bottom surfaces of interior concrete beams or girders.

Form marks and chamfer edges do not need to be smoothed for the inside of culvert barrels and the bottom of bridge slabs between girders or beams.

420.5. Measurement. This Item will be measured by the cubic yard, square yard, foot, square foot, or by each structure.

A. General. Concrete quantities will be based on the dimensions shown on the plans or those established in writing by the Engineer.

In determining quantities, no deductions will be made for chamfers less than 2 in. or for embedded portions of steel or prestressed concrete beams, piling, anchor bolts, reinforcing steel, drains, weep holes, junction boxes, electrical or telephone conduit, ducts and voids for prestressed tendons, or embedded portions of light fixtures.

For slab and girder spans using pan forms, a quantity will be included for the screed setting required to provide proper camber in the roadway surface after form removal.

For slabs on steel or prestressed concrete beams, an estimated quantity for the haunch between the slab and beams will be included. No measurement will be made during construction for variation in the amount of haunch concrete due to variations in camber of the beams.

For cast-in-place slabs on slab beams, double-T beams, or box beams, the combination of span length, theoretical camber in beams, computed deflections, and plan vertical curve will be taken into account in determining the quantity for the slab.

Additional concrete that may be required by an adjustment of the profile grade line during construction, to insure proper slab thickness, will not be measured for payment.

Variation in concrete headwall quantity incurred when an alternate bid for pipe is permitted will not be cause for payment adjustment.

Mass placements may be either a plans quantity item or measured in place as indicated.

Quantities revised by a change in design, measured as specified, will be increased or decreased and included for payment.

B. Plans Quantity. Structure elements designated in Table 2 and measured by the cubic yard are plans quantity measurement items. The quantity to be paid for plans quantity items is the quantity shown in the

420.6 to 420.6

proposal unless modified by Article 9.2, “Plans Quantity Measurement.” Additional measurements or calculations will be made if adjustments of quantities are required.

No adjustment will be made for footings or other in-ground elements where the Contractor has been allowed to place concrete in an excavation without forms.

**Table 2
Plans Quantity Payment
(Cubic Yard Measurement Only)**

Culverts and culvert wing walls	Abutments
Headwalls for pipe	Slab and girder spans (pan form)
Retaining walls	Footings
Inlets and manholes	Pile bent caps
Shear key concrete for box and slab beams	Concrete wearing surface on pre-cast box beams, slab beams or double-T beams
Bridge approach slabs	Cast-in-place concrete slab spans

Note: Other structure elements, including pier and bent concrete, may be paid for as “plans quantity” when shown on the plans.

C. Measured in Place. Items not paid for as “plans quantity” will be measured in place.

420.6. Payment. The work performed and materials furnished in accordance with this Item and measured as provided under “Measurement” will be paid for at the unit price bid for the various structure elements specified of the various classes of concrete. Mass placements, as defined in Section 420.4.G.14, “Mass Placements,” will be paid for separately for the various classes of concrete. This price is full compensation for furnishing, hauling, and mixing concrete materials; furnishing, bending, fabricating, splicing, welding and placing the required reinforcement; clips, blocks, metal spacers, ties, wire, or other materials used for fastening reinforcement in place; placing, finishing, curing, and grooving concrete; applying ordinary surface finish; furnishing and placing drains, metal flashing strips, and expansion-joint material; excavation, subgrade preparation, and disposal of excavated material for bridge approach slabs; and forms and falsework, equipment, labor, tools, and incidentals.

Diaphragm concrete will not be paid for directly but is subsidiary to the slab unless otherwise shown on the plans.

Design and installation of foundations for falsework is at the Contractor's expense.

The following procedure will be used to evaluate concrete where 1 or more project acceptance test specimens fail to meet the required design strength specified in Item 421, "Hydraulic Cement Concrete," or in the plans:

- The concrete for a given placement will be considered structurally adequate and accepted at full price if the average of all test results for specimens made at the time of placement meets the required design strength provided that no single test result is less than 85% of the required design strength.
- The Engineer will perform a structural review of the concrete to determine its adequacy to remain in service if the average of all test results for specimens made at the time of placement is less than the required design strength or if any test results are less than 85% of the required design strength. If cores are required to determine the strength of the in-situ concrete, take cores at locations designated by the Engineer in accordance with Tex-424-A. The coring and testing of the cores will be at the Contractor's expense. The Engineer will test the cores.
- If all of the tested cores meet the required design strength, the concrete will be paid for at the full price.
- If any of the tested cores do not meet the required design strength but the average strength attained is determined to be structurally adequate, the Engineer will determine the limits of the pay adjustment. The average strength of the cores tested will be used in the pay adjustment formula.
- Remove concrete that is not structurally adequate.
- Concrete that has been determined to be structurally adequate may be accepted at an adjusted price based on the following formula:

$$A = 0.10Bp + 0.75(Sa/Ss)^2 Bp$$

where:

A = Amount to be paid per unit of measure for the entire placement in question

Sa = Actual strength from cylinders or cores. Use values from cores, if taken.

Ss = Minimum required strength (specified)

Bp = Unit bid price.

- The decision to reject structurally inadequate concrete or to apply the pay adjustment will be made no later than 56 days after placement.

421.1 to 421.2

ITEM 421 HYDRAULIC CEMENT CONCRETE

421.1. Description. Furnish hydraulic cement concrete for concrete pavements, concrete structures, and other concrete construction.

421.2. Materials.

- A. Cement.** Furnish cement conforming to DMS-4600, "Hydraulic Cement."
- B. Supplementary Cementing Materials (SCM).**
 - 1. Fly Ash.** Furnish fly ash conforming to DMS-4610, "Fly Ash."
 - 2. Ultra-Fine Fly Ash (UFFA).** Furnish UFFA conforming to DMS-4610, "Fly Ash."
 - 3. Ground Granulated Blast-Furnace Slag (GGBFS).** Furnish GGBFS conforming to DMS-4620, "Ground Granulated Blast-Furnace Slag," Grade 100 or 120.
 - 4. Silica Fume.** Furnish silica fume conforming to DMS-4630, "Silica Fume."
 - 5. Metakaolin.** Furnish metakaolin conforming to DMS-4635, "Metakaolin."
- C. Chemical Admixtures.** Furnish admixtures conforming to DMS-4640, "Chemical Admixtures for Concrete." Do not use calcium chloride.
- D. Water.** Furnish mixing and curing water that is free from oils, acids, organic matter, or other deleterious substances. Water from municipal supplies approved by the Texas Department of Health will not require testing. When using water from other sources, provide test reports showing compliance with Table 1 before use.

Water that is a blend of concrete wash water and other acceptable water sources, certified by the concrete producer as complying with the requirements of both Table 1 and Table 2, may be used as mix water. Test the blended water weekly for 4 weeks for compliance with Table 1 and Table 2 or provide previous test results. Then test every month for compliance. Provide water test results upon request.

Table 1
Chemical Limits for Mix Water

Contaminant	Test Method	Maximum Concentration (ppm)
Chloride (Cl)	ASTM D 512	
Prestressed concrete		500
Bridge decks & superstructure		500
All other concrete		1,000
Sulfate (SO ₄)	ASTM D 516	1,000
Alkalies (Na ₂ O + 0.658K ₂ O)	ASTM D 4191 & ASTM D 4192	600
Total solids	AASHTO T 26	50,000

Table 2
Acceptance Criteria for Questionable Water Supplies

Property	Test Method	Limits
Compressive strength, min % control at 7 days	ASTM C 109 ¹	90
Time of set, deviation from control, Min.	ASTM C 191 ¹	from 60 early to 90 later

1. Base comparisons on fixed proportions and the same volume of test water compared to the control mix using city water or distilled water.

Do not use mix water that has an adverse effect on the air-entraining agent, on any other chemical admixture, or on strength or time of set of the concrete. When using white hydraulic cement, use mixing and curing water free of iron and other impurities that may cause staining or discoloration.

- E. Aggregate.** Supply aggregates that meet the definitions in Tex-100-E. Provide coarse and fine aggregates from sources listed in the Department's Concrete Rated Source Quality Catalog (CRSQC). Provide aggregate from non-listed sources only when tested and approved by the Engineer before use. Allow 30 calendar days for the Engineer to sample, test, and report results for non-listed sources. Do not combine approved material with unapproved material.
- 1. Coarse Aggregate.** Provide coarse aggregate consisting of durable particles of gravel, crushed blast furnace slag, recycled crushed hydraulic cement concrete, crushed stone, or combinations thereof that are free from frozen material and from injurious amounts of salt, alkali, vegetable matter, or other objectionable material, either

421.2 to 421.2

free or as an adherent coating. Provide coarse aggregate of uniform quality throughout.

Provide coarse aggregate that, when tested in accordance with Tex-413-A, has:

- at most 0.25% by weight of clay lumps,
- at most 1.0% by weight of shale, and
- at most 5.0% by weight of laminated and friable particles.

Wear must not be more than 40% when tested in accordance with Tex-410-A.

Unless otherwise shown on the plans, provide coarse aggregate with a 5-cycle magnesium sulfate soundness of not more than 18% when tested in accordance with Tex-411-A. Crushed recycled hydraulic cement concrete is not subject to the 5-cycle soundness test.

The loss by decantation as tested in accordance with Tex-406-A, plus the allowable weight of clay lumps, must not exceed 1.0% or the value shown on the plans, whichever is smaller. In the case of aggregates made primarily from crushing stone, if the material finer than the No. 200 sieve is established to be the dust of fracture and essentially free from clay or shale as established by Tex-406-A, Part III, the limit may be increased to 1.5%. When crushed limestone coarse aggregate is used in concrete pavements, the decant may exceed 1.0% but not more than 3.0% if the material finer than the No. 200 sieve is determined to be at least 67% calcium carbonate in accordance with Tex-406-A, Part III.

Unless otherwise specified, provide aggregate conforming to the gradation requirements shown in Table 3 when tested in accordance with Tex-401-A.

Table 3
Coarse Aggregate Gradation Chart

Aggregate Grade No. ¹	Nominal Size	Percent Passing on Each Sieve									
		2-1/2"	2"	1-1/2"	1"	3/4"	1/2"	3/8"	No. 4	No. 8	
1	2"	100	80-100	50-85		20-40			0-5		
2 (467)	1-1/2"		100	95-100		35-70		10-30	0-5		
3	1-1/2"		100	95-100		60-90	25-60		0-5		
4 (57)	1"			100	95-100		25-60		0-10	0-5	
5 (67)	3/4"				100	90-100		20-55	0-10	0-5	
6 (7)	1/2"					100	90-100	40-70	0-15	0-5	
7	3/8"						100	70-95	0-25		
8	3/8"						100	95-100	20-65	0-10	

1. Corresponding ASTM C 33 gradation shown in parentheses.

- 2. Fine Aggregate.** Provide fine aggregate consisting of clean, hard, durable particles of natural or manufactured sand or a combination thereof with or without mineral filler. Provide fine aggregate free from frozen material and from injurious amounts of salt, alkali, vegetable matter, or other objectionable material, and containing no more than 0.5% clay lumps by weight in accordance with Tex-413-A.

Provide fine aggregate that does not show a color darker than standard when subjected to the color test for organic impurities in accordance with Tex-408-A.

Unless otherwise shown on the plans, use fine aggregate with an acid insoluble residue of at least 60% by weight when tested in accordance with Tex-612-J in all concrete subject to direct traffic.

Unless otherwise shown on the plans, when necessary, blend the fine aggregate to meet the acid insoluble residue requirement.

When blending, use the following equation:

$$\text{Acid Insoluble (\%)} = \{(A1)(P1) + (A2)(P2)\} / 100$$

where:

A1 = acid insoluble (%) of aggregate 1

A2 = acid insoluble (%) of aggregate 2

P1 = percent by weight of *A1* of the fine aggregate blend

P2 = percent by weight of *A2* of the fine aggregate blend.

Provide fine aggregate or combinations of aggregates, including mineral filler, conforming to the gradation requirements shown in

421.3 to 421.3

Table 4 when tested in accordance with Tex-401-A unless otherwise specified.

Table 4
Fine Aggregate Gradation Chart (Grade 1)

Sieve Size	Percent Passing
3/8 in.	100
No. 4	95–100
No. 8	80–100
No. 16	50–85
No. 30	25–65
No. 50	10–35 ¹
No. 100	0–10
No. 200	0–3 ²

1. 6–35 when sand equivalent value is greater than 85.

2. 0–6 for manufactured sand.

Unless otherwise shown on the plans, provide fine aggregate with a sand equivalent of at least 80 in accordance with Tex-203-F.

For all classes of concrete except Class K, provide fine aggregate with a fineness modulus between 2.30 and 3.10 as determined by Tex-402-A. For Class K concrete, provide a fine aggregate with a fineness modulus between 2.60 to 2.80 unless otherwise shown on the plans.

3. **Mineral Filler.** Provide mineral filler consisting of stone dust, clean crushed sand, or other approved inert material with 100% passing the No. 30 sieve and 65 to 100% passing the No. 200 sieve when tested in accordance with Tex-401-A.
- F. Mortar and Grout.** When required or shown on the plans, provide mortar and grout consisting of 1 part hydraulic cement, 2 parts sand, and sufficient water to provide the desired consistency. Provide mortar with a consistency such that the mortar can be easily handled and spread by trowel. Provide grout of a consistency that will flow into and completely fill all voids.

421.3. Equipment.

- A. **Concrete Plants and Mixing Equipment.** Except for volumetric mixers (auger/mixer), each plant and truck mixer must be currently certified by the National Ready Mixed Concrete Association (NRMCA) or have an inspection report signed and sealed by a licensed professional engineer showing that concrete measuring, mixing, and

delivery equipment meets all requirements of ASTM C 94. A new certification or signed and sealed report is required every time a plant is moved. Plants with a licensed engineer's inspection require reinspection every 2 years. Provide a copy of the certification or the signed and sealed inspection report to the Engineer. When equipment or facilities fail to meet specification requirements, remove them from service until corrected.

1. **Scales.** Check all scales prior to beginning of operations, after each move, or whenever their accuracy or adequacy is questioned, and at least once every 6 mo. Immediately correct deficiencies, and recalibrate. Provide a record of calibration showing scales in compliance with ASTM C 94 requirements. Check batching accuracy of volumetric water batching devices and admixture dispensing devices at least every 90 days. Perform daily checks as necessary to ensure measuring accuracy.
2. **Volumetric Mixers.** Provide volumetric mixers with rating plates defining the capacity and the performance of the mixer in accordance with the Volumetric Mixer Manufacturers Bureau or equivalent. Provide volumetric mixers that comply with ASTM C 685. Provide test data showing mixers meet the uniformity test requirements of Tex-472-A.
3. **Agitators and Truck and Stationary Mixers.** Inspect and furnish inspection reports on truck mixers and agitators annually. If an inspection within 12 mo. is not practical, a 2-mo. grace period (for a maximum of 14 mo. between inspections) is permitted. Include in the report the condition of blades and fins and their percent wear from the original manufacturer's design. Repair mixing equipment exhibiting 10% or more wear before use. Provide truck mixers and agitators equipped with means to readily verify the number of revolutions of the drum, blades, or paddles.

Provide stationary and truck mixers capable of combining the ingredients of the concrete within the specified time or the number of revolutions specified into a thoroughly mixed and uniform mass and capable of discharging the concrete so that at least 5 of the 6 requirements of Tex-472-A are met.

As directed, to resolve issues of mix uniformity and mixer performance, perform concrete uniformity tests on mixers or agitators in accordance with Tex-472-A.

Perform the mixer or agitator uniformity test at the full rated capacity of the equipment and within the maximum mixing time or

421.4 to 421.4

maximum number of revolutions. Remove from service all equipment that fails the uniformity test.

Inspect and maintain mixers and agitators. Keep them reasonably free of concrete buildup, and repair or replace worn or damaged blades or fins.

Ensure all mixers have a plate affixed showing manufacturer's recommended operating speed and rated capacity for mixing and agitating.

- B. Hauling Equipment.** Provide hauling equipment capable of maintaining the mixed concrete in a thoroughly mixed and uniform mass and of discharging the concrete with a satisfactory degree of uniformity.

When using non-agitating equipment for transporting concrete, provide equipment with smooth, mortar-tight metal containers equipped with gates that prevent accidental discharge of the concrete.

- C. Testing Equipment.** Unless otherwise shown on the plans or specified, in accordance with the pertinent test procedure, furnish and maintain:

- test molds,
- curing facilities,
- maturity meters if used, and
- wheelbarrow or other container acceptable for the sampling of the concrete.

Provide strength-testing equipment in accordance with the Contract controlling test unless shown otherwise.

421.4. Construction.

- A. Classification and Mix Design.** Furnish mix designs using ACI 211, "Standard Practice for Selecting Proportions for Normal, Heavyweight, and Mass Concrete," or other approved procedures for the classes of concrete required in accordance with Table 5. Do not exceed the maximum water-to-cementitious-material ratio.

A higher-strength class of concrete with equal or lower water-to-cementitious-material ratio may be substituted for the specified class of concrete.

To account for production variability and ensure minimum compressive strength requirements are met, over-design the mix in accordance with Table 6.

- 1. Cementitious Materials.** Use cementitious materials from prequalified sources; otherwise, request sampling and testing for approval before use. Unless otherwise specified or approved, limit cementitious material content to no more than 700 lb. per cubic yard. When supplementary cementing materials are used, “cement” is defined as “cement plus supplementary cementing material.”

Use Type III cement only in precast concrete or when specified or permitted.

For monolithic placements, use cement of the same type and from the same source.

When sulfate-resistant concrete is required, use mix design options 1, 2, 3, or 4 given in Section 421.4.A.6, “Mix Design Options,” using Type I/II, II, V, IP, or IS cement. Do not use Class C fly ash in sulfate-resistant concrete.

Do not use supplementary cementing materials when white hydraulic cement is specified.

Table 5
Concrete Classes

Class of Concrete	Design Strength, Min. 28-day f'_c (psi)	Maximum W/C Ratio ¹	Coarse Aggregate Grades ^{2,3}	General Usage ⁴
A	3,000	0.60	1-4, 8	Inlets, manholes, curb, gutter, curb & gutter, conc. retards, sidewalks, driveways, backup walls, anchors
B	2,000	0.60	2-7	Riprap, small roadside signs, and anchors
C ⁵	3,600	0.45	1-6	Drilled shafts, bridge substructure, bridge railing, culverts except top slab of direct traffic culverts, headwalls, wing walls, approach slabs, concrete traffic barrier (cast-in-place)
D	1,500	0.60	2-7	Riprap
E	3,000	0.50	2-5	Seal concrete
F ⁵	Note 6	0.45	2-5	Railroad structures; occasionally for bridge piers, columns, or bents
H ⁵	Note 6	0.45	3-6	Prestressed concrete beams, boxes, piling, and concrete traffic barrier (precast)
S ⁵	4,000	0.45	2-5	Bridge slabs, top slabs of direct traffic culverts
P	See Item 360	0.45	2-3	Concrete pavement
DC ⁵	5,500	0.40	6	Dense conc. overlay
CO ⁵	4,600	0.40	6	Conc. overlay
LMC ⁵	4,000	0.40	6-8	Latex-modified concrete overlay
SS ⁵	Note 7	0.45	4-6	Slurry displacement shafts, underwater drilled shafts
K ⁵	Note 6	0.45	Note 6	Note 6
HES	Note 6	0.45	Note 6	Note 6

1. Maximum water-cement or water-cementitious ratio by weight.
2. Unless otherwise permitted, do not use Grade 1 coarse aggregate except in massive foundations with 4-in. minimum clear spacing between reinforcing steel bars. Do not use Grade 1 aggregate in drilled shafts.
3. Unless otherwise approved, use Grade 8 aggregate in extruded curbs.
4. For information only.
5. Structural concrete classes.
6. As shown on the plans or specified.
7. Cementitious material content shall be minimum 658 lb/cy of concrete.

Table 6
Over Design to Meet Compressive Strength Requirements¹

No. of Tests ^{2,3}	Standard Deviation, psi				
	300	400	500	600	700
15	470	620	850	1,120	1,390
20	430	580	760	1,010	1,260
30 or more	400	530	670	900	1,130

1. When designing the mix, add the tabulated amounts to the minimum design strength in Table 5.

2. Number of tests of a concrete mixture used to estimate the standard deviation of a concrete production facility. Test of another mix within 1,000 psi of the specified strength may be used.

3. If less than 15 prior tests are available, the overdesign should be 1,000 psi for specified strength less than 3,000 psi, 1,200 psi for specified strengths from 3,000 to 5,000 psi and 1,400 psi for specified strengths greater than 5,000 psi.

2. **Aggregates.** Limit the use of recycled crushed hydraulic cement concrete as a coarse or fine aggregate to Class A, B, D, E, and P concrete. Limit recycled crushed concrete fine aggregate to a maximum of 20% of the fine aggregate.

When white hydraulic cement is specified, use light-colored aggregates.

3. **Chemical Admixtures.** Use only preapproved concrete chemical admixtures from the list of prequalified concrete admixtures maintained by the Construction Division. Submit non-preapproved admixtures for testing to the Engineer for approval. Do not use high-range water-reducing admixtures (Type F or G) or accelerating admixtures (Type C or E) in bridge deck concrete.
4. **Air Entrainment.** Air-entrain all concrete except for Class B in accordance with Table 7 unless otherwise shown on the plans. Use moderate exposure values unless otherwise specified. If the air content is more than 1-1/2 percentage points below or 3 percentage points above the required air, the load of concrete will be rejected. If the air content is more than 1-1/2 but less than 3 percentage points above the required air, the concrete may be accepted based on strength tests.

Table 7
Air Entrainment

Nominal Maximum Aggregate Size, in.	% Air ¹	
	Moderate Exposure	Severe Exposure
3/8 (Grades 7 & 8)	6	7-1/2
1/2 (Grade 6)	5-1/2	7
3/4 (Grade 5)	5	6
1 (Grade 4)	4-1/2	6
1-1/2 (Grades 2 & 3)	4-1/2	5-1/2
2 (Grade 1)	4	5

1. For specified concrete strengths above 5,000 psi a reduction of 1 percentage point is permitted.

- 5. Slump.** Unless otherwise specified, provide concrete slump in accordance with Table 8 using the lowest slump possible that can be placed and finished efficiently without segregation or honeycombing.

Concrete that exceeds the maximum acceptable placement slump at time of delivery will be rejected.

When approved, the slump of a given concrete mix may be increased above the values shown in Table 8 using chemical admixtures, provided that the admixture-treated concrete has the same or lower water-cement or water-cementitious-material ratio and does not exhibit segregation or excessive bleeding. Request approval for the mix design sufficiently in advance for proper evaluation by the Engineer.

**Table 8
Slump Requirements**

Concrete Designation	Recommended Design and Placement Slump, in.	Maximum Acceptable Placement Slump, in.
Drilled shafts	See Item 416	See Item 416
Thin walled section (9 in. or less)	4	6-1/2
Approach slabs, concrete overlays, caps, columns, piers, wall sections (over 9 in.)	3	5
Bridge slabs	4	5-1/2
Prestressed concrete members ¹	4	6-1/2
Concrete traffic barrier, concrete bridge railing	4	6-1/2
Dense concrete overlay	3/4	2
Latex-modified conc. for bridge deck overlays	3	7-1/2
Concrete placed underwater	6	8-1/2
Concrete pavement (slip-formed)	1-1/2	3
Concrete pavement (formed)	4	6-1/2
Riprap, curb, gutter, slip-formed, and extruded concrete	As approved	As approved

1. If a high-range water reducer (HRWR) is used, maximum acceptable placement slump will be 9 in.

- 6. Mix Design Options.** For structural concrete identified in Table 5 and any other class of concrete designed using more than 520 lb. of cementitious material per cubic yard, use one of the mix design Options 1–8 shown below.

For concrete classes not identified as structural concrete and designed using less than 520 lb. of cementitious material per cubic yard, use one of the mix design Options 1–8 shown in Table 5, except that Class C fly ash may be used instead of Class F fly ash for Options 1, 3, and 4 unless sulfate-resistant concrete is required.

- a. Option 1.** Replace 20 to 35% of the cement with Class F fly ash.
- b. Option 2.** Replace 35 to 50% of the cement with GGBFS.
- c. Option 3.** Replace 35 to 50% of the cement with a combination of Class F fly ash, GGBFS, or silica fume.

421.4 to 421.4

However, no more than 35% may be fly ash, and no more than 10% may be silica fume.

- d. **Option 4.** Use Type IP or Type IS cement. (Up to 10% of a Type IP or Type IS cement may be replaced with Class F fly ash, GGBFS, or silica fume.)
- e. **Option 5.** Replace 35 to 50% of the cement with a combination of Class C fly ash and at least 6% of silica fume, UFFA, or metakaolin. However, no more than 35% may be Class C fly ash, and no more than 10% may be silica fume.
- f. **Option 6.** Use a lithium nitrate admixture at a minimum dosage of 0.55 gal. of 30% lithium nitrate solution per pound of alkalis present in the hydraulic cement.
- g. **Option 7.** When using hydraulic cement only, ensure that the total alkali contribution from the cement in the concrete does not exceed 4.00 lb. per cubic yard. of concrete when calculated as follows:

$$\text{lb. alkali per cu. yd.} = \frac{(\text{lb. cement per cu. yd.}) \times (\% \text{ Na}_2\text{O equivalent in cement})}{100}$$

In the above calculation, use the maximum cement alkali content reported on the cement mill certificate.

- h. **Option 8.** For any deviations from Options 1–7, perform the following:
 - Test both coarse and fine aggregate separately in accordance with ASTM C 1260, using 440 g of the proposed cementitious material in the same proportions of hydraulic cement to supplementary cementing material to be used in the mix.
 - Before use of the mix, provide the certified test report signed and sealed by a licensed professional engineer demonstrating that the ASTM C 1260 test result for each aggregate does not exceed 0.10% expansion.
- B. Trial Batches.** Perform all preliminary trial batches and testing necessary to substantiate the proposed mix designs, and provide documentation including mix design, material proportions, and test results substantiating that the mix design conforms to specification requirements.

Make all final trial batches using the proposed ingredients in a mixer that is representative of the mixers to be used on the job. Make the batch size at least 50% of the mixer's rated capacity. Perform fresh concrete tests for air and slump, and make, cure, and test strength specimens for compliance with specification requirements. Test at least 3 sets of design strength specimens with 2 specimens per set in accordance with Tex-418-A or Tex-448-A for each test age. Before placing, provide the Engineer the option of witnessing final trial batches, including the testing of the concrete. If not provided this option, the Engineer may require additional trial batches, including testing, before the concrete is placed.

Establish 7-day compressive strength target values using the following formula for each concrete mix to be used:

$$\text{Target value} = \text{Minimum design strength} \times \frac{7\text{-day avg. trial batch strength}}{28\text{-day avg. trial batch strength}}$$

When there are changes in aggregates or in type, brand, or source of cement, SCM, or chemical admixtures, reevaluate the mix as a new mix design. A change in vendor does not necessarily constitute a change in materials or source. When only the brand or source of cement is changed and there is a prior record of satisfactory performance of the cement with the ingredients, new trial batches may be waived by the Engineer.

When the maturity method is specified or permitted, establish the strength–maturity relationship in accordance with Tex-426-A. When using the maturity method any changes in any of the ingredients, including changes in proportions, will require the development of a new strength–maturity relationship for the mix.

C. Storage of Materials.

1. **Cement, Supplementary Cementing Materials, and Mineral Filler.** Store all cement, supplementary cementing materials, and mineral filler in weatherproof enclosures that will protect them from dampness or absorption of moisture.

When permitted, small quantities of sacked cement may be stored in the open, on a raised platform, and under waterproof covering for up to 48 hours.

2. **Aggregates.** Handle and store concrete aggregates in a manner that prevents contamination with foreign materials. If the aggregates are stored on the ground, clear the sites for the stockpiles of all

421.4 to 421.4

vegetation, level the sites, and do not use the bottom 6-in. layer of aggregate without cleaning the aggregate before use.

When conditions require the use of 2 or more grades of coarse aggregates, maintain separate stockpiles and prevent intermixing. Where space is limited, separate the stockpiles using physical barriers. Store aggregates from different sources in different stockpiles unless the Engineer authorizes pre-blending of the aggregates. Minimize segregation in stockpiles. Remix and test stockpiles when segregation is apparent.

Sprinkle stockpiles to control moisture and temperature as necessary. Maintain reasonably uniform moisture content in aggregate stockpiles.

3. **Admixtures.** Store admixtures in accordance with manufacturer's recommendations and prevent admixtures from freezing.

D. Measurement of Materials. Except for volumetric mixers, measure concrete materials by weight. Measure mixing water, consisting of water added to the batch, ice added to the batch, water occurring as surface moisture on the aggregates, and water introduced in the form of admixtures, by volume or weight. Measure ice by weight. Measure cement and supplementary cementing materials in a weigh hopper and on a separate scale from those used for other materials. Measure the cement first when measuring the cumulative weight. Measure concrete chemical admixtures in powdered form by weight. Measure concrete chemical admixtures in liquid form by weight or volume. Measure batch materials within the tolerances of Table 9.

Table 9
Measurement Tolerances – Non-Volumetric Mixers

Material	Tolerance (%)
Cement, wt.	±1
Mineral admixture, wt.	±1
Cement + SCM (cumulative weighing), wt.	±1
Water, wt. or volume	±3
Fine aggregate, wt.	±2
Coarse aggregate, wt.	±2
Fine + coarse aggregate (cumulative weighing), wt.	±1
Chemical admixtures, wt. or volume	±3

When measuring cementitious materials at less than 30% of scale capacity, ensure that the quantity measured is accurate to not less than

the required amount and not more than 4% in excess. When measuring aggregates in a cumulative weigh batcher at less than 30% of the scale capacity, ensure that the cumulative quantity is measured accurate to $\pm 0.3\%$ of scale capacity or $\pm 3\%$ of the required cumulative weight, whichever is less.

For volumetric mixers, base tolerances on volume–weight relationship established by calibration, and measure the various ingredients within the tolerances of Table 10.

Correct batch weight measurements for moisture.

When approved, under special circumstances, measure cement in bags of standard weight. Weighing of sacked cement is not required. Do not use fractional bags except for small hand-mixed batches of approximately 5 cu. ft. or less and when an approved method of volumetric or weight measurement is used.

Table 10
Measurement Tolerances – Volumetric Mixers

Material	Tolerance
Cement, wt. %	0 to +4
SCM, wt. %	0 to +4
Fine aggregate, wt. %	± 2
Coarse aggregate, wt. %	± 2
Admixtures, wt. or volume %	± 3
Water, wt. or volume %	± 1

E. Mixing and Delivering Concrete. Mix and deliver concrete by means of one of the following operations:

- central-mixed,
- shrink-mixed,
- truck-mixed,
- volumetric mixer-mixed, or
- hand-mixed.

Operate mixers and agitators within the limits of the rated capacity and speed of rotation for mixing and agitation as designated by the manufacturer of the equipment.

For shrink-mixed and truck-mixed concrete, when there is a reason to suspect the uniformity of concrete delivered using a truck mixer or truck agitator, conduct slump tests of 2 individual samples taken after discharging approximately 15% and 85% of the load as a quick check of the probable degree of uniformity. Take the 2 samples within an

421.4 to 421.4

elapsed time of at most 15 min. If the slumps of the 2 samples differ by more than the values shown in Table 11, investigate the causes and take corrective actions including adjusting the batching sequence at the plant and the mixing time and number of revolutions. Delivery vehicles that fail to meet the mixing uniformity requirements must not be used until the condition is corrected.

Table 11
Slump Tolerance¹

Average Slump	Slump Tolerance²
4 in. or less	1.0 in.
4 to 6 in.	1.5 in.

1. Do not apply these tolerances to the required slumps in Table 8.

2. Maximum permissible difference in results of test of samples from 2 locations in the concrete batch.

Re-tempering or adding concrete chemical admixtures is only permitted at the job site when concrete is delivered in a truck mixer. Do not add water after the introduction of mixing water at the batch plant except on arrival at the job site, with approval, to adjust the slump of the concrete. When this water is added, do not exceed the mix design water–cementitious-material ratio. Turn the drum or blades at least 30 additional revolutions at mixing speed to ensure thorough and uniform mixing of the concrete. Do not add water or chemical admixtures to the batch after any concrete has been discharged.

Maintain concrete delivery and placement rates sufficient to prevent cold joints.

Before unloading, furnish the delivery ticket for the batch of concrete containing the information required on Department Form 596, “Concrete Batch Ticket.”

When the concrete contains silica fume, adjust mixing times and batching operations as necessary to ensure the material is completely and uniformly dispersed in the mix. The dispersion of the silica fume within the mix will be verified by the Construction Division, Materials and Pavements Section, using cylinders made from trial batches. If uniform dispersion is not achieved, make necessary changes to the batching operations until uniform and complete dispersion of the silica fume is achieved.

- 1. Central-Mixed Concrete.** Provide concrete that is mixed completely in a stationary mixer. Mix concrete for a period of 1 min. for 1 cu. yd. and 15 sec. for each additional cu. yd. of rated

capacity of the mixer unless mixer performance test data demonstrate that shorter mixing times can be used to obtain a uniform mix in accordance with Tex-472-A. Count the mixing time from the time all the solid materials are in the drum. Charge the mixer so that some water will enter before the cement and aggregate. Ensure that all water is in the drum by the end of the first 1/4 of the specified mixing time. Adjust the mixing time if necessary to achieve a uniform mix. Concrete mixed completely in a stationary mixer must be delivered to the project in a truck mixer, truck agitator, or non-agitating delivery vehicle. When a truck mixer or truck agitator is used for transporting concrete, use the manufacturer's designated agitating speed for any turning during transportation. Non-agitating delivery vehicles must be clean and free of built-up concrete with adequate means to control concrete discharge. Deliver the concrete to the project in a thoroughly mixed and uniform mass, and discharge the concrete with a satisfactory degree of uniformity. Resolve questions regarding the uniformity of the concrete by testing when directed by the Engineer in accordance with Tex-472-A.

2. **Shrink-Mixed Concrete.** Provide concrete that is first partially mixed in a stationary mixer and then mixed completely in a truck mixer. Partially mix for the minimum time required to intermingle the ingredients in the stationary mixer, and then transfer to a truck mixer and mix the concrete at the manufacturer's designated mixing speed for an adequate amount of time to produce thoroughly mixed concrete. Deliver the concrete to the project in a thoroughly mixed and uniform mass, and discharge the concrete with a satisfactory degree of uniformity.
3. **Truck-Mixed Concrete.** Mix the concrete in a truck mixer from 70 to 100 revolutions at the mixing speed designated by the manufacturer to produce a uniform concrete mix. Deliver the concrete to the project in a thoroughly mixed and uniform mass and discharge the concrete with a satisfactory degree of uniformity. Additional mixing at the job site at the mixing speed designated by the manufacturer is allowed as long as concrete is discharged before the drum has revolved a total of 300 revolutions after the introduction of the mixing water to the cement and the aggregates.
4. **Volumetric Mixer-Mixed Concrete.** Unless otherwise specified or permitted, perform all mixing operations in accordance with manufacturer's recommended procedures. Provide an accurate method of measuring all ingredients by volume, and calibrate

421.4 to 421.4

equipment to assure correct measurement of materials within the specified tolerances.

5. **Hand-Mixed Concrete.** When permitted, for small placements of less than 2 cu. yd., mix up to a 2-sack batch of concrete by hand methods or in a small motor-driven mixer. For such placements, proportion the mix by volume or weight.
- F. **Placing, Finishing, and Curing Concrete.** Place, finish, and cure concrete in accordance with the pertinent Items.
- G. **Sampling and Testing of Concrete.** Unless otherwise specified, all fresh and hardened concrete is subject to testing as follows:
 1. **Sampling Fresh Concrete.** Provide all material to be tested. Fresh concrete will be sampled for testing at the discharge end if using belt conveyors or pumps. When it is impractical to sample at the discharge end, a sample will be taken at the time of discharge from the delivery equipment and correlation testing will be performed and documented to ensure specification requirements are met at the discharge end.
 2. **Testing of Fresh Concrete.**
 - a. **Air Content.** Tex-414-A or Tex-416-A.
 - b. **Slump.** Tex-415-A.
 - c. **Temperature.** Tex-422-A.
 - d. **Making and Curing Strength Specimens.** Tex-447-A.
 3. **Testing of Hardened Concrete.** Only compressive strength testing will be used unless otherwise specified or shown on the plans.
 - a. **Compressive Strength.** Tex-418-A.
 - b. **Flexural Strength.** Tex-448-A.
 - c. **Maturity.** Tex-426-a.
 4. **Certification of Testing Personnel.** Contractor personnel performing testing must be either ACI-certified or qualified by a Department-recognized equivalent written and performance testing program for the tests being performed. Personnel performing these tests are subject to Department approval. Use of a commercial laboratory is permitted. All personnel performing testing using the maturity method must be qualified by a training program recognized by the Department before using this method on the job.

- 5. Adequacy and Acceptance of Concrete.** The Engineer will sample and test the fresh and hardened concrete for acceptance. The test results will be reported to the Contractor and the concrete supplier. For any concrete that fails to meet the required strengths as outlined below, investigate the quality of the materials, the concrete production operations, and other possible problem areas to determine the cause. Take necessary actions to correct the problem including redesign of the concrete mix. The Engineer may suspend all concrete operations under the pertinent Items if the Contractor is unable to identify, document, and correct the cause of the low strengths in a timely manner. Resume concrete operations only after obtaining approval for any proposed corrective actions.
- a. Structural Concrete.** For concrete classes identified as structural concrete in Table 5, the Engineer will make and test 7-day and 28-day specimens. Acceptance will be based on the design strength given in Table 5.
- The Engineer will evaluate the adequacy of the concrete by comparing 7-day test results to the target value established in accordance with Section 421.4.B, "Trial Batches."
- b. All Other Concrete.** For concrete classes not identified as structural concrete in Table 5, the Engineer will make and test 7-day specimens. The Engineer will base acceptance on the 7-day target value established in accordance with Section 421.4.B, "Trial Batches."
- 6. Test Sample Handling.** Unless otherwise shown on the plans or directed, remove forms and deliver department test specimens to curing facilities, in accordance with pertinent test procedures. Clean and prepare forms for reuse.

421.5. Measurement and Payment. The work performed, materials furnished, equipment, labor, tools, and incidentals will not be measured or paid for directly but will be subsidiary to pertinent Items.

ITEM 422

REINFORCED CONCRETE SLAB

422.1. Description. Form and construct reinforced concrete bridge slab.

422.2. Materials. Furnish materials in accordance with:

- Item 420, "Concrete Structures"

422.3 to 422.4

- Item 421, “Hydraulic Cement Concrete”
- Item 426, “Prestressing”
- Item 440, “Reinforcing Steel.”

Use Class S for all cast-in-place concrete unless otherwise shown on the plans.

422.3. Construction.

- A. Cast-in-Place Slab.** Use conventional forms, permanent metal deck forms, or prestressed concrete panels. Use permanent metal deck forms or conventional forms for thickened slabs, diaphragms, or other regions as shown on the plans where prestressed concrete panels are not used. Construct the slab as shown on the plans and in accordance with the pertinent requirements of:
- Item 420, “Concrete Structures”
 - Item 424, “Precast Concrete Structures (Fabrication)”
 - Item 426, “Prestressing”
 - Item 440, “Reinforcing Steel.”
- B. Extending Existing Slabs.** Extend existing slabs in accordance with Item 430, “Extending Concrete Structures.”
- C. Prestressed Concrete Panels.** Profile each beam to determine the actual camber or sag of the beams before placing panels. Adjust the profile grade line, panel elevation, and bearing seat elevations as needed to obtain the required cover over the slab reinforcement and the required slab thickness. When a profile grade line adjustment is necessary, make adjustments over suitable increments, depending on span lengths, so that the revised grade line will produce a uniform profile and good riding qualities. Obtain approval for the grade adjustments prior to placement. Consider actual beam camber in adjacent spans or slab placements when adjusting the grade line. Place the top portion of abutment backwalls and wings after adjustment to the profile grade line.

422.4. Measurement. Reinforced concrete slab placed under this Item will be measured by the square foot of slab surface area using the nominal dimensions and configuration shown on the plans. Transverse measurement will be made from outer edge of slab to outer edge of slab (including raised median and sidewalk sections). Longitudinal measurement will be made between ends of units or spans. Diaphragms, haunch concrete, reinforcement, and optional steel diaphragms will be considered as a portion of the slab.

This is a plans quantity measurement Item. The quantity to be paid is the quantity shown in the proposal unless modified by Article 9.2, “Plans Quantity Measurement.” Additional measurements or calculations will be made if adjustment of quantities is required.

The quantities of concrete and reinforcing steel shown on the plans are based on a conventionally formed slab. These quantities include amounts for concrete diaphragms, brackets and other required attachments, and haunch concrete when required, based on the profile grade, theoretical camber, and dead load deflection of the beams. No additional measurement will be made for concrete or reinforcing steel due to a variation in camber of the beams from theoretical camber, or for additional quantities required by optional methods of forming.

422.5. Payment. The work performed and materials furnished in accordance with this Item and measured as provided under “Measurement” will be paid for at the unit price bid for “Reinforced Concrete Slab” and “Reinforced Concrete Slab (Extend Slab).” This price is full compensation for furnishing, hauling, mixing, placing, curing, and finishing concrete; furnishing and placing reinforcing steel; grouting and pointing; furnishing and placing drains and expansion joint material (except where specifically furnished under another Item); furnishing and placing metal flashing strips; forms (removable and permanent) and falsework; prestressed concrete panels; furnishing and placing concrete and reinforcement for raised medians, sidewalks, sign mounts, luminaire brackets, and other concrete appurtenances; removing designated portions of existing slab; cleaning, bending, and cutting exposed existing reinforcing steel; welding reinforcing steel; doweling; cleaning and preparing concrete surfaces; and equipment, labor, tools, and incidentals.

Structural steel, anchor bolts, armor joints, sealed expansion joints, rail (including the concrete parapet portion), and concrete median barrier will be measured and paid for in accordance with pertinent bid items.

ITEM 423 RETAINING WALLS

423.1. Description. Furnish, construct, and install retaining walls.

423.2. Materials.

- A. General.** Furnish materials in accordance with the following:
- Item 420, “Concrete Structures”

423.2 to 423.2

- Item 421, “Hydraulic Cement Concrete”
- Item 440, “Reinforcing Steel”
- Item 445, “Galvanizing”
- Item 458, “Waterproofing Membranes for Structures”
- Item 556, “Pipe Underdrains.”

Unless otherwise shown on the plans, use concrete for retaining walls that conforms to the requirements of Table 1.

Table 1
Concrete for Retaining Walls

Application	Concrete
Cast-in-place, non-reinforced	Class A
Cast-in-place, reinforced	Class C
Precast	Class H, $f'_c = 4,000$ psi

Furnish concrete for machine-made concrete block units in accordance with ASTM C 90, Class 1, Type II, except that the minimum 28-day compressive strength must be 4,000 psi with maximum moisture absorption of 7%.

Provide Type 1 filter fabric in accordance with DMS-6200, “Filter Fabric.” Provide filter fabric rated as UV-resistant when used as part of the exposed facing for a temporary wall.

Joint fillers, pads, waterstops, and other incidental materials must be as shown on the plans or approved by the Engineer.

When the plans call for epoxy coating of steel earth reinforcements, epoxy coat all steel used in concrete panels and coping including connectors, dowels, stirrups, and reinforcing steel.

B. Fabrication.

1. **Cast-in-Place.** Meet Item 420, “Concrete Structures.”
2. **Formed Precast.** Meet Item 424, “Precast Concrete Structures (Fabrication).”
3. **Machine-Made Precast.** Furnish machine-made concrete block units in accordance with ASTM C 90, sampled and tested in accordance with ASTM C 140. Furnish units with molded dimensions within 1/8 in. of specified dimensions, except height must be within 1/16 in.

C. Backfill.

1. **Non-Select.** Furnish backfill meeting Item 132, “Embankment,” of the type specified in the plans. If no type is specified, provide material with a maximum plasticity index of 30 as determined by Tex-106-E.
2. **Select.** Select backfill is required in specific areas of permanent and temporary MSE and concrete block-type retaining walls. Provide select backfill that is free from organic or otherwise deleterious materials and that conforms to the gradation limits in Table 2 as determined by Tex-110-E.

Provide backfill that does not contain shale, caliche, or other soft, poor-durability coarse aggregate particles. Backfill appearing to contain such particles will be tested for soundness. Backfill with 5-cycle magnesium sulfate soundness of more than 30% when tested in accordance with Tex-411-A will be rejected.

Type A, B, and D particles larger than 1/4 in. must be angular or crushed. Rounded rock or gravel is not allowed.

Table 2
Select Backfill Gradation Limits

Type	Sieve Size	Percent Retained
A	3 in.	0
	1/2 in.	50–100
	No. 4	See Note
	No. 40	85–100
B	3 in.	0
	No. 4	See Note
	No. 40	40–100
	No. 200	85–100
C	3 in.	0
	No. 4	See Note
	No. 200	70–100
D	3 in.	0
	3/8 in.	85–100

Note: Use No. 4 sieve for determination of rock backfill as described in Section 423.C, “Backfill.”

When the backfill gradation results in 85% or more material retained on the No. 4 sieve, the backfill will be considered rock backfill. All Type D backfill is considered rock backfill.

Unless otherwise shown on the plans, furnish Type B backfill for permanent walls. Furnish Type C backfill for temporary walls. Furnish Type D backfill for areas of walls subject to inundation or below the 100-year flood elevation as noted in the plans.

When nonmetallic or epoxy-coated earth reinforcements are used, furnish backfill meeting the requirements of this Section but with a maximum particle size of 3/4 in.

3. **Drainage Aggregate.** Use drainage aggregate to fill the void within concrete block units and in the zone 1 ft. behind the units. Provide drainage aggregate that is free from organic or otherwise deleterious materials and that conforms to the gradation limits in Table 3 as determined by Tex-110-E.

**Table 3
Drainage Aggregate Gradation Limits**

Sieve Size	Percent Retained
1 in.	0
3/4 in.	25–50
1/2 in.	50–100
No. 4	75–100

4. **Cement-Stabilized Backfill.** Use cement-stabilized backfill when required or as approved. Stabilize Type C backfill with 5% hydraulic cement by dry weight of the backfill material. Use a stationary plant to thoroughly mix the backfill material, cement, and water. Place and compact the backfill within 2 hours of mixing. When cement-stabilized backfill is used, provide special drainage provisions as shown on the plans.
5. **Electrochemical.** Provide backfill meeting the following additional requirements for permanent retaining wall systems using galvanized metallic earth reinforcements:
 - The pH is between 5.5 and 10.0 as determined by Tex-128-E.
 - Resistivity is more than 3,000 ohm-cm as determined by Tex-129-E.
 - Material with resistivity between 1,500 and 3,000 ohm-cm may be used if the chloride content is less than 100 ppm and the sulfate content is less than 200 ppm as determined by Tex-620-J.

When cement-stabilized backfill is used, perform electrochemical testing on the raw, unstabilized backfill material.

- D. Earth Reinforcements.** Furnish earth reinforcements that meet the design requirements. For permanent walls, galvanize or epoxy coat all steel elements in contact with soil. Epoxy coat in accordance with Item 440, "Reinforcing Steel," except provide a minimum 18-mil coating thickness. Epoxy coat the reinforcing only when shown in the plans or as approved. When using nonmetallic or epoxy coated earth reinforcements, use connection hardware that is likewise nonmetallic or epoxy coated.

423.3. Construction.

- A. General.** Construct retaining walls in accordance with details shown on the plans, on the approved working drawings, and to the pertinent requirements of the following Items:

- Item 110, "Excavation"
- Item 132, "Embankment"
- Item 400, "Excavation and Backfill for Structures"
- Item 420, "Concrete Structures"
- Item 458, "Waterproofing Membranes for Structures"
- Item 556, "Pipe Underdrains."

Construct required piling or drilled shafts in accordance with the pertinent specification.

- B. Definitions.** This Item uses the following terms:

- Permanent Wall – A retaining wall with a design service life of 75 years. All walls are presumed to be permanent walls unless otherwise specified in the plans.
- Temporary Wall – A retaining wall so designated by description, with a design service life of 3 years.
- Mechanically Stabilized Earth (MSE) Wall – A wall consisting of a volume of select backfill with tensile earth reinforcement elements distributed throughout. Permanent MSE walls use a precast concrete panel as a facing element. Temporary MSE walls use welded wire fabric with filter fabric backing as a facing element.
- Concrete Block Wall – A retaining wall that uses machine-made, precast concrete block units as facing elements. The walls may use a volume of select fill with tensile earth reinforcements distributed throughout, or may use only the facing unit and unit fill weight for support.

423.3 to 423.3

- C. Options.** When optional design details are shown on the plans, the Contractor is required to use the same facing design within an area of continuous retaining walls.

When proposing the use of 2 or more systems, provide drawings for review indicating the proposed design arrangement.

- D. Working Drawings.** When proprietary wall systems are used, submit casting drawings, construction drawings, and design calculations bearing the seal of a licensed professional engineer for review and approval. For permanent walls, submit 7 sets of casting and construction drawings and 2 sets of design calculations. Upon completion of construction, submit 1 set of reproducible as-built drawings to the Engineer. For temporary walls, submit 5 sets of construction drawings, and 2 sets of design calculations.

1. Casting Drawings. Include all information necessary for casting wall elements, including railing and coping when prefabricated. Show shape and dimensions of panels; size, quantity, and details of the reinforcing steel; quantity, type, size, and details of connection and lifting hardware; and additional necessary details.

2. Construction Drawings. Include a numbered panel layout showing horizontal and vertical alignment of the walls as well as the existing and proposed groundlines. Include all information needed to erect the walls, including the proposed leveling pad elevations; the type and details of the soil reinforcing system (if applicable); the details and manufacturer of all pads, fillers, and filter fabric; the limits and dimensions of structural backfill; details necessary to incorporate coping, railing, inlets, drainage, and electrical conduit; and additional necessary details.

Leveling pad elevations may vary from the elevations shown on the plans. Unless a different minimum cover or a specified minimum leveling pad elevation is shown, provide at least 1 ft. of cover from the top of the leveling pad to finish grade.

3. Design Calculations. Include calculations covering the range of heights and loading conditions on the project. Calculations for both internal and external stability as described in the plans will be required. Include a summary of all design parameters used; material types, strength values, and assumed allowables; loads and loading combinations; and factor-of-safety parameters.

- E. Permanent MSE Walls.** Grade the foundation for the structure level for a width equal to or exceeding the length of the reinforcing system.

Compact the foundation with a smooth-wheel vibratory roller or other approved roller. Remove and replace unsuitable foundation soils.

Place drilled shafts and piling located within the MSE volume prior to construction of the wall. Place any required pipe underdrain before construction of the wall.

Place the concrete leveling pad as shown on the construction drawings. Provide a wood float finish, and wait a minimum of 24 hours before beginning panel erection. No curing or strength testing of the leveling pad concrete is required.

Shim the first row of panels as necessary to achieve correct alignment. Use plastic shims or other material that will not deteriorate. If the required shim height exceeds 1 in., remove and replace the leveling pad or provide a grout level-up as directed.

Place filter fabric behind the wall along the joint between the leveling pad and the panels. At leveling pad steps, grout areas where filter fabric spans more than 6 in.

After backfilling the first row of panels, place and compact fill material over the leveling pad to an elevation even with or above the surrounding ground. Do not allow water to accumulate and stand at the base of the wall.

Place filter fabric behind all wall joints and at the intersection of retaining walls with other structures, including riprap. Cover joints at least 6 in. on each side and use adhesive to hold the filter fabric in place.

Exercise care while lifting, setting, and aligning panels to prevent damage to the panels. Discontinue any operation that results in chipping, spalling, or cracking of panels. Remove and replace damaged panels, or repair as approved by the Engineer.

Provide external bracing for the initial row of panels. Use wooden wedges, clamps or other means necessary to maintain position and stability of panels during placement and compaction of backfill. Remove wooden wedges as soon as the panel or coping above the wedged element is erected and backfilled. Remove all wedges after completing the wall.

Review plumbness and position of each row of panels before placing the subsequent row. Remove and rebuild any portion of the wall that is out of tolerance. Modify panel batter and bracing, and backfill material, placement, and compaction methods as required to maintain wall tolerances.

423.3 to 423.3

Construct walls to a vertical and horizontal alignment tolerance of 3/4 in. when measured along a 10-ft. straightedge. Construct walls to an overall vertical tolerance (plumbness from top to bottom) of 1/2 in. per 10 ft. of wall height. Construct walls so that the maximum out-of-plane offset at any panel joint is less than 3/4 in.; no joint is open to the extent that the filter fabric is visible from the front of the wall; and no joint is closed to the extent that there is concrete-to-concrete contact.

Place backfill to closely follow the erection of each row of panels. Place the select and embankment backfill to the same elevation where possible, and operate the compaction equipment over the interface. Do not create a continuous, distinct, vertical joint between the select and embankment backfill. Do not complete the embankment prior to construction of the retaining wall.

When building a wall against existing ground, maintain the stability of the interface area between the existing ground and the select fill. Remove and recompact any material that loosens, caves, or fails.

Compact backfill to provide not less than 95% of density determined in accordance with Tex-114-E. Field density determination will be made in accordance with Tex-115-E.

Sprinkle backfill as required to ensure adequate uniformly distributed moisture in each lift prior to and during compaction. Place fill in lifts of 8 in. or less (loose measurement). Place fill in a manner that avoids segregation of the fill. Decrease the lift thickness if necessary to obtain the required compaction. Use hand-operated or walk-behind compaction equipment in the 3-ft. wide strip adjacent to the wall panels. Do not displace panels or distort or damage the reinforcement system during compaction. Modify backfill material, placement, and compaction methods as necessary to meet density requirements while maintaining wall tolerances.

Place rock backfill or material that the Engineer determines too coarse for density testing by the "Ordinary Compaction" method of Item 132, "Embankment."

At each earth reinforcement level, place and compact the backfill to the reinforcement level before placing the reinforcement. Place earth reinforcements perpendicular to the face of the wall. Remove slack in connections prior to placing backfill. For systems using nonmetallic earth reinforcements, pretension each layer of reinforcement to remove slack before placing backfill. Use devices capable of mechanically applying and holding the required force. Do not operate tracked equipment directly on any reinforcement.

When rock backfill is used, cover the rock backfill with filter fabric before placing the 2 ft. of backfill immediately below the pavement structure or top of wall. Overlap the fabric at least 18 in. at splices, and extend it past the edge of the rock backfill at least 18 in. Above the filter fabric, use backfill that contains sufficient fines to fill the voids in a compacted state. Place a horizontal layer of filter fabric as noted above when transitioning from rock backfill to finer grained backfill anywhere within the wall volume.

Prevent surface water or rainwater from damaging the retaining walls during construction. Shape the backfill to prevent water from ponding or flowing on the backfill or against the wall face. Remove and replace any portion of the retaining wall damaged or moved out of tolerance by erosion, sloughing, or saturation of the retaining wall or embankment backfill.

- F. Temporary MSE Walls.** Provide a facing system rigid enough to maintain a smooth and straight wall face both during and after construction.

Grade and compact the foundation for the structure as described in Section 423.3.E, "Permanent MSE Walls."

Place earth reinforcement and facing system in accordance with the approved working drawings. Backfill the 2-ft. zone immediately behind the facing with clean coarse rock meeting the requirements of Coarse Aggregate Grade 1, 2, or 3 of Item 421, "Hydraulic Cement Concrete," or of Type D backfill as described in Section 423.2.C.2, "Select." Cement-stabilized backfill as described in Section 423.2.C.4, "Cement-Stabilized Backfill," may be used in place of the coarse rock.

Place and compact backfill in accordance with the requirements of Section 423.3.E.

Construct walls to a vertical and horizontal alignment tolerance of 3 in. when measured along a 10 ft. straight edge. Construct walls to an overall vertical tolerance (plumbness from top to bottom) of 2 in. per 10 ft. of wall height. Place adjacent facing elements so that the maximum out-of-plane offset at any facing element joint is less than 1 in. Place facing elements and filter fabric with no gaps in the facing or fabric.

Prevent surface water or rainwater from damaging the retaining walls during and after construction. Place temporary berms or curbs, shape the backfill, or use other approved methods to prevent water from flowing against or over the wall face. Remove and replace any portion

423.4 to 423.4

of the wall damaged or moved out of tolerance by erosion, sloughing, or saturation of the retaining wall or embankment backfill.

- G. Concrete Block Retaining Walls.** The concrete block units may be sampled and tested by the Engineer prior to shipment or upon delivery to the construction site. Display for approval samples of block units indicating the color, texture, and finish. Store, transport, and handle all block units carefully to prevent cracking or damage.

Grade and compact the foundation for the structure, and place the leveling pad as described in Section 423.3.E, “Permanent MSE Walls.”

Place the concrete block facing units in accordance with the approved working drawings. Fill the voids within the units and fill the 1-ft. zone immediately behind the facing with drainage aggregate as described in Section 423.2.C.3, “Drainage Aggregate.” Systems tested without unit fill may omit the fill as indicated on the approved drawings. Systems with approved filter fabric details may omit the drainage aggregate in the 1-ft. zone immediately behind the facing.

For walls using earth reinforcements, place reinforcements and backfill in accordance with the requirements of Section 423.3.E. Pay particular attention to the connection details of the earth reinforcements to the concrete block units.

Construct walls to a vertical and horizontal alignment tolerance of 1-1/2 in. when measured along a 10-ft. straightedge. Construct walls to an overall vertical tolerance (deviation from the vertical or battered control line, top to bottom) of 1 in. per 10 ft. of wall height. Place adjacent facing elements so that the maximum out-of-plane offset at any facing element joint is less than 1 in. Place facing elements with maximum 1/4-in. gaps between block units.

Prevent surface water or rainwater from damaging the retaining walls during construction. Shape the backfill to prevent water from ponding or flowing on the backfill or against the wall face. Remove and replace all portions of the retaining wall damaged or moved out of tolerance by erosion, sloughing, or saturation of the retaining wall or embankment backfill.

423.4. Measurement. This Item will be measured by the square foot of the front surface area of the wall. Unless otherwise shown on the plans, the area will be measured from 1 ft. below finished grade of the ground line on the face of the exterior wall to the top of the wall including any coping required (not including railing).

This is a plans quantity measurement Item. The quantity to be paid is the quantity shown in the proposal unless modified by Article 9.2, “Plans Quantity Measurement.” Additional measurements or calculations will be made if adjustments of quantities are required.

423.5. Payment. The work performed and materials furnished in accordance with this Item and measured as provided under “Measurement” will be paid for at the unit price bid for “Retaining Walls” of the type or special surface finish specified. This price is full compensation for excavation in back of retaining walls and for footings; furnishing and placing footings, leveling pads, copings, and traffic railing foundations; furnishing, placing, and compacting backfill (except in embankment areas), including cement for stabilization; furnishing and placing concrete, reinforcing steel, waterproofing material, filter material and drain pipe, joint material, water stop, and filter fabric when required; fabricating, curing, and finishing all panels; furnishing and placing earth reinforcement, anchorage systems, and fasteners; wall erection; and equipment, labor, tools, and incidentals.

Retaining wall backfill areas that are also in embankment areas will be considered part of the quantities measured and paid for under Item 132, “Embankment.”

When drilled shafts are required, they will be measured and paid for as specified in Item 416, “Drilled Shaft Foundations.” When piling is required, it will be measured and paid for as specified in the plans for piling of the appropriate type.

ITEM 424

PRECAST CONCRETE STRUCTURES (FABRICATION)

424.1. Description. Fabricate precast prestressed and precast nonstressed concrete members. This Item, in conjunction with DMS-7300, “Precast Concrete Fabrication Plants,” applies to both multi-project and project-specific fabrication plants. For this Item, the following definitions apply:

- **Prestressed Members.** Precast concrete members fabricated by the process of pretensioning or post-tensioning or a combination of both methods.
- **Nonstressed Members.** Precast concrete members that have not been pretensioned or post-tensioned.

424.2 to 424.3

- **Multi-Project Fabrication Plant.** A facility at an offsite location that fabricates precast prestressed or precast nonstressed members for more than one Contract.
- **Project-Specific Fabrication Plant.** A temporary facility at or near the project location that fabricates precast prestressed or precast nonstressed members for only one Contract. This definition may be applied to temporary facilities that fabricate for multiple Contracts, if approved.
- **Major Prestressed Members.** Includes I-beams, bulb-tee beams, U-beams, and box beams (voided).
- **Minor Prestressed Members.** Includes all other prestressed members not listed as major prestressed members.
- **Temperature Probe.** Thermocouple for measuring concrete temperature or air temperature.
- **Temperature Recording Device.** Data logger for recording temperatures from the temperature probes.

424.2. Equipment.

- A. Field Office and Inspection Laboratory.** For multi-project and project-specific fabrication plants, provide a field office and inspection laboratory in accordance with DMS-7300, "Precast Concrete Fabrication Plants."
- B. Furnishings and Laboratory Equipment.** For multi-project and project-specific fabrication plants, provide furnishings and laboratory equipment in accordance with DMS-7300, "Precast Concrete Fabrication Plants."
- C. Plant Facilities.** For multi-project and project-specific fabrication plants that produce prestressed members, provide plant facilities in accordance with DMS-7300, "Precast Concrete Fabrication Plants."

424.3. Construction.

A. General Requirements.

1. Shop Drawings.

- a. Prestressed Members.** When optional designs are permitted by the plans, submit the proposed designs on forms furnished by the Department. Obtain approval of these designs before casting. Approval of optional designs does not relieve the Contractor from the responsibility of furnishing a satisfactory completed structure.

Unless otherwise shown on the plans or in other Items, furnish shop drawings for prestressed members. Prepare clear and legible shop drawings on 11 × 17 in. sheets. At the left end, provide a 1-in. margin, with the other margins 1/2-in. wide. Provide a title block on each sheet in the lower right corner with the following information:

- sheet index data shown on lower right corner of the project plans,
- sheet numbering for shop drawings,
- name of structure or stream,
- name of fabricator, and
- name of Contractor.

Submit 7 complete sets of shop drawings to the Engineer.

Submit 1 additional copy of each sheet if the owner is a non-Department entity such as a railroad or a municipal or turnpike authority, and another copy if the designer is a private consultant. The Engineer may require additional sets. Provide submittals for precast post-tensioned members in accordance with Section 426.4.A, “Required Submittals.”

- b. Nonstressed Members.** Furnish shop drawings for nonstressed members when required by the plans or pertinent Items.

2. Plant Approval.

- a. Plant Submittals.** Provide submittals in accordance with DMS-7300, “Precast Concrete Fabrication Plants,” for each particular plant operation. This requirement does not apply to project-specific nonstressed member fabrication plants.
- b. Plant Audits.** Multi-project and project-specific fabrication plants that produce major prestressed members must pass initial and periodic Department-directed plant audits in accordance with DMS-7300, “Precast Concrete Fabrication Plants.”

- 3. Notice of Beginning Work.** Give adequate notice before beginning work as specified in Table 1.

Table 1
Notice of Beginning Work

Plant Location	Notice Required
In Texas	7 days
In the contiguous United States	21 days
Outside the contiguous United States	60 days

Perform no Department work in the plant before the Engineer authorizes fabrication. When fabrication is performed outside of the contiguous 48 states, the additional cost of inspection will be in accordance with Article 6.4, "Sampling, Testing, and Inspection."

4. **Personnel Qualifications.** Provide qualified personnel in accordance with DMS-7300, "Precast Concrete Fabrication Plants," for each particular plant operation.
 5. **Quality Responsibilities.** The quality responsibilities for the Contractor for each particular plant operation will be in accordance with DMS-7300, "Precast Concrete Fabrication Plants."
- B. Fabrication.** Prepare a casting schedule on Department-approved forms per DMS-7300, "Precast Concrete Fabrication Plants," and submit it daily to the Department before fabrication. This requirement does not apply to project-specific minor prestressed member or project-specific nonstressed member fabrication plants.
1. **Forms.** Design forms to prevent damage to the concrete from restraint as the concrete shrinks, from form expansion and contraction from thermal changes, from stripping operations, and from dimensional changes due to pretensioning. Forms, regardless of material, must conform to the profiles, dimensions, and tolerances of the finished product as specified on the plans and in this Item. Maintain forms free from dents, grease, or other foreign materials that may affect the appearance of the member, and clean forms thoroughly before each casting operation and immediately before applying a form-release agent.
 - a. **External Forms.** Construct side and bottom forms of steel unless otherwise approved or noted on the plans. Wood forms, when permitted, must meet the requirements of Section 420.4.D, "Forms." End headers may be of other material as approved.

Construct forms with sufficient thickness, external bracing and stiffeners, and anchorage to withstand the forces generated during concrete placement and consolidation. Do not stabilize

forms with bracing and holding devices that will remain in the finished member.

Provide corners with a chamfer or radius where shown on the plans.

Maintain forms sufficiently mortar-tight to prevent damage that requires repair to the finished product. Where sections of forms will be joined, an offset of 1/16 in. for flat surfaces and 1/8 in. for corners and bends is permitted. Do not allow vertical or horizontal gaps or offsets to exceed 1/4 in. between adjacent sections of built-up end headers.

Check the grade and alignment of forms each time they are set, and maintain them during placement of concrete.

Apply a form-release agent, in accordance with the manufacturer's recommendations, to the facing of forms before placing concrete. Use a form-release agent that facilitates form removal and does not affect any required coating, painting, or color-staining operations. Do not use materials that appreciably stain or react with the concrete. Remove excess form-release agent from the form surface before casting, and ensure that it does not contaminate strands, reinforcing steel, and embedments. Use a clear form-release agent of the same brand throughout the casting of retaining wall panels per structure, unless it can be shown that a different form-release agent does not change the appearance of the concrete.

Construct the forms to facilitate removal of members without damage to the concrete.

Construct and maintain the soffit (liner) to provide a maximum 1/4-in. variation from the theoretical plane, and do not allow the soffit to vary more than 1/4 in. between any 2 points in any 50-ft. length.

At the Contractor's option, construct side forms for prestressed bridge deck panels with a 1/8-in. draft for ease of product removal.

- b. Internal Forms.** Use solid expanded polystyrene conforming to ASTM C 578 Type I for forming internal voids. The form material must be inert, non-biodegradable, non-absorptive, and strong enough to maintain sufficient rigidity to withstand the forces generated during concrete placement and consolidation

without damage. Other materials for forming internal voids may be used when approved. Provide certification of conformance for void forms. The Engineer may require samples to be submitted when needed.

Anchor internal void forms to prevent movement or misalignment while placing concrete. Provide hold-down devices for all types of void forms at 30-in. maximum spacing unless otherwise approved. Do not use internal hold-down or lateral bracing devices that will remain in the finished member unless approved. Provide enough bearing area on the void form to prevent penetration of hold-down devices into the void form. Splice void form sections to prevent separation or misalignment during concrete placement and consolidation operations.

During casting, verify and document void form placement at 10-ft. maximum spacing using an approved method.

Vent void forms without solid cores to eliminate high air pressure caused by heat of hydration. Insert a 3/4-in. diameter plastic tube into the top of the void before placing concrete, and leave it in place until there is no possibility of damage from pressure. Remove the plastic tube afterwards and seal the hole with an approved repair material and procedure.

Drain prestressed concrete box beams and U-beams through the bottom flange by forming holes in each voided area as shown on the plans.

2. **Prestressing.** Perform prestressing in accordance with Item 426, "Prestressing." Place post-tensioning ducts in accordance with Item 426 and keep ducts free of obstructions.
3. **Placing Reinforcing Steel.** Place reinforcing steel in accordance with Item 440, "Reinforcing Steel." Reinforcing steel projection outside of the member must not be more than 1/2 in. or less than 3/4 in. from plan dimension unless otherwise approved.

Do not damage sheathing for strand debonding. Do not tie reinforcing steel to debonded strand regions.

4. **Quality of Concrete.** Provide concrete in accordance with Item 421, "Hydraulic Cement Concrete," except that air-entrained concrete will not be required in precast concrete members unless otherwise shown on the plans. For each type of structure or unit, use the class of concrete shown on the plans or in the pertinent

Item. When optional designs are permitted, the minimum concrete strength is as shown on the approved shop drawings.

Control concrete by compressive strength tests of cylinders or other pertinent performance tests detailed on the plans or pertinent Items. Concrete compressive-strength test cylinders will be made, cured, and tested in accordance with Tex-704-I. Cure release-of-tension strength cylinders in accordance with Tex-715-I when match-cure technology is used.

High-strength concrete ($f'_c > 9000$ psi) is accepted based on 56-day compressive strength testing. Concrete design-strength test cylinders for high-strength concrete will be made, cured, and tested in accordance with Tex-704-I. However, a maximum of 10 design-strength cylinders are permitted.

Product with concrete that fails to meet minimum design compressive strength requirements will be reviewed. Concrete that has been determined to be structurally adequate may be accepted at an adjusted price based on the formula in Article 420.6, "Payment." If the Engineer requires that cores be taken to determine the strength of the in-situ concrete, the coring will be at the Contractor's expense and will be in accordance with Tex-424-A. For concrete that has been determined to be structurally adequate, coring of the in-situ concrete will not be allowed for the purpose of avoiding the price adjustment. The Department may require reimbursement for testing of cores. Testing by an approved commercial testing laboratory will be at the Contractor's expense. Test results from a commercial laboratory must be sealed by a licensed professional engineer.

5. **Placing Concrete.** Place concrete during daylight hours unless the production site has an approved lighting system.

Place concrete only when its temperature at time of placement is between 50°F and 95°F.

Under any weather condition, the Contractor is responsible for producing quality concrete and must have adequate weather protection provisions on-site and available for immediate use.

If rainfall occurs after concrete placing operations have started, immediately provide protective measures without compromising the quality of the product. Failure to immediately provide adequate weather protection may be cause for rejection of the affected product.

424.3 to 424.3

Maintain concrete transporting equipment clean and free from hardened concrete coatings.

At the time of concrete placement, reinforcing steel, strands, and embedments must be free of dirt, oil, or other bond-breaking substances.

Place and adequately consolidate concrete while it is in a plastic state, which is before the concrete attains initial set as determined in accordance with Tex-440-A. When it is necessary to determine initial set time, including for concrete mix design trial batches per the Department work plan guidelines, perform the test in a manner representative of the concrete temperature at the time of placement.

Concrete must not exhibit segregation or excessive bleeding. Minimize concrete flow lines and displacement of the reinforcing steel, strands, embedments, and ducts during concrete placement.

Place concrete as near as possible to its final position in the forms. Do not deposit large quantities of concrete at one location and run or work it along the forms to other locations.

Do not allow fresh concrete to free-fall more than 5 ft. unless approved.

Work the coarse aggregate back from the face of the concrete, and force the concrete under and around the reinforcing steel, strands, embedments, and ducts. If prestressed concrete I-beams are cast in multiple lifts, the thickness of the first lift must be slightly above the juncture of the bottom flange and web.

Cast prestressed concrete box beams monolithically in 2 stages, maintaining the concrete in the previously placed bottom slab in a plastic state until the web (side wall) concrete is placed and vibrated into the bottom slab.

The maximum time between the addition of mixing water or cement to the concrete batch and the placing of concrete in the forms is 30 minutes for concrete delivered in non-agitated delivery equipment and 60 minutes for concrete delivered in agitated delivery equipment. If conditions of wind, humidity, and temperature cause quick stiffening of the concrete, the required placement times may be reduced. Submit a plan for approval, if necessary, to demonstrate that the concrete can be properly placed, consolidated, and finished without reducing placement time limits.

Unless otherwise specified, the maximum acceptable placement slump will be in accordance with Section 421.4.A.5, "Slump."

When the maximum acceptable placement slump is exceeded, the affected concrete will be rejected and re-slumping will not be allowed regardless of the concrete placement times.

Requirements for precast mass placements will be in accordance with Section 420.4.G.14, “Mass Placements.”

- a. Placing Concrete in Cold Weather.** Maintain concrete temperature between 50°F and 95°F at time of placement as specified in Section 424.3.B.5, “Placing Concrete,” and maintain the concrete temperature of precast members at or above 50°F during the specified curing period as specified in Section 424.3.B.7, “Curing of Concrete.” Do not place concrete when the atmospheric temperature in the shade is below 40°F and falling unless approved. Concrete may be placed when the atmospheric temperature in the shade is at least 35°F and rising or above 40°F, provided that adequate cold-weather protection provisions are on-site and available for immediate use before placing concrete when weather conditions indicate a possible need for temperature protection. When required, provide necessary covering material or an approved accelerated curing system in accordance with Section 424.3.B.7.d, “Accelerated Curing,” and do not allow any concrete to remain unprotected for longer than 1 hour after placement. Do not place concrete in contact with any material coated with frost or with material at a temperature of 32°F or lower. If accelerated curing is used, do not apply heat directly to concrete surfaces. Take protective measures to ensure that the difference between air temperature and concrete surface temperature does not cause thermal cracking.

Maintain aggregates free from ice, frost, and frozen lumps. When needed to produce the minimum concrete placement temperature of 50°F, heat the aggregate and the water, but:

- do not allow the water temperature to exceed 180°F or the aggregate temperature to exceed 150°F,
- heat the aggregate uniformly to eliminate overheated areas in the stockpile that might cause flash set of the cement, and
- provide an aggregate and water mixture temperature between 50°F and 85°F before introduction of the cement.

- b. Placing Concrete in Hot Weather.** Keep concrete at or below 95°F at time of placement in accordance with

Section 424.3.B.5, “Placing Concrete.” Use any of the following methods, as needed, to control the concrete placement temperature:

- Cool the aggregate by sprinkling or fogging (fine mist) with water, shading, or using an approved liquid nitrogen system and procedure.
- Cool the fresh concrete by using chilled mixing water, partially replacing mixing water with shaved or crushed ice, or using an approved system and procedure to discharge liquid nitrogen into concrete during batching.

When the temperature of steel forms, strand, or reinforcing steel is greater than 120°F, apply a fog spray (fine mist) of water to this steel just before placing concrete. Water droplets left on the form surfaces must not adversely affect surface finishes.

Place concrete without exceeding the design water-cement ratio. When field conditions are such that evaporation of water from the concrete makes the surface finishing operation difficult, a fog spray (fine mist) of water may be applied above the concrete surface. Do not fog directly toward the concrete or in any manner that will wash cement paste from the fresh concrete surface or cause water to puddle. Do not fog as a means to add finishing water and do not work moisture from the fog spray into the fresh concrete. An approved evaporation retardant conforming to DMS-4650, “Hydraulic Cement Concrete Curing Materials and Evaporation Retardants,” is also acceptable if used in accordance with the manufacturer’s recommendations. Do not apply the evaporation retardant when floating and troweling concrete. Do not allow it to puddle or be worked into the concrete surface immediately after application. Misuse of fog spray or evaporation retardant will be cause for disallowing its use. If necessary, shade the concrete during casting.

When the air temperature is above 85°F, use an approved retarder, in accordance with the manufacturer’s recommendations, if necessary to control concrete slump loss and lengthen the time for placing, consolidating, and finishing operations.

- c. **Consolidation of Concrete.** Thoroughly consolidate concrete with high-frequency vibration immediately after placement.

For prestressed concrete beams and piling, internal vibration is required and may be supplemented with external vibration.

For emergency use, provide at least 1 on-site standby vibrator of the type being used.

Perform concrete vibration using trained personnel and proper timing and spacing to ensure adequate consolidation. Revise the concrete placement and consolidation procedures, and review the concrete mix design and batching procedures, if necessary, when unacceptable defects such as excessive honeycombing, aggregate or mortar pockets or surface air voids (bugholes) are present. Provide supplemental vibrators or modify the vibration system when required to accomplish thorough consolidation of the concrete and complete embedment of the strands, reinforcing steel, embeddings, or ducts.

- (1) **Internal Vibration.** Insert vibrators into the concrete immediately after concrete placement at points spaced to ensure uniform vibration of the entire concrete mass. Limit the insertion spacing to within the radius where the vibrators are visibly effective. Allow the vibrators to sink into the concrete by their own weight and to penetrate into previously placed lifts that are still in a plastic state in order to thoroughly consolidate the layers together and prevent cold joints. After the concrete is thoroughly consolidated, withdraw the vibrators slowly to avoid forming holes.

Do not allow prolonged contact of vibrators with forms so that vibrator marks on concrete surfaces are minimal. Do not use vibrators to move concrete to other locations in the forms.

When epoxy-coated reinforcing steel is used, use vibrators with nonmetallic vibrating heads to prevent damage to the epoxy coating. Increase the consolidation time and decrease the insertion spacing, if necessary, when using these vibrators.

- (2) **External Vibration.**

- (a) **Form Vibrators.** Form vibrators may be used to consolidate thin members, supplement internal

vibration, or consolidate members with highly congested reinforcing steel.

Determine the size, number, and location of external vibrators to provide enough intensity of vibration to the desired area of the form. Adjust the spacing, frequency, amplitude, and duration of vibration according to the concrete mix and size of member to produce uniform consolidation of the concrete.

(b) Surface Vibrators. Vibratory screeds may be used to consolidate thin sections. Move vibratory screeds at a rate that will bring enough mortar to the surface to embed and cover the coarse aggregate. Do not overvibrate by causing an excessive amount of mortar to be brought to the surface.

(c) Vibrating Tables. Determine the size, number, and location of external vibrators to provide enough intensity of vibration to the desired area of the form. Adjust the spacing, frequency, amplitude, and duration of vibration according to the concrete mix and size of member to produce uniform consolidation of the concrete.

6. Finishing of Concrete. Finished, unformed surfaces must not have distortions greater than 1/4 in.

a. Prestressed Members. Screed or rough-float unformed surfaces of prestressed members and bridge deck panels by bringing enough mortar to the surface to embed and cover the coarse aggregate.

Provide a uniform rough wood float finish for the top surface of box beams and slab beams with exposed reinforcing steel, I-beams, bulb-tee beams, and U-beams.

Provide tine finish of approximately 1/16-in. amplitude or a stiff broom finish for the top surface of box beams and slab beams without exposed reinforcing steel, bridge deck panels, and double-T beams.

Do not loosen aggregate when roughening the surface with a broom or tine finish.

Provide a smooth metal trowel finish for surfaces at anchor bolt locations.

Strike off the top surface of prestressed concrete piling, and finish it with a wood or magnesium float by bringing enough mortar to the surface to cover the aggregate and providing a reasonably smooth appearance.

- b. **Nonstressed Members.** Screed or rough-float unformed surfaces by bringing enough mortar to the surface to embed and cover the coarse aggregate. Provide a uniform rough wood float finish to the surface unless otherwise shown on the plans.

7. **Curing of Concrete.** To promote early cement hydration, cure concrete by providing adequate moisture on exposed surfaces and by maintaining the concrete temperature or curing enclosure air temperature at the concrete surface within the limits specified in this Section. Provide uniform temperature and moisture on the surfaces to prevent differential shrinkage that may cause warping or cracking. Prevent temperature differentials within the concrete that cause thermal cracking.

Begin curing after the finishing operation, before the formation of plastic shrinkage cracks, and as soon as damage to the surface finish will not occur. If needed to prevent plastic shrinkage cracks, provide fog spray or an evaporation retardant after finishing and before curing. Apply fog spray or evaporation retardant in accordance with Section 424.3.B.5.b, "Placing Concrete in Hot Weather." Keep exposed concrete surfaces continuously wet for the duration of the specified curing period, unless an approved liquid membrane-forming curing compound is used. Membrane curing compound is only permitted as noted in this Section or in the pertinent Item.

Approved equipment and materials for curing must be on-site and available for immediate use before placing concrete. Provide temperature probes to monitor the concrete temperature or curing enclosure air temperature as specified in Table 2.

Attach each temperature probe to a separate temperature recording device unless multi-channel temperature recording devices are used, in which case 1 high concrete temperature probe and 1 low concrete temperature probe may be attached to the same recording device. When accelerated curing is used, 1 curing enclosure air temperature probe may also be attached to this multi-channel temperature recording device.

Inadequate curing facilities or lack of attention to the proper curing of concrete will be cause for the Engineer to stop concrete

424.3 to 424.3

placement until approved curing is provided. Inadequate curing may be cause for rejection of the affected product.

Forms may be removed at the discretion of the Contractor at any time after the concrete has reached sufficient strength to prevent physical damage to the member. Do not interrupt curing for more than 30 minutes during form removal.

Table 2
Temperature Probe Requirements

Condition	Major Prestressed Members	Minor Prestressed Members	Nonstressed Members
Forecasted atmospheric temperature $\geq 50^{\circ}\text{F}$ during specified curing period	2 concrete temperature probes per casting line to monitor high concrete temperature regions	2 concrete temperature probes per casting line to monitor high concrete temperature regions ¹	N/A
Forecasted atmospheric temperature $< 50^{\circ}\text{F}$ during specified curing period	2 concrete temperature probes per casting line to monitor high concrete temperature regions, and 2 concrete temperature probes per casting line to monitor low concrete temperature regions ²	2 concrete temperature probes per casting line to monitor high concrete temperature regions ¹ , and 2 concrete temperature probes per casting line to monitor low concrete temperature regions ²	1 concrete temperature probe per 100 cu. yd. of concrete or fraction thereof to monitor low concrete temperature regions ²
Forecasted atmospheric temperature $< 40^{\circ}\text{F}$ during additional 3-day curing period ³	N/A	1 concrete temperature probe per similar curing condition for prestressed piling only	N/A
When accelerated curing is used	2 temperature probes per casting line to monitor curing enclosure air temperature at concrete surfaces ⁴	2 temperature probes per casting line to monitor curing enclosure air temperature at concrete surfaces ⁴	1 temperature probe per 100 cu. yd. of concrete or fraction thereof to monitor curing enclosure air temperature at concrete surfaces

1. Excluding prestressed bridge deck panels and prestressed retaining wall panels.
2. When accelerated curing is used, concrete temperature probes to monitor low concrete temperature regions are not required.
3. After attaining specified release-of-tension strength.
4. These probes are in addition to the concrete temperature probes required for monitoring high concrete temperature regions.

424.3 to 424.3

The following curing requirements apply for prestressed members:

- Cure concrete continuously, except as allowed during form removal, until the compressive strength of the concrete has reached the specified release-of-tension strength and until detensioning has been performed.
- Maintain concrete temperatures between 50°F and 150°F during the curing period. The maximum allowable concrete temperature may be increased to 170°F if the Contractor uses one of the concrete mix design options listed in Section 421.4.A.6, “Mix Design Options,” other than options 6, 7, and 8.
- Membrane curing is permitted only for unformed surfaces of prestressed wall panels and for interim curing on unformed surfaces of prestressed piling. Use Type 1-D or Type 2 curing compound conforming to DMS-4650, “Hydraulic Cement Concrete Curing Materials and Evaporation Retardants,” for this application.
- Water cure prestressed piling an additional 3 days after attaining the specified release-of-tension strength. Do not interrupt curing for more than 4 hours when moving piling to the storage area. Maintain the concrete temperature of piling at 50°F or above during this additional curing period.

The following curing requirements apply for nonstressed members:

- Cure concrete continuously, except as allowed during form removal, for 4 days or until the compressive strength of the concrete has reached the design strength.
- Maintain concrete temperatures between 50°F and 150°F during the curing period. The maximum allowable concrete temperature may be increased to 170°F if the Contractor uses one of the concrete mix design options listed in Section 421.4.A.6, other than options 6, 7, and 8.
- Membrane curing is permitted on nonstressed members, except for surfaces to be painted or color-stained.

Cure precast prestressed and precast nonstressed substructure members, excluding piling, in accordance with Section 420.4.J, “Curing Concrete.”

Cure members immediately for an additional 24 hours if they are out of cure at any time other than during the allowable 30 minutes for form removal or during the allowable 4 hours for moving piling to storage.

Members failing to meet the concrete temperature requirements or curing enclosure air temperature requirements during curing will be reviewed. Repeated failure to maintain proper concrete temperatures may be cause for rejection of the affected product.

- a. **Water Curing.** Water curing provides additional moisture to concrete and prevents moisture loss. Water used for curing must meet the requirements for concrete mixing and curing water specified in Section 421.2.D, “Water.” Do not use seawater or water that stains or leaves an unsightly residue that cannot be removed. Monitor and maintain a temperature differential between curing water and concrete surface temperature that prevents thermal cracking.
 - (1) **Wet Mat Method.** Use water-saturated cotton mats, burlap, burlap-polyethylene sheeting, or other approved moisture-retaining materials. Anchor the wet mats adequately to provide continuous contact with exposed concrete surfaces.
 - (2) **Water Spray Method.** Use overlapping sprays, sprinklers, or soil-soaker hoses so that concrete surfaces are kept continuously wet.
 - (3) **Ponding Method.** Continuously cover the exposed concrete surfaces with standing water.
- b. **Moisture Retention Curing.** Moisture retention curing prevents moisture loss from the concrete.
 - (1) **Form Curing Method.** Concrete surfaces in direct contact with forms that are left in place will not require additional curing methods unless cold-weather protection is necessary.
 - (2) **Impermeable Cover Method.** Cover exposed concrete surfaces with polyethylene sheeting, burlap-polyethylene sheeting, impervious paper, or other approved impermeable materials placed in close contact with concrete surfaces to keep them continuously wet. If this is not enough to keep exposed concrete surfaces continuously wet, then provide additional moisture inside the enclosure in accordance with Section 424.3.B.7.a, “Water Curing.”
- c. **Membrane Curing.** Liquid membrane-forming curing compound is a moisture retention covering that is applied as a

liquid. It is only permitted as noted in Section 424.3.B.7, “Curing of Concrete.”

Use Type 1-D or Type 2 membrane curing compound conforming to DMS-4650, “Hydraulic Cement Concrete Curing Materials and Evaporation Retardants.” Apply membrane curing compound with equipment and in a manner specified in Section 420.3.H, “Spraying Equipment,” and Section 420.4.J.3, “Membrane Curing,” respectively.

When applying membrane curing compound, do not contaminate reinforcing steel, embedments, or concrete surfaces that will later be in direct contact with cast-in-place concrete, unless the curing compound can be completely removed to the satisfaction of the Engineer.

Do not use membrane curing compounds that appreciably stain the concrete.

- d. Accelerated Curing.** Accelerated curing is defined as curing with artificial heat provided to the curing enclosure or forms.

Test accelerated-curing facilities for a minimum of 48 hours to demonstrate that temperature variations do not exceed 20°F between any points in the curing enclosure. Submit accelerated curing facility drawings and test results, and obtain approval before using these facilities for Department work. The test may be performed on the entire casting line with either freshly cast concrete inside the forms or with empty forms. Provide 1 curing enclosure air temperature probe per 100 ft. of casting line when accelerated curing facilities are being tested.

Maintain the air temperature in the curing enclosure between 50°F and 85°F until initial set of the concrete (as determined in accordance with Tex-440-A when establishing mix designs under representative temperature conditions) and for at least 3 hours after concrete placement. The concrete temperature may then be raised uniformly at a maximum rate of 36°F per hour. Provide an unobstructed air space of at least 6 in. between surfaces of the concrete and the curing jacket.

For prestressed and nonstressed concrete members, monitor and maintain the curing enclosure air temperature between 50°F and 160°F during accelerated curing. Do not allow the air temperature to exceed 160°F for more than 1 cumulative

hour during the entire curing period. Do not allow the air temperature to exceed 170°F at any time during the specified curing period. Arrange the location of the heat discharge into the curing enclosure so that temperature variations do not exceed 20°F between any points in the curing enclosure.

Provide curing enclosure air temperature probes to monitor the temperature at the concrete surface as specified in Table 2.

Provide enough moisture inside the curing enclosure to keep exposed concrete surfaces continuously wet for the specified curing period.

If accelerated curing is terminated before the specified curing period has elapsed, provide other acceptable curing methods for the remaining curing period.

- (1) **Steam Curing.** Steam cure in accordance with the requirements of accelerated curing. Position steam outlets so that live steam is not applied directly on the concrete, forms, or test cylinders.
- (2) **Alternate Methods.** Other methods of accelerated curing, such as the use of radiant heaters or portable heater, may be permitted if they meet the requirements of accelerated curing. The use of any alternate method requires written approval.

- C. Workmanship.** Formed surfaces must not have excessive surface honeycombing, aggregate or mortar pockets, air voids, lift lines, or vibrator marks. Remove form-joint-offset marks in excess of the tolerances specified in Section 424.3.B.1.a, “External Forms,” and fins and rough edges along chamfer lines, in a manner that will not damage the member. Repair fabrication holes, except box beam and U-beam drain holes, with an approved repair material and procedure.

Unless otherwise shown on the plans, recess strands approximately 3/8 in. without overheating or damaging the surrounding concrete. Clean and coat the inside of each 3/8-in. recess and strand end with approximately 10 mils of Type VIII neat epoxy conforming to DMS-6100, “Epoxy and Adhesives,” and fill with epoxy grout while the neat epoxy is still tacky. Furnish epoxy grout with the same type of epoxy and dry, clean sand. Submit for approval any other moisture-barrier systems for protecting strands.

Before shipment of members, remove:

- concrete, paste, dirt, oil, or other bond-breaking substances from exposed reinforcing steel, and
- laitance, dirt, oil, or other bond-breaking substances from concrete surfaces to be in contact with cast-in-place concrete.

1. Defects and Breakage.

- a. Prestressed and Nonstressed Members.** Members that sustain damage or surface defects during fabrication, handling, storage, hauling, or erection are subject to review. Submit proposed written repair procedures and obtain approval before performing repairs. Repair work must reestablish the member's structural integrity, durability, and aesthetics to the satisfaction of the Engineer.

When damage occurs, determine the cause and take corrective action. Failure to take corrective action, leading to similar repetitive damage, could be cause for rejection of the damaged members.

Cracks that extend to the nearest reinforcement plane and fine surface cracks that do not extend to the nearest reinforcement plane but are numerous or extensive are subject to review.

- b. Prestressed Members.** Failure of individual wires in a 7-wire strand is acceptable if the total area of wire failure is not more than 2% of the total cross-sectional area of all strands in the member, and if no more than 1 wire fails in any single strand. Any setup with one or more broken wires must be examined by a licensed professional engineer or Quality Control Supervisor (as defined in DMS-7300, "Precast Concrete Fabrication Plants") to determine the cause before continuing stressing operations on the particular casting line.

Vertical or horizontal cracks 1/16 in. or less in width that tend to close upon transfer of stress to the concrete are acceptable. Cracks that do not tend to close are subject to review.

Prestressed bridge deck panels will be rejected for any of the following conditions:

- any crack extending to the reinforcing plane and running parallel and within 1 in. of a strand for at least 1/3 of the embedded strand length; or
- any transverse or diagonal crack, including corner cracks and breaks, intersecting at least 2 adjacent strands and extending to the reinforcing plane.

Prestressed bridge deck panels that sustain damage or surface defects during fabrication, handling, storage, hauling, or erection are subject to review.

2. Tolerances.

- a. Prestressed Members.** Allowable tolerances for the dimensions and configurations shown on the plans or approved shop drawings are shown in Table 3.

Table 3
Allowable Tolerances for Prestressed Members

Dimension	I-Beams and Bulb-Tee Beams	U-Beams	Box and Slab Beams	Double-T Beams	Bridge Deck Panels	Piling	Wall Panels¹
Length (perpendicular to strands for bridge deck panels)	±3/4"	±1"	±1"	±3/4"	±1/2"	-1" ²	±3/16"
Width (parallel to strands for bridge deck panels)	+3/4" -1/4"	±1/4"	±1/4"	±1/2"	±1/2"	±1/4"	±3/16"
Nominal depth (thickness in case of panels)	+1/2" -1/4"	±1/4"	±1/4"	±1/4"	+1/4" -1/8"	±1/4"	±3/16"
Thickness: top slab or flange	+1/2" -1/4"	±1/2"	±1/2"	±1/4"	NA	NA	NA
Thickness: bottom slab or flange	+1/2" -1/4"	±1/2"	±1/2"	NA	NA	NA	NA
Thickness: web or wall	+3/4" -1/4"	±1/2"	±1/2"	±1/4"	NA	NA	NA
Horizontal alignment (deviation from straightness of all panel edges)	±1/8" per 10' of length	±1/8" per 10' of length, 3/4" max.	±1/4"	±1/4"	±1/8"	±1/8" per 10' of length	±1/8" per 10' of length, 1/2" max.
Deviation of ends (horizontal skew)	±1/4"	±1/8" per 1' of width, 1/2" max.	±1/8" per 1' of width, 1/2" max.	±1/8" per 1' of width, 1/2" max.	±1/2"	±1/8"	±1/4" per 5' of width, 1/2" max.
Deviation of ends (vertical batter)	±1/8" per 1' of depth, 1/2" max.	±1/8" per 1' of depth, 1/2" max.	±1/8" per 1' of depth, 1/2" max.	±1/8" per 1' of depth, 1/2" max.	NA	±1/8"	±1/4"

Table 3 (continued)
Allowable Tolerances for Prestressed Members

Dimension	I-Beams and Bulb-Tee Beams	U-Beams	Box and Slab Beams	Double-T Beams	Bridge Deck Panels	Piling	Wall Panels¹
Notched end areas (for diaphragms): depth	±1/4"	NA	±1/4"	±1/4"	NA	NA	NA
Notched end areas (for diaphragms): length	+2" -1"	NA	+2" -1"	+2" -1"	NA	NA	NA
Bearing surfaces: perpendicular to vertical axis	±1/8"	NA	NA	±1/16"	NA	NA	NA
Bearing surfaces: deviation from plane	±1/16"	±1/8"	±1/8"	±1/16"	NA	NA	±1/16 ³
Anchor hole location: from end of member	+3/4" -1/4"	±1/4"	±1/4"	+3/4" -1/4"	NA	NA	NA
Anchor hole location: longitudinal spacing	±3/4"	±1/2"	±1/2"	±3/4"	NA	NA	NA
Anchor hole location: transverse location	±1/4"	±1/4"	±1/4"	±1/4"	NA	NA	NA
Diaphragm or lateral tie location	±1/2"	NA	±1/2"	±1/2"	NA	NA	NA
Position of internal void form (longitudinal for box beams and U-beams)	NA	±1"	±1" ^{4,5}	NA	NA	±1/2"	NA
Projection of reinforcing steel outside of member	+1/2" -3/4"	+1/2" -3/4"	+1/2" -3/4"	+1/2" -3/4"	+1/2" -3/4"	NA	+1/2" -3/4"
Position of strands: vertical	±1/4" ⁶	±1/4"	±1/4"	±1/4"	±1/8" ⁷	±1/4"	±1/8"

Table 3 (continued)
Allowable Tolerances for Prestressed Members

Dimension	I-Beams and Bulb-Tee Beams	U-Beams	Box and Slab Beams	Double-T Beams	Bridge Deck Panels	Piling	Wall Panels¹
Position of strands: horizontal	±1/4"	±1/4"	±1/4"	±1/4"	±1/2"	±1/4"	±1/2"
Debonded length of strands	±3"	±3"	±3"	±3"	NA	NA	NA
Position of strand hold-down points	±6"	±6"	±6"	±6"	NA	NA	NA
Position of handling devices: parallel to length	±6"	±6"	±6"	±6"	As shown on plans	±6"	±6"
Position of handling devices: transverse to length	±1"	±1"	±1"	±1"	As shown on plans	±1"	±1"
Local flatness of formed surfaces (excluding bearing surface)	±1/4" in 10'	±1/4" in 10'	±1/4" in 10'	±1/4" in 10'	±1/4"	±1/4" in 10'	±1/4" in 10'
Bow (length and width)	NA	NA	NA	NA	NA	NA	±1/4" per 10'

1. Prestressed and nonstressed wall panels (tie back, C-wall, sound wall, etc.) except MSE wall panels.
2. Maximum length as approved.
3. Measured along the panel depth at the top and bottom panel sides.
4. Voided box beams only.
5. Length of box beam internal void form +1", -6".
6. For draped strands, the tolerance for vertical position of strands at the end of the beam may be increased to ±1/2" provided the tested concrete compressive strength, before release of tension into the member, is at least 5% greater than the release-of-tension strength shown on the plans.
7. Measured from bottom of panel.

Variations greater than those specified in Table 3 are subject to review. However, these tolerances do not relieve the

Contractor from the responsibility of furnishing a completed structure that is in reasonably close conformity with the lines, grades, cross-sections, dimensions, and details specified. Correct members not meeting these tolerances at no additional expense to the Department, to achieve a satisfactory completed structure. This also includes costs for correction due to variations in vertical beam camber. Correction may require replacement of the member.

Horizontal misalignment (sweep) in beams, which may increase at a later time and exceed the tolerance shown in Table 3, may be acceptable if the members can be hauled, erected, and aligned to within the allowable tolerance without being damaged. Store these members in a manner that will minimize the sweep.

Embedments must be firmly held in proper position to avoid movement during concrete placement. Place embedments in accordance with the manufacturer's recommendations. Place weld clip inserts for permanent metal deck forming no more than 1/16 in. from the beam edge.

- b. Nonstressed Members.** Unless otherwise shown on the plans, the allowable tolerances for nonstressed members are as specified in Table 4. The allowable tolerances for nonstressed wall panels, except MSE wall panels, are as specified in Table 3.

Table 4
Allowable Tolerances for Nonstressed Members

Member	Dimension	Tolerance
MSE wall panels and wall components ¹ (coping, posts, etc.)	All dimensions (including deviation from edge straightness)	±3/16 in.
	Deviation of ends (horizontal skew)	±1/4 in. in 5 ft., ±1/2 in. max.
	Local flatness of formed surfaces	±1/8 in. in 5 ft.
	Connection hardware	±1/2 in.

1. Includes wall components for tie-back walls, C-walls, sound walls, etc.

- D. Storage and Handling.** Immediately after form removal, mark members for identification as shown on approved shop drawings in accordance with the requirements of the pertinent Items or as required. Inspect members immediately before shipping to the job site for damage that may have occurred in storage.

424.4 to 425.2

1. **Prestressed Members.** Store and handle prestressed members in accordance with Item 425, "Precast Prestressed Concrete Structural Members."
2. **Nonstressed Members.** Store and handle nonstressed members in a manner to avoid excessive bending stresses and damage.

The storage area must be clean and well drained. Prevent excessive or differential settlement of members by storing them on stable ground and on dunnage of sufficient size, shape, and strength, to prevent crushing.

When members are stacked, separate them with blocking, arranged in vertical planes, that does not crush under load. Stack members so that lifting devices are accessible and undamaged.

Rearrange improperly stored members and inspect them for damage. Members that are improperly stored and become cracked, warped, or otherwise damaged in storage may be cause for rejection.

Dunnage and blocking material must not cause damage or stains that are unacceptable for the required finish.

424.4. Measurement and Payment. The work performed, materials furnished, equipment, labor, tools, and incidentals will not be measured or paid for directly but will be subsidiary to bid items of the Contract.

ITEM 425

PRECAST PRESTRESSED CONCRETE STRUCTURAL MEMBERS

425.1. Description. Furnish and erect precast prestressed concrete members fabricated by pretensioning, post-tensioning, or a combination of the two.

425.2. Materials. Use materials that meet requirements of the following Items:

- Item 421, "Hydraulic Cement Concrete"
- Item 426, "Prestressing"
- Item 434, "Elastomeric Bridge Bearings"
- Item 440, "Reinforcing Steel"
- Item 442, "Metal For Structures"

- DMS-4650, “Hydraulic Cement Concrete Curing Materials and Evaporation Retardants”
- DMS-6100, “Epoxies and Adhesives.”

The bedding strip for precast prestressed concrete bridge deck panels must be extruded polystyrene conforming to ASTM C 578, Type VI, with:

- maximum water absorption of 0.1% by volume tested in accordance with ASTM C 272 and
- minimum compressive strength of 40 psi tested in accordance with ASTM D 1621 by loading the bedding strip sample perpendicular to the skin (bearing) face.

Provide a manufacturer’s certification stating that the bedding strip meets the requirements of this Item. Use adhesive or bonding agents for polystyrene as recommended by the polystyrene manufacturer.

Use other materials as panel bedding strips only after submitting suitable data for structural review and approval.

The dimensions for panel bedding strips must conform to those shown on the plans.

425.3. Construction. Fabricate precast prestressed concrete members in accordance with Item 424, “Precast Concrete Structures (Fabrication).”

- A. Handling, Storing, Hauling, and Erection.** Properly handle, store, haul, and erect all members so that they are placed in the structure without damage.

Unless approved on shop or erection drawings, maintain members in an upright position at all times, and raise and support them near the ends to prevent torsion. Lift members with approved lifting devices as shown on the shop drawings or as approved.

Do not move members from the casting yard until all requirements of the pertinent items have been met. Do not haul beams to the project site until at least 7 days have elapsed since casting unless otherwise approved.

The storage area must be clean and well drained. Prevent excessive or differential settlement of members by storing them on:

- stable ground and
- dunnage of sufficient size, shape, and strength to prevent crushing.

Place dunnage a distance not greater than 3% of the beam length from the beam ends. When approved, cantilever beams may be supported at locations other than near the ends. Support concrete box beams and

425.4 to 425.5

U-beams under the solid end block area during handling, storage, hauling, and erection.

When members are stacked, separate them with blocking arranged in vertical planes that will not crush under load. Stack members so that lifting devices are not damaged.

Rearrange improperly stored members and inspect them for damage. Members that are improperly stored and become cracked, warped, or otherwise damaged in storage may be rejected.

Securely tie or brace all beams during erection in accordance with minimum erection and bracing standards. When railroad or roadway traffic must be maintained beneath beams already placed, protect traffic against falling objects during the erection of diaphragms and other structural members, during the placing of cast-in-place concrete, and during the erection and dismantling of forms. Protect traffic with nets or flooring with openings not larger than 1 in., or as approved.

When erecting precast prestressed concrete bridge deck panels, fit mating surfaces to prevent excessive grout leakage. If such fit is not provided, fill the joint with grout or seal it with an acceptable caulking compound before placing the cast-in-place portion of the slab.

After slab placement, finish surfaces of beams or other members in accordance with Section 420.4.M, "Ordinary Surface Finish," and Item 427, "Surface Finishes for Concrete."

Correct beam discrepancies including but not limited to horizontal misalignment or variations in vertical camber, to achieve a satisfactory completed structure, at no additional expense to the Department. Correction may require replacement of the member.

425.4. Measurement. This Item will be measured by the foot, square foot, square yard, cubic yard, or each member.

This is a plans quantity measurement Item. The quantity to be paid is the quantity shown in the proposal, unless modified by Article 9.2, "Plans Quantity Measurement." Additional measurement or calculations will be made if adjustments of quantities are required.

425.5. Payment. The work performed and materials furnished in accordance with this Item and measured as provided under "Measurement" will be paid for at the unit price bid for "Prestressed Concrete" of the specified structural component and type or size. This price is full compensation for fabricating, hauling, and erection of the members; furnishing and tensioning of prestressing steel; furnishing and placing

reinforcing steel and duct; furnishing and placing bearing plates, elastomeric bearings, bars, anchorage plates, and appurtenances; grouting holes; repairs; special treatment of end anchorages and shoes as required; erection bracing; and equipment, labor, tools, and incidentals.

Precast prestressed concrete bridge deck panels will not be paid for directly but will be subsidiary to pertinent Items.

Precast prestressed concrete piling will be paid for as specified in Item 409, "Prestressed Concrete Piling."

ITEM 426 PRESTRESSING

426.1. Description. Furnish, store, and handle prestressing materials and perform prestressing of precast members and cast-in-place structural units. For this Item, the following definitions apply:

- **Prestressing.** The introduction of internal stresses (pretensioning or post-tensioning) into a structural member by tensioning and anchoring strands, bars, or wires to counteract the stresses resulting from the applied load.
- **Pretensioning.** The application of prestressing force to the tensioning devices before casting concrete.
- **Post-Tensioning.** The application of prestressing force to the tensioning devices after concrete has hardened.
- **Tendon.** Any single unit used to apply prestressing force to the member. For post-tensioned units, a tendon is a bar, group of wires, or group of strands having common end anchorage.
- **Post-Tensioning System.** A complete tendon with couplers, end anchorage, and all other necessary hardware.

426.2. Materials. Furnish materials that meet requirements of the following Items:

- Item 420, "Concrete Structures"
 - Item 421, "Hydraulic Cement Concrete"
 - Item 434, "Elastomeric Bridge Bearings"
 - Item 440, "Reinforcing Steel"
 - Item 442, "Metal For Structures"
 - DMS-4670, "Grouts for Post-Tensioning"
 - DMS-6310, "Joint Sealants and Fillers."
- A. Prestressing Hardware.** Furnish prestressing hardware that meets the manufacturer's specifications.

426.2 to 426.2

- B. Concrete.** Furnish concrete of the class shown on the plans.
- C. Prestressing Steel.** Furnish prestressing steel conforming to one of the following types:
- 7-wire steel strand meeting DMS-4500, “Steel Strand, Uncoated Seven-Wire Stress Relieved and Low Relaxation for Prestressed Concrete,”
 - alloy bars meeting ASTM A 722, or
 - steel wire meeting ASTM A 421.

When shown on the plans or permitted by approval of optional design, use stress-relieved 7-wire strand.

Furnish a copy of the manufacturer’s certified Domestic Certification Form D-9-PS-1 for 7-wire steel strand. Use 7-wire steel strand produced by a prequalified manufacturer on the list maintained by the Construction Division. The Department may take samples in accordance with Tex-710-I to verify compliance with specification requirements.

Test prestressing material per the applicable ASTM standards. Furnish project samples of prestressing bar and prestressing wire for testing in accordance with Section 426.4.B.1, “Prestressing Steel Bar and Wire Samples.”

Assign an individual lot number to all bars from each size and heat, all wire from each coil, and all strand from each reel, and tag the material for accurate identification at the jobsite. Identify each lot of anchorage assemblies and couplers in a similar manner. Unidentified prestressing steel, anchorage assemblies, or couplers received at the site will be rejected. Loss of positive identification of these items at any time will be cause for rejection.

- D. Post-Tensioning System.** Furnish a post-tensioning system as required by this Item and the plans. The system selected must provide the magnitude and distribution of prestressing force and ultimate strength required by the plans without exceeding allowable temporary stresses. Provide grouted or ungrouted post-tensioned tendons as shown on the plans. Use tendon couplers only at locations shown on the plans or approved by the Engineer.

Post-tensioning systems must be pre-qualified before use on the project. Prequalification will consist of tests on the complete tendons for compliance with the requirements of this Section for grouted tendons and ungrouted tendons. Have these tests performed by an approved testing laboratory. For post-tensioning systems previously

tested and approved on Department projects, complete tendon samples are not required if there is no change in material, design, or details previously approved. Identify on shop drawings or prestressing details the project where approval was obtained. Perform prequalification testing at the Contractor's expense, and provide written certified results.

1. **Grouted Tendons.** Provide post-tensioning systems with grouted tendons that develop at least 95% of the required ultimate strength of the tendon with a minimum elongation of 2% of the gauge length when tested in the unbonded condition. Include tendon couplers, when permitted, in the test.

Ducts and all connections must be capable of withstanding the pressures required for the grouting operation and the test pressures specified in Section 426.4.D.1, "Internal Duct Pressure Test," and Section 426.4.D.3, "Duct Connection Pressure Field Test." Ducts must be watertight and strong enough to withstand concrete placement and grouting without damage or excessive deformation.

Size the ducts so that the nominal internal area of the duct is at least 2.5 times the area of the prestressing steel for multiple strand and wire tendons. The minimum inside duct diameter must be at least 3/8 in. larger than the outside diameter of a single-bar or single-strand tendon.

Provide connections of couplers and transition fittings that are adaptable to various duct materials, air tight, water tight, and strong enough to prevent distortion or displacement of the ducts during concrete placement or tendon grouting. Equip ducts with:

- fittings at each end of the tendon for injection of grout and
- ports for venting or grouting at high points and for draining at intermediate low points.

Vents and drains must be at least:

- 3/4 in. in diameter for strand tendons in round ducts and
- 1/2 in. in diameter for single-bar tendons, single-strand tendons, and strand tendons in flat ducts.

Vents and drains must have a positive shutoff to allow injection of grout through the vents and sealing to prevent grout leakage.

Equip all grouted tendon anchorages with permanent fiber reinforced plastic grout caps that are vented and bolted to the anchorage. Grout caps must completely cover and seal all exposed metal parts of the anchorage. Seal the cap with neoprene "O" ring

seals against the bearing plate, and place a grout vent on the top of the cap. Ensure that permanent grout caps have sufficient anti-oxidant additives. Certify the cap material for environmental stress cracking per ASTM D 1693, Condition C. Caps must have an endurance rating of 192 hr. and be rated for a minimum pressure rating of 150 psi. Use ASTM F 593 Alloy 316 stainless steel bolts to attach the cap to the anchorage.

- a. **Plastic Ducts.** Do not use plastic ducts made from recycled material. Plastic duct material must not have an adverse chemical reaction with concrete, prestressing steel, or grout. Use seamless fabrication methods to produce plastic ducts. Provide a manufacturer's certification stating that the plastic ducts and connections meet the material requirements of this Item.

- (1) **Internal Plastic Ducts.** Plastic ducts for tendons completely embedded in concrete must be semi-rigid, corrugated, and made of unfilled polypropylene meeting the requirements of ASTM D 4101, cell classification range PP0346B44544 to PP0346B65884. Certify that the polypropylene contains 0.2% hindered amine light stabilizer, non-yellowing type, and that the environmental stress cracking will not be less than 192 hr. as determined by ASTM D 1693, Condition C. Provide corrugated duct with a minimum wall thickness of 0.08 in.

Provide a manufacturer's certification that the internal plastic duct can be bent to the radii shown on the plans. Have the manufacturer test the duct to determine the minimum bending radius. Provide a 1/2 in. diameter 270 ksi strand stressed to 75% guaranteed ultimate tensile strength (GUTS) bearing on an ungrouted duct for a length range of 2 to 4 ft. for the testing. Perform the test for a 7-day period. After test completion, remove the duct and measure the wall thickness along the strand path. The wall must be at least 0.06 in. thick in this area.

Provide connections from materials containing antioxidant stabilizers and having an environmental stress cracking not less than 192 hr. as determined by ASTM D 1693, Condition C. Make all connections with devices or methods that produce a smooth interior alignment and

an airtight sealed connection with no lips or kinks. Do not use duct tape to join or repair connections.

- (2) **External Plastic Ducts.** Plastic ducts for tendons not embedded in concrete must be smooth and made of polyethylene material meeting the requirements of ASTM D 3350 with a minimum cell class of 344464C. Provide smooth duct manufactured to ASTM D 3035 or ASTM F 714, with a dimension ratio (DR) of 17.0.

Make all connections using heat-welding techniques in accordance with the duct manufacturer's recommendations or by other methods. Ensure all connections have a pressure rating of 100 psi, producing a smooth interior alignment and an airtight sealed connection with no lips or kinks. Connections with plastic couplers must meet the material requirements of external plastic ducts.

- b. **Steel Ducts.** Steel pipe must conform to ASTM A 53, Grade B, Schedule 40 and be galvanized per Item 445, "Galvanizing."
- c. **Grout.** Grout must be prepackaged and meet the requirements of DMS-4670, "Grouts for Post-Tensioning." Prepackage grout in plastic lined or coated bags. Grout bags must indicate brand name, date of manufacture, lot number, and mixing instructions. Do not use material more than 12 mo. old. Furnish a copy of the manufacturer's quality control data sheet for each lot number and shipment of grout. Use grout produced by a prequalified manufacturer on the list maintained by the Construction Division. Furnish project samples of grout for testing in accordance with Section 426.4.B.2, "Grout Samples."

Have the prepackaged grout materials delivered in bags and stored in a building, bin, or other location that is both waterproof and convenient to the work location. Open storage may be permitted if a raised platform and suitable waterproof covering is used. Use prepackaged grout materials within 30 days of receipt.

2. **UngROUTED Tendons.** Provide post-tensioning systems with ungrouted tendons that develop at least 95% of the required ultimate strength of the tendon with a minimum elongation of 2% of the gauge length, and that withstand 500,000 cycles in a stress

426.3 to 426.3

range of 0.6 to 0.7 F'_s , where F'_s is the guaranteed ultimate tensile strength of the tendon, without failure or slippage. Include tendon couplers when permitted in the test.

Coat ungrouted tendons with a nonvolatile, low-friction mineral oil-base grease having a rust-preventing additive of relatively uniform viscosity at temperature ranges of 20°F to 120°F. Provide a protective sheathing around the tendon consisting of a waterproof material capable of maintaining the tendon tightly bundled and containing the lubricant.

426.3. Equipment.

A. Prestressing Equipment. Furnish hydraulic jacks with sufficient capacity for prestressing the steel. Equip the jacks with instruments for monitoring the hydraulic pressure. Provide gauges at least 6 in. in diameter and with means to prevent the gauge pointer from fluctuating. Electronic pressure transducers with digital indicators may be used. Pressure gauges or electronic pressure indicators must indicate the load directly to 1% of the maximum gauge or sensor/indicator capacity or 2% of the maximum load applied, whichever is smaller.

Calibrate each jack and its gauge with the cylinder extension in the approximate position at final jacking force. Jacks and gauges for post-tensioning and single-strand pretensioning must be calibrated as a unit. Have certified calibration charts furnished by an independent laboratory and with each jack and gauge used on the project. Provide certified calibration of each ram before starting stressing operations on the project and:

- every 6 mo. thereafter for post-tensioning operations,
- every 12 mo. thereafter for pretensioning operations, and
- as requested by the Engineer.

The calibration frequency for multiple-strand pretensioning equipment may be extended to every 24 mo. thereafter if an approved master gauge system monitors it. The master gauge must check this equipment when suspect results occur and at least every 6 mo. Calibrate the master gauge per the manufacturer's recommendations and at least every 12 mo.

Recalibrate jacks and gauges when a malfunction occurs, when repairs such as replacing the seals, changing the length of the hydraulic lines, or changing the pump occur, or when using gauges that have not been calibrated with the jack. Extra compensation will not be allowed for the initial or subsequent calibrations.

For post-tensioning, the jacks must have provisions for measuring tendon elongation directly on the strand, bar, or wire. The jacks must be capable of slow release of force to properly seat the tendon anchors.

For pretensioning, multiple-strand stressing jacks must have sufficient capacity to provide the required stressing force and to permit simultaneous release of all straight strands if multiple-strand detensioning is performed. Single-strand stressing jacks for pretensioning must have provisions for measuring the elongation directly on the strand.

- B. Grouting Equipment.** Use a high-speed shear or colloidal mechanical mixer, capable of continuous mixing that meets the grout manufacturer's recommendations and that will produce a grout free of lumps and undispersed cement. Provide equipment that will accurately measure solid and liquid contents to batch all materials.

Use grouting equipment with gravity feed to the pump inlet from a hopper attached to and directly over it. Use a screen with clear openings of 1/8 in. or less for screening the grout before entering the pump.

Use a positive-displacement pump that can provide an outlet pressure of 150 psi. The pump must have a system for continuous agitation of the grout and be fitted with a valve that can be locked off without loss of pressure in the duct and hoses. Attach a pressure gauge that can read up to 300 psi to the grout line between the pump outlet and the duct inlet.

Under normal conditions, the grouting equipment must be able to continuously grout the longest tendon on the project in less than 20 min. Provide standby grout mixer and pump.

426.4. Construction. The requirements of Item 420, "Concrete Structures," will govern for cast-in-place construction, and Item 424, "Precast Concrete Structures (Fabrication)," will govern for precast concrete units or members.

Before stressing, furnish certified copies of load calibration curves on all jacks and gauge systems to be used in the work.

- A. Required Submittals.** Submit information required in this Section for cast-in-place prestressed units, in addition to forming and falsework plans required by Item 420, "Concrete Structures." Include all necessary construction information in these submittals for cast-in-place

426.4 to 426.4

and precast construction including but not limited to the information required in this Section.

Submit the post-tensioning details and grouting plan on 11 in. × 17 in. sheets. Design calculations may be on standard letter-size sheets.

Submit 7 sets of the post-tensioning details and grouting plan and 3 sets of design calculations for approval. Submit 1 additional copy of each if the owner is a non-Department entity such as a railroad or a municipal or turnpike authority, and another copy if the designer is a private consultant.

- 1. Design Calculations.** Provide design procedures, coefficients, allowable stresses, and tendon spacing and clearances in accordance with the AASHTO *Standard Specifications for Highway Bridges* or AASHTO *LRFD Bridge Design Specifications* unless otherwise shown on the plans. Submit sufficient calculations to support the proposed system and method of prestressing including friction loss diagrams. When the required jacking force for a particular type of tendon, duct, and configuration is furnished as shown on the plans, do not submit design calculations except to adjust for conditions different from those shown on the plans.
- 2. Post-Tensioning Details.** Provide drawings with details of type, size, and number of strand, bar, or wire per tendon; tendon location and identity mark; jacking forces; lubricated tendons; seating loss; end anchorage systems; tendon profile; total elongation; measurable elongation; and other information necessary to complete the work. Adjust calculations for elongation based on the modulus of elasticity given for the strands or, when a bench test is specified, the apparent modulus derived from the bench test.

Submit a numbered layout and a step-by-step stressing sequence for the tendons that prevents overstressing the member in vertical or lateral bending. Identify members to be partially post-tensioned, including the stressing amount and the stressing sequence for partial post-tensioning. Make complete provisions for each stressing operation beginning with prestressing steel installation and ending with excess strand removal at the anchors. Furnish all tendon stressing data for each structure in tabular form.

Include in the post-tensioning details the location and support method for the duct to ensure proper position of the enclosed steel center of gravity. Show:

- the offsets from the bottom of the duct relative to the position of the prestressing steel within the duct and
- the distance from the face of the member to the nearest part of the duct.

Submit post-tensioning details reflecting the following general tensioning procedure, modified for each particular installation:

- Do not allow the modulus of elasticity to vary by more than 1% for any 2 strands within a tendon.
 - Tension the tendons in the sequence designated in the approved post-tensioning details.
 - Apply initial tension, to take the slack out of the tendons, between 10% and 20% of the final load.
 - Reference-mark the tendons to determine elongation after the initial tensioning.
 - Measure the elongations to determine tendon acceptance after tensioning to the specified jacking force. Seat tendon anchors after tendon acceptance.
 - Trim projecting tendon strand tails as required in Section 426.4.D.2, "Prestressing Steel Installation for Post-Tensioning," immediately after stressing and anchoring all tendons. Install grout caps immediately after trimming the tendons.
3. **Grouting Plan.** Submit for approval written grouting procedures at least 4 weeks before starting grouting operations. Include:
- type, quantity, and brand of materials to be used including all required certifications and laboratory test results on the grout materials;
 - type of equipment needed including provisions for backup equipment;
 - types and locations of grout inlets, outlets, and vents;
 - duct cleaning methods before grouting (water flushing of tendon is not permitted);
 - internal duct repair procedures due to pressure test failures;
 - duct connection repair procedures for external tendons due to pressure test failures;
 - mixing and pumping procedures;
 - direction of grouting;
 - sequence of use of the inlets and outlets;
 - procedures for handling blockages due to grouting interruptions, etc. (water flushing of tendon is not permitted);

426.4 to 426.4

- procedures for possible secondary grouting (vacuum-grouting process); and
- names of people responsible for grouting operations including their relevant experience and a certification that they have attended an American Segmental Bridge Institute (ASBI) Grouting Certification Seminar.

B. Project Samples.

1. **Prestressing Steel Bar and Wire Samples.** For post-tensioning applications only and unless otherwise shown on the plans, the Department will sample and test bar and wire for ultimate strength. These samples will be taken according to Tex-710-I. Submit a certification stating the manufacturer's guaranteed ultimate tensile strength and modulus of elasticity with each prestressing steel bar or wire sample. If the test results indicate the need for check tests, furnish additional samples without cost to the Department. For prefabricated tendons, notify the Engineer to arrange sampling and testing at least 10 days before installing end fittings or heading wires.
2. **Grout Samples.** The Department will sample and test each brand of grout furnished at the project site. Testing will be performed by the Construction Division to verify compliance with the material requirements of DMS-4670, "Grouts for Post-Tensioning."

C. Packaging, Storing, and Handling of Prestressing Steel. Protect prestressing steel against physical damage and rust or other results of corrosion, from manufacture to grouting or encasing in concrete. Prestressing steel with physical damage will be rejected. Replace any reel containing broken wires. Provide wire that is bright and uniformly colored, without foreign matter or pitting on the surface.

Package prestressing steel in containers or shipping forms for protection from physical damage and corrosion during shipping and storage. A corrosion inhibitor must be:

- placed in the package or form,
- incorporated in a corrosion inhibitor carrier type packaging material, or
- applied directly to the steel when permitted.

The corrosion inhibitor must not have deleterious effect on the steel, concrete, or bond strength of steel to concrete. Inhibitor carrier-type packaging material must conform to the provisions of federal specification MIL-PRF-3420G. Immediately replace damaged packaging or forms, or restore them to original condition.

Have the shipping package or form clearly marked with the corrosion inhibitor type, packaging date, and a statement that the package contains high-strength prestressing steel.

Handle prestressing steel carefully to avoid abrading, nicking, or kinking the strand, bar, or wire. Protect prestressing steel from damage and corrosion by storing it above the ground on platforms, skids, or other approved supports. Any pitting or tightly adhering rust on prestressing steel will be cause for rejection of the steel. Do not weld or torch-cut near any prestressing steel, so that it is not exposed to weld spatter, direct heat, or short-circuited current flow.

When prestressing steel for post-tensioning is installed in the ducts, any rust that forms during the first 14 days after installation will not be cause for rejection of the steel.

D. Duct and Prestressing Steel Installation for Post-Tensioning.

Securely tie ducts in position, and carefully inspect and repair as necessary before placing concrete. Exercise care during concrete placement to avoid damaging or displacing the ducts. Support ducts at maximum 24-in. intervals. Provide method and spacing of supports per the approved post-tensioning details. Position tendons to a vertical and horizontal tolerance of $\pm 1/4$ in. After installing the forms, seal the duct ends to prevent entry of water, debris, and concrete. If conflict exists between the reinforcement and the post-tensioning ducts, the position of the post-tensioning ducts take precedence over the reinforcing steel. Adjust conflicting reinforcing steel as approved. Do not flush ducts with water at any time.

- 1. Internal Duct Pressure Test.** Before installing the prestressing steel inside internal ducts and casting concrete, seal or plug the ducts and pressurize them to 5 psi from the inlet pipe. Hold this pressure for at least 5 min. If there is a pressure loss exceeding 2 psi, repair the leaks according to the approved grouting plan and retest before casting concrete. The internal duct pressure test is not required for internal longitudinal ducts of segmental units.
- 2. Prestressing Steel Installation for Post-Tensioning.** Open low point duct vents to drain any moisture before installation of prestressing steel. Blow the ducts with oil-free compressed air or other approved methods to remove water and debris.

Push or pull the strands into the duct to make up a tendon using methods that will not snag on any lips or joints in the ducts. Strands may also be pre-assembled into tendons and pulled into the duct using a special steel wire sock (“Chinese finger”) or other

426.4 to 426.4

device attached to the end. Do not weld the strands together for this purpose. Cut excess strands using an abrasive saw or equal. Do not flame-cut strands. Close all duct vents after installing prestressing steel.

Stress the tendons within 1 day (24 hr.) after installing the steel in the ducts. Follow the tensioning procedure noted in the approved post-tensioning details. Tension the post-tensioning steel with hydraulic jacks so the force of the steel will not be less than the value shown on the approved working drawings. The maximum temporary tensile stress (jacking stress) in the post-tensioning steel must not exceed 80% of the specified ultimate tensile strength of the steel. Size tendons based on the jacking stress shown on the plans. Anchor post-tensioning steel at stresses (initial stresses) that provide long-term retention of permanent forces not less than those shown on the approved working drawings. The initial stress after anchor set must not exceed 70% of the specified ultimate tensile strength of the steel. Permanent force and stress are the force and stress remaining in the tendon after all losses, including creep, shrinkage, and elastic shortening of the concrete; relaxation of the steel; and losses due to sequence of stressing, friction and take-up of anchorages.

For stressing and staged loading of post-tensioned structural elements, verify that concrete strength requirements on the plans are met by testing in accordance with Article 420.4, "Construction," for cast-in-place construction and by testing in accordance with Tex-704-I for precast construction.

Provide suitable means for measuring the elongation of the steel to the nearest 1/16 in. Elongations for determining tendon acceptance must be made before anchor seating and must compensate for:

- dead end anchor loss,
- anchor set, and
- elongation of strand in the jack.

For the required jacking force, the measured elongation must agree within 5% of the calculated elongation. In the event of discrepancies, suspend stressing operations until the problem has been identified and corrected.

Check actual anchor set for agreement with the anticipated value used in the stress calculations. Adjustments to the jacking force may be required to compensate for anchor set greater than anticipated.

Failure of individual wires of a 7-wire strand or of wires in a parallel-wire tendon is acceptable provided the total number of wire failures is not more than 2% of the total number of wires in the tendon group. Failure of an entire strand will be cause for rejection of the tendon. Slippage of anchor wedges will be cause for a structural review for tendon acceptance.

After the tendons have been stressed and the elongations have been approved, immediately cut off the tendon strand tails using an abrasive saw or equal. Do not flame-cut strands. Install the permanent grout cap and close all vent tubes to prohibit moisture accumulation inside the ungrouted duct. Keep grout caps in place until the tendons are grouted.

3. **Duct Connection Pressure Field Test.** Test external tendons with compressed air before grouting to determine if duct connections require repair. Pressurize each tendon to 100 psi and lock off the outside air source. Hold this pressure for at least 5 min. If there is a pressure loss exceeding 10 psi, repair the leaking duct connections according to the approved grouting plan and retest before grouting.
- E. Grouting.** Provide ASBI-certified grouting personnel at the project site during all grouting operations. At least 1 week before starting grouting operations, make a trial batch using the same materials, equipment, and personnel to be used for the actual grouting operations to verify that all equipment is properly operating. Perform this trial batch in the presence of the grout manufacturer's technical representative. Field-test the grout produced for the trial batch in accordance with Table 1. For actual grouting operations, correct problems encountered during trial batching.

Table 1
Requirements for Field Testing of Grout

Test	Frequency	Requirement
Bleed test (Tex-441-A)	1 per day	per DMS-4670
Fluidity test (Tex-437-A, Method 2)	1 every 2 hr. 2 min. per day	per DMS-4670
Strength test (Tex-442-A)	1 per day	per DMS-4670

Unless otherwise noted, grout within 14 days of tendon stressing. Immediately before grouting, remove the grout cap, coat the inside surfaces of the cap with grease, then re-install.

Do not allow the grout temperature to be above 90°F during mixing and pumping. Do not grout when the ambient temperature is less than 35°F.

426.4 to 426.4

Field test the grout in accordance with Table 1 during grout installation. Perform field testing by trained personnel at the Contractor's expense while witnessed by the Engineer.

Add water to the mixer first, followed by the prepackaged grout. Mix the grout according to the manufacturer's recommendations and following the procedures outlined in the grouting plan and used for the trial batch. Mix long enough to obtain a uniform, thoroughly blended grout, without excessive temperature increase or loss of properties of the mixture. Continuously agitate the grout until it is pumped. Do not add water after mixing to increase the flowability of grout. Pump grout within 30 min. of the first addition of the mix components. Keep the hopper at least partially full of grout to prevent air from being drawn into the ducts.

Open all grout vents before grouting. Allow grout to flow from the first vent. Do not close this vent until all visible slugs of grout and air have been ejected and the consistency of the grout flowing from the vent is equivalent to the injected grout. Close all other outlets in the same manner, one after another in the direction of flow except at intermediate crests. Close outlets placed a short distance past the crest before closing the crest outlet. Provide pumping pressure at the inlet no higher than:

- 150 psi for internal plastic ducts and
- 250 psi for internal steel pipe ducts.

For tendons not embedded in concrete, provide pumping pressure no higher than 150 psi. Grout typically at 75 psi pressure for normal grouting operations. If the grouting pressure exceeds the maximum allowed, close the inlet and inject grout at the next vent, which now becomes the inlet, if one-way flow of the grout is maintained. Do not inject grout into a succeeding outlet or vent if grout has not yet flowed from it. When blockage occurs where one-way flow of the grout cannot be maintained, follow the procedures for handling blockages in the approved grouting plan. Do not flush a blocked tendon with water.

To ensure that the duct remains filled with grout, close the outlet first and then the inlet after holding the pressure for 1 min. The inlet must then be sealed off under pressure. Do not open or remove valves, caps, or pipes at the inlet and outlets until the grout has set. Do not subject filled ducts to shock or movement within 24 hr. after grouting.

Investigate the ducts for voids between 24 hr. and 7 days after grouting completion. Remove grout caps in the presence of the Engineer to determine if the cap was completely filled with grout. Inspect inlet and

outlet ports for voids. Completely fill any observed voids with grout by secondary grouting of the duct with a vacuum-grouting process that determines the size of the void and the measure of filling the void with grout. Perform this process according to the approved grouting plan.

Clean exposed end anchorages and other metal accessories of rust, misplaced mortar, grout, and other materials shortly after all post-grouting inspections. Install tight-fitting forms around the anchor assembly immediately after this cleaning and hold it securely in place. Apply a heavy, unbroken coating of epoxy conforming to DMS-6100, "Epoxy and Adhesives," Type V or VII, along the entire surface to be covered by the pourback concrete. Place the pourback concrete with an approved chloride-free non-shrink grout mix while the epoxy is still tacky.

- F. Pretensioning.** Pretension all strands to a uniform initial load between 5% and 25% of the final load. Apply the load within a tolerance of:
- ± 100 lb. per strand if the designated initial load is less than or equal to 10% of the final load or
 - ± 200 lb. per strand if the designated initial load is greater than 10% of the final load.

Measure the initial load with a calibrated dynamometer or other suitable equipment.

Do not allow the modulus of elasticity of individual strands to vary more than 1% from each other when multiple-strand tensioned. Use a weighted average modulus of elasticity of strands to calculate elongation for multiple-strand tensioning operations.

After initial tensioning, establish reference marks on the strand for measuring elongation. Provide means for measuring the elongation of the strand to an accuracy of 1% of the theoretical elongation or 1/8 in., whichever is smaller. Establish independent references on the strand adjacent to each anchorage, to indicate slippage that may occur between the time of initial stressing and final release of the strands.

Do not allow the stress in the strand to exceed 80% of the specified ultimate tensile strength of the strand at any time.

Do not use any portion of the strand that has been previously gripped with chucks in the length of strand to be tensioned.

Strand chucks designed with spring caps must be used with the spring caps. Visually inspect strand chucks that are not equipped with spring caps to ensure that all wedges are evenly seated after applying initial

load. Correct unevenly seated wedges by releasing the stress, repositioning wedges, and reapplying the initial load.

1. **Strand Splicing.** Do not splice draped strands. One splice per straight strand will be permitted subject to the following:
 - Locate splices outside the members.
 - Splice strands with the lay or twist in the same direction to avoid unraveling.
 - Splice all straight strands in a multiple-strand tensioning operation so that an adjustment can be made for the average seating loss.
 - Cut strand ends to be spliced with shears, abrasive saws, or grinders to remove regions where chucks were previously seated. Cut in the same manner at least 12 in. from strand ends to be spliced that were previously flame cut.

2. **Single and Multiple Straight Strand Tensioning.** After initial tensioning, apply the required load to the strands as shown on the plans by means of single-strand or multiple-strand hydraulic jacks equipped with calibrated gauges. Verify the final load in the strands by observing either the gauge pressure or elongation and independently checking the other. The final load and elongation must agree within 5% of the computed theoretical values. Additionally, the final load and elongation must agree algebraically with each other within 5%. In the event of discrepancies greater than these tolerances, suspend tensioning operations until the problem has been identified and corrected.

Verify uniform application of load to strands for multiple-strand-tensioning systems by measuring the movement on opposite sides of the anchorage.

3. **Draped Strand Tensioning.** When draped strands are tensioned in a straight or partially draped position before application of final load, verify the intermediate load by observing either the gauge pressure or elongation and independently checking the other. The intermediate load and elongation must agree within 5% of the computed theoretical values. Additionally, the intermediate load and elongation must agree algebraically with each other within 5%. In the event of discrepancies greater than these tolerances, suspend tensioning operations until the problem has been determined and corrected.

After application of final load, measurements on individual draped strands to establish differential stresses at selected points on the

member will be averaged at a cross-section of the member, and the averages must be within 5% of the theoretical elongation. The measured elongation of any individual draped strand must not vary from the theoretical elongation by more than 10% at any measured cross-section. In the event of discrepancies greater than these tolerances, suspend tensioning operations until the problem has been identified and corrected.

Other methods to measure the intermediate load and final load in the draped strands may be submitted for approval.

4. **Strand Debonding.** When shown on the plans, encase strands in plastic sheathing along the entire debonded length, and seal the ends with waterproof tape. Split plastic sheathing may be used provided the seam is sufficiently sealed with waterproof tape to prohibit grout infiltration. Do not use sheathing that will permanently alter the physical or chemical properties of the surrounding concrete.

Full-length debonding of straight strands will be approved on an individual basis. Full-length debonding, when permitted, must be symmetrical about the vertical centerline of the beam and limited to 10% of the total number of straight strands or 6 straight strands, whichever is less. Do not debond draped strands full length.

5. **Detensioning.** After concrete strength requirements are met, release the tension in the strands using a sequence to minimize premature wire breakage and shock and damage to the concrete members. Release strands by multiple-strand detensioning or single-strand flame detensioning. Do not release strands individually with single-strand jacks.

If strands are released individually, flame-release each strand simultaneously at both ends of the casting bed, using a symmetrical sequence prepared by a licensed professional engineer. When flame detensioning, heat the strands so that the metal gradually loses strength. Include the flame-release sequence on the shop drawings for each strand pattern involved. For products that do not require shop drawings, submit the flame-release sequence for approval. Approval of flame-release sequences does not relieve the Contractor from responsibility for meeting the product workmanship requirements of Section 424.3.C, "Workmanship."

When draped strands are used, release the tension in the strand hold-down anchor slowly to minimize shock and damage to the

426.5 to 426.6

concrete member. If heat is used to release the hold-down anchor, heat the anchor until the metal gradually loses strength. Provide positive external hold-downs to offset the vertical forces in the members when the sum of the hold-down forces is greater than half the weight of the member.

G. Combined Pretensioning and Post-Tensioning. When the plans call for a combination of pretensioning and post-tensioning, all of the requirements for both pretensioning and post-tensioning apply.

426.5. Measurement. Where indicated on the plans, the post-tensioning system for cast-in-place structural units required and the work involved in prestressing cast-in-place structures will be measured by the product of the required final prestress force and the horizontal length over which the prestressing is applied, expressed in thousands of kip-feet (MKF). Unless otherwise shown on the plans, the required final prestress force used will be the maximum value required within a unit, and the length of prestressing will be taken as the overall dimensions of the unit. No deductions will be made for the clearance distance between the ends of tendons and the ends of the unit.

The post-tensioning system for cast-in-place structural units is a plans quantity measurement item. The quantity to be paid is the quantity shown in the proposal unless modified by Article 9.2, "Plans Quantity Measurement." Additional measurements or calculations will be made if adjustments of quantities are required. The maximum percent variance from the plans quantity for which no adjustment will be made will be as shown in Table 2.

Table 2
Percent Variance

Plans Quantity	Percent
> 5,000 MKF	1/2
1,000 MKF–5,000 MKF	1
< 1,000 MKF	1-1/2

426.6. Payment. The work performed and materials furnished in accordance with this Item and measured as provided under "Measurement" will be paid for at the unit price bid for "Post-Tensioning (Grouted)" or "Post-Tensioning (Ungouted)." This price is full compensation for prestressing steel, fabrication, transportation, erection, post-tensioning, encasing ducts, grout fittings, grout, end anchorages, bearing plates, equipment, labor, materials, tools, and incidentals. Materials furnished for testing will not be paid for directly.

Post-tensioning of precast concrete members and all pretensioning will be measured and paid for as specified in Item 425, "Precast Prestressed Concrete Structural Members," unless noted otherwise.

ITEM 427
SURFACE FINISHES FOR CONCRETE

427.1. Description. Finish concrete surface as specified.

427.2. Materials. Furnish materials in accordance with this Article for the type of surface finish specified.

A. Coatings.

1. **Adhesive Grout and Concrete Paint.** Provide coatings in accordance with DMS-8110, "Coatings for Concrete." Match color of coating with Federal Standard 595B color 35630, concrete gray, unless otherwise shown on the plans.
2. **Opaque Sealer.** Provide penetrating-type sealer in accordance with DMS-8110, "Coatings for Concrete." Match color of coating with Federal Standard 595B color 35630, concrete gray, unless otherwise shown on the plans.
3. **742 Appearance Coating.** Provide #742 gray appearance coating (Federal Standard 595B color 35630) in accordance with DMS-8100, "Structural Steel Paints-Formula."
4. **Epoxy Paint.** Provide Type X epoxy coating in accordance with DMS-6100, "Epoxies and Adhesives."

B. Exposed Aggregate Finish. Provide approved aggregates meeting the grading requirements shown on the plans. Unless otherwise shown on the plans, provide gravel consisting of predominantly rounded particles. When a bush-hammered finish is desired, use crushed stone. Provide a concrete surface retardant. Provide clear acrylic resin sealer in accordance with DMS-8110, "Coatings for Concrete," or clear Type II permanent anti-graffiti coating in accordance with DMS-8111, "Anti-Graffiti Coatings."

427.3. Equipment. The Engineer may require demonstration of the equipment's capabilities.

A. Low-Pressure Water Blasting. Use equipment capable of supplying a minimum pressure at the nozzle end of 3,000 psi at a minimum flow rate of 3 gpm. Use a 0° rotary, vibratory, or wobble-type nozzle. Use

427.4 to 427.4

equipment capable of including abrasives in the water stream when specified on the plans.

- B. Abrasive Blasting.** Use equipment equipped with filters to produce oil-free air and also water-free air when dry air is required.
- C. Slurry Blasting.** Use equipment capable of combining air and abrasives with water to form a wet blast media capable of cleaning and preparing surface without creating dust.
- D. Spraying.** For spray applications, use equipment with fluid and air pressure regulators and gauges to allow for adjustment to produce a uniform spray pattern.
- E. Off-the-Form Finish Forms.** Use nonstaining, nonporous, high-quality forming materials (e.g., steel or medium-density and high-density overlaid plywood forms). Use steel or high-density overlaid plywood forms when the same form will be used more than twice.
- F. Form Liners.** Provide form liners capable of producing a patterned finish as shown on the plans. Use form liners that provide a clean release from the concrete surface without pulling or breaking the textured concrete.

427.4. Construction. Provide the finish specified on the plans for the specific surface areas.

- A. Surface Areas of Finish.** “Surface area of finish” designates the areas where the specified surface is to be applied.
 - 1. Surface Area I.** Surface Area I includes:
 - surfaces of railing;
 - exterior vertical faces of fascia beams, slabs, slab spans, arches, and box girders;
 - the outside bottom surface of fascia beams and girders;
 - the underside of overhanging slabs to the point of juncture of the supporting beam;
 - the entire underside of slab spans when shown on the plans;
 - vertical and underside surfaces of bents and piers;
 - all surfaces of tie beams, abutments, bridge wingwalls, culvert headwalls and wingwalls and retaining walls exposed to view after all backfill and embankment is placed; and
 - all other exposed surfaces shown in the plans to require surface treatment.
 - 2. Surface Area II.** Surface Area II includes surfaces of railing, all wingwalls, and the exterior vertical faces of slabs.

3. **Surface Area III.** Surface Area III includes only the top and roadway faces of all concrete railing and bridge wingwalls.
 4. **Surface Area IV.** Surface Area IV includes areas designated on the plans.
- B. Surface Finishes.** Apply the coating or special finish from Table 1 as specified on the plans.

Table 1
Surface Finishes

Coatings	Special Surface Finishes
Adhesive grout	Blast
Concrete paint	Rub
Opaque sealer	Off-the-form
742 appearance coating	Form liner
Epoxy paint	Exposed aggregate

1. Application of Coatings.

- a. **Preparation.** Before applying a coating, thoroughly clean the surface by chemical cleaning, if required, and by blast cleaning.
 - (1) **Chemical Cleaning.** Clean surfaces contaminated with oil, grease, or other contaminants by scrubbing the area with an approved detergent or other concrete cleaning material before blast cleaning. Do not use a solvent that will stain the surface or inhibit coating adhesion. Perform the following test to check for surface contamination of oil type materials:
 - Spray the surface with a fine mist of potable water.
 - Examine the area to see if water beads up.
 - If beading is found, clean the surface.
 - (2) **Blast Cleaning.** Before applying a specified coating, blast-clean the designated surface to remove weak surface material, curing compound, and other contaminants, leaving a lightly etched uniformly textured surface. Use an approved abrasive propelled by oil-free air with or without the addition of potable water, or blast with potable water with or without the addition of an approved abrasive at sufficient pressure to effectively clean and prepare the surface. When water-blasting, maintain the

stand-off-distance of the nozzle to a maximum of 12 in. from the surface being cleaned.

Do not damage concrete surface by gouging, spalling, or exposing coarse aggregate by the blasting operation.

Immediately before application of any coating, blow clean oil- and moisture-free air on all surfaces with sufficient pressure to remove loose particles. Perform the following test to check for surface cleanliness as directed:

- Press a 10 in. long strip of 2 in. wide clear packing tape on the surface by rubbing with moderate pressure times.
- Grasp the free end of the tape, and remove the tape from the surface with a sharp jerk.
- Examine the surface of the tape for clinging particles.

Continue cleaning the concrete surface until there are no particles clinging to the tape surface for subsequent tests. An additional test that can be used to check the surface for dust is to wipe the surface with a dark cloth and then examine the cloth for discoloration.

- b. Application.** Mix coating materials thoroughly with a mechanical mixer at a speed that causes the mixture to rotate entirely in the container. Ensure complete mixing by probing the container with a stirring device searching for non-dispersed or settled material.

Do not apply coatings before the new concrete aging a minimum of 28 days unless approved otherwise. Do not apply coatings when weather conditions will be detrimental to the final surface finish as determined by the Engineer. Do not apply coatings when surface temperature of the concrete exceeds 110°F.

Apply coatings to obtain a consistent color and texture.

- (1) **Adhesive Grout.** Apply coating on a moistened surface to a uniform minimum thickness of 1/16 in. Do not apply when ambient temperature is less than 50°F.
- (2) **Concrete Paint.** Apply the coating on a dry surface in 2 coats for a total maximum application rate of 150 sq. ft. per gallon. Match the color of the applied coating with the color standard shown on the plans. Do not thin material

unless approved. Apply when ambient temperature is between 50°F and 100°F.

- (3) **Opaque Sealer.** Apply the coating to a dry surface in 2 coats for a total maximum application rate of 200 sq. ft. per gallon. Match the color of the applied coating with the approved color standard shown on the plans. Do not thin the material unless approved. Apply when ambient temperature is between 40°F and 95°F.
- (4) **742 Appearance Coating.** Apply the coating on a dry surface at a rate of at most 400 sq. ft. per gallon. Apply when ambient temperature is above 40°F.
- (5) **Epoxy Paint.** Apply the coating on a dry surface at a maximum application rate of 100 sq. ft. per gallon. Apply when ambient temperature is above 50°F.

Repair surface finish where coating has been applied that exhibits peeling, flaking, or discoloration or that has been damaged during construction. Remove defective or damaged coating. Clean and recoat repair area in accordance with the requirements of this Item.

- 2. **Special Surface Finishes.** Submit a work plan to the Engineer for any special finish shown on the plans. Include in the work plan the type of aggregates, materials, variation of panel or pattern arrangement, dimensions, construction methods, and other features affecting the work as is necessary for the “Special Surface Finish” specified.
 - a. **Blast Finish.** Provide surface profile as shown in the plans, or meet the minimum requirements of Section 427.4.B.1.a, “Preparation.” Construct a 4-ft. by 4-ft. sample panel using the same concrete used in construction of the member to receive the blast finish. Prepare the surface of the sample panel to meet the specified finish, and obtain approval of the sample finish. Use the approved sample panel finish as the standard for surfaces requiring a blast finish.
 - b. **Rub Finish.** Provide a finish to the surface by rubbing the surface with a carborundum stone or other approved material. Begin rubbing the surface immediately after forms have been removed. If rubbing surface is delayed to the point where the surface is dry and unable to be rubbed to produce an acceptable finish, provide blast finish or other finish as directed at no additional cost to the Department. Perform the

requirements to obtain the ordinary surface finish specified in Section 420.4.M, “Ordinary Surface Finish,” concurrently with rubbing the surface. Where concrete patching is performed, rub these areas after the patch material has thoroughly set and blend the patch in with the surrounding area to produce a surface with uniform color and texture.

After form removal, keep the surface continuously wet until the rubbing is complete. Rub the surface sufficiently to bring the wetted concrete surface to a paste producing a smooth dense surface without pits, form marks, or other irregularities. Do not use cement grout to form the paste on the surface. Stripe the surface with a brush to conceal the rubbing pattern and allow the paste to reset. Wash the concrete with potable water after the paste has sufficiently set to leave it with a neat and uniform appearance and texture. If required, apply membrane curing in accordance with Item 420, “Concrete Structures,” after rubbing is complete.

- c. **Off-the-Form Finish.** Provide a finish with minimal surface defects and uniform color and texture by using non-staining, non-porous, high-quality forming materials. Use the same type of forming materials for like elements for the entire structure.

Use mortar-tight forms to prevent leakage and discoloration. If necessary, seal joints with compressible gasket material, caulk, tape or by other suitable means that are not detrimental to the concrete finish. Use one brand and type of form release agents for all surfaces unless another product produces a similar concrete surface appearance. Do not use barrier-type (wax, fuel oil, carrier oil, etc.) release agents. Use form release agents containing a rust inhibitor on steel forms. Clean rust off steel forms before use. Do not use plywood that will cause discoloration of the concrete surface.

Direct special attention to consolidation and vibration of the concrete around the form surfaces to minimize bug holes. Modify concrete placement and vibration techniques if surface contains an excessive amount of bug holes. Remove all forms without interruption once form removal begins to prevent discoloration due to differing form curing times.

Do not use membrane curing on surfaces with off-the-form finish.

Repair honeycombed and spall areas with least dimension larger than 2 in. in accordance with the concrete surface repair procedures outlined in Item 420, "Concrete Structures," to obtain an ordinary surface finish as defined in Section 420.4.M, "Ordinary Surface Finish." For honeycombed and spall areas with least dimension greater than 3/4 in. but smaller than 2 in., patch by filling defect with repair material omitting the chipping operation. Do not patch honeycombed and spall areas with least dimension smaller than 3/4 in. Perform required repairs as soon as forms are removed. Match repair material color and texture with surrounding concrete surfaces. Minimize the area of repair by not smearing the repair material over acceptable concrete surfaces in an attempt to blend the repair with the surrounding concrete. Cut out form ties at least 1/2 in. below the surface, and patch accordingly. Perform repair work as soon as possible after removing forms so that concrete and repair material have similar ages. Replace or refurbish the forms when the Engineer determines that defective formwork is causing an excessive amount of repair work.

- d. Form Liner Finish.** Provide patterned finish as shown on the plans. Do not splice form liner panels in a way that causes a noticeable transition or line between pieces. Wash and clean form liners after each use when the forms can be re-used. Replace form liners that have become damaged or worn.

Construct a sample panel for each form liner finish. Approval is required to verify that the sample panel meets the requirements of the plans and specifications before beginning work. Upon approval, the sample panel becomes the model panel that all other work will be compared against. Deviation in color, grade, or depth from the model panel is grounds for rejection of the form liner finish. Removal of defective work may be necessary as determined by the Engineer and in accordance with the surface finish requirements outlined in Item 420, "Concrete Structures," to obtain an ordinary surface finish as defined in Section 420.4.M, "Ordinary Surface Finish."

Seal all form liner joints in a manner acceptable to the Engineer to prevent leakage at the surface.

427.5 to 427.6

- e. **Exposed Aggregate Finish.** Provide exposed aggregate finish as indicated on the plans. Provide a depth of finish between 3/8 in. and 1/2 in. unless directed otherwise.

Apply a concrete surface retarder that penetrates approximately 1/4 in. into the forms or concrete surface to help achieve the desired finish. Apply 2 or 3 coats to wood forms to account for absorption if necessary. Tape or caulk form joints to prevent escape of the retarder during the placing operations. Protect the form surfaces from sun and rain while exposed to the atmosphere. Re-treat form surfaces with retarder if disturbed. Protect adjacent areas of concrete not requiring exposed aggregate finish from the retarder.

Remove forms 12 to 15 hr. after concrete placement but not before concrete has gained sufficient strength to support the self-weight of the member unless directed otherwise. Expose the aggregate for the finish immediately after form removal. Remove the grout paste covering the aggregate to be exposed by an approved method. Do not loosen the aggregate by the grout removal operation. Maintain required curing on all surfaces except for the time while the aggregate is being exposed. Cure using wet mats or membrane after the aggregate is exposed.

Repair defective areas as determined by the Engineer.

Re-clean exposed aggregate surfaces by an approved method. Apply a coat of acrylic resin sealer or clear Type II permanent anti-graffiti coating to cleaned exposed aggregate surface. Apply a single coat or multiple coats for a total maximum application rate of 250 sq. ft. per gallon.

427.5. Measurement. When surface finishes for concrete is shown on the plans to be a pay item, measurement will be by the square foot of the type of surface finish specified.

This is a plans quantity measurement Item. The quantity to be paid is the quantity shown in the proposal, unless modified by Article 9.2, "Plans Quantity Measurement." Additional measurement or calculations will be made if adjustments of quantities are required.

427.6. Payment. Unless otherwise specified on the plans, the work performed, materials furnished, equipment, labor, tools, and incidentals will not be paid for directly, but will be considered subsidiary to pertinent Items.

When a surface finish for concrete is specified as a pay item, the work performed and materials furnished in accordance with this Item and measured as provided under "Measurement" will be paid for at the unit price bid for "Adhesive Grout Finish," "Concrete Paint Finish," "Opaque Sealer Finish," "742 Appearance Coating Finish," "Epoxy Paint Finish," "Blast Finish," or "Rub Finish." This price is full compensation for materials; cleaning and preparing surfaces; application of materials; and equipment, labor, tools, and incidentals.

Off-the-form, form liner, or exposed aggregate finishes (including anti-graffiti coating) will not be paid for under this Item but are subsidiary to other pertinent Items.

ITEM 428

CONCRETE SURFACE TREATMENT

428.1. Description. Prepare surface and apply a linseed oil treatment or a penetrating-type sealant treatment to concrete surfaces.

428.2. Materials. Furnish materials required by the class of surface treatment shown on the plans.

- A. Surface Treatment Class I.** Provide mixture containing a minimum of 50% and a maximum of 70% boiled linseed oil by volume. Use mineral spirits as the complement component for any ambient temperature range above 40°F, or kerosene for ambient temperature range above 70°F. Provide material in accordance with the following specifications:
- Boiled linseed oil: ASTM D 260
 - Mineral spirits: ASTM D 235
 - Kerosene: ASTM D 3699.

Provide combined mixture in clean, leakproof, labeled containers. Clearly state the contents on all the containers.

- B. Surface Treatment Class II.** Provide penetrating surface treatment in accordance with DMS-8140, "Concrete Surface Treatment (Penetrating)."

428.3. Construction Methods. Treat the upper surfaces of the roadway slab (including direct traffic culverts), bridge sidewalks and medians, the inside faces of curbs and concrete rails, and all other areas shown in the plans. Do not treat surfaces given a higher finish as defined in Item 427, "Surface Finishes for Concrete," unless otherwise shown on the plans.

428.3 to 428.3

- A. Surface Treatment Class I.** Clean concrete surfaces to remove contaminants that retard or prevent absorption of the mixture before treatment application. Do not apply the treatment before required concrete curing is complete, while the surface is damp, or when the ambient temperature is below 40°F. Do not heat the mixture. Use a spray applicator equipped with a spray bar to apply the treatment material unless directed otherwise.

Apply the material in 2 stages. Apply at an approximate rate of 40 sq. yd. per gallon for the first stage and 67 sq. yd. per gallon for the second stage for a total coverage of 25 sq. yd. per gallon. Wait a minimum of 4 hr. after the first application before applying the second application. Apply so that a uniform coverage is obtained.

Remove any excess mixture remaining on the surface 4 hr. after the second application or cover with an application of fine sand. Do not allow traffic on the treated surface for 24 hr. after the final application.

- B. Surface Treatment Class II.** Refer to the manufacturer's specifications for instruction on the use of the treatment material in addition to the requirements of this Item.

Clean the concrete surfaces to remove all visible curing compound and any other contaminants that retard or prevent penetration of the mixture before treatment application. Demonstrate the method of cleaning to the Engineer by preparing a 100-sq. ft. area before proceeding with complete cleaning. Do not damage the concrete surface to the point that the coarse aggregate is exposed. Acceptance of the entire cleaned surface by the Engineer is required before the application of the treatment material.

Apply the treatment material no sooner than 14 days after casting the concrete and a minimum of 1 day after curing blankets have been removed.

Apply treatment material to a dry surface no sooner than 24 hours after any water has reached the concrete surface. Apply treatment material when surface temperature is between 40°F and 100°F.

Do not dilute or alter the treatment material.

Apply the treatment material at a rate of 125 sq. ft. of surface area per gallon. Treat the upper side of horizontal and near-horizontal surfaces in 1 pass or coat. Treat the vertical and overhead surfaces in 2 passes or coats. Apply the first coat at a rate of 165 sq. ft. of surface area per gallon, and apply the second coat at a rate of 500 sq. ft. of surface area

per gallon. Apply the second coat within 1 hr. of application of the first coat.

Use a spray applicator equipped with a spray bar to apply the treatment material to deck surfaces.

Apply the treatment material at a uniform rate, covering the entire surface being treated.

Follow the treatment material manufacturer's specifications regarding the post-wetting of the treated surface and required lapse time before traffic is permitted on the treated surface.

428.4. Measurement. This Item will be measured by the square yard of concrete surface treated. This is a plans quantity measurement Item. The quantity to be paid is the quantity shown in the proposal, unless modified by Article 9.2, "Plans Quantity Measurement." Additional measurements or calculations will be made if adjustments of quantities are required.

428.5. Payment. The work performed and materials furnished in accordance with this Item and measured as provided under "Measurement" will be paid for at the unit price for "Concrete Surface Treatment (Class I)" or "Concrete Surface Treatment (Class II)." This price is full compensation for furnishing materials and for equipment, labor, tools, and incidentals.

ITEM 429

CONCRETE STRUCTURE REPAIR

429.1. Description. Remove unsound concrete, repair spalled or delaminated concrete, and replace concrete with repair materials.

429.2. Materials. Provide materials in accordance with the requirements of the following Items:

- Item 420, "Concrete Structures"
- Item 421, "Hydraulic Cement Concrete"
- Item 431, "Pneumatically Placed Concrete"
- Item 440, "Reinforcing Steel"
- DMS-6100, "Epoxies and Adhesives"
- DMS-4655, "Rapid-Hardening Cementing Materials for Concrete Repair."

For all repairs, provide repair materials suitable for the appropriate horizontal, vertical, or overhead application. Obtain approval for any

429.3 to 429.3

proposed repair material unless a repair material type is indicated in the plans.

- A. Repairs Less Than 1 in. Thick.** Use cement mortar; epoxy mortar using a Type VIII epoxy per DMS-6100, “Epoxies and Adhesives”; or a prepackaged repair material meeting the requirements of DMS-4655, “Rapid-Hardening Cementing Materials for Concrete Repair.”
- B. Repairs Between 1 and 6 in. Thick.** Use concrete or a prepackaged repair material meeting the requirements of DMS-4655, “Rapid-Hardening Cementing Materials for Concrete Repair,” containing a coarse aggregate whose maximum size is less than 1/3 the thickness of the thinnest portion of the repair.
- C. Repairs Thicker Than 6 in.** Use concrete of the same class as the original construction unless otherwise approved.

For concrete, submit a mix design for approval in accordance with Item 421, “Hydraulic Cement Concrete,” with a water-cement ratio less than 0.45. Include all pertinent information on admixtures. Prepackaged repair materials not meeting the requirements of DMS-4655, “Rapid-Hardening Cementing Materials for Concrete Repair,” may be used only for with approval. Unless noted otherwise, provide repair materials capable of achieving a 7-day compressive strength of 4,000 psi for repair of reinforced concrete and 5,000 psi for prestressed or post-tensioned concrete members. Pneumatically applied concrete or mortar placed in accordance with Item 431, “Pneumatically Placed Concrete,” may also be used with approval. Prepare trial batches of any proposed repair material or application method as directed.

Provide steel pins, studs, or expansion bolts with a minimum diameter of 1/8 in. and a minimum length of 2 in. to attach reinforcement at the described location as shown on the plans or as directed. Provide reinforcing steel, either welded wire fabric or reinforcing bars, as required by this Item or as shown on the plans.

429.3. Equipment. Provide equipment as outlined below.

- A. Concrete Removal Equipment.** Provide sawing equipment capable of sawing the concrete to the specified depth. Provide power-driven chipping tools not heavier than the nominal 30-lb. class or hydrodemolition equipment for the bulk removal of concrete. Provide chipping hammers not heavier than the nominal 15-lb. class or hydrodemolition equipment for the removal of concrete beneath reinforcing steel or along the edges of the repair area.

- B. Surface Preparation Equipment.** Provide abrasive blasting or hydrodemolition equipment capable of preparing the concrete surface and exposed reinforcing steel for the repair material. Provide air compressors with air lines equipped with filters designed to remove all oil from the air for air-blast cleaning. Provide high-pressure water blasting equipment as necessary to prepare surfaces for repair.
- C. Proportioning and Mixing Equipment.** Provide mixing equipment for concrete in accordance with Item 421, “Hydraulic Cement Concrete.” Provide small motor-driven mixers for small quantities of repair material using the volumetric method of measuring ingredients. Provide mixing equipment as recommended by the manufacturer for prepackaged repair materials.
- D. Placing and Finishing Equipment.** Provide sufficient and appropriate hand tools for placing and finishing stiff plastic concrete or prepackaged repair materials, and for working them to the correct level for strike-off. Provide small, immersion-type vibrators for all repairs deeper than 6 in. Provide external form vibrators where immersion-type vibrators cannot be used.

429.4. Construction. Obtain approval for all materials and methods of application at least 2 weeks before beginning any repair work. Repair locations will be indicated on the plans or by the Engineer. Saw-cut the entire perimeter of all repair areas to a minimum depth of 1/2 in. Avoid re-entrant corners for areas to be repaired. Adjust the depth of the saw-cut as necessary to avoid cutting reinforcing steel near the surface of the concrete.

- A. Removal of Concrete.** Use power-driven chipping tools or hydrodemolition equipment to remove all loose or defective concrete. Avoid damage to sound concrete to remain in place. Avoid hitting reinforcing steel with the chipping tools. Once the initial concrete is removed, use small power-driven chipping or hydrodemolition equipment to undercut all exposed reinforcing steel. Expose the entire perimeter of the steel bars for the full area of the repair. Provide a minimum clearance of 1/2 in. between the exposed steel and the surrounding concrete or 2 times the maximum aggregate size, whichever is greater. Remove additional concrete as necessary to keep the repair area to a reasonably uniform depth. Damage to sound concrete or to the bond of reinforcing steel outside the repair area will be repaired at the Contractor’s expense. Obtain approval of the completed concrete removal before proceeding to surface preparation.

- B. Surface Cleaning.** Clean the area to be repaired by abrasive blasting, high-pressure water blasting, or other approved methods. Remove all loose particles, dirt, deteriorated concrete, or other substances that would impair the bond of the repair material. Clean exposed reinforcing steel of concrete, rust, oil, and other contaminants. Follow this with a high-pressure air blast for final cleaning.
- C. Anchors.** When reinforcing steel is required, support it using anchor studs, expansion hook bolts, grouted rebar, or steel pins capable of resisting a pullout force of 2,500 lb. Space anchors no more than 12 in. center-to-center on overhead surfaces, 18 in. center-to-center on vertical surfaces, and 36 in. center-to-center on top horizontal surfaces. Use at least 3 anchors in each individual patch area. Secure steel pins or studs into the concrete with epoxy or other approved methods. Do not use explosive force to shoot pins, studs, or other anchors into the concrete. Check the resistance to pullout of the reinforcing anchors as directed. Notify the Engineer before installation of the anchors. Locate anchors to prevent damage to prestressing tendons or conduits embedded in the concrete. Maintain a minimum clear cover of 3/4 in. between the reinforcing steel and anchors and the finished surface of the repair area.
- D. Reinforcing Steel.** Replace or supplement any reinforcing steel that has more than 25% section loss due to corrosion. Place supplemental reinforcing steel as indicated on the plans or as directed. Provide additional reinforcement for all areas where the thickness of the repair material will exceed 4 in. Use a single layer of $2 \times 2 - W1.2 \times W1.2$ or $3 \times 3 - W1.5 \times W1.5$ welded wire fabric or No. 3 bars spaced at 6 in., unless noted otherwise on the plans. Place the reinforcing steel parallel to the finished surface, and support it so that it will be roughly in the middle of the repair area and a minimum of 3/4 in. out from the surface to be covered. Lap adjacent sheets or bars at least 6 in. and tie them together securely at a spacing of at most 18 in. Pre-bend reinforcing steel fabric to fit around corners and into re-entrant angles before installing it. Place and secure reinforcement to prevent displacement due to repair material application.
- E. Formwork.** Where forms are necessary or desired, erect them in accordance with Item 420, "Concrete Structures." Ensure forms are securely attached and mortar-tight if pressure-type application methods are used.
- F. Substrate Preparation.** Use a bonding agent if cement mortar or concrete is used for the repair material unless directed otherwise. Use

either a cement scrub coat or a Type V or Type VII epoxy conforming to DMS-6100, "Epoxy and Adhesives," as the bonding agent. Follow the manufacturer's recommendations for bonding agents if prepackaged repair materials are used. Do not use an epoxy bonding agent with rapid setting repair materials. Apply a cement scrub coat bonding agent to the saturated surface-dry substrate by scrubbing, brushing, or other approved methods immediately before placing the repair material. Apply an epoxy bonding agent in accordance with the manufacturer's recommendations. Ensure that any bonding agent used does not set or cure prematurely, creating a bond breaker.

Where saturated surface-dry (SSD) conditions are needed, prewet the substrate by ponding water on the surface for 24 hr. before placing the repair materials. If ponding is not possible, achieve SSD conditions by high-pressure water blasting 15 to 30 min. before placing the repair material. A saturated surface-dry condition is achieved when the surface remains damp when exposed to sunlight for 15 min.

- G. Repair Material Application.** Place the repair material in an approved manner ensuring that the repair material is in intimate contact with the substrate and free of voids. Follow the manufacturer's recommendations for prepackaged repair materials. Place repair materials so that the original lines and surfaces of the structure are restored. Follow the requirements of Item 420, "Concrete Structures," for temperature limitations at time of placement.
- H. Curing.** Cure all cement mortar and concrete repairs for 4 days in accordance with Item 420, "Concrete Structures." Cure prepackaged repair materials in conformance with the manufacturer's recommendations. Cure pneumatically placed concrete in accordance with Item 431, "Pneumatically Placed Concrete." Remove forms when approved or at the end of the curing period.
- I. Epoxy Injection.** Perform epoxy injection as indicated in the plans or as directed, in accordance with Item 780, "Epoxy Injection."
- J. Repair of Defective Work.** As directed, after completion of curing, repair or replace defective areas and patched areas that have debonded, at the Contractor's expense.

429.5. Measurement. This Item will be measured by the square foot, in place, as measured on the surface of the completed repair. When a repair involves multiple surfaces, such as a corner, measurement will be made of all surfaces repaired.

429.6 to 430.3

429.6. Payment. The work performed and materials furnished in accordance with this Item and measured as provided under “Measurement” will be paid for at the unit price bid for “Concrete Structure Repair.” This price is full compensation for furnishing and placing all repair materials; removing all loose and defective concrete; saw-cutting; cleaning reinforcing steel; supplying and installing replacement or supplemental reinforcing steel, drive pins, studs, or expansion bolts; and equipment, labor, and incidentals.

ITEM 430

EXTENDING CONCRETE STRUCTURES

430.1. Description. Prepare and construct extensions and widenings of existing structures.

430.2. Materials. Furnish materials in accordance with the following:

- Item 420, “Concrete Structures”
- Item 421, “Hydraulic Cement Concrete”
- Item 440, “Reinforcing Steel”
- DMS-6310, “Joint Sealants and Fillers.”

430.3. Construction.

- A. General.** Perform work in accordance with Item 420, “Concrete Structures,” and the requirements of this Item. Verify pertinent dimensions and elevations of the existing structure before ordering any required materials.
- B. Removal.** Remove portions of the existing structure to the lines and dimensions shown on the plans or as directed. Dispose of these materials as shown on the plans or as directed. Remove any metal railing without damaging it, and stack it neatly on the right of way at locations that do not interfere with traffic or construction or at locations shown on the plans. All removed metal railing remains the property of the Department unless otherwise shown on the plans. Repair any portion of the remaining structure damaged as a result of the construction.

Do not use explosives to remove portions of the existing structure unless approved in writing. Do not use a demolition ball, other swinging weight, or impact equipment unless shown on the plans. Use pneumatic or hydraulic tools for final removal of concrete at the

“break” line. Use removal equipment, as approved, that will not damage the remaining concrete.

- C. **Reuse of Removed Portions of Structure.** Detach and remove all portions of the old structure that are to be incorporated into the extended structure to the lines and details as specified on the plans or as directed. Move the unit to be reused to the new location specified using approved methods. Place the reinforcement and extension concrete according to the plan details.
- D. **Breaking Back Bridge Slabs.** For bridge slabs and direct traffic slabs of box culverts, saw the top surface of the slab along the “break” line to a depth of 1/2 in. before breaking back. Do not cut the reinforcement at the “break” line. Sever the concrete at the “break” line. Do not damage the remaining reinforcement within 1 lap length of the “break” line during removal of the designated portion of the existing structure.
- E. **Splicing Reinforcing Steel.** Splice new reinforcing bars to exposed bars in the existing structure using lap splices in accordance with Item 440, “Reinforcing Steel,” unless otherwise shown on the plans. The new reinforcing steel does not need to be tied to the existing steel where spacing or elevation does not match that of the existing steel provided the lap length is attained. Weld in accordance with Item 448, “Structural Field Welding,” when welded splices are permitted. Install any required dowels in accordance with Item 420, “Concrete Structures.”
- F. **Concrete Preparation.** Roughen and clean concrete surfaces that are in contact with new construction before the placing of forms. Prepare these construction joint surfaces in accordance with Item 420, “Concrete Structures.”

Finish and cure roadway slabs in accordance with Item 420, “Concrete Structures.”

430.4. Measurement. This Item will be measured by the quantity of concrete as provided under “Measurement” in Item 420, “Concrete Structures.”

430.5. Payment. The work performed and materials furnished in accordance with this Item and measured as provided under “Measurement” will be paid for at the unit price bid for “Concrete for Extending Structures” of the class and various structure elements specified. Payment for this Item will be made under this Item but will be as defined under “Payment” in Item 420, “Concrete Structures,” except as follows.

431.1 to 431.2

In addition to the work described in Item 420, "Concrete Structures," the unit prices bid for the various classifications of concrete shown are full compensation for removing and disposing of, if necessary, the designated portion of the existing structure; removing, stockpiling if necessary, and replacing headwall units for reuse; cleaning, bending, and cutting of exposed reinforcing steel; splicing of new reinforcing steel to existing reinforcing steel; installation of dowels; and cleaning and preparing existing concrete surfaces.

ITEM 431

PNEUMATICALLY PLACED CONCRETE

431.1. Description. Furnish and place pneumatically applied concrete for the construction of portions of structures, repairing concrete structures, encasement of structural steel members, lining ditches and tunnels, soil-nail walls, and other work as shown on the plans or as directed. Pneumatically applied concrete can be either dry-mix or wet-mix. The dry-mix process consists of dry-mixed fine aggregate and hydraulic cement to which water is added immediately before its pneumatic expulsion from a nozzle. The wet-mix process consists of mechanically premixed concrete pneumatically applied through a nozzle.

431.2. Materials. Provide Class I concrete for repairs and Class II concrete for encasement unless otherwise noted. Provide the class of concrete shown on the plans for other work.

With the exceptions noted in Sections 431.2.A, "Exceptions to Item 421, 'Hydraulic Cement Concrete,'" 431.2.B, "Exceptions to Item 440, 'Reinforcing Steel,'" and 431.2.C, "Exception to DMS-6310, 'Joint Sealants and Fillers,'" provide materials in accordance with the pertinent requirements of the following Items:

- Item 420, "Concrete Structures"
- Item 421, "Hydraulic Cement Concrete"
- Item 440, "Reinforcing Steel"
- DMS-6310, "Joint Sealants and Fillers"
- DMS-4640, "Chemical Admixtures for Concrete."

A. Exceptions to Item 421, "Hydraulic Cement Concrete." Provide a fine aggregate that meets the requirements of Item 421, Table 4, Grade 1, and a coarse aggregate that meets the requirements of Item 421, Table 3, Grade 7, unless otherwise noted on the plans.

- B. Exceptions to Item 440, “Reinforcing Steel.”** Provide steel pins, studs, or expansion bolts with a minimum diameter of 1/8 in. and a minimum length of 2 in. to attach reinforcement for the repair of concrete structures as shown on the plans or as directed. Reinforcing steel may be either welded wire fabric or reinforcing bars unless otherwise shown on the plans.
- C. Exception to DMS-6310, “Joint Sealants and Fillers.”** Provide a preformed bituminous fiber material unless otherwise noted on the plans.
- D. Proportioning and Mixing.** Submit for approval a proposed mix design conforming to the basic mix design requirements provided in Table 1.

Table 1
Classes of Concrete

Class	Ratio of Cement to Total Aggregate ¹	Minimum 7-Day Compressive Strength (psi)
I	1:4	3,000
II	1:5	2,500
III	1:7	1,700

1. More cement may be used when approved.

Measure the cement and aggregates by volume, and mix with enough water to achieve the desired consistency. Use as little water as possible to achieve sufficient adhesion. Mix concrete sufficiently dry so that it will not sag or fall from vertical or inclined surfaces, or separate in horizontal work.

To verify the mix design before approval, prepare test panels using the same air pressure, nozzle tip, and position to be used for the production work. For each test panel, apply a 3-in. layer of concrete to a plywood sheet with minimum dimensions of 18 in. × 18 in. Cure the test panels in the same manner as the proposed work.

Take three cores, each 2 in. in diameter, out of each test panel and test in compression at seven days in accordance with Tex-424-A. The mix design will be approved when the average strength of the three cores conforms to the strengths shown in Table 1. Provide additional test panels as directed if there are any changes in materials, equipment, or nozzle operator during the work.

431.3 to 431.3

431.3. Construction.

- A. Surface Preparation.** When concrete is to be placed against soil, grade the area of proposed work accurately to the elevation and dimensions shown on the plans. Compact with sufficient moisture to provide a firm foundation and to prevent absorption of water from the concrete, but without free surface moisture.

When concrete is used to encase structural steel members, remove paint, rust, loose mill scale, grease or oil, and all other foreign materials that may reduce the bond of the concrete to the steel.

When concrete is placed against concrete or rock, remove all deteriorated or loose material by chipping with pneumatic, electric, or hand tools. Cut square or slightly undercut shoulders approximately 1 in. deep along the perimeter of repair areas. Sandblast the surface to clean all rust from exposed reinforcing steel and to produce a clean rough-textured surface on the concrete or rock. Wet the surface against which the concrete will be placed for at least 1 hour with potable water. Place the concrete when the surface has dried to a saturated surface-dry (SSD) condition. Achieve SSD conditions by high-pressure water blasting 15 to 30 minutes before placing the repair material. A saturated surface-dry condition is achieved when the surface remains damp when exposed to sunlight for 15 minutes.

Provide joints, side forms, headers, and shooting strips for backing or paneling. Use ground or gauging wires where necessary to establish thickness, surface planes, and finish lines.

- B. Reinforcement.** Place and secure reinforcement to ensure that there is no displacement from impact of applying pneumatically placed concrete. Place reinforcing bars at a spacing not less than 2-1/2 in. Support reinforcing wire fabric or bars using anchor studs, expansion hook bolts, grouted rebar, or steel pins capable of resisting a pullout force of 2,500 lb. Space anchors no more than 12 in. center-to-center on overhead surfaces, 18 in. center-to-center on vertical surfaces, and 36 in. center-to-center on top horizontal surfaces. Use at least 3 anchors in each individual patch area. Secure steel pins or studs into the concrete with epoxy or other approved methods. Do not use explosive force to shoot pins, studs, or other anchors into concrete. Check the resistance to pullout of the reinforcing anchors as directed. Notify the Engineer prior to installation of the anchors. Locate anchors so that there is no damage to prestressing tendons or conduits embedded in the concrete.

Use reinforcement when performing repair work in all areas where the thickness of the concrete will exceed 1-1/2 in. Use a single layer of either $2 \times 2 - W1.2 \times W1.2$ or $3 \times 3 - W1.5 \times W1.5$ of welded wire fabric unless noted otherwise on the plans. Use a single layer of wire fabric to reinforce each 4-in. thickness of patch or fractional part in areas where the concrete thickness exceeds 4 in. Encase completely each layer of wire fabric in concrete that has taken its initial set before installing the succeeding layer of wire fabric. Place the reinforcing fabric parallel to the finished surface, and support it so that it will be a minimum of 3/4 in. out from the surface to be covered. Provide a minimum of 1 in. clearance between the finished concrete surface and all steel items including anchors, reinforcing bars, and wire fabric. Lap adjacent sheets at least 6 in. and tie together securely at a spacing of no more than 18 in. Pre-bend fabric before installing to fit around corners and into re-entrant angles.

For encasement of steel members, pre-bend the welded wire fabric using a template to conform as nearly as possible to the outlines of the members to be encased. Drill holes between 1/2 and 1 in. in diameter in the webs of the members as close as possible to the flanges to allow for attachment of the reinforcing fabric. Space these holes at approximately 3 ft. on center. Use 3/8-in. diameter rods placed through these holes to secure the reinforcing fabric. Hold the reinforcing fabric at least 3/4 in. out from the surface of the steel member. Lap adjacent fabric sheets at least 6 in. and tie together at a spacing not to exceed 12 in.

C. Pneumatic Placement of Concrete.

- 1. General.** Place the concrete when the ambient temperature is above 35°F. Do not place concrete against a surface containing frost or ice. Protect concrete from freezing or quick drying after placement. For construction of portions of structures, repairing concrete structures, or encasement of structural steel members, apply the concrete using pneumatic equipment that sprays the mix onto the prepared surface at a velocity less than 100 ft. per second. Minimize rebound and produce a compacted dense homogenous mass. Do not apply concrete if high winds will prevent proper application or if rain could wash out the concrete.

For construction of portions of structures, repairing concrete structures, or encasement of structural steel members, provide documentation that the nozzle operator is certified by the American Concrete Institute for the process (wet-mix or dry-mix) and application (vertical or overhead) to be used. Hold the nozzle

431.3 to 431.3

approximately 2 to 4 ft. from the surface and position it so that the concrete impinges nearly at right angles to the surface being covered. Use shooting strips to ensure straight lines, square corners, and a plane surface of concrete. Place to keep the trapping of rebound to a minimum. Slope the concrete off to a thin edge at the ends of each day's work or at similar stopping periods requiring construction joint. Thoroughly clean and wet previously placed concrete before placing an adjacent or additional section. Apply a sufficient number of coats to obtain the required thickness. Place coats on vertical and overhead surfaces in layers not greater than 1 in. thick. Place so that the coat does not sag or decrease the bond of the preceding coat. Provide a sufficient interval between successive layers in sloping, vertical, or overhead work to allow initial but not final set. Clean the surface to remove the thin film of laitance to provide for a bond with succeeding applications. Remove rebound and accumulated loose sand from the surface to be covered prior to placing of the original or succeeding layers of concrete. Correct any sags or other defects to the proper section as directed.

Apply the concrete using either the wet-mix or dry-mix process unless otherwise noted on the plans. Mix the materials thoroughly and uniformly using a paddle or drum type mixer designed for pneumatic application. Wet-mix process applications can use transit-mix concrete. Do not use the wet-mix process for repair of damaged concrete.

Clean mixing and placing equipment at regular intervals. Inspect the nozzle liner and water and air injection system daily and replace worn parts as necessary.

- 2. Dry-Mix Process.** Use a compressor or blower capable of delivering a sufficient volume of oil-free air at the pressure shown in Table 2. Maintain steady pressure throughout the placing process.

Use a water pump with the size and capacity to deliver water to the nozzle with a pressure at least 15 psi more than the required air pressure.

Table 2
Compressor Capacities

Compressor Capacity, CFM	Hose Diameter, in.	Maximum Size of Nozzle Tip, in.	Operating Air Pressure Available, psi
250	1	3/4	40
315	1-1/4	1	45
365	1-1/2	1-1/4	55
500	1-5/8	1-1/2	65
600	1-3/4	1-5/8	75
750	2	1-3/4	85

The values shown in Table 2 are based on a hose length of 150 ft. with the nozzle less than 25 ft. above the delivery equipment. Increase operating pressure approximately 5 psi for each additional 50 ft. of hose and approximately 5 psi for each 25 ft. the nozzle is raised.

3. **Wet-Mix Process.** Operate the pump at a line pressure between 100 psi and 300 psi. Use delivery hoses between 1-1/2 in. and 3 in. in diameter. Use mixing equipment capable of thoroughly mixing the materials in sufficient quantity to maintain continuous placement.
- D. **Construction Joints.** Use a square butt joint where the joint is subject to compressive stress or is over existing construction joints unless noted otherwise on the plans. Use tapered or square butt joints at other locations. Square the outside 1 in. of tapered joints perpendicular to the surface.
 - E. **Finish.** Use a sharp trowel to cut off all high spots after the concrete has been placed to the desired thickness or screed to a true plane as determined by shooting strips or by the original concrete surface. Lightly apply cutting screeds, where used, to all surfaces so as not to disturb the concrete for an appreciable depth. Work in an upward direction when concrete is applied on vertical surfaces. Give the finished concrete a final flash coat of about 1/8 in. unless directed otherwise. Obtain a uniform appearance on all exposed surfaces.
 - F. **Curing.** Cure encasements with water for 4 days. Cure repairs and structural construction using either a piece of wet burlap taped over the repaired area with a covering of 4-mil minimum plastic sheet also taped in place or membrane curing as approved. Overlap the burlap with the plastic sheet, and continuously tape the edges with a tape at least 3 in.

431.4 to 432.2

wide (air duct tape or better) to completely enclose the mat and hold in moisture. Cure in this manner for 4 days. Curing is not required for soil-nail walls. Apply membrane curing in accordance with Item 420, "Concrete Structures," for tunnel and ditch linings and vertical or overhead patches as approved.

G. Repair of Defects. Repair or replace debonded areas as directed.

431.4. Measurement. Measurement of pneumatically placed concrete for encasement of structural members will be by the square foot of the actual contact area.

Measurement of pneumatically placed concrete for repair of concrete structures will be by the cubic foot in place using the surface area times the average depth of the patch.

431.5. Payment. When pneumatically placed concrete is specified as a bid item, the work performed and materials furnished in accordance with this Item and measured as provided under "Measurement" will be paid for at the unit price bid for "Pneumatically Placed Concrete (Encasement)" or for "Pneumatically Placed Concrete (Repair)." This price is full compensation for cement, aggregate, water, and reinforcement; furnishing and driving steel drive pins; furnishing and placing expansion bolts; removal of deteriorated or unsound concrete; mixing, placing, and curing pneumatically placed concrete; and equipment, labor, tools, and incidentals. Pneumatically placed concrete used for work other than encasement or repair will not be paid for directly but will be considered subsidiary to pertinent Items.

ITEM 432

RIPRAP

432.1. Description. Furnish and place concrete, stone, cement-stabilized, or special riprap.

432.2. Materials. Furnish materials in accordance with the following:

- Item 420, "Concrete Structures"
- Item 421, "Hydraulic Cement Concrete"
- Item 431, "Pneumatically Placed Concrete"
- Item 440, "Reinforcing Steel"
- DMS-6200, "Filter Fabric."

- A. Concrete Riprap.** Use Class B Concrete unless otherwise shown on the plans.
- B. Pneumatically Placed Concrete Riprap.** Use Class II concrete that meets Item 431, “Pneumatically Placed Concrete,” unless otherwise shown.
- C. Stone Riprap.** Unless otherwise shown on the plans, use durable natural stone with a minimum bulk specific gravity of 2.40 as determined by Tex-403-A. Provide stone that, when tested in accordance with Tex-411-A, has a maximum weight loss of 18% after 5 cycles of magnesium sulfate solution and 14% after 5 cycles of sodium sulfate solution.

For all types of stone riprap perform a size verification test on the first 5,000 sq. yd. of finished riprap stone at a location determined by the Engineer. Weigh each stone in a square test area with the length of each side of the square equal to 3 times the specified riprap thickness. The weight of the stones, excluding spalls, should be as specified below. Additional tests may be required. Do not place additional riprap until the initial 5,000 sq. yd. of riprap has been approved.

When specified, provide grout or mortar in accordance with Item 421, “Hydraulic Cement Concrete.” Provide grout with a consistency that will flow into and fill all voids.

Provide filter fabric in accordance with DMS-6200, “Filter Fabric.” For protection stone riprap, provide Type 2 filter fabric unless otherwise shown on the plans. For Type R, F, or Common stone riprap, provide Type 2 filter fabric when shown on the plans.

- 1. Type R.** Use stones between 50 and 250 lb. with a minimum of 50% of the stones heavier than 100 lb.
- 2. Type F.** Use stones between 50 and 250 lb. with a minimum of 40% of the stones heavier than 100 lb. Use stones with at least 1 broad flat surface.
- 3. Common.** Use stones between 50 and 250 lb. Use stones that are at least 3 in. in their least dimension. Use stones that are at least twice as wide as they are thick. When shown on the plans or approved, material may consist of broken concrete removed under the Contract or from other approved sources. Before placement of each piece of broken concrete, cut exposed reinforcement flush with all surfaces.
- 4. Protection.** Use boulders or quarried rock that meets the gradation requirements of Table 1. Both the width and the thickness of each

piece of riprap must be at least 1/3 of the length. When shown on the plans or as approved, material may consist of broken concrete removed under the Contract or from other approved sources.

Before placement of each piece of broken concrete, cut exposed reinforcement flush with all surfaces. Determine gradation of the finished, in-place, riprap stone under the direct supervision of the Engineer in accordance with Tex-411-A, Part II.

**Table 1
In-Place Protection Riprap Gradation Requirements**

Thickness	Maximum Size (lb.)	90% Size¹ (lb.)	50% Size¹ (lb.)	8% Size¹, Minimum (lb.)
12 in.	200	80–180	30–75	3
15 in.	320	170–300	60–165	20
18 in.	530	290–475	105–220	22
21 in.	800	460–720	175–300	25
24 in.	1,000	550–850	200–325	30
30 in.	2,600	1,150–2,250	400–900	40

1. As defined in Tex-401-A, Part II.

Provide bedding stone that in-place meets the gradation requirements shown in Table 2 or as otherwise shown on the plans. Determine size distribution in accordance with Tex-401-A, Part I.

**Table 2
Protection Riprap Bedding Material Gradation Requirements**

Sieve Size (Sq. Mesh)	% by Weight Passing
3 in.	100
1-1/2 in.	50–80
3/4 in.	20–60
No. 4	0–15
No. 10	0–5

- D. Cement-Stabilized Riprap.** Provide aggregate that meets Item 247, “Flexible Base,” for the type and grade shown on plans. Use cement-stabilized riprap with 7% hydraulic cement by dry weight of the aggregate.
- E. Special Riprap.** Furnish materials for special riprap according to the plans.

432.3. Construction. Dress slopes and protected areas to the line and grade shown on the plans before the placement of riprap. Place riprap and toe walls according to details and dimensions shown on the plans or as directed.

- A. Concrete Riprap.** Reinforce concrete riprap with $6 \times 6 - W2.9 \times W2.9$ welded wire fabric or with No. 3 or No. 4 reinforcing bars spaced at a maximum of 18 in. in each direction unless otherwise shown. Alternative styles of welded wire fabric that provide at least 0.058 sq. in. of steel per foot in both directions may be used if approved. A combination of welded wire fabric and reinforcing bars may be provided when both are permitted. Provide a minimum 6-in. lap at all splices. At the edge of the riprap, provide a minimum horizontal cover of 1 in. and a maximum cover of 3 in. Place the first parallel bar at most 6 in. from the edge of concrete. Use approved supports to hold the reinforcement approximately equidistant from the top and bottom surface of the slab. Adjust reinforcement during concrete placement to maintain correct position.

As directed, sprinkle or sprinkle and consolidate the subgrade before the concrete is placed. All surfaces must be moist when concrete is placed.

After placing the concrete, compact and shape it to conform to the dimensions shown on plans. After it has set sufficiently to avoid slumping, finish the surface with a wood float to secure a smooth surface or broom finish as approved.

Immediately after the finishing operation, cure the riprap according to Item 420, "Concrete Structures."

- B. Stone Riprap.** Provide the following types of stone riprap when shown on the plans:

- **Dry Riprap.** Dry riprap is stone riprap with voids filled with only spalls or small stones.
- **Grouted Riprap.** Grouted riprap is Type R, F, or Common stone riprap with voids grouted after all the stones are in place.
- **Mortared Riprap.** Mortared riprap is Type F stone riprap laid and mortared as each stone is placed.

Use spalls and small stones lighter than 25 lb. to fill open joints and voids in stone riprap, and place to a tight fit.

Do not place mortar or grout when the air temperature is below 35°F. Protect work from rapid drying for at least 3 days after placement.

Unless otherwise approved, place filter fabric with the length running up and down the slope. Ensure fabric has a minimum overlap of 2 ft.

432.3 to 432.3

Secure fabric with nails or pins. Use nails at least 2 in. long with washers or U-shaped pins with legs at least 9 in. long. Space nails or pins at a maximum of 10 ft. in each direction and 5 ft. along the seams. Alternative anchorage and spacing may be used when approved.

1. **Type R.** Construct riprap as shown in Figure 1 and as shown on the plans. Place stones in a single layer with close joints so that most of their weight is carried by the earth and not by the adjacent stones. Place the upright axis of the stones at an angle of approximately 90° to the embankment slope. Place each course from the bottom of the embankment upward with the larger stones in the lower courses.

Fill open joints between stones with spalls. Place stones to create a uniform finished top surface. Do not exceed a 6-in. variation between the tops of adjacent stones. Replace, embed deeper, or chip away stones that project more than the allowable amount above the finished surface.

When the plans require Type R stone riprap to be grouted, prevent earth, sand, or foreign material from filling the spaces between the stones. After the stones are in place, wet the stones thoroughly, fill the spaces between the stones with grout, and pack. Sweep the surface of the riprap with a stiff broom after grouting.

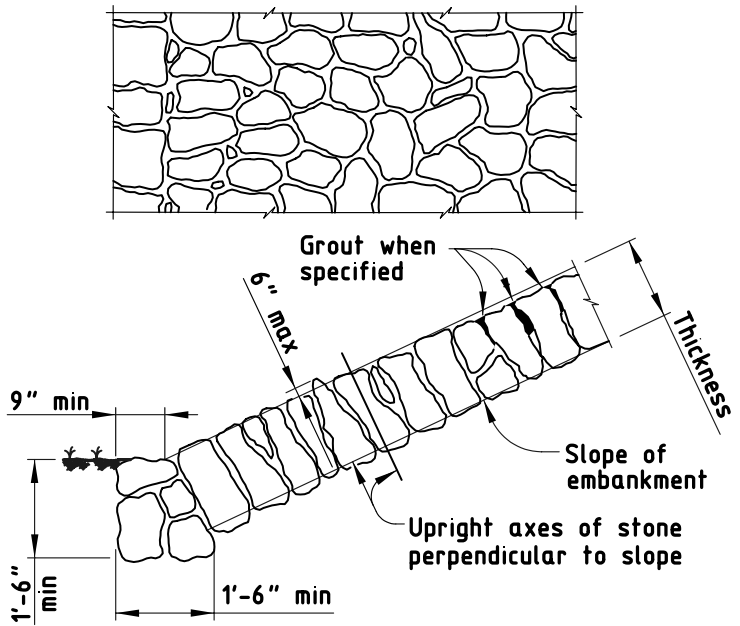

Figure 1
Type R stone riprap, dry or grouted.

2. Type F.

- a. **Dry Placement.** Construct riprap as shown in Figure 2. Set the flat surface on a prepared horizontal earth bed, and overlap the underlying course to secure a lapped surface. Place the large stones first, roughly arranged in close contact. Fill the spaces between the large stones with suitably sized stones placed to leave the surface evenly stepped and conforming to the contour required. Place stone to drain water down the face of the slope.

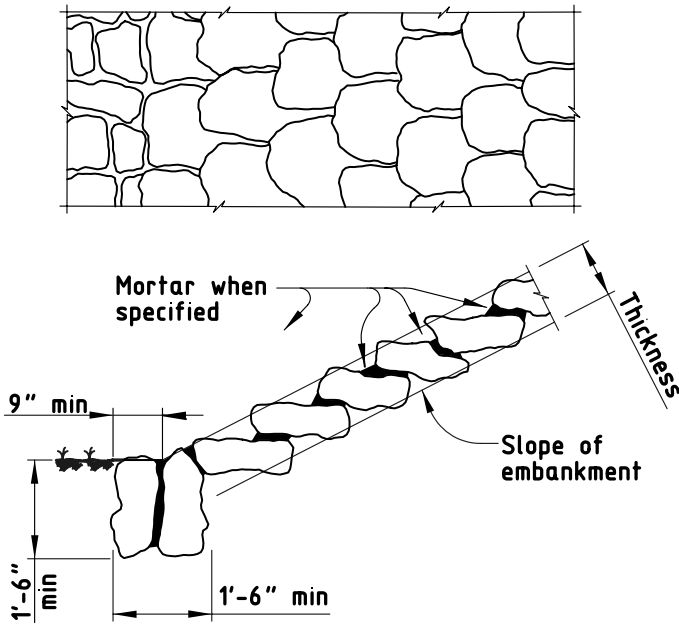

Figure 2
Type F stone riprap, dry or mortared.

- b. **Grouting.** Construct riprap as shown in Figure 3. Size, shape, and lay large flat-surfaced stones to produce an even surface with minimal voids. Place stones with the flat surface facing upward parallel to the slope. Place the largest stones near the base of the slope. Fill spaces between the larger stones with stones of suitable size, leaving the surface smooth, tight, and conforming to the contour required. Place the stones to create a plane surface with a maximum variation of 6 in. in 10 ft. from true plane. Provide the same degree of accuracy for warped and curved surfaces. Prevent earth, sand or foreign material from filling the spaces between the stones. After the stones are in place, wet them thoroughly, fill the spaces between them with grout, and pack. Sweep the surface with a stiff broom after grouting.

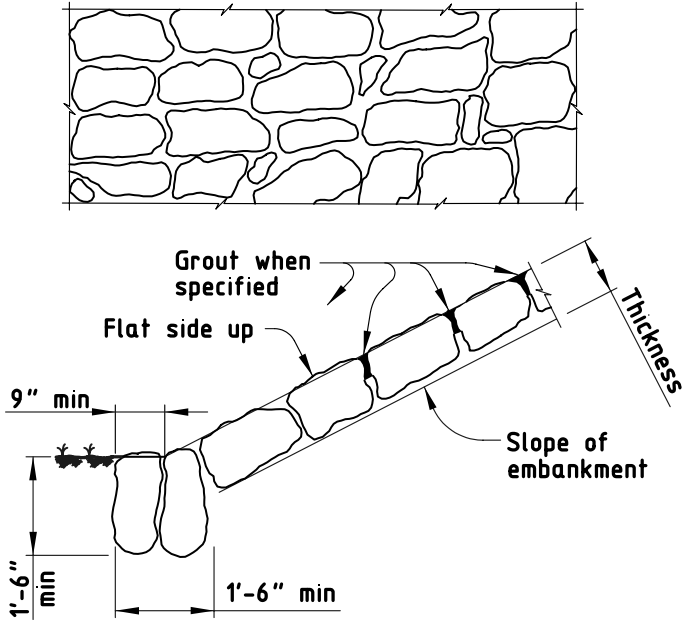

Figure 3
Type F stone riprap, grouted.

- c. **Mortaring.** Construct riprap as shown in Figure 2. Lap courses as described for dry placement. Before placing mortar, wet the stones thoroughly. As the larger stones are placed, bed them in fresh mortar and shove adjacent stones into contact with one another. After completing the work, spread all excess mortar forced out during placement of the stones uniformly over them to fill all voids completely. Point up all joints roughly either with flush joints or with shallow, smooth-raked joints as directed.
3. **Common.** Construct riprap as shown in Figure 4. Place stones on a bed excavated for the base course. Bed the base course of stone well into the ground with the edges in contact. Bed and place each succeeding course in even contact with the preceding course. Use spalls and small stones to fill any open joints and voids in the riprap. Ensure the finished surface presents an even, tight surface, true to the line and grades of the typical sections.

When the plans require grouting common stone riprap, prevent earth, sand, or foreign material from filling the spaces between the stones. After the stones are in place, wet them thoroughly, fill the spaces between them with grout, and pack. Sweep the surface with a stiff broom after grouting.

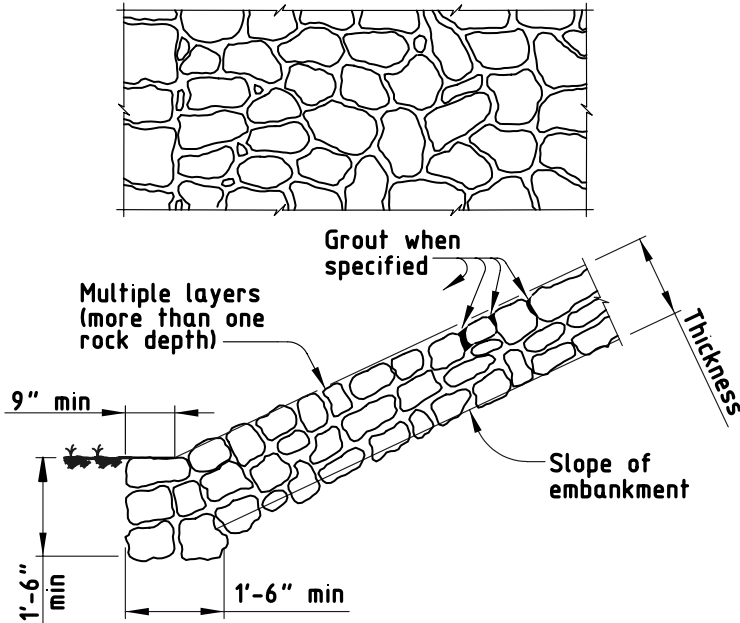

Figure 4
Common stone riprap, dry or grouted.

4. **Protection.** Construct riprap as shown in Figure 5. Place riprap stone on the slopes within the limits shown on the plans. Place stone for riprap on the bedding material to produce a reasonably well-graded mass of riprap with the minimum practicable percentage of voids. Construct the riprap to the lines and grades shown on the plans or staked in the field. A tolerance of +6 in. and -0 in. from the slope line and grades shown on the plans is allowed in the finished surface of the riprap. Place riprap to its full thickness in a single operation. Avoid displacing the bedding material. Ensure that the entire mass of stones in their final position is free from objectionable pockets of small stones and clusters of larger stones. Do not place riprap in layers, and do not

place it by dumping it into chutes, dumping it from the top of the slope, pushing it from the top of the slope, or any method likely to cause segregation of the various sizes. Obtain the desired distribution of the various sizes of stones throughout the mass by selective loading of material at the quarry or other source or by other methods of placement that will produce the specified results. Rearrange individual stones by mechanical equipment or by hand if necessary to obtain a reasonably well-graded distribution of stone sizes.

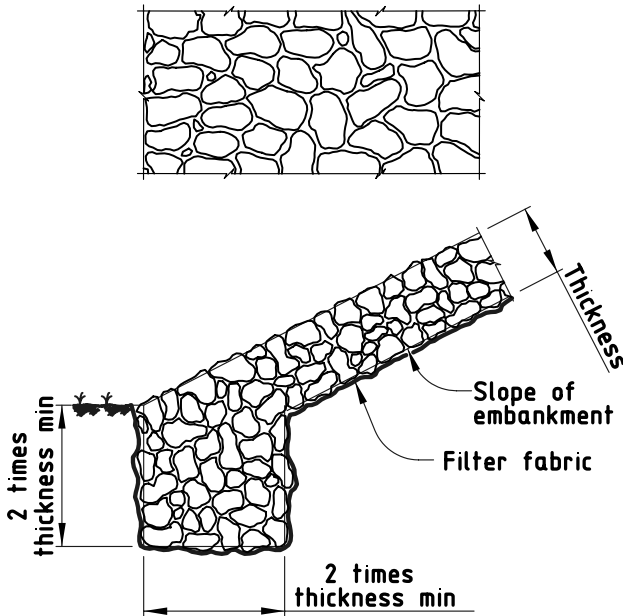

Figure 5
Protection stone riprap.

- C. Pneumatically Placed Concrete Riprap, Class II.** Meet Item 431, "Pneumatically Placed Concrete." Provide reinforcement following the details on the plans and Item 440, "Reinforcing Steel." Support reinforcement with approved supports throughout placement of concrete.

Give the surface a wood-float finish or a gun finish as directed. Immediately after the finishing operation, cure the riprap with

432.4 to 432.5

membrane-curing compound in accordance with Item 420, "Concrete Structures."

- D. Cement-Stabilized Riprap.** Follow the requirements of the plans and the provisions for concrete riprap except when reinforcement is not required. The Engineer will approve the design and mixing of the cement-stabilized riprap.
- E. Special Riprap.** Construct special riprap according to the plans.

432.4. Measurement. This Item will be measured by the cubic yard of material complete in place. Volume will be computed on the basis of the measured area in place and the thickness and toe wall width shown on the plans.

For stone riprap for protection, the quantity of the bedding material to be paid for will be measured by the cubic yard as computed from the measured area in place and the bedding thickness shown on the plans.

432.5. Payment. The work performed and materials furnished in accordance with this Item and measured as provided under "Measurement" will be paid for at the unit price bid for "Riprap" of the type, thickness, and void-filling technique (Dry, Grout, Mortar) specified, as applicable. This price is full compensation for furnishing, hauling, and placing riprap and for filter fabric, expansion joint material, concrete and reinforcing steel, grout and mortar, scales, test weights, equipment, labor, tools, and incidentals.

Payment for excavation of toe wall trenches, for all necessary excavation below natural ground or bottom of excavated channel, and for shaping of slopes for riprap will be included in the unit price bid per cubic yard of riprap.

When bedding is required for protection stone riprap, payment will be made at the unit price for "Bedding Material" of the thickness specified. This price is full compensation for furnishing, hauling, placing, and maintaining the bedding material until placement of the riprap cover is completed and accepted; excavation required for placement of bedding material; and equipment, scales, test weights, labor, tools, and incidentals. No payment will be made for excess thickness of bedding nor for material required to replace embankment material lost by rain wash, wind erosion, or otherwise.

ITEM 434

ELASTOMERIC BRIDGE BEARINGS

434.1. Description. Furnish and install the following elastomeric bridge bearings:

- **Plain Elastomeric Bearings.** Consisting of elastomer only.
- **Laminated Elastomeric Bearings.** Consisting of alternating individual layers of elastomer and steel laminates, with or without a steel top plate and special components (steel guide bars and bottom plate).
- **Sliding Elastomeric Bearings.** Consisting of a steel top plate with a stainless steel facing (upper component) bearing on a preformed fabric pad bonded to a layer of polytetrafluoroethylene (PTFE) material (lower component), with or without special components (steel guide bars and bottom plate).

Plain and laminated elastomeric bridge bearings are designated by hardness (durometer), size, and configuration and, in the case of laminated bearings, by the thickness of the individual layers of elastomer and the size and position of any steel top plates.

434.2. Materials.

- A. Plain and Laminated Elastomeric Bearings.** Furnish bearings produced by a manufacturer prequalified by the Construction Division.
- 1. Elastomer.** Provide elastomer for bearings formulated from previously unvulcanized 100% virgin polychloroprene rubber polymers meeting the requirements of AASHTO M 251, Table 1, unless otherwise shown on the plans. Do not provide bearings containing previously vulcanized synthetic rubber or other synthetic rubber-like polymers. Perform material tests on the finished product in accordance with the applicable test methods. Do not use standard laboratory test slabs for this purpose. Prepare test specimens from the finished product in accordance with ASTM D 3183.
- Obtain approval for each elastomer formulation before use on Department projects. To prequalify and obtain approval of a particular formulation, submit certified test results to the Construction Division. Show actual test values obtained and the required values for the physical properties of the elastomer when tested for compliance with the minimum requirements of AASHTO M 251, Table 1.

434.2 to 434.2

Forward samples (freight prepaid) to the Construction Division, Materials and Pavements Section.

Adhesion testing of laminated prequalification samples will be performed by the Department in accordance with Tex-601-J. Submit only elastomer of the type or types to be supplied. Presence of chlorinated compounds (neoprene) in the elastomer will be verified by the Department in accordance with Tex-601-J. Submit prequalification samples consisting of 2 finished bearings typical of the formulation and workmanship for Department projects. When laminated and plain bearings are required, submit 2 samples of each type.

Plain sample bearings must measure 9 in. × 19 in. × 1 in. with 70-durometer hardness. Laminated sample bearings must measure 9 in. × 14 in. × 1-1/2 in. with the following number of steel laminates:

- 50 durometer—3 steel laminates and
- 60 durometer—2 steel laminates.

Certify that the submitted samples are of the same basic elastomer formulation and of equivalent cure as the finished products to be furnished on Department projects.

Complete prequalification testing will be performed for each formulation at least once every 2 yr. and when necessary.

2. **Steel Laminates.** Provide steel laminates, for laminated bearings, of commercial grade steel strip or sheet with a thickness of 0.105 ± 0.015 in.
3. **Steel Top Plates.** Provide steel top plates, when required for laminated bearings, in accordance with ASTM A 36.
4. **Special Components.** Provide steel guide bars and bottom plates, when required for laminated bearings, in accordance with the plans.

B. Sliding Elastomeric Bearings.

1. Lower Component.

- a. **Preformed Fabric Pad.** Provide preformed fabric pads manufactured of new materials and composed of multiple layers of prestressed duck, 64 plies per inch of finished pad thickness, impregnated and bound with a high quality rubber compound, containing rot and mildew inhibitors and antioxidants, compounded into resilient pads of uniform

thickness. The Shore A durometer hardness of the pad must not be less than 85 nor more than 95. Breakdown must not occur when the preformed fabric pad is subjected to a minimum 10,000-psi compressive stress when tested in accordance with Tex-622-J.

- b. **PTFE.** Furnish PTFE materials that are pure virgin polytetrafluoroethylene fluorocarbon resin, unfilled. Provide finished PTFE sheet between 1/16 and 1/8 in. thick. The finished materials must exhibit the physical properties shown in Table 1.

Table 1
Required PTFE Physical Properties

Physical Property	Test Method	Value (Unfilled)
Tensile strength, psi	ASTM D 4894	2,800 min.
Elongation, %	ASTM D 4894	200 min.
Melting point	ASTM D 4894	622 \pm 4°F
Specific gravity	ASTM D 792	2.16 \pm 0.03

2. Upper Component.

- a. **Steel Plates.** Provide steel plates, unless otherwise shown on the plans, in accordance with ASTM A 36, finished to ANSI #500 or better on the surface interfacing with the stainless steel.
- b. **Stainless Steel.** Provide Type AISI 304 stainless steel sheet in accordance with ASTM A 240. The minimum thickness must be 1/16 in., unless otherwise shown on the plans.
3. **Special Components.** Provide steel guide bars and bottom plates, when required, in accordance with the plans.

434.3. Construction.

- A. **Plain and Laminated Elastomeric Bearings.** Before fabrication of laminated elastomeric bearings with special components, prepare and submit clear and legible shop drawings for the complete assembly in accordance with Section 441.3.A.6.b.(2), "Non-Bridge Structures." Mold together components of a laminated bearing to form an integral unit free of voids or separations in the elastomer or between the elastomer and the steel laminates or plates, unless otherwise shown on the plans. Provide well vulcanized elastomer between the laminates or plates and on the outer surfaces of the bearing that is uniform and

434.3 to 434.3

integral and resists separation by mechanical means into separate, definite, well defined elastomeric layers. Evidence of this layered construction, either at the outer surfaces or within the bearing, will be cause for rejection. Repair of damaged elastomer on sides of laminated bearings is not allowed for product acceptance. Repair of damaged elastomer on top or bottom surfaces of laminated bearings is allowed when approved.

Cover edges of steel laminates with 1/8 in. to 1/4 in. of elastomer except that exposure of the laminates will be permitted at approved laminate restraining devices and around holes entirely enclosed in the finished structure. Position laminates within 1/8 in. of plan location.

Plain bearings may be molded individually, cut from previously molded strips or slabs molded to the full thickness of the finished bearings, or extruded and cut to length. The finish of cut surfaces must be ANSI 250, or smoother. The finished bearings must have no voids or separations detectable either at the bearing surfaces or within the bearing. Plain elastomeric bearings must be well vulcanized, uniform and integral units of such construction that the bearing is incapable of being separated by any mechanical means into separate, definite and well defined elastomeric layers. Evidence of layered construction either at the outer surfaces or within the bearing will be cause for rejection.

The permissible variation from the dimensions and configuration shown on the plans for both plain and laminated bearings will be as listed in AASHTO M 251, Table 2. Flash tolerance, finish, and appearance must meet the requirements of the latest edition of the Rubber Handbook published by the Rubber Manufacturers Association, Inc., RMA F3 and T.063 for molded bearings and RMA F2 for extruded bearings.

Perform required welding in accordance with Item 441, "Steel Structures." Manufacture guide bars, when required, so that adjacent top and bottom bar surfaces are parallel to within 1/16 in. in the assembled position. The tolerance for diameter of anchor bolt holes is +1/8 in., -0. The maximum deviation for flatness of steel plates is 1/16 in. in any 24 in. or as shown on the plans.

1. Markings. Mark the bearing type on the surface of each bearing as shown on the plans. The marking must remain legible until placement in the structure. Permanently mark, in addition, laminated bearings with:

- manufacturer's name or trademark,
- lot number,

- date of manufacture (month-year), and
- direction of slope.

Place this permanent marking on a face which is visible after erection of the bridge, unless otherwise shown on the plans.

2. **Testing and Acceptance.** The sampling, testing, and inspection of plain and laminated bearing production, after prequalification approval, will be as follows:
 - a. **Plain Bearings.** A minimum of 1 plain bearing will be taken by a representative of the Construction Division from each batch or lot. Routine tests for compliance with the requirements of AASHTO M 251 will be performed by the Department. Samples will not be returned.
 - b. **Laminated Bearings.** Subject each laminated bearing to an average compression of 2,250 psi or a stress approved by the Engineer. Provide calibrated equipment per ASTM E 4 for this compression testing. Each bearing will be acceptable if there is no visible evidence of bond failure or other damage, and if the finished bearing meets other pertinent portions of this Item. Samples may be taken if the quality of production becomes questionable.
 - c. **Documentation.** Furnish certified laboratory test results on the elastomer properties of each batch or lot of compound for both plain and laminated bearings. Provide copies of certified mill test reports for laminated bearing steel top plates and any required steel special components.
 3. **Storage.** Plain and laminated bearings must be protected from sunlight until placement in the structure.
 4. **Field Methods.** Provide concrete surfaces for bearing areas under plain and laminated elastomeric bearings in accordance with Section 420.4.H, "Treatment and Finishing of Horizontal Surfaces Other Than Bridge Slabs."

Do not damage the elastomer when welding near bearings. Replace bearings damaged by field welding at the Contractor's expense.
- B. Sliding Elastomeric Bearings.** Before fabrication of sliding elastomeric bearings, prepare and submit clear and legible shop drawings for the complete assembly in accordance with Section 441.3.A.6.b(2), "Non-Bridge Structures."

434.3 to 434.3

Attach the stainless steel sheet to the steel plate by continuous fillet-welding around the edges with an approved welding electrode. Do not extend the weld above the sliding surface. Protect the sliding surface from weld spatter. Provide the finished stainless surface flat to a tolerance of 1/32 in. After attachment to the steel plate, polish the stainless steel sheet to a bright mirror finish less than 20 micro-in. rms and solvent-clean to remove traces of polishing compound.

Provide preformed fabric pads within the following tolerances from plan dimension:

- length and width: +1/4 in., -0 in., and
- thickness: ±5%.

Bond the PTFE material to the preformed fabric pad using approved adhesive methods or by vulcanizing through an appropriate polychloroprene interlayer.

Perform required welding in accordance with Item 441, "Steel Structures." Manufacture guide bars, when required, so that adjacent top and bottom bar surfaces are parallel to within 1/16 in. in the assembled position. The tolerance for diameter of anchor bolt holes is +1/8 in., -0 in. The maximum deviation for flatness of steel plates, except at stainless steel attached surfaces, is 1/16 in. in any 24 in.

1. Testing and Acceptance. Manufacture 1 additional bearing lower component for testing purposes. After bearings have been manufactured for a project, notify the Construction Division, who will sample a bearing lower component at random from the lot.

Determine adhesion between the PTFE material and preformed fabric pad by the 90° peel test specified in ASTM D 429, Method B. The test sample will be 2 in. x 4 in. in size, and must obtain a minimum peel strength of 25 lb. per inch.

Perform check tests, if necessary, on the steel, preformed fabric pads, or PTFE material to verify the properties required under Section 434.2.B, "Sliding Elastomeric Bearings."

Bearings represented by test specimens passing the above requirements will be approved for use in the structure subject to on-site inspection by the Engineer for visible defects.

Furnish copies of certified mill test reports for the stainless steel, upper component steel plates, and any required steel special components. Provide a manufacturer's certification that the preformed fabric and PTFE material meet the requirements of this Item.

2. **Storage.** Store sliding elastomeric bearings horizontally in a dry, sheltered area. Provide moisture and dust resistant wrapping maintained in good condition until installation. Lift bearings only from the undersides. Protect bearings from damage, dirt, oil, grease, and other foreign substances.
3. **Field Methods.** Provide concrete surfaces for bearing areas under sliding elastomeric bearings in accordance with Section 420.4.H, "Treatment and Finishing of Horizontal Surfaces Other Than Bridge Slabs."

Avoid damage to the preformed fabric pad when welding near bearings. Bearings damaged by field welding will be replaced by the Contractor at his expense.

434.4. Measurement.

- A. **Plain and Laminated Elastomeric Bearings.** When plain and laminated elastomeric bearings are specified on the plans to be a pay item, measurement will be by each bearing.
- B. **Sliding Elastomeric Bearings.** Sliding elastomeric bearings will be measured by each bearing.

434.5. Payment.

- A. **Plain and Laminated Elastomeric Bearings.** Plain and laminated elastomeric bearings used with precast prestressed concrete or rolled steel members will not be paid for directly but will be subsidiary to the pertinent Items.

For plain and laminated elastomeric bearings used with post-tensioned concrete superstructures, and with steel girders when specified as a pay item, the work performed and materials furnished in accordance with this Item and measured as provided under "Measurement" will be paid for at the unit price bid for "Elastomeric Bearing" of the type specified. This price is full compensation for materials, including anchor bolts, top plates, steel special components; installation; and tools, equipment, labor, and incidentals.

- B. **Sliding Elastomeric Bearings.** The work performed and materials furnished in accordance with this Item and measured as provided under "Measurement" will be paid for at the unit price bid for "Sliding Elastomeric Bearing" of the type specified. This price is full compensation for the stainless steel faced plate, the PTFE faced preformed fabric pad, the steel special components, the anchor bolts required to connect the bearing between superstructure and

438.1 to 438.4

substructure, installation, materials, equipment, labor, tools, and incidentals.

ITEM 438

CLEANING AND SEALING JOINTS AND CRACKS (RIGID PAVEMENT AND BRIDGE DECKS)

438.1. Description. Clean and seal joints and cracks in new or existing rigid concrete pavements and bridge decks.

438.2. Materials. Use sealants of the class specified on the plans that meet the requirements of DMS-6310, "Joint Sealants and Fillers." If required, use primers recommended by the manufacturer of the sealant. Use backer rods compatible with the sealant that do not react or bond together.

438.3. Equipment. Use equipment that meets sealant manufacturer's recommendations. Use air compressors equipped with appropriate filters for removing oil and water from the air. For grooving cracks, use devices such as diamond-blade random-cut saws or random-crack grinders, capable of following the path of the crack without causing excessive spalling or other damage to the concrete.

438.4. Construction. Before starting work, submit information from the sealant manufacturer showing recommended equipment and installation procedures. All equipment and procedures will be subject to approval. If the equipment causes damage to dowels, reinforcing steel, concrete, base, subbase, or subgrade, repair the damage and change the procedure and equipment to prevent further damage.

A. Preparation. Remove all debris, dirt, dust, saw cuttings, and other foreign material from the crack or joint by an approved method. Collect and dispose of all the removed material.

- 1. Joints.** Remove existing preformed bituminous fiber board material or other spacer material the full depth of the joint along with all other debris in the joint opening. Resize the joint sealant space by sawing to the width and depth shown on the plans to accommodate the type of sealant specified.

On concrete slab and girder bridges, clean debris from the diaphragm windows below the joints.

Abrasive blast clean the vertical faces of joints armored with steel to remove all visible rust, paint, mill scale, and other forms of

contamination, leaving a white metal appearance. Clean concrete and other surfaces by method approved and in accordance with the manufacturer's specifications before placing sealant. After cleaning, air-blast the joint to remove all dust.

2. **Cracks.** Unless otherwise specified, groove the crack at the surface so that a reservoir with a rectangular cross section is provided for the sealant. Cut grooves to the dimensions shown on the plans.

B. Sealing. Place the sealant in accordance with the manufacturer's recommended procedures. Apply the primer, when required, at the specified rate and time interval before applying the sealant. Apply the sealant to dry joint and crack surfaces unless otherwise recommended by the sealant manufacturer. Tool any sealant material that is not self-leveling to force the sealant against the joint surfaces.

1. **Joints.** For concrete pavement, place approved support spacers into joints as shown on the plans. Place a backer rod in the joint opening to prevent the sealant from flowing through the joint and to hold the sealant at its required elevation unless directed otherwise. Set the top of the sealant and thickness of sealant as shown on the plans. Do not place sealant in an expansion-type joint if surface temperature is below 55°F or above 90°F.
2. **Cracks.** Do not place the sealant when the surface temperature is less than 40°F. Set the top of the sealant 1/8 in. to 1/4 in. below the pavement surface, with a minimum depth of sealant of 1/2 in. unless otherwise recommended by the sealant manufacturer.

438.5. Measurement. When specified on the plans to be a pay item, this Item will be measured by the foot or gallon of sealant placed. If measurement is by the gallon, the volume of sealant placed in the joints and cracks will be measured during progress of work.

438.6. Payment. Unless otherwise specified on the plans, the work performed and materials furnished as required by this Item will not be paid for directly but will be subsidiary to bid items of the Contract.

When shown as a pay item, the work performed and materials furnished in accordance with this Item and measured as provided under "Measurement" will be paid for at the unit price bid for "Cleaning and Sealing of Existing Joints," "Cleaning and Sealing Joints," and "Cleaning and Sealing Cracks." This price is full compensation for furnishing all materials; sawing, routing,

439.1 to 439.2

and cleaning and installing; disposing of debris; and equipment, labor, tools, and incidentals.

ITEM 439

CONCRETE BRIDGE DECK OVERLAYS

439.1. Description. Overlay concrete bridge deck surface with concrete, dense concrete, or latex-modified concrete. Remove and replace deteriorated or delaminated concrete.

439.2. Materials. Provide materials conforming to the pertinent requirements of the following Items except as noted in this Item:

- Item 421, “Hydraulic Cement Concrete”
- Item 428, “Concrete Surface Treatment”
- Item 440, “Reinforcing Steel.”

- A. Cement.** Use the same type, brand, and source of cement for any 1 structure. Unless otherwise shown on the plans, use Type I or Type II cement.
- B. Coarse Aggregate.** Provide a crushed or broken coarse aggregate conforming to Grade No. 6 of Section 421.2.E.1, “Coarse Aggregate,” unless used in latex-modified concrete or otherwise shown on the plans. At least 85% of the coarse aggregate particles retained on the No. 4 sieve must have 1 or more mechanically induced crushed faces as determined by Tex-460-A.

Provide an aggregate with an absorption not exceeding 3% when tested in accordance with Tex-403-A, for dense concrete overlays.

For latex-modified concrete, provide aggregate conforming to Grade No. 8 of Section 421.2.E.1, “Coarse Aggregate,” unless otherwise specified.

- C. Latex.** Provide latex admixture (ASTM C 1438, Type II polymer modifier) meeting the requirements of Table 1.

Table 1
Physical Requirements for Polymer Modifier

Property	Requirement
Total solids	> 47%
pH	9.0 to 11.0
Brookfield viscosity, #1 spindle @ 10 rpm	5 to 40 cPs
Butadiene content	30 to 40%
Weight per gallon	8.4 to 8.6 lb./gal.

Store latex at temperatures between 40°F and 85°F. Do not allow latex to freeze.

- D. Grout.** When shown on the plans, provide grout for bonding new concrete to existing concrete, consisting of equal parts by weight of hydraulic cement and sand. Mix with sufficient water to form a stiff slurry, which can be applied with a stiff brush or broom to the existing concrete in a thin, even coating that will not run or puddle in low spots.

439.3. Equipment.

A. Surface Preparation Equipment.

1. **Scarifying.** Provide equipment meeting the requirements of Item 483, “Scarifying Concrete Bridge Slab.”
2. **Abrasive Blasting.** Provide equipment capable of removing oil, dirt, slurry, curing compound, laitance, etc., from the surface of the concrete.
3. **Sawing.** When required, provide equipment capable of sawing concrete to the specified depth of overlay.
4. **Power-Driven Chipping Tools.** Provide tools not heavier than a nominal 30-lb. class for removal of concrete.
5. **Chipping Hammers.** Provide chipping hammers not heavier than a nominal 15-lb. class to remove concrete beneath any reinforcing bars.

B. Proportioning and Mixing Equipment.

1. **Grout Mixer.** Provide a volumetric continuous or mortar mixer.
2. **Concrete Overlay.** Follow applicable provisions of Item 421, “Hydraulic Cement Concrete.”
3. **Dense Concrete Overlay.** Follow applicable provisions of Item 421, “Hydraulic Cement Concrete.” Proportion and mix the

439.4 to 439.4

concrete at the project site using a suitable approved mixer capable of thoroughly mixing the ingredients to a uniform consistency.

4. **Latex-Modified Concrete Overlay.** Follow the applicable provisions of Item 421, "Hydraulic Cement Concrete." Proportion and mix the latex-modified concrete at the project site using a suitable approved mixer capable of thoroughly mixing the ingredients to a uniform consistency.

C. **Placing and Finishing Equipment.**

1. **Hand Tools.** Provide sufficient hand tools for placing, consolidating, striking off, and finishing stiff plastic concrete.
2. **Finishing Equipment for Concrete Overlay.** Provide an approved surface vibrator moving ahead of the finishing machine or an approved vibrating screed for overlay consolidation. Provide work bridges or other suitable facilities to perform all finishing operations.
3. **Finishing Equipment for Dense Concrete or Latex-Modified Concrete Overlay.** Provide a mechanical strike-off to ensure a uniform thickness of concrete in front of the screed. Provide a screed designed to consolidate the dense concrete overlay to 98% of the unit weight as determined in accordance with Tex-417-A. Design the bottom face of the screed to minimize tearing of the surface of the plastic concrete.

Provide a finishing machine capable of forward and reverse motion under positive control. Make appropriate provisions for raising the screeds to clear the screeded surface for traveling in reverse. Equip the finishing machine to travel on and screed off of any adjacent completed lane without damaging it. Use approved manual screeds and vibrators to consolidate and finish small or irregular areas inaccessible to the finishing machine. Provide work bridges or other suitable facilities to perform finishing operations and density checks.

439.4. **Construction.**

- A. **General.** Provide for approval a detailed work plan including equipment and manpower before beginning any work.

The Engineer will inform the Contractor if night placements become necessary. No additional compensation will be provided for night placements of concrete. Provide sufficient lighting to make quality

workmanship and adequate inspection possible during night placements. Lighting must be approved before operations begin.

Provide sufficient labor and equipment for proportioning, mixing, placing, and finishing concrete overlay at a rate of at least 40 ft. of finished overlay per hour. Do not allow traffic other than construction equipment for the overlay on any portion of the prepared bridge deck before the overlay has been placed. Provide side and end forms for supporting the screed and containing the overlay concrete. Provide reinforcement, when required, in accordance with Item 440, "Reinforcing Steel," and the details shown on the plans.

Place concrete only when the air or deck temperature is 40°F or above and the concrete temperature is between 50°F and 85°F. Do not cart concrete batches over the completed overlay until the overlay concrete has attained a 3,000-psi compressive or 425-psi flexural strength. If carts are used, provide timber planking of at least 3/4-in. thickness for the remainder of the curing period. Provide carts equipped with pneumatic tires. Do not interrupt curing operations for the purpose of carting concrete over finished slabs.

Open the structure with the completed overlay to normal construction traffic or to the traveling public in accordance with Section 420.4.A, "Schedule Restrictions."

- B. Surface Preparation.** Do not scarify concrete surfaces with a grooved or tined finish unless shown on the plans. Prepare these surfaces by abrasive blasting or water-injected abrasive blasting as required to remove dirt, oil, curing compound, laitance, surface mortar, and other material that would inhibit bonding of the overlay but leave the striations intact.

Scarify the surfaces of slabs to be rehabilitated to the depths shown on the plans in accordance with Item 483, "Scarifying Concrete Bridge Slab."

Remove and dispose of deteriorated or delaminated areas of concrete as shown on the plans or as determined by the use of a sounding hammer, chain drag, or other acceptable device and by visual inspection after scarifying as approved.

Type 1 Slab Repair consists of removing deteriorated concrete from the top of the scarified surface to 1/2 the depth of the slab, and replacing it with concrete as specified for the overlay. Areas where deteriorated concrete extends below mid-depth of the slab will be designated as Type 2 repairs.

439.4 to 439.4

Type 2 Slab Repair consists of removing deteriorated concrete from the top of the scarified surface to the bottom of the slab and replacing it with concrete as specified for concrete overlays or Class S concrete for dense concrete or latex-modified concrete overlays. Remove any unsound areas of a Type 1 repair that extend below the maximum depth for a Type 1 repair in accordance with the requirements for a Type 2 repair. This area will be designated as a Type 2 repair for payment.

Use a jackhammer not heavier than a nominal 30-lb. class to remove deteriorated concrete in small areas not accessible to the mechanical scarifier, and to spot-remove small areas of deteriorated concrete to a depth down to the existing top reinforcing steel. This class of jackhammer may also be used for concrete removal between existing reinforcing bars to a greater depth. Use chipping hammers not heavier than a nominal 15-lb. class to remove concrete from beneath any reinforcing bars. Avoid cutting, stretching, or damaging exposed reinforcing steel by direct impact of these power tools. Repair or replace reinforcing steel damaged during the concrete removal process at no additional expense to the Department. Operate all jackhammers and chipping hammers at an angle of 45° or less measured from the surface of the slab.

When the bond between existing concrete and reinforcing steel that will remain in place has been destroyed, remove the concrete adjacent to and below the bar to a minimum depth of 1 in. below the bar to permit the new concrete to bond to the entire periphery of the exposed bar.

Clean all exposed reinforcing steel, scarified surfaces, and newly exposed concrete surfaces including construction joints against curbs or parapet walls by wet or dry grit blasting before placing the concrete. Blast corroded reinforcing steel to gray metal. Remove and place all blast debris in an approved disposal site. Repair or replace damaged reinforcing steel as required.

Water-blast surfaces prepared by abrasive blasting or water-injected abrasive blasting. Remove windblown dust, dirt, debris, or standing water from the surface with a high-pressure filtered air-blasting just before placing the grout.

- C. **Classification and Mix Design.** Provide a mix design in accordance with Item 421, "Hydraulic Cement Concrete." Use a water reducing chemical admixture as necessary to achieve the desired consistency without exceeding the specified water to cementitious material ratio. Provide a mix design with an entrained air content of the fresh concrete of 6% with a tolerance of $\pm 1\%$ when tested in accordance with

Tex-414-A, “Air Content of Freshly Mixed Concrete by the Volumetric Method,” or Tex-416-A, “Air Content of Freshly Mixed Concrete by the Pressure Method,” together with the following requirements:

1. **Concrete Overlay.** Provide Class CO concrete with a coarse aggregate factor of at least 0.55.
 2. **Dense Concrete Overlay.** Provide Class DC concrete with a coarse aggregate factor that will provide equal absolute volumes of fine aggregate and coarse aggregate with a tolerance of $\pm 5\%$.
 3. **Latex-Modified Concrete.** Provide Class LMC concrete with a minimum cement content of 658 lb. per cubic yard, a minimum latex admixture content of 24.5 gal. per cubic yard, and a maximum water content of 18.9 gal. per cubic yard. Provide a mix design using a coarse aggregate volume of 30 to 45% by weight of the total aggregate and a weight ratio of cement to sand to coarse aggregate of 1.0:2.8:1.7 based on aggregate in a saturated surface-dry condition. Use a commercially available antifoaming agent with the polymer modifier as necessary to control the air content in the mix.
- D. Placing and Finishing Concrete.** Grade the screed rails or headers to ensure the concrete is finished to the required profile. Place the rails or headers outside the area to be overlaid. Provide anchorage of headers or supporting rails for horizontal and vertical stability as necessary. A hold-down device anchored into the concrete will not be permitted unless the concrete is to be subsequently overlaid. Obtain approval for plans for anchor support of headers or rails before beginning work.

Provide the overlay thickness specified on the plans. Adjust the screed and screed rail as necessary to provide the approved grade and required thickness. For nonreinforced overlays, check the clearance between the screed and existing surface by attaching a filler block with a thickness of 1/8 in. less than the overlay thickness to the bottom of the screed. With the filler block in place, pass the screed over the area to be overlaid. Correct any areas having insufficient clearance by adjusting the screed and rail system or by chipping or scarifying as approved by the Engineer. For reinforced overlays, check screed clearance and reinforcement cover as approved by the Engineer.

Construct longitudinal joints at locations shown on the plans or as approved. Construct a straight and vertical edge at transverse and longitudinal construction joints. Saw joints before placing the adjacent overlay course.

439.4 to 439.4

Install expansion joints in the overlay at the same locations as the expansion joints in the deck.

Moisten the prepared surface to a saturated surface-dry condition just before placing the overlay concrete. Remove standing water from the surface before placing the overlay concrete.

Do not use bonding grout unless otherwise required on the plans or by this Item. When bonding grout is required, moisten the prepared surface to an approximately saturated surface-dry condition before placing bonding grout. Scrub a thin coating of grout into the prepared surface immediately before placing the concrete. Ensure that all surfaces including vertical joints receive a thorough, even coating and that no excess grout collects in pockets. Apply the grout so that it does not become dry before it is covered with concrete. Coat areas of the bridge deck where concrete has been removed below the top mat of reinforcing steel with bonding grout if required, and fill them with overlay concrete or Class S concrete as applicable to cover the reinforcing steel. Adequately consolidate and rough float these areas just ahead of the overlay placement.

Place and mechanically strike off the overlay concrete slightly above the final grade. Follow this strike-off by mechanically consolidating and screeding the surface to the final grade. Vibrate all concrete into the corners and angles of the edges. Hand-finish the surface with a float as necessary to produce a tight, uniform surface.

Consolidate dense concrete to 98% density as determined in accordance with Tex-451-A after screeding and before applying the surface texture.

Assure dense, watertight construction joints by properly consolidating the concrete and float-finishing the top surface of the joint flush with the adjacent concrete.

Meet the straightedge and finishing requirements specified in Section 420.4.I, "Finish of Bridge Slabs," for the finishing of the concrete overlay.

- E. Curing.** Wet-burlap cure the overlay as soon as possible after the concrete has been textured. Overlay that dries out or cracks before the wet burlap is applied will be rejected. Keep the burlap continuously wet for 24 hr. Water-cure the overlay in accordance with Section 420.4.J, "Curing Concrete," for an additional 7 days. Maintain the surface temperature of the concrete above 40°F for the required curing period. Remove and replace rejected overlay concrete at no additional cost to the Department.

F. Concrete Surface Treatment. Apply concrete surface treatment to the overlay in accordance with Item 428, “Concrete Surface Treatment.”

439.5. Measurement. The removal of deteriorated or delaminated concrete for slab repair will be measured by the square yard of surface area, measured in place.

Concrete overlay, dense concrete overlay, and latex-modified concrete overlay will be measured by the square yard of surface overlaid using the dimensions shown on the plans. Overlay is a plans quantity measurement item. The quantity to be paid is the quantity shown in the proposal, unless modified by Article 9.2, “Plans Quantity Measurement.” Additional measurements or calculations will be made if adjustments of quantities are required.

439.6. Payment. The work performed and materials furnished in accordance with this Item and measured as provided under “Measurement” will be paid for at the unit price bid for “Slab Repair (Type 1)” and “Slab Repair (Type 2)” and for “Concrete Overlay,” “Dense Concrete Overlay,” and “Latex-Modified Concrete Overlay” of the specified depth.

Payment for “Slab Repair (Type 1)” and “Slab Repair (Type 2)” is full compensation for removal of deteriorated or delaminated concrete below the top of scarified surface, cleaning and restoration of reinforcing steel, and replacement with concrete.

Payment for “Concrete Overlay,” “Dense Concrete Overlay,” or “Latex-Modified Concrete Overlay” is full compensation for abrasion blasting of the surface; furnishing and placing grout; reinforcing steel; and furnishing, placing, finishing and curing the concrete overlay. Scarifying will be paid for in accordance with Item 483, “Scarifying Concrete Bridge Slab.”

These prices are full compensation for materials, tools, equipment, labor, and incidentals.

ITEM 440 REINFORCING STEEL

440.1. Description. Furnish and place reinforcing steel of the sizes and details shown on the plans.

440.2. Materials.

A. Approved Mills. Before furnishing steel, producing mills of reinforcing steel for the Department must be pre-approved in

440.2 to 440.2

accordance with DMS-7320, “Qualification Procedure for Reinforcing Steel Mills,” by the Construction Division, which maintains a list of approved producing mills. Reinforcing steel obtained from unapproved sources will not be accepted.

B. Deformed Bar and Wire Reinforcement. Unless otherwise shown on the plans, reinforcing steel must be Grade 60, and bar reinforcement must be deformed. Reinforcing steel must conform to one of the following:

- ASTM A 615, Grades 40 or 60;
- ASTM A 996, Type A, Grades 40 or 60;
- ASTM A 996, Type R, Grade 60, permitted in concrete pavement only (Furnish ASTM A 996, Type R bars as straight bars only and do not bend them. Bend tests are not required.); or
- ASTM A 706.

The provisions of this Item take precedence over ASTM provisions.

The nominal size, area, and weight of reinforcing steel bars covered by this Item are shown in Table 1. Designate smooth bars up to No. 4 by size number and above No. 4 by diameter in inches.

Table 1
Size, Area, and Weight of Reinforcing Steel Bars

Bar Size Number (in.)	Bar Size Number (mm)	Diameter (in.)	Area (Sq. in.)	Weight per Ft.
3	10	0.375	0.11	0.376
4	13	0.500	0.20	0.668
5	16	0.625	0.31	1.043
6	19	0.750	0.44	1.502
7	22	0.875	0.60	2.044
8	25	1.000	0.79	2.670
9	29	1.128	1.00	3.400
10	32	1.270	1.27	4.303
11	36	1.410	1.56	5.313
14	43	1.693	2.25	7.650
18	57	2.257	4.00	13.60

Note: Bar size numbers (in.) are based on the number of eighths of an inch included in the nominal diameter of the bar. Bar size numbers (mm) approximate the number of millimeters included in the nominal diameter of the bar.

C. Smooth Bar and Spiral Reinforcement. Smooth bars and dowels for concrete pavement must have a minimum yield strength of 60 ksi and

meet ASTM A 615. For smooth bars that are larger than No. 3, provide steel conforming to ASTM A 615 or meet the physical requirements of ASTM A 36.

Spiral reinforcement may be smooth or deformed bars or wire of the minimum size or gauge shown on the plans. Bars for spiral reinforcement must comply with ASTM A 615, Grade 40; ASTM A 996, Type A, Grade 40; or ASTM A 675, Grade 80, meeting dimensional requirements of ASTM A 615. Smooth wire must comply with ASTM A 82, and deformed wire must comply with ASTM A 496.

- D. Weldable Reinforcing Steel.** Reinforcing steel to be welded must comply with ASTM A 706 or have a carbon equivalent (C.E.) of at most 0.55%. A report of chemical analysis showing the percentages of elements necessary to establish C.E. is required for reinforcing steel that does not meet ASTM A 706 to be structurally welded. These requirements do not pertain to miscellaneous welds on reinforcing steel as defined in Section 448.4.B.1.a, "Miscellaneous Welding Applications."

Calculate C.E. using the following formula:

$$C.E. = \%C + \frac{\%Mn}{6} + \frac{\%Cu}{40} + \frac{\%Ni}{20} + \frac{\%Cr}{10} - \frac{\%Mo}{50} - \frac{\%V}{10}$$

- E. Welded Wire Fabric.** For fabric reinforcement, use wire that conforms to ASTM A 82 or A 496. Use wire fabric that conforms to ASTM A 185 or A 497. Observe the relations shown in Table 2 among size number, diameter in inches, and area when ordering wire by size numbers, unless otherwise specified. Precede the size number for deformed wire with "D" and for smooth wire with "W."

Designate welded wire fabric as shown in the following example: 6 × 12 – W16 × W8 (indicating 6-in. longitudinal wire spacing and 12-in. transverse wire spacing with smooth No. 16 wire longitudinally and smooth No. 8 wire transversely).

Table 2
Wire Size Number, Diameter, and Area

Size Number (in.)	Size Number (mm)	Diameter (in.)	Area (sq. in.)
31	200	0.628	0.310
30	194	0.618	0.300
28	181	0.597	0.280
26	168	0.575	0.260
24	155	0.553	0.240
22	142	0.529	0.220
20	129	0.505	0.200
18	116	0.479	0.180
16	103	0.451	0.160
14	90	0.422	0.140
12	77	0.391	0.120
10	65	0.357	0.100
8	52	0.319	0.080
7	45	0.299	0.070
6	39	0.276	0.060
5.5	35	0.265	0.055
5	32	0.252	0.050
4.5	29	0.239	0.045
4	26	0.226	0.040
3.5	23	0.211	0.035
2.9	19	0.192	0.035
2.5	16	0.178	0.025
2	13	0.160	0.020
1.4	9	0.134	0.014
1.2	8	0.124	0.012
0.5	3	0.080	0.005

Note: Size numbers (in.) are the nominal cross-sectional area of the wire in hundredths of a square inch. Size numbers (mm) are the nominal cross-sectional area of the wire in square millimeters. Fractional sizes between the sizes listed above are also available and acceptable for use.

- F. Epoxy Coating.** Epoxy coating will be required as shown on the plans. Before furnishing epoxy-coated reinforcing steel, an epoxy applicator must be pre-approved in accordance with DMS-7330, "Qualification Procedure for Reinforcing Steel Epoxy Coating Applicators." The Construction Division maintains a list of approved applicators.

Coat reinforcing steel in accordance with Table 3.

Table 3
Epoxy Coating Requirements for Reinforcing Steel

Material	Specification
Bar	ASTM A 775 or A 934
Wire or fabric	ASTM A 884 Class A or B
Mechanical couplers	As shown on the plans
Hardware	As shown on the plans

Use epoxy coating material and coating repair material that complies with DMS-8130, "Epoxy Powder Coating for Reinforcing Steel." Do not patch more than 1/4 in. total length in any foot at the applicator's plant.

Epoxy-coated reinforcement will be sampled and tested in accordance with Tex-739-I.

Maintain identification of all reinforcing throughout the coating and fabrication and until delivery to the project site.

Furnish 1 copy of a written certification that the coated reinforcing steel meets the requirements of this Item and 1 copy of the manufacturer's control tests.

G. Mechanical Couplers. When mechanical splices in reinforcing steel bars are shown on the plans, use the following types of coupler:

- sleeve-filler,
- sleeve-threaded,
- sleeve-swaged, or
- sleeve-wedge.

Furnish only couplers that have been produced by a manufacturer that has been prequalified in accordance with DMS-4510, "Mechanical Couplers." Sleeve-wedge type couplers will not be permitted on coated reinforcing. Couplers for use on individual projects must be sampled and tested in accordance with DMS-4510. Furnish couplers only at locations shown on the plans.

440.3. Construction.

A. Bending. Cold-bend the reinforcement accurately to the shapes and dimensions shown on the plans. Fabricate in the shop if possible. Field-fabricate, if permitted, using a method approved by the Engineer. Replace improperly fabricated, damaged, or broken bars at no additional expense to the Department. Repair damaged or broken bars embedded in a previous concrete placement using a method approved by the Engineer.

440.3 to 440.3

Unless otherwise shown on the plans, the inside diameter of bar bends, in terms of the nominal bar diameter (d), must be as shown in Table 4.

Table 4
Minimum Inside Diameter of Bar Bends

Bend	Bar Size Number (in.)	Bar Size Number (mm)	Diameter
Bends of 90° and greater in stirrups, ties, and other secondary bars that enclose another bar in the bend	3, 4, 5	10, 13, 16	4d
	6, 7, 8	19, 22, 25	6d
Bends in main bars and in secondary bars not covered above	3 through 8	10 through 25	6d
	9, 10, 11	29, 32, 36	8d
	14, 18	43, 57	10d

Note: Bar size numbers (in.) are based on the number of eighths of an inch included in the nominal diameter of the bar. Bar size numbers (mm) approximate the number of millimeters included in the nominal diameter of the bar.

Where bending No. 14 or No. 18 Grade 60 bars is required, bend-test representative specimens as described for smaller bars in the applicable ASTM specification. Make the required 90° bend around a pin with a diameter of 10 times the nominal diameter of the bar.

B. Tolerances. Fabrication tolerances for bars are shown in Figure 1.

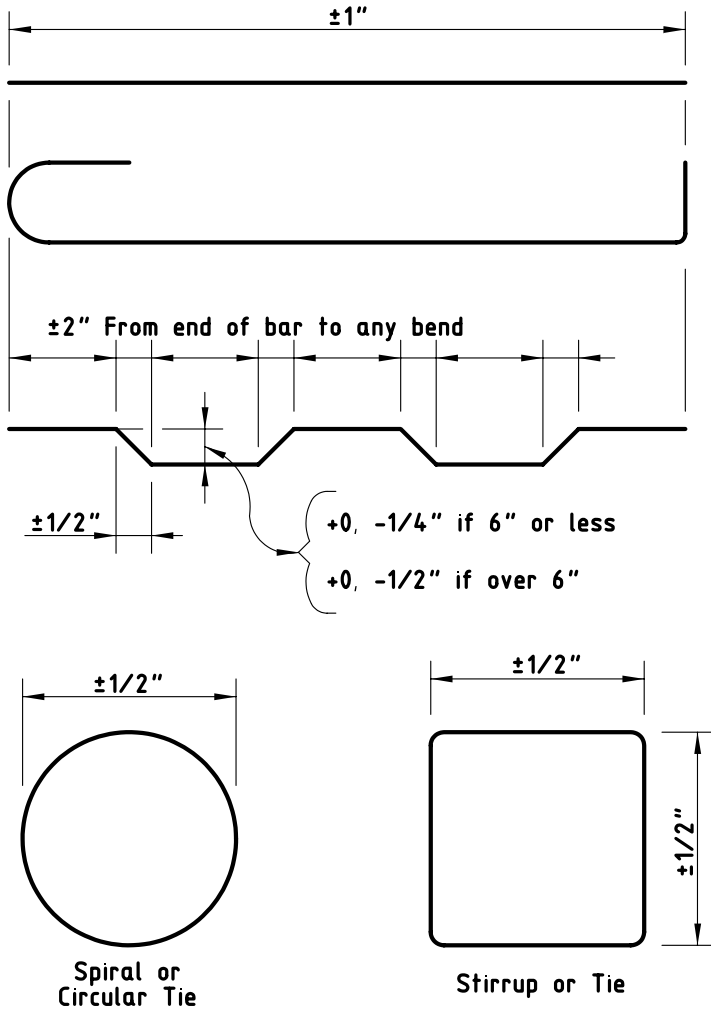

Figure 1
Fabrication tolerances for bars.

- C. **Storage.** Store steel reinforcement above the ground on platforms, skids, or other supports, and protect it from damage and deterioration. Ensure that reinforcement is free from dirt, paint, grease, oil, and other foreign materials when it is placed in the work. Use reinforcement free

from defects such as cracks and delaminations. Rust, surface seams, surface irregularities, or mill scale will not be cause for rejection if the minimum cross-sectional area of a hand wire-brushed specimen meets the requirements for the size of steel specified.

D. Splices. Lap-splice, weld-splice, or mechanically splice bars as shown on the plans. Additional splices not shown on the plans will require approval. Splices not shown on the plans will be permitted in slabs 15 in. or less in thickness, columns, walls, and parapets.

- Unless otherwise approved, splices will not be permitted in bars 30 ft. or less in plan length. For bars exceeding 30 ft. in plan length, the distance center-to-center of splices must be at least 30 ft. minus 1 splice length, with no more than 1 individual bar length less than 10 ft. Make lap splices not shown on the plans, but otherwise permitted, in accordance with Table 5. Maintain the specified concrete cover and spacing at splices, and place the lap-spliced bars in contact, securely tied together.

**Table 5
Minimum Lap Requirements for Bar Sizes through No. 11**

Bar Size Number (in.)	Bar Size Number (mm)	Uncoated Lap Length	Coated Lap Length
3	10	1 ft. 4 in.	2 ft. 0 in.
4	13	1 ft. 9 in.	2 ft. 8 in.
5	16	2 ft. 2 in.	3 ft. 3 in.
6	19	2 ft. 7 in.	3 ft. 11 in.
7	22	3 ft. 5 in.	5 ft. 2 in.
8	25	4 ft. 6 in.	6 ft. 9 in.
9	29	5 ft. 8 in.	8 ft. 6 in.
10	32	7 ft. 3 in.	10 ft. 11 in.
11	36	8 ft. 11 in.	13 ft. 5 in.

Note: Bar size numbers (in.) are based on the number of eighths of an inch included in the nominal diameter of the bar. Bar size numbers (mm) approximate the number of millimeters included in the nominal diameter of the bar.

- Do not lap No. 14 or No. 18 bars.
- Lap spiral steel at least 1 turn.
- Splice welded wire fabric using a lap length that includes the overlap of at least 2 cross wires plus 2 in. on each sheet or roll. Splices using bars that develop equivalent strength and are lapped in accordance with Table 5 are permitted.

- For box culvert extensions with less than 1 ft. of fill, lap the existing longitudinal bars with the new bars as shown in Table 3. For extensions with more than 1 ft. of fill, lap at least 1 ft. 0 in.
- Ensure that welded splices conform to the requirements of the plans and of Item 448, “Structural Field Welding.” Field-prepare ends of reinforcing bars if they will be butt-welded. Delivered bars must be long enough to permit weld preparation.
- Install mechanical coupling devices in accordance with the manufacturer’s recommendations at locations shown on the plans. Protect threaded male or female connections, and make sure the threaded connections are clean when making the connection. Do not repair damaged threads.
- Mechanical coupler alternate equivalent strength arrangements, to be accomplished by substituting larger bar sizes or more bars, will be considered if approved in writing before fabrication of the systems.

E. Placing. Unless otherwise shown on the plans, dimensions shown for reinforcement are to the centers of the bars. Place reinforcement as near as possible to the position shown on the plans. In the plane of the steel parallel to the nearest surface of concrete, bars must not vary from plan placement by more than 1/12 of the spacing between bars. In the plane of the steel perpendicular to the nearest surface of concrete, bars must not vary from plan placement by more than 1/4 in. Cover of concrete to the nearest surface of steel must be at least 1 in. unless otherwise shown on the plans.

For bridge slabs, the clear cover tolerance for the top mat of reinforcement is $-0, +1/2$ in.

Locate the reinforcement accurately in the forms, and hold it firmly in place before and during concrete placement by means of bar supports that are adequate in strength and number to prevent displacement and to keep the steel at the proper distance from the forms. Support bars by standard bar supports with plastic tips, approved plastic bar supports, or precast mortar or concrete blocks when supports are in contact with removable or stay-in-place forms. Use bright basic bar supports to support reinforcing steel placed in slab overlays on concrete panels or on existing concrete slabs. Bar supports in contact with soil or subgrade must be approved.

For bar supports with plastic tips, the plastic protection must be at least 3/32 in. thick and extend upward on the wire to a point at least 1/2 in. above the formwork.

440.3 to 440.3

All accessories such as tie wires, bar chairs, supports, or clips used with epoxy-coated reinforcement must be of steel, fully coated with epoxy or plastic. Plastic supports approved by the Engineer may also be used with epoxy-coated reinforcement.

Cast mortar or concrete blocks to uniform dimensions with adequate bearing area. Provide a suitable tie wire in each block for anchoring to the steel. Cast the blocks to the thickness required in approved molds. The surface placed adjacent to the form must be a true plane, free of surface imperfections. Cure the blocks by covering them with wet burlap or mats for a period of 72 hr. Mortar for blocks should contain approximately 1 part hydraulic cement to 3 parts sand. Concrete for blocks should contain 850 lb. of hydraulic cement per cubic yard of concrete.

Place individual bar supports in rows at 4-ft. maximum spacing in each direction. Place continuous type bar supports at 4-ft. maximum spacing. Use continuous bar supports with permanent metal deck forms.

The exposure of the ends of longitudinals, stirrups, and spacers used to position the reinforcement in concrete pipe and in precast box culverts or storm drains is not cause for rejection.

Tie reinforcing steel for bridge slabs, top slabs of direct traffic culverts, and top slabs of prestressed box beams at all intersections, except tie only alternate intersections where spacing is less than 1 ft. in each direction. For reinforcing steel cages for other structural members, tie the steel at enough intersections to provide a rigid cage of steel. Fasten mats of wire fabric securely at the ends and edges.

Before concrete placement, clean mortar, mud, dirt, debris, oil, and other foreign material from the reinforcement. Do not place concrete until authorized.

If reinforcement is not adequately supported or tied to resist settlement, reinforcement is floating upward, truss bars are overturning, or movement is detected in any direction during concrete placement, stop placement until corrective measures are taken.

F. Handling, Placement, and Repair of Epoxy-Coated Reinforcing Steel.

- 1. Handling.** Provide systems for handling coated reinforcement with padded contact areas. Pad bundling bands or use suitable banding to prevent damage to the coating. Lift bundles of coated reinforcement with a strongback, spreader bar, multiple supports, or a platform bridge. Transport the bundled reinforcement

carefully, and store it on protective cribbing. Do not drop or drag the coated reinforcement.

2. **Construction Methods.** Do not flame-cut coated reinforcement. Saw or shear-cut only when approved. Coat cut ends as specified in Section 440.3.F.3, "Repair of Coating."

Do not weld or mechanically couple coated reinforcing steel except where specifically shown on the plans. Remove the epoxy coating at least 6 in. beyond the weld limits before welding and 2 in. beyond the limits of the coupler before assembly. After welding or coupling, clean the steel of oil, grease, moisture, dirt, welding contamination (slag or acid residue), and rust to a near-white finish. Check the existing epoxy for damage. Remove any damaged or loose epoxy back to sound epoxy coating.

After cleaning, coat the splice area with epoxy repair material to a thickness of 7 to 17 mils after curing. Apply a second application of repair material to the bar and coupler interface to ensure complete sealing of the joint.

3. **Repair of Coating.** For repair of the coating, use material that complies with the requirements of this Item and ASTM D 3963. Make repairs in accordance with procedures recommended by the manufacturer of the epoxy coating powder. For areas to be patched, apply at least the same coating thickness as required for the original coating. Repair all visible damage to the coating.

Repair sawed and sheared ends, cuts, breaks, and other damage promptly before additional oxidation occurs. Clean areas to be repaired to ensure that they are free from surface contaminants. Make repairs in the shop or in the field as required.

440.4. Measurement and Payment. The work performed, materials furnished, equipment, labor, tools, and incidentals will not be measured or paid for directly but will be considered subsidiary to pertinent Items.

ITEM 441 STEEL STRUCTURES

441.1. Description. Fabricate and erect structural steel and other metals used for steel structures or for steel portions of structures.

441.2 to 441.3

441.2. Materials.

- A. **Base Metal.** Use metal that meets Item 442, “Metal for Structures.”
- B. **Approved Electrodes and Flux-Electrode Combinations.** Use only electrodes and flux–electrode combinations found on the list of approved electrodes and flux–electrode combinations maintained by the Construction Division. To request that a product be added to this list or to renew an expired approval, submit certified reports of all tests required by the applicable AWS A5 specification according to the applicable welding code (for most construction, AASHTO/AWS D1.5, *Bridge Welding Code*, or AWS D1.1, *Structural Welding Code—Steel*) to the Construction Division, Materials and Pavements Section.
- C. **High-Strength Bolts.** Use fasteners that meet Item 447, “Structural Bolting.”
- D. **Coatings.** Provide coating materials, as required, in accordance with Item 445, “Galvanizing,” and Item 446, “Cleaning and Painting Steel.”

441.3. Construction.

A. General Requirements.

1. **Applicable Codes.** Perform all fabrication in accordance with AASHTO/NSBA Steel Bridge Collaboration S2.1, including fabrication of non-bridge members. Follow all applicable provisions of the appropriate AWS code (D1.5 or D1.1) except as otherwise noted in the plans or in this Item. Weld sheet steel (thinner than 1/8 in.) in accordance with ANSI/AWS D1.3, *Structural Welding Code—Sheet Steel*. Unless otherwise stated, requirements of this Item are in addition to the requirements of S2.1. Perform all bolting in accordance with Item 447, “Structural Bolting.”
2. **Primary Members.** Primary members include:
 - webs and flanges of plate, tub, and box girders;
 - rolled beams and cover plates;
 - floor beam webs and flanges;
 - arch ribs and arch tie beams or girders;
 - truss members;
 - diaphragm members for curved plate girders or beams;
 - pier diaphragm members for tub girders;
 - splice plates for primary members; and
 - any other member designated as “primary” or “main” on the plans.

3. **Responsibility.** The Contractor is responsible for the correctness and completeness of shop drawings and for the fit of shop and field connections.
4. **Railroad Structures.** Fabricate railroad underpass structures in accordance with the latest AREMA *Manual for Railway Engineering* and this Item. In the case of a conflict between this Item and the AREMA manual, the more stringent requirements apply.
5. **Qualification of Plant, Laboratories, and Personnel.**
 - a. **Fabrication.** The Department will evaluate fabrication plants for competence of the plant, equipment, organization, experience, knowledge, and personnel to produce acceptable work. Plants must be qualified in accordance with S2.1 (or equal acceptable qualification). When AISC certification is required, provide a copy of the certificate and a copy of the complete audit report, including the exit meeting report.
 - b. **Nondestructive Examination (NDE).** Personnel performing NDE must be qualified in accordance with the applicable AWS code. Testing agencies and individual third-party contractors must also successfully complete periodic audits for compliance, performed by the Department. In addition, ultrasound technicians must pass a hands-on test administered by the Construction Division. A technician who fails the hands-on test must wait 6 months before taking the test again. Qualification to perform ultrasonic testing for the Department will be revoked when the technician's employment is terminated, and recertification based on a new hands-on test will be required.
 - c. **Welding Procedure Qualification.** Laboratories performing testing for welding procedure qualification must successfully complete periodic audits in accordance with DMS-7360, "Qualification Procedure for Laboratories Performing Welding Procedure Qualification Testing."
6. **Drawings.**
 - a. **Erection Drawings.** Submit 2 copies of erection drawings in accordance with Item 5, "Control of the Work," before erection of railroad underpasses, trusses, field-spliced (welded or bolted) girders, arches, or other members for which erection drawings are required on the plans. Submit an additional copy

of the drawings for railroad underpasses. Erection drawings are not required for rolled I-beam units unless otherwise noted on the plans.

Clearly indicate at least:

- procedures;
- sequence of work;
- equipment to be used;
- location of falsework, erection cranes, and holding cranes;
- falsework design details;
- girder lifting points;
- adjacent structures loaded; and
- requirements for releasing cranes during erection that differ from the requirements of this Item or those shown on the plans.

If site conditions differ from those assumed for these drawings, revise the drawings to reflect the actual conditions before continuing the erection work.

b. Shop Drawings. Before fabrication, prepare and submit shop drawings for each detail of the general plans requiring the use of structural steel, forgings, wrought iron, or castings.

(1) Bridge Structures. Unless otherwise approved, prepare drawings in accordance with AASHTO/NSBA Steel Bridge Collaboration G1.3, “Shop Detail Drawing Presentation.” Print a bill of material on each sheet, including the Charpy V-Notch (CVN) and fracture-critical requirements, if any, for each piece. Indicate joint details on shop drawings for all welds. Indicate fracture-critical areas of members.

Show a title block in the lower right corner including:

- project identification data including federal and state project numbers,
- sheet numbering for the shop drawings,
- name of the structure or stream,
- name of the fabricator or supplier, and
- name of the Contractor.

Submit 7 copies of shop drawings to the Engineer. Submit an additional copy if the owner is a non-Department entity such as a railroad or a municipal or turnpike authority, and another copy if the designer is a private consultant. The Engineer may require additional sets.

(2) **Non-Bridge Structures.** Prepare clear and legible shop drawings for the complete assembly on sheets 11 × 17 in. Full-size drawings may be reduced to half-scale size if they are clear and legible. At the left end, provide a 1-1/2-in. margin, with the other margins 1/2 in. wide. Indicate joint details on shop drawings for all welds. Provide a title block on each sheet in the lower right corner with the following information:

- sheet index data shown on the lower right corner of the project plans,
- sheet numbering for the shop drawings,
- name of the fabricator, and
- name of the Contractor.

Furnish 7 copies of completed shop drawings to the Engineer.

7. **Welding and Fabrication Procedures.**

- a. **Welding Procedures.** Before fabrication begins, submit welding procedures in accordance with the applicable AWS code to the Construction Division, Materials and Pavements Section, and notify the Engineer which procedures will be used for each joint or joint type.

Post the approved welding procedure specification for the welding being performed on each welding machine, or use another approved method of ensuring that the welder has access to the procedure information at all times.

- b. **Fabrication Procedures.** When primary bridge members are fabricated by welding or bolting, submit a fabrication procedure before fabrication begins. The fabrication procedure must include details required by S2.1 as well as:

- special processes such as planing or facing,
- details of heat treating and heat straightening procedures, and
- any other information required by the Engineer.

Have a fabrication procedure approved for each type of structure (rolled beams with welded or bolted splices, plate girders with welded or bolted splices, tub girders with welded or bolted splices, box girders, plate girder bents, railroad thru-girders and plate girders, truss bridges, orthotropic deck segments, or other major bridge structure types) before starting fabrication.

8. **Submerged-Arc Welding (SAW).** Provide equipment with automatic guidance capable of maintaining the position of the arc and controlling the speed of travel so that, when once set by the operator, little manipulation is needed. Small adjustments to compensate for acceptable plate waviness, acceptable tilt of flange, etc. will be permitted. Do not use hand-held semiautomatic SAW for welding bridge members unless altered to provide automatic guidance or otherwise approved.
9. **Inspection.** Provide approved facilities, materials, and equipment required for inspection in accordance with Article 6.5, "Plant Inspection and Testing," and Item 504, "Field Office and Laboratory." Unless otherwise approved, provide an office meeting the requirements of Section 504.2.B.3, "Type C Structure (Field Office)," except that only 200 sq. ft. are required if fewer than 3 inspectors will be assigned to the facility. Provide desks, a layout table, a plan rack, and Internet service in accordance with DMS-10101, "Computer Equipment." Maintain the office and equipment so that it will continue to function properly for the intended use.

Provide the Inspector with the helpers and equipment needed to move material to allow inspection. QC is solely the responsibility of the Contractor. The Contractor must have a QC staff qualified in accordance with the applicable AWS code. The QC staff must provide inspection of all materials and workmanship prior to inspection by the Department.

When structural steel is fabricated outside of the contiguous 48 states, the additional cost of inspection will be in accordance with Article 6.4, "Sampling, Testing, and Inspection."

10. **Documentation.** Before beginning fabrication, provide a completed Material Statement (Form D-9-USA-1) with supporting documentation (such as mill test reports), issued by the producing mill and verified by qualified personnel. The Department will supply blank forms without charge. Ensure that the documentation legibly reflects all information required by the applicable ASTM specifications.

As material is shipped or placed in approved storage, provide a copy of the shipping or storage invoice that reflects:

- member piece mark identification and calculated weight per piece from the contract drawings,
- number of pieces shipped or in storage,

- total calculated weight for each invoice per bid item, and
- the unique identification number of the shipping or storage invoice.

The acceptance of material or finished members by the Inspector will not prohibit subsequent rejection if the material or members are found to be damaged or defective. Replace rejected material promptly.

- 11. Material Identification.** Assembly-mark individual pieces and issue cutting instructions to the shop using a system that will maintain identity of the original piece.

Identify structural steel by standard and grade of steel. Also differentiate between material toughness requirements (CVN, fracture-critical) as well as any other special physical requirements. In addition, identify structural steel for primary members by mill identification numbers (heat numbers). Use an approved identification system. Use either paint or low-stress stencils to make identification markings on the metal. Mark the material as soon as it enters the shop and carry the markings on all pieces through final fabrication. Transfer the markings before cutting steel for primary members of bridge structures into smaller pieces. Loss of identification marking on any piece, with no other positive identification, or loss of heat number identification on any primary member piece will render the piece unacceptable for use. Unidentifiable material may be approved for use after testing to establish acceptability to the satisfaction of the Engineer. Have testing performed by an approved testing facility, and have results signed and sealed by a licensed professional engineer.

B. Welding.

1. Details.

- a. Rolled Edges.** Trim plates with rolled edges used for webs by thermal cutting.
- b. Weld Tabs.** Use weld tabs at least 2 in. long for manual and semi-automatic processes and at least 3 in. long for automatic processes, and in all cases at least as long as the thickness of the material being welded. Use longer weld tabs as required for satisfactory work.
- c. Weld Termination.** Terminate fillet welds approximately 1/4 in. from the end of the attachment except for galvanized structures and flange-to-web welds, for which the fillet weld

441.3 to 441.3

must run the full length of the attachment unless otherwise noted on the plans.

- d. **No-Paint Areas at Field-Welded Connections.** Keep surfaces within 4 in. of groove welds or within 2 in. of fillet welds free from shop paint.
- e. **Galvanized Assemblies.** Completely seal all edges of tightly contacting surfaces by welding before galvanizing.

2. Shop Splices.

- a. **Shop Splice Locations.** Keep at least 6 in. between shop splices and stiffeners or crossframes and at least 6 in. between web and flange shop splices. Do not add optional splices to plates shown on the plans as 40 ft. long or shorter unless necessary to obtain the required geometry or otherwise approved. Obtain approval for shop splices added after shop drawings are approved.

(1) **Continuous Multiple-Span Structures.** Unless otherwise shown on the plans or approved, do not locate tension flange splices within 0.05S of an interior bearing, within 0.10S of the centerline of an interior span, or between 0.30S and 0.50S from an end bearing, where S is the span length between centers of bearings.

(2) **Single-Span Structures.** Unless otherwise shown on the plans or approved, do not locate tension flange splices within 0.10S of the centerline of the span.

- b. **Grinding Splice Welds.** Grind shop groove welds in flange plates smooth and flush with the base metal on all surfaces whether the joined parts are of equal thickness or of unequal thickness. Grind so that the finished grinding marks run in the direction of stress, and keep the metal below the blue brittle range (below 350°F). Groove welds in web plates, except at locations of intersecting welds, need not be ground unless shown on the plans except as required to meet AWS welding code requirements.

- 3. **Joint Restraint.** Never restrain a joint on both sides when welding.

4. Stiffener Installation.

- a. **Flange Tilt.** Members must meet combined tilt and warpage tolerances before the installation of stiffeners. Cut stiffeners to

fit acceptable flange tilt and cupping. Minor jacking or hammering that does not permanently deform the material will be permitted.

- b. Stiffeners Near Field Splices.** Tack-weld intermediate stiffeners within 12 in. of a welded field splice point in the shop. Weld the stiffeners in the field in accordance with Item 448, “Structural Field Welding,” after the splice is made.
- 5. Nondestructive Examination (NDE).** Perform magnetic particle testing (MT), radiographic testing (RT), and ultrasonic testing (UT) at the Contractor’s expense as specified in D1.5 for bridge structures and D1.1 for all other welding. The Engineer will periodically witness, examine, verify, and interpret NDE. Additional welds may be designated for NDE on the plans. Retest repaired groove welds per the applicable AWS code after repairs are made and have cooled to ambient temperature. Complete NDE and repairs before assembly of parts into a member but after any heat-correction of weld distortion.
 - a. Radiographic Testing.** Radiographs must have a density of at least 2.5 and at most 3.5, as confirmed by a radiographer. The density in any single radiograph showing a continuous area of constant thickness must not vary in this area by more than 0.5. Use only ASTM System Class I radiographic film as described in ASTM E 1815. Use low-stress stencils or other acceptable means to make radiograph and location identification marks on the steel. The Engineer will examine and interpret all results of RT.
 - b. Ultrasonic Testing.** Have UT equipment calibrated yearly by an authorized representative of the equipment manufacturer or by an approved testing laboratory.
 - c. Magnetic Particle Testing.** Orient the prod or pole position normal or parallel to the weld unless otherwise approved. When using the yoke method, use half-wave rectified DC unless otherwise approved.
 - d. Extra-high Strength Steel.** For shop welds on steel that has a nominal yield strength over 70,000 psi, perform RT on all flange and web splices in addition to any requirements of the applicable AWS code. Wait at least 48 hours after completing these welds before inspecting them.

- 6. Testing of Galvanized Weldments.** If problems develop during galvanizing of welded material, the Engineer may require a test of the compatibility of the combined galvanizing and welding procedures in accordance with this Section and may require modification of one or both of the galvanizing and welding procedures.

If testing is required, prepare a test specimen with a minimum length of 12 in. using the same base material, having the same joint configuration, and using the welding procedure proposed for production work. Clean and galvanize this test specimen using the same conditions and procedure that will be applied to the production galvanizing.

After galvanizing, examine the test specimen. There must be no evidence of excessive buildup of zinc coating over the weld area. Excessive zinc coating buildup will require modification of the galvanizing procedure.

Remove the zinc from the weld area of the test specimen in accordance with ASTM A 90, and visually examine the weld area. There must be no evidence of loss of weld metal or any deterioration of the base metal due to the galvanizing or welding procedure. If there is evidence of deterioration or loss of weld metal, modify the galvanizing or welding procedure as required and run a satisfactory retest on the modified procedures before production work. Report procedures and results on the galvanized weldment worksheet provided by the Department.

- C. Bolt Holes.** Detail holes on shop drawings 1/16 in. larger in diameter than the nominal bolt size shown on the plans unless another hole size is shown on the plans.

Thoroughly clean the contact surfaces of connection parts in accordance with Section 447.4.B, "General," before assembling them for hole fabrication. Make holes in primary members full-size (by reaming from a subsize hole, drilling full-size, or punching full-size where permissible) only in assembly unless otherwise approved.

Ream and drill with twist drills guided by mechanical means unless otherwise approved. If subpunching holes, punch them at least 3/16 in. smaller than the nominal bolt size. When numerically controlled (N/C) equipment is used, submit for approval the proposed procedures to accomplish the work from initial drilling or punching through check assembly. Use thermal cutting for holes only with permission of the Engineer. Permission for thermal cutting is not required for making

slotted holes, when slotted holes are shown on the plans, by drilling or punching two holes and then thermally cutting the straight portion between them. Perform all thermal cutting in accordance with Section 441.3.E.1, "Thermal Cutting."

Slightly conical holes that naturally result from punching operations are acceptable provided they do not exceed the tolerances of S2.1. The tolerance for anchor bolt hole diameter for bridge bearing assemblies is +1/8 in., -0.

D. Dimensional Tolerances. Meet tolerances of the applicable AWS specifications and S2.1 except as modified in this Section.

- 1. Rolled Sections.** Use ASTM A 6 mill tolerances for rolled sections, except that D1.5 camber tolerances apply to rolled sections with a specified camber.
- 2. Flange Straightness.** Ensure that flanges of completed girders are free of kinks, short bends, and waviness that depart from straightness or the specified camber by more than 1/8 in. in any 10 ft. along the flange. Rolled material must meet this straightness requirement before being laid off or worked. Plates must meet this requirement before assembly into a member. After straightening a bend or buckle, inspect the surface of the metal for evidence of fracture. The Engineer may require nondestructive testing.
- 3. Alignment of Deep Webs in Welded Field Connections.** For girders 48 in. deep or deeper, the webs may be slightly restrained while checking compliance with tolerances of S2.1. In the unrestrained condition, webs 48 in. deep or deeper must meet the tolerances of Table 1. Girders under 48 in. deep must meet the alignment tolerances of S2.1.

Table 1
Web Alignment Tolerances for Deep Girders

Web Depth (in.)	Maximum Web Misalignment (in.)
48	1/16
60	1/8
72	1/4
84	5/16
96	5/16
108	3/8
120	7/16
132	7/16
144	1/2

4. **Bearings.** Correct bearing areas of shoes, beams, and girders using heat, external pressure, or both. Grind or mill only if the actual thickness of the member is not reduced by more than 1/16 in. below the required thickness.
- a. **I-Beams, Plate Girders, and Tub Girders.** The plane of the bearing area of beams and girders must be perpendicular to the vertical axis of the member within 1/16 in. in any 24 in.
- b. **Closed Box Girders.** Meet these tolerances:
- The plane of the bearing areas of the box girder is perpendicular to the vertical axis of the girder within 1/16 in. across any horizontal dimension of the bearing.
 - The planes of the beam supports on the box girder are true to the vertical axis of the supported beams or girders to 1/16 in. in any 24 in.
- In the shop, verify the plane of all bearing areas with the box placed on its bearings to field grade, using an approved process for verification.
- c. **Shoes.** Meet these tolerances:
- The top bolster has the center 75% of the long dimension (transverse to the girder) true to 1/32 in., with the remainder true to 1/16 in., and is true to 1/32 in. across its entire width in the short dimension (longitudinal to the girder).
 - The bottom bolster is true to 1/16 in. across its diagonals.
5. **End Connection Angles.** For floor beams and girders with end connection angles, the tolerance for the length back to back of

connection angles is $\pm 1/32$ in. If end connections are faced, do not reduce the finished thickness of the angles below that shown on the shop drawings.

E. Other Fabrication Processes.

1. **Thermal Cutting.** Use a mechanical guide to obtain a true profile. Hand-cut only where approved. Hand-cutting of radii for beam copes, weld access holes, and width transitions is permitted if acceptable profile and finish are produced by grinding. Provide a surface finish on thermal-cut surfaces, including holes, in accordance with D1.5 requirements for base metal preparation. Obtain approval before using other cutting processes.
 2. **Oxygen-Gouging.** Do not oxygen-gouge ASTM A 588 or A 709 Gr. 50W steel or material with nominal yield strength over 70 ksi.
 3. **Annealing and Normalizing.** Complete all annealing or normalizing (as defined in ASTM A 941) before finished machining, boring, and straightening. Maintain the temperature uniformly throughout the furnace during heating and cooling so that the range of temperatures at all points on the member is no greater than 100°F.
 4. **Machining.** Machine the surfaces of expansion bearings so that the travel direction of the tool is in the direction of expansion.
 5. **Camber.** Complete cambering in accordance with S2.1 before any heat-curving.
 6. **Heat Curving.** Heat-curve in accordance with S2.1. The methods in the AASHTO bridge construction specifications are recommended. Attach cover plates to rolled beams before heat-curving only if the total thickness of one flange and cover plate is less than 2-1/2 in. and the radius of curvature is greater than 1,000 ft. For other rolled beams, attach cover plates only after heat-curving is completed. Locate and attach connection plates, diaphragm stiffeners, and bearing stiffeners after curving, unless girder shrinkage is accounted for.
 7. **Bending of Quenched and Tempered Steels.** The cold-bending radius limitations for HPS 70W in S2.1 apply to all quenched and tempered steels.
- F. Nonconformance Reports (NCRs).** When the requirements of this Item are not met, submit an NCR to the Engineer for approval. Include on the NCR:

441.3 to 441.3

- date of submittal, nonconformance report number, and IFM number (when applicable);
- project information (county; control, section, and job numbers; project number; shop order number; structure name, etc.);
- member identification (member number, or piece or erection mark);
- description of problem including references to sections of specifications not met;
- explanation of why the problem occurred and plan for preventing future occurrences (if applicable);
- detailed description (including drawings) of proposed solution including a repair proposal; and
- diagrams detailing all pertinent dimensions and locations on relevant sections of shop drawings, including title blocks.

Do not begin repairs before approval is received. Perform all repair work in strict compliance with the approved repair procedure.

G. Shop Assembly.

1. **General Shop Assembly.** Shop-assemble field connections of primary members of trusses, arches, continuous beam spans, bents, towers (each face), plate girders, field connections of floor beams and stringers (including for railroad structures), field-bolted diaphragms for curved plate girders and railroad underpasses, and rigid frames. Complete fabrication, welding (except for shear studs), and field splice preparation before members are removed from shop assembly. Obtain approval for any deviation from this procedure. The Contractor is responsible for accurate geometry.

Use a method and details of preassembly consistent with the erection procedure shown on the erection plans and camber diagrams. The sequence of assembly may start from any location in the structure and proceed in one or both directions. An approved method of sequential geometry control is required unless the full length of the structure is assembled.

Verify by shop assembly the fit of all bolted and welded field connections between bent cap girders and plate girders or between plate girders and floor beams.

Do not measure horizontal curvature and vertical camber for final acceptance until all welding and heating operations are completed and the steel has cooled to a uniform temperature. Check horizontal curvature and vertical camber in a no-load condition.

2. **Bolted Field Connections.** Each shop assembly, including camber, alignment, accuracy of holes, and fit of milled joints, must be approved before the assembly is dismantled.

Assemble with milled ends of compression members in full bearing. Assemble non-bearing connections to the specified gap. Ream all subsize holes to the specified size while the connections are assembled, or drill full size while the connections are assembled. Notify the Engineer before shipping if fill plates or shims are added. Adding or increasing the thickness of shims or fill plates in bearing connections requires approval. Use drift pins and snug-tight bolts during the drilling process to ensure that all planes of the connection (webs and flanges) can be assembled simultaneously. Do not use tack welds to secure plates while drilling.

If parts are not completely bolted in the shop, secure them by temporary bolts to prevent damage in shipment and handling. Never use tack welds in place of temporary bolts.

Match-mark connecting parts in field connections using low-stress stencils in accordance with the diagram in the erection drawings.

3. **Welded Field Connections.** Mill or grind bevels for groove welds. Do not cut into the web when cutting the flange bevel adjacent to the web. End preparation, backing, and tolerances for single-V groove welds for framing beams or girders must conform to the applicable AWS code unless otherwise shown on the plans.

In the shop, prepare ends of beams or girders to be field-welded taking into account their relative positions in the finished structure due to grade, camber, and curvature. Completely shop-assemble and check each splice. While the splice is assembled, match-mark it with low-stress stencils in accordance with the diagram in the erection drawings.

H. Finish and Painting.

1. **Shop Painting.** On new steel items to be painted (except for the coatings on box and tub girder interiors), grind corners that are sharp or that form essentially 90° angles to an approximately 1/16-in. flat surface before blast cleaning. (A corner is the intersection of two plane faces.) This requirement does not apply to punched or drilled holes. Apply shop paint in accordance with Item 446, "Cleaning and Painting Steel." Do not omit shop paint to preserve original markings.

441.3 to 441.3

2. **Bearing and Faying Surfaces.** Clean and prepare all bearing and faying surfaces of bolted connections, including those in railroad structures, in accordance with Item 447, “Structural Bolting,” before shipment.
3. **Girder Interiors.** Paint the inside of all box and tub girders in accordance with applicable provisions of Item 446, “Cleaning and Painting Steel.”
4. **Weathering Steel.** Provide an SSPC-SP 6 blast in the shop to all fascia surfaces of unpainted weathering steel beams. Fascia surfaces include:
 - exterior sides of outermost webs and undersides of bottom flanges of plate girders and rolled beams,
 - all outer surfaces of tub girders and box girders,
 - all surfaces of truss members,
 - webs and undersides of bottom flanges of plate diaphragms,
 - bottom surfaces of floor beams, and
 - any other surfaces designated as “fascia” on the plans.

Do not mark fascia surfaces. Use one of the following methods as soon as possible to remove any markings or any other foreign material that adheres to the steel during fabrication and that could inhibit the formation of oxide film:

- SSPC-SP 1, “Solvent Cleaning”
- SSPC-SP 2, “Hand Tool Cleaning”
- SSPC-SP 3, “Power Tool Cleaning”
- SSPC-SP 7, “Brush-off Blast Cleaning.”

Do not use acids to remove stains or scales. Feather out touched-up areas over several feet.

5. **Machined Surfaces.** Clean and coat machine-finished surfaces that are in sliding contact, particularly pins and pinholes, with a non-drying, water-repellent grease-type material containing rust-inhibitive compounds. Ensure that the coating material contains no ingredients that might damage the steel. Protect machined surfaces from abrasive blasting.
- I. **Handling and Storage of Materials.** Prevent damage when storing or handling girders or other materials. If damage to material is caused by handling devices or improper storage, remove or repair the material by acceptable means in accordance with ASTM A 6 and the applicable AWS code.

Place stored materials on skids or acceptable dunnage above the ground. Keep materials clean. Shore girders and beams to keep them upright and free of standing water. Place support skids close enough to prevent excessive deflection in long members such as columns. Do not stack completed girders or beams at the jobsite.

Protect structural steel from salt water or other corrosive environments during storage and transit.

- J. Marking and Shipping.** Mark all structural members in accordance with the erection drawings. If a surface is painted, make the marks over the paint. Do not use impact-applied stencils to mark painted surfaces.

Mark the weight directly on all members weighing more than 3 tons.

Keep material clean and free from injury during loading, transportation, unloading, and storage. Pack bolts of each length and diameter, and loose nuts or washers of each size, separately and ship them in boxes, crates, kegs, or barrels. Plainly mark a list and description of the contents on the outside of each package.

K. Field Erection.

- 1. Methods and Equipment.** Do not tack-weld parts instead of using erection bolts. Do not tack-weld parts to hold them in place for bolting. Provide falsework, tools, machinery, and appliances, including drift pins and erection bolts. Provide enough drift pins, 1/32 in. larger than the connection bolts, to fill at least 1/4 of the bolt holes for primary connections. Use erection bolts of the same diameter as the connection bolts.

Securely tie, brace, or shore steel beams or girders immediately after erection as shown on the plans and the erection drawings. Maintain this bracing or shoring until the diaphragms are in place. Protect railroad or roadway traffic that may be beneath erected girders or beams from falling objects during erection of the members and diaphragms, placement of the deck concrete, and erection and removal of forms. Use nets or flooring with openings no larger than 1 in. for this protection.

- 2. Falsework.** Design and construct falsework for the anticipated loads, including wind, and properly maintain this falsework.
- 3. Handling and Assembly.** Accurately assemble all parts as shown on the plans and the approved shop drawings. Verify match-marks. Handle parts carefully to prevent bending or other damage. Do not hammer if doing so damages or distorts members. Do not weld any

441.3 to 441.3

member for transportation or erection unless noted on the plans or approved by the Engineer.

- a. **Welded Connections.** Before releasing the erection cranes, weld flange splices to 50% of their thickness and meet the minimum erection bracing and support requirements shown on the plans and on the submitted erection plans. Field-weld in accordance with Item 448, “Structural Field Welding.”
- b. **Bolted Connections.** Before releasing the erection cranes:
 - install 50% of the bolts in the top and bottom flanges and the web with all nuts finger-tight,
 - meet the minimum erection bracing and support requirements shown on the plans and on the submitted erection plans, and
 - for tub girders, install top lateral bracing across the connection and fully tension the bolts connecting the bracing to the top flanges.

Install high-strength bolts, including erection bolts, in accordance with Item 447, “Structural Bolting.” Clean bearing and faying surfaces for bolted connections in accordance with Item 447. Clean the areas of the outside ply under washers, nuts, and bolt heads before bolt installation. Ensure that the required faying surface condition is present at the time of bolting.

4. **Misfits.** Correct minor misfits. Ream no more than 10% of the holes in a plate connection (flange or web), and ensure that no single hole is more than 1/8 in. larger than the nominal bolt diameter. Submit proposed correction methods for members with defects that exceed these limits or that prevent the proper assembly of parts. Straighten structural members in accordance with S2.1. Make all corrections in the presence of the Engineer at no expense to the Department. Do not remove and reweld gusset plates without approval.
5. **Bearing and Anchorage Devices.** Place all bearing devices such as elastomeric pads, castings, bearing plates, or shoes on properly finished bearing areas with full and even bearing on the concrete. Place metallic bearing devices on 1/4-in.-thick preformed fabric pads manufactured in accordance with Item 434, “Elastomeric Bridge Bearings,” to the dimensions shown on the plans. Provide holes in the pad that are no more than 1/4 in. larger than the bolt diameter.

When the concrete bearing area has been placed below grade, build it up to the correct elevation using mortar that meets Item 420, "Concrete Structures," and provide adequate curing. For buildups between 1/8 in. and 3/8 in. thick, use only mortar. If the bearing area must be raised more than 3/8 in., use galvanized steel shims or other approved shim materials in conjunction with mortar.

Provide at least 75% contact of flange to shoe with no separation greater than 1/32 in. for beams and girders. Make corrections using heat or pressure in accordance with S2.1, or with galvanized shims. Correct small irregularities by grinding.

Provide at least 85% contact between the rocker plate and the base plate. Adjust the location of slotted holes in expansion bearings for the prevailing temperature. Adjust the nuts on the anchor bolts at the expansion ends of spans to permit free movement of the span. Provide lock nuts or burr the threads.

Remove all foreign matter from sliding or machine-finished surfaces before placing them in the structure.

Restore distorted bearing pads or expansion bearings to an equivalent 70°F position after completion of all welded or bolted splices, using an approved method of relieving the load on the bearing devices.

6. **Erecting Forms.** Do not erect forms until all welding or bolting is complete and the unit is positioned and properly set on the bearing unless otherwise noted on the plans.
7. **Field Finish.** Paint in accordance with Item 446, "Cleaning and Painting Steel." For weathering steel that will remain unpainted, after all welding and slab concrete placement has been completed, restore the steel to a uniform appearance by solvent cleaning, hand cleaning, power brush, or blast cleaning. As soon as possible, remove from all unpainted weathering steel fascia surfaces (as defined in Section 441.3.H.4, "Weathering Steel") any foreign material, including markings, that adheres to the steel and could inhibit formation of oxide film. Feather out touched-up areas over several feet. Do not use acids to remove stains or scales.

441.4. Measurement and Payment. The work performed, materials furnished, equipment, labor, tools, and incidentals will not be measured or paid for directly but will be subsidiary to pertinent Items.

ITEM 442
METAL FOR STRUCTURES

442.1. Description. Provide structural steel, high-strength bolts, forgings, steel castings, iron castings, wrought iron, steel pipe and tubing, aluminum castings and tubing, or other metals used in structures, except reinforcing steel and metal culvert pipe.

442.2. Materials. Furnish mill test reports (MTRs), supplemental test documentation, and certifications required by this and other pertinent Items.

A. Structural Steel. The Engineer may sample and test steel in accordance with ASTM A 370.

1. Bridge Structures. Provide the grade of ASTM A 709 steel shown on the plans. Grade 50W, 50S, or HPS 50W may be substituted for Grade 50 at no additional cost to the Department. For tension members and components, provide steel that meets supplemental requirement S83, “Non-Fracture-Critical, T, Material; Toughness Tests and Marking,” for non-fracture-critical applications and S84, “Fracture-Critical, F, Material; Toughness Testing and Marking,” for fracture-critical applications. If no AASHTO temperature zone is shown on the plans, use Zone 1.

2. Non-Bridge Structures.

a. Steel Classifications. Provide the types and grades of steel listed in this Section unless otherwise shown on the plans.

(1) Carbon Steel. Meet ASTM A 36

(2) Low-Alloy Steel. Meet the requirements of one of the following standards:

- ASTM A 572 Grade 50 or 55;
- ASTM A 588;
- ASTM A 709 Grade 50, 50S, 50W, or HPS 50W; or
- ASTM A 992.

Specify ASTM A 6 supplemental requirement S18, “Maximum Tensile Strength,” for material used for sign, signal, and luminaire supports.

b. Impact Testing. Tension members and components of the following structure types, if more than 1/2 in. thick, and other members designated on the plans must meet the Charpy V-notch (CVN) requirements of Table 1:

- base plates for roadway illumination assemblies, traffic signal pole assemblies, high mast illumination poles, and overhead sign supports;
- arm mounting plates and clamp-on plates for traffic signal pole assemblies;
- pole shafts, ground sleeves, and handhole frames for high mast illumination poles; and
- W-columns, tower pipes, multiple-sided shafts, tower pipe and multiple-sided shaft connection plates, chord angles, chord splice plates or angles, and truss bearing angles for overhead sign supports.

Table 1
CVN Requirements for Non-Bridge Steel

Material	Thickness	Minimum CVN Toughness
ASTM A 36, A 53, A 242, A 500, A 501, A 709 Gr. 36, any other steel with minimum specified yield point below 40 ksi	up to 4"	15 ft.-lb. at 70°F
ASTM A 572 ¹ , A 588 ¹ , A 633 ¹ , any other steel with minimum specified yield point between 40 and 65 ksi, inclusive	up to 2"	15 ft.-lb. at 70°F
	over 2" to 4", mechanically fastened	15 ft.-lb. at 70°F
	over 2" to 4", welded	20 ft.-lb. at 70°F
Any steel with minimum specified yield point over 65 ksi and under 90 ksi ²	up to 2-1/2"	20 ft.-lb. at 50°F
	over 2-1/2" to 4", mechanically fastened	20 ft.-lb. at 50°F
	over 2-1/2" to 4", welded	25 ft.-lb. at 50°F

1. If the yield point of the material given on the MTR exceeds 65 ksi, reduce the testing temperature by 15°F for each 10-ksi increment or fraction thereof above 65 ksi.

2. If the yield point of the material given on the MTR exceeds 85 ksi, reduce the testing temperature by 15°F for each 10-ksi increment or fraction thereof above 85 ksi.

Use the (H) frequency of testing for material with minimum specified yield point up to and including 50 ksi. Use the (P) frequency of testing for material with minimum specified yield point over 50 ksi. Ensure that steel is sampled and tested in accordance with ASTM A 673.

3. Other Components.

- a. Miscellaneous Bridge Components.** For members such as steel bearing components not bid under other Items, steel diaphragms for use with concrete bridges, armor joints, and finger joints, provide steel that meets ASTM A 36, A 709 Grade 36, or A 500 Grade B unless otherwise shown on the plans.
- b. Shear Connectors and Anchors.** For stud shear connectors, slab anchors, and anchors on armor joints and finger joints, provide cold-drawn bars that meet the requirements of ASTM A 108, Grade 1010, 1015, 1018, or 1020, either semi-killed or killed, and that have the tensile properties given in Table 2 after drawing or finishing. Determine tensile properties in accordance with ASTM A 370.

**Table 2
Minimum Tensile Properties for Bar Stock**

Tensile strength	60 ksi
Yield strength	50 ksi
Elongation	20% (2")
Reduction of area	50%

Provide certification from the manufacturer that the studs or anchors as delivered have the required material properties.

- c. Fasteners.** Provide high-strength bolts that meet ASTM A 325 or A 490 as shown on the plans. The Department may sample high-strength bolts, nuts, and washers for structural connections in accordance with Tex-719-I.

Follow the requirements of Item 447, “Structural Bolting,” for tests, test reports, and supplemental requirements for high-strength bolts, nuts, and washers.

When ASTM A 325 or A 490 bolts are not shown on the plans, use bolts that meet ASTM A 307 and nuts that meet ASTM A 563.

- d. Slip-resistant Deck Plates.** For deck plates, furnish steel that meets ASTM A 786 and one of A 242, A 588, or A 709 Gr. 50W. State the type and trade name of material to be used on the shop drawings.

- e. **Rail Posts.** Provide material for rail posts that meets ASTM A 36 or ASTM A 709 Grade 36 unless otherwise shown on the plans.
- B. **Steel Forgings.** Provide steel forgings for pins, rollers, trunnions, or other forged parts that meet ASTM A 668, Class C, D, F or G, as shown on the plans. For pins 4 in. or smaller in diameter for non-railroad structures, material that meets ASTM A 108, Grades 1016 to 1030, with a minimum yield strength of 36 ksi, may be used instead.
- C. **Steel Castings.** Provide steel castings that meet ASTM A 27, Grade 70-36.
- D. **Iron Castings.** Provide iron castings that are true to pattern in form and dimensions; are free from pouring faults, sponginess, cracks, blow holes, and other defects in positions affecting their strength and value for the service intended; and meet the standards shown in Table 3.

Table 3
Standards for Iron Castings

Casting Material	ASTM Standard	Grade or Class
Gray iron	A 48	35B
Malleable iron	A 47	32510
Ductile iron	A 536	65-45-12

- E. **Steel Tubing.** Provide steel tubing that meets ASTM A 500, Grade B unless otherwise shown on the plans. Tubing that meets API Standard 5L, Grade X52 may be used if produced by a mill listed in the standard API specifications as authorized to produce pipe with the API monogram. Hydrostatic tests are not required for API 5L steel, and instead of a mill test report the manufacturer may furnish a certificate for each lot or shipment certifying that the tubing meets the requirements of this Section.
- F. **Pipe Rail.** “Pipe” includes special extruded and bent shapes. Provide pipe that is rolled, extruded, or cold-pressed from a round pipe or flat plate, and of the section shown on the plans.

If pipe is cold-pressed, ensure that the design of the press and dies results in a pipe of uniform section free from die marks. After the pipe has been formed to the required section, cut it to the lengths required. Make the end cuts and notches at the angles to the axis of the pipe required to produce vertical end faces and plumb posts when required by the plans. Provide a neat and workmanlike finish when cutting and notching pipe.

442.3 to 442.4

- G. Aluminum.** Unless otherwise shown on the plans, provide aluminum materials that meet the standards shown in Table 4.

Table 4
Aluminum Standards

Material	ASTM Standard	Alloy-Temper
Castings	B 108	A444.0-T4
Extrusions	B 221	6061-T6
Sheet or plate	B 209	6061-T6

When testing is required, cut test specimens from castings from the lower 14 in. of the tension flange but not at the junction of the rib or base. Flatten the curved surfaces before machining. Provide standard test specimens in conformance with ASTM E 8.

442.3. Construction.

- A. Fabrication, Erection, and Painting.** Fabricate, weld, and erect structural metal in accordance with Item 441, “Steel Structures”; Item 447, “Structural Bolting”; Item 448, “Structural Field Welding”; and the applicable AWS welding code. Paint in accordance with Item 446, “Cleaning and Painting Steel.” Aluminum or galvanized steel members do not require painting unless otherwise shown on the plans.
- B. Galvanizing.** Galvanize fabricated steel items, steel or iron castings, bolts, nuts, screws, washers, and other miscellaneous hardware in accordance with Item 445, “Galvanizing.” Galvanizing is not required unless specified.

442.4. Measurement. This Item will be measured by the pound of structural metal furnished and placed in a complete structure not including the weight of erection bolts, paint, or weld metal.

This is a plans quantity measurement Item. The quantity to be paid is the quantity shown in the proposal unless modified by Article 9.2, “Plans Quantity Measurement.” Additional measurements or calculations will be made if adjustments of quantities are required.

The maximum percent variance from the plans quantity will be as given in Table 5.

Table 5
Percent Variance

Quantity	Variance
Over 1,000,000 lb.	1/2%
100,000 through 1,000,000 lb.	1%
Under 100,000 lb.	1-1/2%

If the Engineer approves requests for increases in sizes or weights of members, measurement will be made on the sizes or weights shown on the plans.

Castings, bearing plates, anchor bolts, drains, deck plates, armor joints, finger joints, and other metal for which no separate measurement is specified will be included in the total quantity of structural steel.

The weights of rolled materials (such as structural shapes and plate) will be computed on the basis of nominal weights and dimensions using measurements shown on the plans. Deductions will not be made for material that is removed for copes, clips, planing, or weld preparation. The weight of castings will be computed from the dimensions shown on the approved shop drawings. Shoes will be measured by the weights shown on the plans.

Weight of high-strength fasteners will be based on Table 6. Weight of other metal will be based on Table 7.

Splices will be measured as follows:

- No additional weight will be allowed for weld metal in a welded splice.
- Where a bolted splice is permitted as an alternate for a welded splice, measurement will be made on the basis of a welded splice.
- Where a bolted splice is required, the weight of the splice material, bolt heads, washers, and nuts will be measured with no deduction for holes.

Table 6
Pay Weight for High-Strength Fasteners, Pounds per Hundred Units

Diameter	Item		
	Bolt heads	Nuts	Washers
3/4"	15	19	4.8
7/8"	23	30	7.0
1"	32	43	9.4
1-1/8"	45	59	11
1-1/4"	64	79	14

Table 7
Pay Weight for Metals

Material	Weight (lb./cu. in)
Steel	0.2836
Cast iron	0.2604
Wrought iron	0.2777

442.5. Payment. The work performed and materials furnished in accordance with this Item and measured as provided under “Measurement” will be paid for at the unit price bid for “Structural Steel” of the type (Rolled Beam, Plate Girder, Tub Girder, Box Girder, Miscellaneous) specified. This price is full compensation for materials, fabrication, transportation, erection, paint, painting, galvanizing, equipment, tools, labor, and incidentals.

ITEM 445
GALVANIZING

445.1. Description. Galvanize or repair galvanizing on metal items.

445.2. Materials. Provide galvanized metal items that meet the standards in Table 1.

Table 1
Galvanizing Standards

Item	Standard
Fabricated items, rolled, pressed or forged steel shapes, plates, pipes, tubular items, and bars	ASTM A 123
Steel or iron castings	ASTM A 153, Class A
Bolts, nuts, screws, washers, and other miscellaneous hardware	ASTM A 153, Class C or D or ASTM B 695, Class 50
Miscellaneous fasteners	ASTM B 633, Class Fe/Zn 8
Rail elements for metal beam guard fence or bridge railing	AASHTO M 180
Permanent metal deck forms, supporting angles and incidental items	ASTM A 653, Coating Designation G165

445.3. Construction.

- A. General.** If fabricated members or assemblies are required to be hot-dip galvanized, provide for proper filling, venting, and draining during cleaning and galvanizing. Provide drain holes or slots as required, except where prohibited by the plans. If assembling tapered members using slip-joint splices, drain to the small end of the section. Ensure that cleaning and galvanizing do not produce hydrogen embrittlement.

Before galvanizing material 1/4 in. or greater in thickness:

- remove all sharp burrs and
- chamfer to approximately 1/16 in. all edges exposed to electrical conductors or to human activity.

If painting is specified on galvanized materials, paint in accordance with Item 446, "Cleaning and Painting Steel." Do not water-quench or chromate-quench galvanized surfaces to be painted.

- B. Galvanizing Weldments.** If problems develop during galvanizing of welded material, the Engineer may require a test of the compatibility of the combined galvanizing and welding procedures in accordance with Section 441.3.B.6, "Testing of Galvanized Weldments," and may require modification of one or both of the galvanizing and welding procedures.
- C. Workmanship.**
1. **Coverage.** Bare spots at most 1/8 in. across are acceptable unless numerous. Repair larger bare spots in accordance with Section 445.3.D, "Repairs." Runs or drips of zinc coating are

445.3 to 445.3

acceptable unless they interfere with the intended use of the product. Carefully hand-file excessive zinc accumulations.

2. **Adhesion.** To test coating adhesion, tap the coated area with a small hammer. The coating is acceptable if it is not brittle and does not scale or flake.
 3. **Appearance.**
 - a. **White Rust.** A white powdery residue indicates moisture. Remove heavy layers of white rust that have caused the coating to pit. Light coatings may remain unless the Engineer requires chemical removal. Remove white rust from articles that will be in direct contact with soil.
 - b. **Red Rust.** Red rust on galvanized items indicates uncoated areas. See Section 445.3.C.1, "Coverage," for acceptance criteria.
 - c. **Alligator Cracking or Spider Webbing.** The composition of the base metal may cause dark lines resembling alligator skin. See Section 445.3.C.2, "Adhesion," to determine whether the coating is acceptable.
 - d. **Dull Gray Coating.** The composition of the base metal can cause a dull gray color. See Section 445.3.C.2, "Adhesion," to determine whether the coating is acceptable.
 4. **Coating Thickness.** Galvanize to the thickness specified. Use Tex-728-I to determine coating thickness.
- D. Repairs.** Use zinc-based solders, sprayed zinc, or zinc-rich paints for repairs, in accordance with this Section.
1. **Materials.**
 - a. **Zinc-Based Solders.** Solders used in rod form or as powders:
 - zinc-tin-lead alloys with liquidus temperatures in the range of 446°F to 500°F or
 - zinc-cadmium alloys with liquidus temperatures in the range of 518°F to 527°F.
 - b. **Sprayed Zinc (Metallizing).** Zinc coating applied by spraying with droplets of molten metal using wire, ribbon, or powder processes.
 - c. **Organic Zinc-Rich Paints.** Zinc-rich paints based on organic binders that:
 - are premixed and formulated specifically for use on steel surfaces and

- will provide a dried film containing a minimum of 94% zinc dust, by weight.

2. Repair Processes.

- a. Zinc-Based Solders.** Remove moisture, oil, grease, dirt, corrosion products, and welding slag or flux from surfaces to be repaired. Clean surface to white metal by wire brushing, light grinding, or mild blasting extending into the surrounding undamaged galvanized coating. Preheat cleaned areas to at least 600°F but not more than 750°F. Wire-brush while heating and evenly distribute a layer of zinc solder. When repair is completed, flush the repaired area with water or wipe with a damp cloth to remove flux residue.
 - b. Sprayed Zinc (Metallizing).** Remove oil, grease, corrosion products, and any welding slag or flux from surfaces to be repaired, and ensure that the surfaces are dry. Clean surface to white metal by wire brushing, light grinding, or mild blasting extending into the surrounding undamaged galvanized coating. Apply coating by metal-spraying pistols fed with either zinc wire or zinc powder. Provide a coating that is uniform and free of lumps, coarse areas, or loose particles.
 - c. Organic Zinc-Rich Paints.** Do not use paint to repair galvanizing damage caused by welding. Remove oil, grease, corrosion products, and welding slag or flux from surfaces to be repaired, and ensure that the surfaces are clean and dry. Clean surface to near-white metal by wire brushing, light grinding, or mild blasting extending into the surrounding undamaged coating to provide a smooth repair. Spray or brush-apply the paint to the prepared area in accordance with the paint manufacturer's instructions to attain the required dry-film thickness. Provide multiple passes when using spray application.
- 3. Repair Coating Thickness.** After completing repair and cooling or curing, measure thickness in the repaired area using Tex-728-1. The minimum thickness required is the same as that required for the specified galvanizing. However, if the repair uses zinc-rich paints, the minimum coating thickness is 50% higher than the specified galvanizing thickness, but not greater than 4.0 mils.

445.4 to 446.2

445.4. Measurement and Payment. The work performed, materials furnished, equipment, labor, tools, and incidentals will not be measured or paid for directly but will be considered subsidiary to pertinent Items.

ITEM 446 CLEANING AND PAINTING STEEL

446.1. Description. Prepare steel surfaces for painting and apply paint.

446.2. Materials. Provide the paint system (surface preparation, primer, intermediate, and appearance coats as required) shown on the plans. Provide System II with #742 Gray Appearance Coat if no system is specified. Provide a concrete gray appearance coat (Federal Standard 595B color 35630) if appearance coat is required unless otherwise shown on the plans.

If faying surfaces will be painted, provide a prime coat that is documented to have the required slip and creep characteristics (as determined by “Testing Method to Determine the Slip Coefficient for Coatings Used in Bolted Joints” in the Research Council on Structural Connections’ Specification for Structural Joints Using ASTM A325 or A490 Bolts) to meet the required mean slip coefficient shown on the plans. Perform all required testing at no expense to the Department.

- A. Paint Systems.** Standard paint systems for painting new and existing steel include the following.
- 1. System I (Overcoating).** Provide paint in accordance with DMS-8101, “Structural Steel Paints-Performance.” Provide a penetrating sealer, intermediate prime coat on bare steel areas, and an appearance coat in accordance with manufacturer’s specifications. This system is used for repainting existing steel and used only when specified on the plans.
 - 2. System II.** Provide #810 Prime Coat meeting DMS-8100, “Structural Steel Paints-Formula.” For appearance coat, provide either #742 Gray Appearance Coat meeting DMS-8100 or acrylic latex meeting DMS-8101, “Structural Steel Paints-Performance,” as specified. This system is used for painting new steel and repainting existing steel.
 - 3. System III.** Provide paint in accordance with DMS-8101, “Structural Steel Paints-Performance.” Provide inorganic zinc (IOZ) prime coat, epoxy intermediate coat, and urethane

appearance coat for all outer surfaces except those to be in contact with concrete. Provide epoxy zinc prime coat for areas to be in contact with concrete and for touchup of IOZ. This system is used for painting new steel.

4. **System IV.** Provide paint in accordance with DMS-8101, “Structural Steel Paints-Performance.” Provide IOZ prime coat and acrylic latex appearance coat for all outer surfaces except those to be in contact with concrete. Provide epoxy zinc prime coat for areas to be in contact with concrete and for touchup of IOZ. This system is used for painting new steel.
- B. Paint Inside Tub Girders and Closed Boxes.** Provide a white polyamide cured epoxy.
- C. Paint over Galvanizing.** Provide epoxy intermediate coat and urethane appearance coat in accordance with DMS-8101, “Structural Steel Paints-Performance.” Provide intermediate coating recommended by the manufacturer for use on galvanized steel.
- D. Special Protection System.** Provide the type of paint shown on the plans or in special provisions to this Item.

446.3. Equipment. Ensure that spray equipment:

- has adequate capacity and sufficient gauges, filters, agitators, regulators, and moisture separators to ensure delivery of clean dry air at the proper pressure and volume;
- is adequate for the type of paint being used;
- has spray heads that provide a smooth, uniform coat of paint;
- can separate moisture from air stream in contact with the paint; and
- has no dried coatings, solvents, or other foreign matter on surfaces that paint is likely to contact.

Maintain all equipment and accessories in good working order.

During painting operations, keep paint pots no more than 20 ft. above or below the level of spray application of paint. Do not allow fluid hoses to sag more than 10 ft. below the level of the bottom of the paint pot or actual spraying operations, whichever is the lowest point. Keep hoses serviceable with no cracks or deterioration. Equip paint pots (or other containers from which the paint is dispensed) with agitators that operate whenever paint is in the pot.

- A. Airless Spray Equipment.** Use regulator and air or fluid pressure gauges. Use fluid hoses with at least 1/4 in. I.D. and a maximum length of 75 ft.

446.4 to 446.4

- B. Conventional Spray Equipment.** Use independent fluid pressure and atomization pressure regulators and gauges. Use fluid and air hoses with at least 1/2 in. I.D. and a maximum length of 75 ft.

446.4. Construction.

- A. Qualification.** Certification of the cleaning and painting contractor, subcontractor, or fabricator is required as follows.
- 1. Shop Cleaning and Painting.** Follow all applicable provisions for qualification specified in the AASHTO/NSBA Steel Bridge Collaboration S8.1.
 - 2. Field Cleaning and Painting.** Maintain SSPC-QP 1 (for paint application and removal of coatings not containing hazardous materials) and SSPC-QP 2 (for removal of coatings containing hazardous materials) certification for the duration of the project when the following conditions exist:
 - total steel surface area to be cleaned and painted exceeds 15,000 sq. ft.,
 - existing coating to be removed from steel contains hazardous materials as specified on the plans, or
 - certification is required on the plans.Submit proof of certification before beginning work.
- B. Responsibility for Hazards.** Some paints and cleaning products are harmful to health. Handle all paints and cleaning products in accordance with the information on the manufacturer's safety data sheet and in accordance with all applicable federal and state regulations. Comply with all worker and public safety protection measures including 29 CFR 1926.62 when cleaning requires removing paint containing lead or chromium. Monitor permissible exposure limits (PEL) in accordance with OSHA requirements.
- C. Access.** Provide safe access to all parts of the work for proper inspection. Do not place rigging, scaffolds, etc., in contact with previously painted surfaces until the previously applied coating has had at least 48 hours of curing time. Protect previously painted and cured surfaces with an approved padding to minimize damage when rigging, scaffolds, etc., will be placed on or hung from those surfaces. Repair all coating damaged as a result of rigging or scaffolding as directed.
- Remove tree limbs, bushes, grass, and other items that will interfere with the cleaning and painting operations as directed. Remove vertical clearance signs, and erect and maintain temporary ground-mounted

signs matching the content and letter size on the existing sign unless otherwise directed. Re-attach permanent clearance signs as directed.

- D. Steel to be Painted.** Clean and paint all structural steel except weathering steel that is to remain unpainted, unless otherwise shown on the plans. Structural steel includes all main members, bearing apparatus, diaphragms, and lateral bracing where applicable. Unless otherwise shown on the plans or exempted in this Item, paint the rolling faces of rockers and base plates, all surfaces of bearing plates, and all surfaces of iron or steel castings, whether or not the surfaces are milled. Unless otherwise provided in the Contract or approved in writing, perform the initial cleaning and application of required prime and intermediate coatings on new steel before shipment of the steel to the job site.
- E. Painting Galvanized Surfaces.** Do not water-quench or chromate-quench galvanized surfaces to be painted. Wash the surface to be painted with a biodegradable alkaline detergent to remove oil, grease, flux, white rust, dirt, and any other contaminants. Thoroughly rinse the surface with potable water to remove remaining detergent. Remove remaining oily contamination with a clean solvent. Properly label and store then recycle or dispose of spent solvents.

Lightly abrasive-blast the surface to be painted, or use another approved method to show an etched pattern on the entire surface without removing any of the zinc. Apply primer within 24 hours of cleaning. Reclean the surface if more than 24 hours elapse before painting.

Apply at least 2.0 mils dry film thickness (DFT) of intermediate coating and at least 2.0 mils DFT of appearance coating.

Ensure that the appearance coating dries to form a smooth, continuous, tightly adhering film of uniform thickness and appearance, free of sags, runs, pinholes, holidays, overspray, and any other discontinuities; and that it has a uniform appearance within all portions of the painted piece and all related pieces and components of a job.

- F. Shop Cleaning and Painting.** Unless otherwise approved, do not apply coatings until all fabrication work is completed and has been tentatively accepted.

Follow all applicable provisions of AASHTO/NSBA Steel Bridge Collaboration S8.1, for both organic and inorganic zinc-based primer systems, except as modified by this Item. Use the paint systems specified in this Item and on the plans and meet the dry film thickness

(DFT) requirements of this Item instead of those of S8.1. The requirement to test for primer curing using ASTM D 4752 does not apply to organic zinc primer. Use Tex-728-I instead of SSPC-PA2 for measuring DFT.

Repair all runs, sags, and other defects in each coat before application of subsequent coats.

Clean and paint surfaces that will be in contact with concrete, such as the top surfaces of top flanges, in accordance with the specified system except as modified in this Section or otherwise shown on the plans.

Designate no-paint areas on the shop drawings.

Paint erection marks for field identification of members upon previously painted surfaces. Do not load pieces for shipment until coatings are thoroughly dry. Except for small approved touchups, do not apply any paint after material is loaded for shipment.

1. Faying Surfaces.

- a. **Painted.** When painting faying surfaces, ensure that the primer used is documented to have the required slip and creep characteristics. If no mean slip coefficient (or corresponding surface condition) is specified, do not paint faying surfaces without approval.

Apply no more than the maximum average film thickness used in the qualifying test to the faying surfaces. Before bolting, ensure that paint on faying surfaces has cured for the minimum time used in the qualifying test. Perform all required testing of the paint at no additional expense to the Department.

- b. **Unpainted.** If surfaces to be in contact after final bolting will be left unpainted, provide an SSPC-SP 10 blast-cleaning, and ensure that these areas are free of paint and overspray to within 1 in. or 1 bolt diameter, whichever is less, from the outside edges of the bolt holes. Do not power wire-brush uncoated faying surfaces. Roughen galvanized faying surfaces by hand wire-brushing. Remove tape from masked areas as soon as practical.

For unpainted top lateral bracing connections shown on the plans as designed to AASHTO Class A surface condition (slip coefficient of 0.33), an SSPC-SP 10 blast-cleaning is not required. Remove grease and loose mill scale from nonweathering steel, and remove grease and all mill scale from weathering steel. If no slip coefficient or assumed

surface condition is shown on the plans or if the connection is shown as Class B (slip coefficient 0.50), provide an SSPC-SP 10 blast.

2. **No-Paint Areas at Field-Welded Connections.** Do not paint surfaces within 4 in. of groove welds or within 2 in. of fillet welds. Do not apply intermediate coat within 4 in. of the edge of primer at these areas. Remove tape from masked areas as soon as practical after painting.
3. **Paint Application for Specified Systems.**
 - a. **System II.**
 - (1) **Prime Coat.** Apply a total of 3.5 to 10.0 mils DFT of primer in at least 2 coats to outer surfaces that will not be in contact with concrete. Extend the primer at least 1-1/2 in. onto surfaces that will be in contact with concrete, such as top flanges (see Figure 1). Coat the remaining portion of the surfaces to be in contact with concrete with a film coat of tightly adhering primer.
 - (2) **Appearance Coat.** If the appearance coat is shop-applied, apply at least 2.0 mils DFT of appearance coating to outer surfaces that will not be in contact with concrete. Do not extend the appearance coat onto surfaces that will be in contact with concrete.

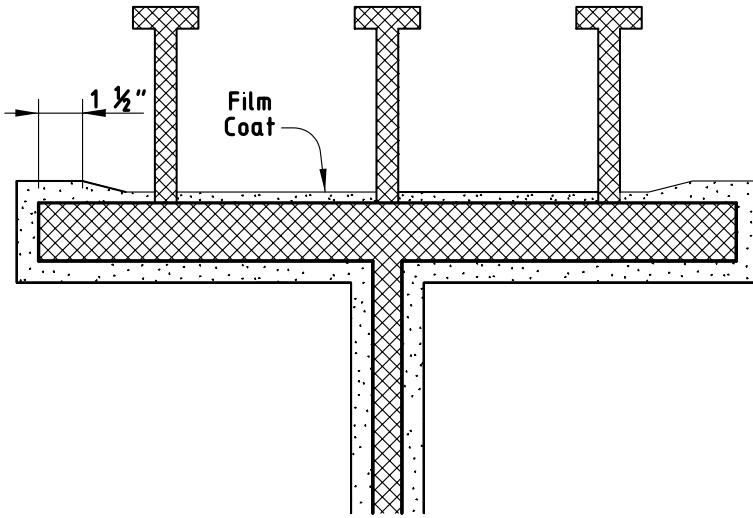

 System II Primer

 Steel Girder and Shear Stud

Figure 1

Application areas of System II paint (appearance coat not shown).

b. System III.

- (1) **Outer Surfaces Not in Contact with Concrete.** Extend prime and intermediate coatings at least 1-1/2 in. onto surfaces that will be in contact with concrete, such as top flanges (see Figure 2).

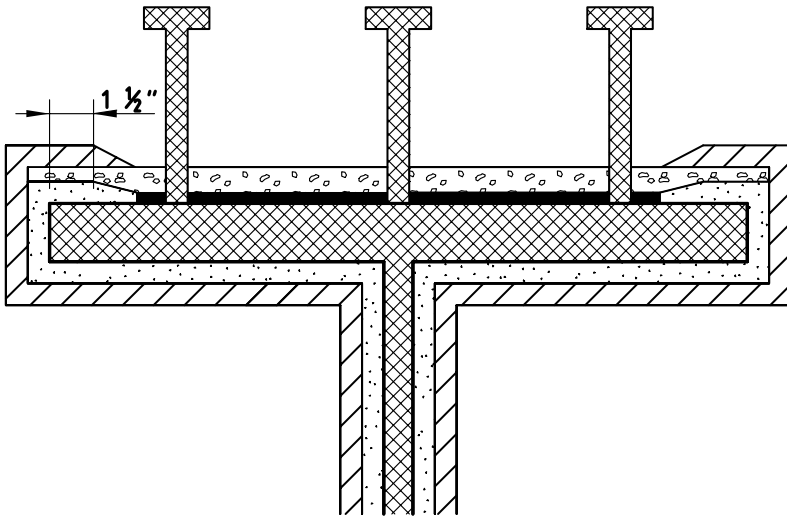





-  System III IOZ Primer Film Coat (Optional)
-  System III IOZ Primer
-  System III Epoxy Zinc Primer
-  System III Epoxy Intermediate
-  Steel Girder and Shear Stud

Figure 2

Application areas of System III paints (appearance coat not shown).

- (a) **Prime Coat.** Apply at least 3.0 mils DFT of IOZ primer. Surfaces to be in contact with concrete may be covered with a film coat of IOZ primer. Thoroughly wet coated surfaces with a fine mist of potable water after the primer has set. Test the IOZ primer for cure in accordance with ASTM D4752. If the IOZ primer meets a resistance rating of 4 or higher, apply the intermediate coat. If it does not meet this rating, reapply a fine mist of potable water

until the coating is cured. Alternative cure tests may be used if recommended by the coating manufacturer.

(b) Intermediate Coat. Apply at least 2.0 mils DFT of epoxy intermediate coating after primer (including epoxy zinc on top flange; see 446.4.F.3.b(2), “Surfaces to be in Contact with Concrete”) has met curing requirements.

(c) Appearance Coat. If appearance coat is shop-applied, apply at least 2.0 mils DFT of appearance coating.

(2) Surfaces to be in Contact with Concrete. See Figure 2. Before coating surfaces to be in contact with concrete, ensure that the IOZ prime coat has met curing requirements. Allow the surface to dry before evaluating the condition of the IOZ primer. If the surface to be in contact with concrete shows metal oxidation or if IOZ primer present on that surface is mud-cracked, reclean the surface to specified requirements. Do not damage the IOZ primer on other surfaces during recleaning. Paint on shear studs is not required. Apply 2 coats of 3 to 5 mils wet film thickness (WFT) each of epoxy zinc primer to a clean, dry surface. Wait between 1 and 48 hours between coat applications.

c. System IV.

(1) Outer Surfaces Not in Contact With Concrete.

(a) Prime Coat. Apply at least 3.0 mils DFT of IOZ primer. Extend primer at least 1-1/2 in. onto surfaces that will be in contact with concrete, such as top flanges (see Figure 3). Thoroughly wet all coated surfaces with a fine mist of potable water.

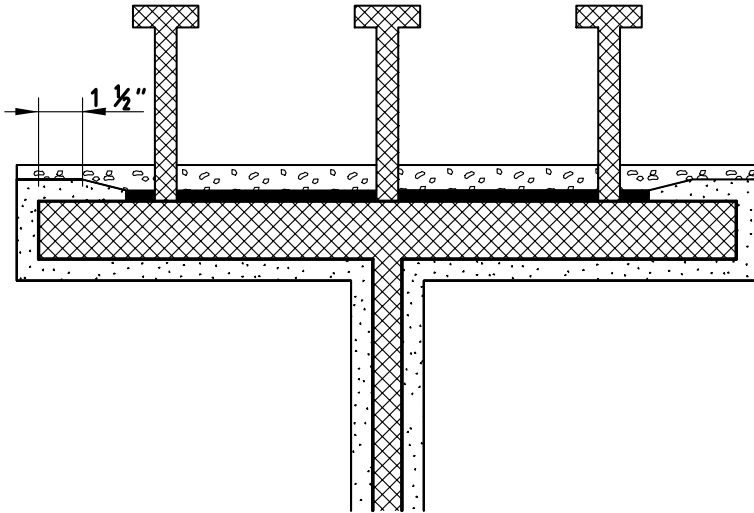

- System IV IOZ Primer Film Coat (Optional)
- ◻ System IV IOZ Primer
- ◻ System IV Epoxy Zinc Primer
- ◻ Steel Girder and Shear Stud

Figure 3
Application areas of System IV paints (appearance coat not shown).

- (b) **Appearance Coat.** If appearance coat is shop-applied, test the IOZ primer for cure in accordance with ASTM D 4752. If the IOZ primer meets a resistance rating of 4 or higher, apply the appearance coat. If it does not meet this rating, reapply potable water with a fine mist until the coating is cured. Alternative cure tests may be used if recommended by the coating manufacturer. Apply at least 2.0 mils DFT of appearance coating.
- (2) **Surfaces to be in Contact with Concrete.** Coat surfaces to be in contact with concrete in accordance with

Section 446.4.F.3.b(2), "Surfaces to be in Contact with Concrete."

- d. **Paint Inside Tub Girders and Closed Boxes.** Provide an SSPC-SP 7 blast-cleaning to unpainted surfaces. Apply 2 to 3 mils DFT of paint over all inside surfaces that will be visible after final bolting including exposed surfaces of interior splice plates.
 - e. **Special Protection System.** Apply paint as shown on the plans.
4. **Repairs.** If repairs must be made after the IOZ primer has cured, use epoxy zinc primer to repair the IOZ primer. Brush application for touchup is acceptable as long as the paint is mixed in the appropriate proportions by weight and is agitated continuously during the painting operation.
- G. **Field Cleaning and Painting.** Clean and paint only after erection or maintenance work including bolting, welding, straightening of material, etc. is complete; slab concrete has been placed; and the Engineer has examined and approved the work. Clean and paint unpainted areas including bolts, nuts, washers, and areas where the shop-applied paint has been damaged or fails to meet specification requirements, in accordance with the method required under the paint system specified. Prevent paint spatter and overspray from coming in contact with passing traffic, private and public property, and areas of the bridge not designated to be painted.

1. **Containment.** Submit a plan that details the procedures and type and size of equipment proposed to keep public property, private property, and the environment from being adversely affected by the cleaning and painting operations. Approval of the plan is required before cleaning and painting operations begin.

When required on the plans, submit an analysis showing the loads, including wind loads, added to the existing structure by the containment system and waste materials. Verify that the forces and stresses induced in the members from these loads do not cause them to be overstressed. Have a licensed professional engineer sign, seal, and date the submittal.

When abrasive-blasting is used to remove the existing coating, provide a containment system capable of containing all blast refuse. Unless otherwise shown on the plans, construct and maintain a structure meeting the following minimum requirements:

- rigid or flexible framing;
- ability to withstand winds up to 30 MPH;
- enclosure of all sides of area with air-penetrable or air-impenetrable walls;
- watertight floor;
- overlapping seams and entryways; and
- exhaust air filtration system capable of creating negative pressure inside the enclosure causing the sides of the containment to have a concave appearance.

In place of a full containment structure, a modified containment system may be proposed when using abrasive-blasting equipment equipped with negative pressure that will contain all blast refuse. Demonstrate for approval the equipment's ability to contain all blast refuse.

When using hand tools, provide a system that will contain all removed paint, rust, and other debris. Place an airtight membrane below the member being cleaned to collect all falling debris. When using power hand tools, equip them with high-efficiency particulate air (HEPA) filter vacuums or provide a full containment system as specified above.

When using water-blasting (low-pressure or high-pressure), provide a system capable of collecting all falling paint chips and other debris. Store, characterize, and dispose of all recovered debris in accordance with 30 TAC 335, "Industrial Solid Waste and Municipal Hazardous Waste." Discharge liquids in accordance with the TCEQ Texas Pollution Discharge Elimination Program (30 TAC 305, "Effluent Guidelines and Standards for TPDES Permits") and Texas Surface Water Quality Standards (30 TAC 307). Alternatively, liquids may be captured, stored and characterized for disposal at an authorized facility in accordance with 30 TAC 315, "Pretreatment Regulation for Existing and New Sources of Pollution," or 30 TAC 335, "Industrial Solid Waste and Municipal Hazardous Waste."

Remove all blast refuse from the floor and cleaned members before the Inspector enters the containment to inspect the cleaned surfaces. Remove all blast refuse from the containment before ending work for the day.

Provide containment during the priming operation to provide a wind-free environment and to keep the primer from entering the

environment. Obtain approval of the containment system prior to beginning work.

Use a skimmer when cleaning and painting over bodies of water. If the skimmer collects any blast or paint material, remove the material the day the release occurs. Correct the containment problem that allowed the release before continuing work.

2. Cleaning and Preparation of Surfaces. Prepare surfaces prior to applying paint.

a. General Preparation. Clean far enough into the shop-applied paint to ensure removal of all contaminants. Feather edges of sound paint around cleaned areas.

Ensure that surfaces to be painted are completely free of oil, grease, moisture, dirt, sand, overspray, welding contamination (slag or acid residue); loose or flaking mill scale, rust, or paint; weld spatter; and any other conditions that will prevent the paint from forming a continuous, uniform, tightly adhering film. Remove all steel splinters (hackles) raised or evident during cleaning. When abrasive blast-cleaning is required, reblast areas from which hackles are removed. Use the test described in Section 446.4.G.2.c, "Tape Test," on all surfaces to be painted to determine if they are contaminated with loose particles.

Before other cleaning operations, remove grease-like contaminants with clean petroleum solvents or other approved methods. Contain solvents and removed material as approved. Dispose of properly or reuse solvents as approved. This requirement applies to all coats.

When abrasive blast-cleaning is required, blast all flame-cut edges to produce a visible anchor pattern over the entire flame-cut surface.

Completely remove, as directed, the protective coating on machined surfaces and pins.

b. Classes of Cleaning. The requirements of Section 446.4.G.2.a, "General Preparation," apply whether or not a class of cleaning is specified. For blasting, use an approved abrasive as shown on the plans and potable water. Do not use steel shot. When abrasive blast-cleaning is used to remove existing paint containing lead or chromium, use an abrasive recycling system with an approved recyclable

abrasive. Abrasive will be considered recyclable if it is separated from the dust and paint debris before being reused.

- (1) **Class A Blast-Cleaning.** Remove all visible rust, paint, mill scale, and other forms of contamination, so that the blasted surface appears near white when viewed with the unaided eye (corrected to 20/20 vision). Slight staining is allowed provided it does not exceed 5% in any 9-sq. in. area. Staining includes light shadows, slight streaks, or minor discoloration caused by stains from rust, mill scale, or previously applied paint. Meet the surface preparation requirements of SSPC-SP 10 unless otherwise shown on the plans.
- (2) **Class B Blast-Cleaning.** Remove all dirt, rust scale, loose mill scale, loose rust, and loose paint. Tight mill scale and tightly adhered rust and paint are permitted. Expose each square inch of surface area to be cleaned to the abrasive-blast pattern long enough to expose several flecks of the underlying metal. Meet the surface preparation requirements of SSPC-SP 7. Use the test described in Section 446.4.G.2.c, "Tape Test," on the cleaned surface to determine if it is adequately cleaned.
- (3) **Class C Cleaning.** Remove all exposed loose rust, loose mill scale, peeling or flaking paint, and oxidized paint. Clean these areas by hand-scraping, wire-brushing, or other approved method. Feather all sound, tightly adhered coating edges surrounding cleaned areas.
- (4) **Class D Water-Blasting.** Remove all dirt, loose rust, and loose paint using water-blasting equipment. Tight mill scale and tightly adhered rust and paint are permitted. Probe perimeter of peeled areas of paint with a putty knife to ensure remaining paint is tightly adhered.

System I requires Class D water-blasting to remove contaminants, followed by a Class C cleaning for defective areas. If prime coat is field-applied, System II requires Class A blast-cleaning. If prime coat is shop-applied, Systems II, III, and IV require Class A spot-cleaning of all damaged and unpainted areas.

- c. **Tape Test.** Perform the tape test as follows:
 - Press a strip of filament tape onto the surface by rubbing with moderate thumb pressure 4 times, leaving

approximately 2 in. of one end of the tape free from the surface.

- Grasp the free end and remove the tape from the surface with a sharp pull.

The surface will be considered to be contaminated and not adequately cleaned if visible particles cling to the tape.

3. Painting.

- Paint Condition.** Thoroughly mix and strain paints to be applied. Mix by mechanical methods. Ensure that the paint is a completely homogeneous mixture free of lumps, skins, and agglomerates and that it contains all pigments, vehicle solids, and thinners required in the original formulation. Keep paint containers tightly covered and protected from weather when not in use.
- Thinning.** Adjust paint to the correct application consistency by using suitable thinners or by using properly applied heat up to 150°F. Using heat to thin epoxy paints may decrease their useful pot life.
- Paint System Requirements.** Ensure that all coatings in the paint system, including shop-applied coats, are from the same manufacturer.

(1) System I (Overcoating).

- Penetrating Sealer.** Apply at least 1.0 mil DFT of penetrating sealer to all surfaces to be painted.
- Prime Coat.** Apply at least 4.0 mils DFT of primer to areas that have received a Class C cleaning and to other areas where there is no existing primer.
- Appearance Coat.** Apply at least 2.0 mils DFT of appearance coat.

(2) System II.

- Prime Coat.** Apply 3.5 to 10.0 mils DFT of primer in at least 2 coats.
- Appearance Coat.** Apply at least 2.0 mils DFT of appearance coat.

(3) Systems III.

- (a) Prime Coat.** Spot-clean to Class A all damaged and unpainted areas. Apply at least 3.0 mils DFT of epoxy zinc primer to the cleaned areas.
- (b) Intermediate Coat.** If intermediate coat is not shop-applied, apply at least 2.0 mils DFT of epoxy intermediate coating.
- (c) Appearance Coat.** Apply at least 2.0 mils DFT of appearance coat.

(4) System IV.

- (a) Prime Coat.** Spot-clean to Class A all damaged and unpainted areas. Apply at least 3.0 mils DFT of epoxy zinc primer to the cleaned areas.
- (b) Appearance Coat.** Apply at least 2.0 mils DFT of appearance coat.

(5) Special Protection System. Apply paint as shown on the plans.

- d. Temperature.** Do not apply #810 Prime Coat when the steel or air temperature is below 50°F or when the steel or air temperature is expected to drop below 50°F within 2 hr. after application. Do not apply #742 Appearance Coat when the steel or air temperature is below 40°F or when the steel or air temperature is expected to drop below 40°F within 2 hours after application. Follow product data sheets for temperature requirements for all other paints.
- e. Application.** Immediately before painting, clean steel surfaces or surfaces of previously applied coats of paint by blowing with clean compressed air, brushing, or both to remove traces of dust or other foreign particles. When directed, wash the surfaces of previously applied coatings either with clean, fresh water or with a mild detergent and water mixture followed by a complete and thorough rinse with clean, fresh water.

Do not apply paint to any surface with discernible moisture. Do not apply paint to any surface when the relative humidity is greater than 85% as determined by a sling psychrometer in accordance with ASTM E 337. Do not apply any paint when impending weather conditions might result in injury to fresh paint.

Do not apply paint to any surface when the relative humidity is greater than 85% as determined by a sling psychrometer in accordance with ASTM E 337.

Apply each coat of paint to clean, dry, firm surfaces complying with all specification requirements. Ensure that surfaces to be painted are free of all forms of contamination. Ensure that each coat dries to form a smooth, continuous, tightly adhering film of uniform thickness and appearance, free of sags, runs, pinholes, holidays, overspray, or other defects. Apply all coats by spray, except that any approved method of application may be used to paint inaccessible areas.

Repair all runs, sags, and other defects in each coat of paint before application of subsequent coats.

Measure the dry film thickness of coatings in accordance with Tex-728-I.

If, in the opinion of the Engineer, there is an objectionable amount of dust in the atmosphere, discontinue painting or take necessary precautions to prevent dust and dirt from coming in contact with freshly painted surfaces or with surfaces before the paint is applied.

Where there is potential for paint to be sprayed on traffic, provide a shield that will protect the traffic from paint.

When painting steel that is in contact with concrete, provide full coverage of the steel with a minimal amount of paint on the concrete surface. Do not extend the paint more than 4 in. onto the concrete surfaces or as directed. Ensure that when painting is complete, the only visible paint on concrete surface is the finish coat. Remove excessive or objectionable paint on concrete surfaces in an approved manner.

(1) Prime Coat. Paint cleaned areas with the specified prime coat. Overlap painting onto the surface of the shop-applied paint enough to form a sealed edge.

When System III or IV is specified, paint spot-repair and unpainted areas with epoxy zinc primer. Cure the epoxy zinc primer in accordance with the manufacturer's product data sheet before applying appearance coat.

When System II is specified and the steel and the ambient temperature are both above 60°F, the second coat of primer may be applied before the first coat has cured but

not within 2 hours after the application of the first coat. Cure the primer in accordance with Table 1 before applying appearance coat.

Table 1
System II Primer Cure Times

Temperature	Days Cure, Min.
77°F and above	2
65 to 77°F	3
55 to 65°F	4
40 to 55°F	5

- (2) **Appearance Coat.** After field-painting of the prime coat in accordance with Section 446.4.G.3.e(1), “Prime Coat,” is completed and approved, apply the specified appearance coat.

Clean prime coat and intermediate coat surfaces by an approved method which does not damage the paint to remove all dirt, grease, concrete, overspray, and any other substance that may impair adhesion before the application of the appearance coat.

Provide an even and uniform appearance throughout the painted portion of the structure.

- f. **Workmanship.** Perform all painting with skilled painters who can adjust equipment and application techniques as dictated by the type of paint, weather conditions, environment, and size and shape of the surface being painted. Painters who, in the opinion of the Engineer, do not adjust equipment to apply coatings in a uniform full wet coat free of runs, sags, holidays, and overspray will not be considered skilled painters.

Apply sprayed coatings essentially 90° to the surface and between 10 and 18 in. from the surface as necessary to apply a full wet coat of paint free of overspray, runs, sags, and holidays. Any spray painter who does not consistently spray in this manner or extends the spraying stroke so that paint is applied to the surface at an angle of less than 80° will not be allowed to spray paint. Brush application for touchup is acceptable as long as the paint is mixed in the appropriate proportions by weight and is agitated continuously during the painting operation.

446.4 to 446.4

4. **Handling and Shipping.** Pad the blocks, chains, slings, braces, clamps, etc., used for handling, moving, storing, and shipping painted members so that the paint will not be damaged.
5. **Cleaning and Painting Existing Structures.** Unless otherwise shown on the plans, provide System II for existing steel structures to be cleaned and painted.

H. Paint Improperly Applied. To uncover evidence of improperly applied paint, the Engineer may at any time during construction explore underneath the surface of any paint coats already applied. Repair these areas of investigation at no additional expense to the Department. Whenever unsatisfactory conditions are found, the Engineer may require remedial measures.

Repair or completely remove and replace all paint that has been applied improperly, has been applied to improperly cleaned surfaces, fails to dry and harden properly, fails to adhere tightly to underlying metal or other paint film, or does not have a normal, workmanlike appearance in conformance with this Item. When the final field coat does not have a uniform color and appearance throughout the structure, correct it by the use of whatever additional coats or other corrective measures are required. Remove freshly applied paint that has not yet set with the use of suitable solvents. Remove dried paint films with blast-cleaning, scraping, or flame torches, as approved.

I. Storage and Disposal. Collect all waste generated by cleaning and painting operations as necessary to prevent release into the environment. At a minimum, collect all waste before leaving the job site each day. Handle and store the waste as if it were hazardous until classification is made. Follow the requirements of 30 TAC 335 for on-site handling of the waste. Store waste collected in containers that comply with 49 CFR 178. Seal containers containing waste each day before leaving the job site.

Test each container of waste using EPA Test Method 1311, "Toxicity Characteristic Leaching Procedure" (TCLP), to determine existing metal and organic content. If testing shows that the waste is not hazardous, handle and dispose of the waste as a "Special Waste" as defined in 30 TAC 330.2 or as directed. Provide documentation showing that disposal of the waste was done in a suitable landfill holding permits to handle this type of material. If testing shows that the waste is hazardous, dispose of the waste in compliance with applicable hazardous waste rules and regulations. Transport hazardous waste using

a permitted transporter and dispose of in an authorized hazardous waste facility.

When the plans specify that the existing coating to be removed contains hazardous materials and steel grit is used as the abrasive, the waste generated is classified as hazardous regardless of the results of the TCLP. Dispose of this waste in compliance with applicable hazardous waste rules and regulations as specified above and by the Contract.

Provide copies of all test reports and transportation manifests to the Engineer before shipping hazardous waste. Provide signed original manifests to the Engineer verifying that all steps of the handling and disposal process were correctly handled.

- J. Miscellaneous.** Notify the Engineer of any condition that may require the repair or replacement of any portion of the bridge.

Upon completion of the painting operations for each structure, stencil on the exterior face of the outside beam the control, section, and structure number, as directed. Stencil on the interior face of the outside beam the completion date of the painting operation. Do this work at each end of the structure where painting is specified.

446.5. Measurement. When this Item is specified on the plans to be a pay item, it will be measured by the lump sum or by each structure, structure unit, or group of structures as shown on the plans.

446.6. Payment. The work performed, materials furnished, equipment, labor, tools, and incidentals will not be measured or paid for directly, but will be subsidiary to bid items of the Contract, unless otherwise specified as a pay item in the Contract.

When this Item is specified as a pay item, the work performed and materials furnished in accordance with this Item and measured as provided under “Measurement” will be paid for at the price bid for “Cleaning and Painting Existing Structures,” “Cleaning and Painting Existing Railing,” or “Cleaning and Painting Existing Piling” for the system specified and, when paid by each, for the structure description by reference number. “Cleaning and Painting Existing Structures” includes painting of railing and piling unless otherwise shown on the plans. This price is full compensation for paint; cleaning, spot painting, and painting; removal of vegetative obstructions; containment systems; traffic protection and scaffolding; disposal of waste; and materials, equipment, labor, tools, and incidentals.

ITEM 447
STRUCTURAL BOLTING

447.1. Description. Furnish and install high-strength bolts for structural connections.

447.2. Materials.

- A. General.** Use the same supplier for bolts and nuts to ensure proper fit. Have the manufacturer or distributor perform rotational-capacity (R-C) tests in accordance with Tex-452-A on all black or galvanized bolt, nut, and washer assemblies. Test each combination of bolt production lot, nut lot, and washer lot as an assembly and assign an R-C lot number to each lot tested. Test 2 samples from each assigned R-C lot.

Furnish a manufacturer's certified test report (MCTR) or a distributor's certified test report (DCTR) for each R-C lot supplied. Include in the MCTR or DCTR:

- results of the R-C tests,
- R-C lot number,
- manufacturing location for assembly components,
- date and location of tests, and
- a statement that the materials represented by the test report conform to the specifications.

- B. Bolts.** Use bolts that meet the requirements of ASTM A 325 or A 490 except as modified in this Item. Provide bolts long enough for the installed bolt end to be flush with or outside the face of the nut.

For weathering steel, use Type 3 bolts that meet ASTM A 325 or A 490. Use ASTM A 325 Type 1 for galvanized bolts.

Provide bolts with UNC series threads for diameters less than or equal to 1 in. Provide bolts with 8UN series threads for diameters greater than 1 in.

- C. Nuts.** Use nuts that meet the requirements of the applicable ASTM bolt specification (ASTM A 325 or A 490) and the applicable ASTM nut specification (ASTM A 563 or A 194) except that grade 2, C3, D, and D3 nuts must have a minimum Rockwell B hardness of 89.

Provide nuts with UNC series threads for diameters less than or equal to 1 in. Provide nuts with 8UN series threads for diameters greater than 1 in.

Ensure that galvanized nuts are lubricated with a lubricant containing a dye of a color that contrasts with the color of the galvanizing. If

ASTM A 563 nuts will be galvanized, order them with supplemental requirement S2.

- D. Washers.** Use washers that meet the requirements of ASTM F 436 and the applicable ASTM bolt specification (ASTM A 325 or A 490).
- E. Storage.** Protect all bolts and nuts from dirt and moisture at the job site. Remove from protected storage only those bolts and nuts anticipated to be installed during a workday. Return unused fasteners to protected storage at the end of the day. Do not clean fasteners of lubricant present in the as-delivered condition. As directed, perform at the Contractor's expense a field R-C test in accordance with Tex-452-A on any lot of fasteners that shows signs of rust, dirt, or loss of lubrication. If the fasteners fail the R-C test, apply additional lubrication and rerun the R-C test before installing bolts. Replace any fasteners that cannot be re-lubricated to pass the field R-C test.
- F. Sampling and Testing.** High-strength bolts, nuts, and washers may be sampled in accordance with Tex-719-I. Perform field R-C tests as directed in accordance with Tex-452-A. Perform installation verification tests required in Section 447.4.A, "Equipment Preparation."
- G. Fitup Bolts and Erection Pins.** Provide fitup bolts of the same diameter as the connection bolts. Do not reuse galvanized bolts or ASTM A 490 bolts that have been used as fitup bolts. Provide a sufficient number of erection or drift pins, 1/32 in. larger than the bolt diameter.
- H. Paint Markers.** Provide white or yellow paint markers for marking bolts or nuts for wrench calibration, R-C Tests, and bolt installation.

447.3. Equipment.

- A. Testing Equipment.** Provide a calibrated tension-measuring device (Skidmore-Wilhelm or equivalent), calibrated torque wrench, and other accessories necessary to perform the installation verification test and the R-C test and to calibrate hydraulic torque wrenches.
- B. Wrenches.** Furnish either of the following types of wrenches.
 - 1. Air-Driven Impact Wrenches.** Furnish air-driven impact wrenches, air compressors, and related accessories of sufficient capacity to properly tension high-strength bolts. Impact wrenches should be of sufficient size and capacity to be able to tension fully a bolt in less than 15 seconds. Repair or replace any wrenches that are unable to apply full tension to a bolt within this time.

2. **Hydraulic Torque Wrenches.** Furnish a calibrated hydraulic torque wrench, hydraulic pump, and related accessories capable of properly tensioning high-strength bolts. Calibrate the wrench to stall out or cut out completely when the bolt tension reaches 1.05 times the tension specified in Table 1. Calibrate the wrench by tensioning 3 bolts of each size in a calibrated tension-measuring device (Skidmore-Wilhelm or equivalent). When calibrating the wrench, mark each bolt and verify the rotation from snug-tight as specified in Section 447.4.E.1, "Turn-of-the-Nut Method." Calibrate the wrench at least once each working day or as directed. Recalibrate the wrench for changes in bolt diameter; changes in bolt length greater than two bolt diameters; significant differences in the surface condition of the bolts, threads, nuts, or washers; or changes in the equipment or hose length.

447.4. Construction.

A. Equipment Preparation.

1. **Air-Driven Impact Wrench.** Before beginning bolting, perform an installation verification test on 3 complete fastener assemblies of each combination of diameter, length, grade, and lot to be installed. Use the bolting crew that will perform the actual work for the test, and perform the test in the presence of the Engineer. Follow the bolt-tensioning procedures in Section 447.4.E, "Bolt Tensioning." Use a calibrated tension-measuring device (Skidmore-Wilhelm or equivalent) to verify and demonstrate that the method for estimating the snug-tight condition and controlling the turns from snug-tight develops a tension greater than 1.05 times the tension specified in Table 1. The snug-tight condition is defined as the tightness that exists when the plies of the joint are in firm contact.
 2. **Hydraulic Torque Wrench.** Before beginning bolting, calibrate the wrench in accordance with Section 447.3.B.2, "Hydraulic Torque Wrenches." Use the bolting crew that will perform the actual work for the calibration and calibrate the wrench in the presence of the Engineer. Follow the bolt-tensioning procedures in Section 447.4.E, "Bolt Tensioning."
- B. General.** Ensure that all material within the grip of the bolt is steel. Do not allow any compressible material such as gaskets or insulation within the grip. Ensure that the slope of parts in contact with the bolt head or nut does not exceed 1:20 with respect to a plane normal to the

bolt axis. Prepare all joint surfaces, including those in contact with the bolt heads, nuts, or washers, so that the surfaces are free of dirt, loose rust, loose mill scale, burrs, and other matter that would prevent solid seating of the parts.

Replace any bolts and nuts installed for shipping purposes unless the shop drawings indicate that the shop-installed bolts are to be fully tensioned in the shop. Do not tension bolts that have been installed snug-tight in the shop. Remove any bolts installed snug-tight in the shop and replace them with new bolts. Inspect and prepare the joint surfaces after removing shop-installed bolts that are not fully tensioned in the shop.

Provide a hardened washer under either the nut or the bolt head, whichever is turned during tensioning. Install hardened washers under both the nut and bolt head of ASTM A 490 bolts when the outer plies being fastened have a yield strength less than 40 ksi.

Tension all bolts to provide the minimum bolt tension values given in Table 1.

Erect steel in conformance with Item 441, "Steel Structures." Do not tack-weld any parts to eliminate fitup bolts or to hold parts together while bolting.

Table 1
Bolt Tension

Nominal Bolt Size, in.	Minimum Tension (kips)	
	ASTM A 325 Bolts	ASTM A 490 Bolts
1/2	12	15
5/8	19	24
3/4	28	35
7/8	39	49
1	51	64
1-1/8	56	80
1-1/4	71	102
1-3/8	85	121
1-1/2	103	148

- C. Preparation of Faying Surfaces.** If faying surfaces will be painted, ensure that the primer used is documented to have the required slip and creep characteristics to meet the specified mean slip coefficient as

447.4 to 447.4

determined by “Testing Method to Determine the Slip Coefficient for Coatings Used in Bolted Joints” in the Research Council on Structural Connections’ *Specification for Structural Joints Using ASTM A325 or A490 Bolts*. If no mean slip coefficient or corresponding surface condition is specified, do not paint faying surfaces without approval.

Perform blast-cleaning or painting of faying surfaces in accordance with Item 446, “Cleaning and Painting Steel.” Provide an SSPC-SP 10 blast-cleaning if surfaces to be in contact after final bolting will be left unpainted. Do not wire-brush uncoated faying surfaces. Roughen galvanized faying surfaces by hand wire-brushing. Ensure that the required finish exists at the time of bolting.

D. Bolt Installation. Use the following procedure for bolt installation of a complete connection:

- 1. Fair-Up Holes.** Use a minimum number of erection or drift pins, as directed, in the holes to “fair-up” all holes.
- 2. Install Bolts.** Install bolts in all remaining holes of the connection. Do not use excessive force, which results in damage to the threads, to install the bolts. If force is required to install the bolts, increase the number of erection or drift pins as necessary to align the holes. Do not ream the holes unless approved. If approved, ream the holes in accordance with Section 441.3.K.4, “Misfits.” Remove the erection or drift pins and install bolts in these holes. Bring the connection to a full snug-tight condition by snugging systematically from the most rigid part of the connection to the free edges. The snug-tight condition is defined as the tightness that exists when the plies of the joint are in firm, full contact. A snug-tight condition can usually be attained by a few impacts of an impact wrench or the full effort of a worker using an ordinary spud wrench as demonstrated in the installation verification test. As necessary, re-snug previously snugged bolts that may have relaxed as a result of the subsequent snugging of adjacent bolts to insure that all bolts are simultaneously snug-tight and the connection plates are in full contact.

If snugging does not bring the plies of the joint into full contact, fully tighten a minimum number of bolts as directed until the plies are in full contact. Mark these bolts as fitup bolts. A non-galvanized ASTM A 325 bolt of the same diameter may be used as a fitup bolt in connections requiring the use of galvanized ASTM A 325 bolts or ASTM A 490 bolts. Re-snug all remaining bolts.

3. **Tension Bolts.** Tension all bolts other than the fitup bolts in accordance with Section 447.4.E, "Bolt Tensioning." Loosen all fitup bolts after tensioning all the other bolts in the connection. Ungalvanized ASTM A 325 bolts used as fitup bolts may be reused in a connection using this type of bolt. Replace all galvanized bolts and ASTM A 490 bolts used as fitup bolts. Tension these remaining untensioned bolts in accordance with Section 447.4.E.
 4. **Bolt Reuse.** Do not reuse ASTM A 490 or galvanized ASTM A 325 bolts. Ungalvanized ASTM A 325 bolts may be reused one time if the threads have not been damaged. Retensioning previously tensioned bolts loosened by the tensioning of adjacent bolts is not considered to be reuse.
- E. **Bolt Tensioning.** Install bolts and bring them to a snug-tight condition in the sequence described in Section 447.4.D, "Bolt Installation." Use either the turn-of-the-nut method or the calibrated wrench method to tension high-strength bolts. For either method, ensure that the element not turned by the wrench (bolt head or nut) does not rotate.
1. **Turn-of-the-Nut Method.** Match-mark the nuts and the protruding bolt ends after the bolts have been brought up to snug-tight condition and before final tensioning so that actual rotation can be determined. Tension all bolts in the connection to their final tension by the amount of rotation specified in Table 2. Start final tensioning at the center or most rigid part of the connection and progress toward the free edges.
 2. **Calibrated Wrench Method.** Use a calibrated hydraulic torque wrench to tension all bolts to 1.05 times the tension given in Table 1 after they have been brought to the snug-tight condition. Calibrate the wrench in accordance with Section 447.3.B.2, "Hydraulic Torque Wrenches." Start tensioning at the most rigid part of the connection and proceed to the free edges. Return the wrench to re-tension previously tensioned bolts that may have relaxed as a result of the subsequent tensioning of adjacent bolts. Place marks on the socket at one-third points so that the amount of rotation can be visually determined.

**Table 2
Nut Rotation from Snug-Tight Condition¹**

Bolt length (underside of head to end of bolt)	Disposition of Outer Face of Bolted Parts		
	Both faces normal to bolt axis	One face normal to bolt axis and other face sloped less than 1:20 (beveled washer not used)	Both faces sloped less than 1:20 from bolt axis (beveled washer not used)
Up to and including 4 bolt diameters	1/3 turn	1/2 turn	2/3 turn
Over 4 bolt diameters up to and including 8 diameters	1/2 turn	2/3 turn	5/6 turn
Over 8 bolt diameters up to and including 12 diameters ²	2/3 turn	5/6 turn	1 turn

1. Nut rotation is relative regardless of the element (nut or bolt) being turned. The tolerance is $\pm 30^\circ$ for bolts installed by 1/2 turn or less and 45° for bolts installed by 2/3 turn or more.

2. For bolt lengths greater than 12 diameters, determine the required rotation using the installation verification test in a simulated connection of solidly fitted steel.

447.5. Measurement and Payment. Installation and testing of bolts will not be paid for directly but will be subsidiary to the pertinent Items requiring the use of high-strength bolts.

When payment for the structure associated with the bolts is made under Item 442, "Metal for Structures," bolts, nuts, and washers will be paid for in accordance with Item 442.

ITEM 448

STRUCTURAL FIELD WELDING

448.1. Description. Field-weld metal members using the shielded metal arc and flux-cored arc welding processes.

448.2. Materials. Provide electrodes for shielded metal arc welding (SMAW) conforming to the requirements of the latest edition of ANSI/AWS A5.1, "Specifications for Mild Steel Covered Arc Welding

Electrodes,” or ANSI/AWS A5.5, “Specifications for Low-Alloy Steel Covered Arc Welding Electrodes.”

Provide electrodes for flux-cored arc welding (FCAW) conforming to the requirements of the latest edition of ANSI/AWS A5.20, “Specification for Carbon Steel Electrodes for Flux Cored Arc Welding,” or ANSI/AWS A5.29, “Specification for Low-Alloy Steel Electrodes for Flux Cored Arc Welding.”

Provide electrodes and flux-electrode combinations named on the approved list maintained by the Materials and Pavements Section of the Construction Division. To request that a product be added to this list or to renew an expired approval, the Contractor or the consumable manufacturer must submit certified reports of all tests required by the applicable AWS A5 specification according to the applicable welding code to the Construction Division, Materials and Pavements Section. For most structural steel construction, the applicable welding code is AASHTO/AWS D1.5, Bridge Welding Code, or ANSI/AWS D1.1, Structural Welding Code—Steel. For reinforcing steel, the applicable code is ANSI/AWS D1.4, Structural Welding Code—Reinforcing Steel. Tests must be conducted on electrodes of the same class, size, and brand and manufactured by the same process and with the same materials as the electrodes to be furnished. Resubmit electrodes or flux-electrode combinations every 12 months for renewal.

Table 1 shows the classes of electrodes required. Use electrodes with the type of current, with the polarity, and in the positions permitted by AWS A5.1 and A5.5 for SMAW. AWS A5.20 and A5.29 specifications govern for FCAW. Obtain approval for electrode use on steel not listed in Table 1.

Table 1
Classification of Electrodes Permitted

Type of Steel (ASTM Standards)	Electrode Specification	Process	Filler Metal Requirements
Steel piling	AWS A5.1 or A5.5	SMAW	E60XX E70XX or E70XX-X
Armor joints A 500 A 501	AWS A5.20 or A5.29	FCAW	E6XTX-X E7XTX-X (except -2, -3, -10, -GS)
A 36 A 572 Gr. 50 A 588	AWS A5.1 or A5.5	SMAW	E7016 E7018 E7028
A 242 A 709 Gr. 36, 50, or 50S	AWS A5.20 or A5.29	FCAW	E7XT-1 E7XT-5 E7XT-6 E7XT-8
Weathering steel A 588 A 242 A 709 Gr. 50W	AWS A5.5	SMAW	E8018-W E8016-C3 E8018-C3 E8016-C1 E8018-C1 E8016-C2 E8018-C2
	AWS 5.29	FCAW	E8XT1-W E8XTX-Ni1 E8XTX-Ni2 E8XTX-Ni3
A 709 Gr. HPS 70W	AWS A5.5	SMAW	E9018-M-H8R
Reinforcing steel Grade 40	AWS A5.1 or A5.5	SMAW	E70XX
Reinforcing steel Grade 60	AWS A5.5	SMAW	E90XX
Permanent metal deck forms	AWS A5.1 or A5.5	SMAW	E6010 E6011 E6013 E7018

Note: Low-hydrogen electrodes applicable to the lower strength base metal may be used in joints involving base metals of different yield points or strengths.

E7010 and E8010 electrodes may be used when welding the root passes of beam and girder splices if the requirements of Section 448.4.C.5.a, “High-Cellulose Electrodes for Root Passes,” are met.

When welding fracture-critical applications, use electrodes meeting the diffusible hydrogen requirements for fracture-critical welding in AASHTO/AWS D1.5.

For FCAW, use gas or gas mixtures that are welding grade and have a dew point of -40°F or lower. Furnish certification to the Engineer that the gas or gas mixture is suitable for the intended application and will meet the dew point requirements.

448.3. Equipment. Provide electrode drying and storing ovens that can maintain the required temperatures specified in Section 448.4.C.1, “Electrode Condition,” along with thermometers for checking and controlling the oven temperatures. Provide preheating equipment that can maintain the entire joint at or above the specified temperature. Provide approved equipment for checking preheat and interpass temperatures at all times while welding is in progress. Provide welding equipment meeting the requirements of the approved welding procedure specification (WPS), if required, and capable of making consistent high-quality welds.

448.4. Construction.

A. Procedure Qualification. Use the proper classification and size of electrode, arc length, voltage, and amperage for the thickness of the material, type of groove, welding positions, and other circumstances of the work.

Submit WPS’s for FCAW, qualified in accordance with AASHTO/AWS D1.5, for approval before any field welding on a project.

B. Welder Qualification. Provide Department certification papers for each welder for each welding process to be used before welding, except for miscellaneous welds described in Section 448.4.B.1.a, “Miscellaneous Welding Applications.” Certification is issued by the Department as described in Section 448.4.B.2, “Certified Steel Structures Welder.”

1. Miscellaneous Welding. A qualified welder is an experienced welder who is capable of making welds of sound quality but does not have Department certification papers. Before welding begins, the Engineer will check the welder’s ability by conducting a job-site test in accordance with Section 448.4.B.1.b, “Miscellaneous

Weld Qualification Test.” Furnish all materials and equipment necessary for this test.

- a. Miscellaneous Welding Applications.** A welder certified for structural or reinforcing steel or a qualified welder may make miscellaneous welds of the following types:
- splicing reinforcing steel to extend bars in the bottom of a drilled shaft;
 - attaching chairs to the reinforcing steel cage of a drilled shaft;
 - armor joints and their supports;
 - screed rail and form hanger supports where permitted on steel units;
 - reinforcing steel to R-bars for lateral stability between prestressed beams, spirals, or bands to reinforcing bars in drilled shaft cages;
 - permanent metal deck forms;
 - additional steel added in railing when slip-form construction is used; and
 - other similar miscellaneous members that have no load-carrying capacity in the completed structure.
- b. Miscellaneous Weld Qualification Test.** A qualified welder must pass a job-site Miscellaneous Weld Qualification Test before welding:
- Make a single-pass fillet weld of 1/4-in. maximum size in the vertical position approximately 2 in. long on 1/2-in. plate in the location shown in Figure 1. Use the same electrode proposed for the work.
 - The Engineer will visually inspect the fillet weld for a reasonably uniform appearance and then rupture the weld as shown in Figure 2 with a force or by striking it with a hammer.
 - The fractured surface of the weld will be inspected to ensure complete penetration into the root of the joint, complete fusion to the base metal, and no inclusion or porosity larger than 3/32 in. in its greatest dimension.

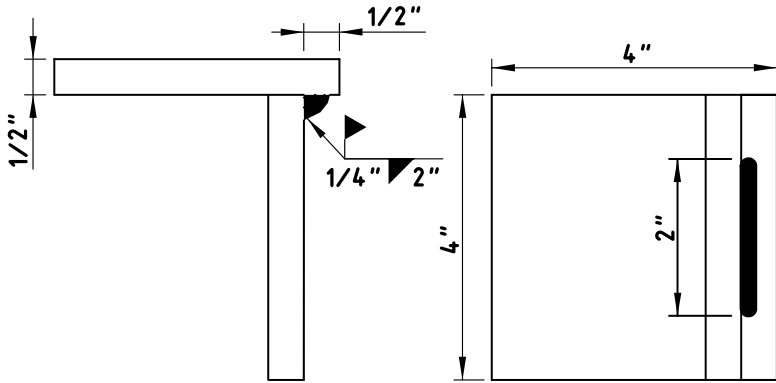

Figure 1
Miscellaneous qualification—fillet weld break specimen.

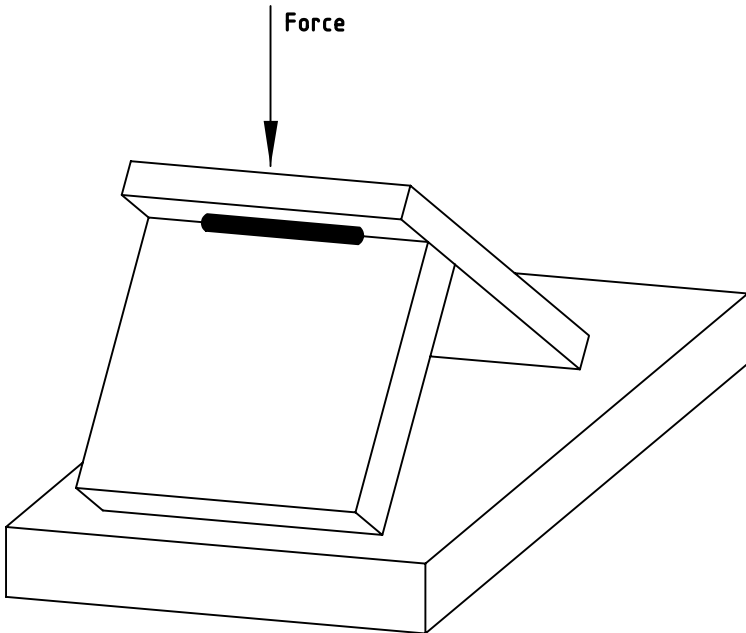

Figure 2
Miscellaneous qualification—method of rupturing specimen.

A welder who fails the Miscellaneous Weld Qualification Test may take a retest under the following conditions:

- The retest occurs immediately and consists of 2 test welds as described above with both test specimens meeting all of the requirements.
- The retest occurs after 30 days if the welder provides evidence of further training or practice. In this case the test consists of a single test weld.

Qualification by the Miscellaneous Weld Qualification Test is effective immediately upon satisfactory completion of the test and remains in effect for the duration of a project.

2. **Certified Steel Structures Welder.** Before making non-miscellaneous welds on structural steel, a welder must pass the AASHTO/AWS D1.5 qualification test for groove welds for plates of unlimited thickness in the vertical (3G) and overhead (4G) positions with the following additional requirements:

- Use metal for test plates that meets Item 442, “Metal for Structures,” with a minimum yield point of 50 ksi.
- Use approved electrodes meeting the required class in accordance with Table 1 and, in the case of FCAW, in accordance with the approved WPS.
- Have a radiographic inspection performed on the weld on each test plate. Any porosity or fusion-type discontinuity with greatest dimension larger than 1/16 in. found in the weld will result in failure of the test. Discontinuities with greatest dimension less than 1/16 in. are acceptable provided the sum of their greatest dimensions does not exceed 3/8 in. in any inch of weld.
- Have two side-bend specimens prepared, tested, and inspected for each test plate.

The test must be administered by an approved laboratory. Submit 2 copies of the certification issued by the laboratory, all accompanying test papers, and the radiographic films to the Bridge Division for review. The Bridge Division issues Department certification papers if the laboratory’s certification is approved. A welder must also demonstrate to the Engineer a thorough knowledge of the required welding procedures together with the ability and desire to follow them and make welds of sound quality and good appearance. The certification issued by an approved laboratory is accepted for 1 month from the time of certification, during which time the welder may work on Department projects if

the work is satisfactory. Certification papers issued by the Department remain in effect as long as the welder performs acceptable work as determined by the Bridge Division. The certification may be cancelled at any time if the welder's work is not acceptable.

For SMAW, a welder certified using EXX18 electrodes is qualified to weld with all approved SMAW electrodes up to E90XX to join metals with a maximum specified yield strength of 65 ksi.

C. Welding Steel Structures.

1. Electrode Condition.

- a. **SMAW.** For electrodes with low-hydrogen coverings conforming to AWS A5.1, dry in conformance with the manufacturer's written drying instructions or dry for at least 2 hours between 450°F and 500°F. For electrodes with low-hydrogen coverings conforming to AWS A5.5, dry for at least 1 hour between 700°F and 800°F or as specified by the electrode manufacturer. If using electrodes from a newly opened undamaged hermetically sealed container, drying is not required. Immediately after drying or removal from hermetically sealed container, store electrodes in ovens held at a temperature of at least 250°F. Elapsed time permitted between removal of an electrode from the storage oven or hermetically sealed container and use of the electrode is given in Table 2.

Table 2
SMAW Electrode Exposure Limits

Electrode Type	Exposure Time (hours)
E70	4
E80	2
E90	1

If electrodes are placed back in the holding oven before the times given in Table 2 have lapsed, leave them in for at least 4 hours at 250°F before reusing. The Engineer may reduce times allowed for use without redrying in humid atmospheres. Do not redry electrodes more than once. Do not use electrodes with flux that has been wet, cracked, or otherwise damaged.

- b. **FCAW.** Protect or store welding wire coils removed from the original package to keep their characteristics or welding

properties intact. Do not use coils or portions of coils that are rusty.

- c. **Special Applications.** For fracture-critical applications or when welding steel not shown in Table 1, dry electrodes in accordance with the manufacturer's specifications and AASHTO/AWS D1.5.
2. **Environmental Conditions.** Do not weld when the air temperature is lower than 20°F; when surfaces are wet or exposed to rain, snow, or wind; or when operators are exposed to inclement conditions. Provide wind breaks to protect welding operations from winds greater than 5 MPH.
3. **Assembly and Fitup.** Verify that ends of members to be welded are prepared in accordance with the welded joint detail specified. For girder splices, see Figures 3, 4, and 5 for proper end preparation and weld details.

Bring the parts to be joined by fillet welds into as close contact as possible, not separated more than 3/16 in. If the separation is 1/16 in. or more, increase the leg of the fillet weld by the amount of the separation. Keep the separation between faying surfaces of lap joints and of butt joints landing on backing strips to no more than 1/16 in.

Make suitable allowance for shrinkage, and never restrain the joint on both sides in any welding process.

Use the following fitup procedure for groove welds for butt joints:

- Align splices of beams and girders joined by groove welds with the center of gravity of both cross sections coinciding or each flange vertically offset equally. Fit beams and girders with offset webs with the webs aligned and the flanges offset laterally. When flanges are offset or abutting parts differ in thickness or width by more than 1/8 in., make the joint with a smooth transition between offset surfaces and with a slope of no more than 1:4.
- Space members to provide a 3/16-in. root opening at the nearest point. At other points of the joint when the spacing provides up to a 7/16-in. opening, correction may be made by buildup up to 1/8 in. on each bevel nose. Rebevel openings exceeding 7/16 in. and move the parts to be joined closer together to bring the joint within the maximum buildup limits. Allow buildups to cool to the maximum preheat and interpass temperatures before welding the joint.

- Bring all members into correct alignment and hold them in position by acceptable clamps while welding.

Complete all butt splices before welding diaphragms or sway bracing in a particular section of a unit. Diaphragms and sway bracing may be welded in a unit behind the splice welding to provide stability except where such welding interferes with butt splice adjustments, such as at a drop-in segment of a continuous unit. Complete all splices before welding beams or girders to shoes.

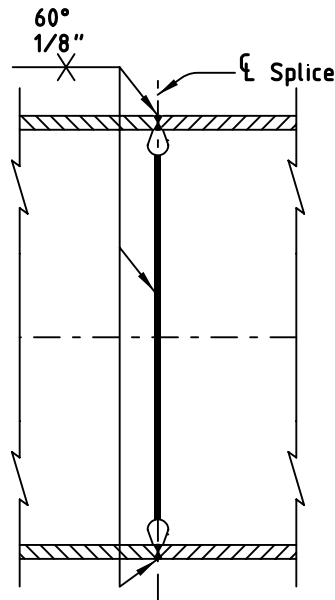

Figure 3
Girder splice details.

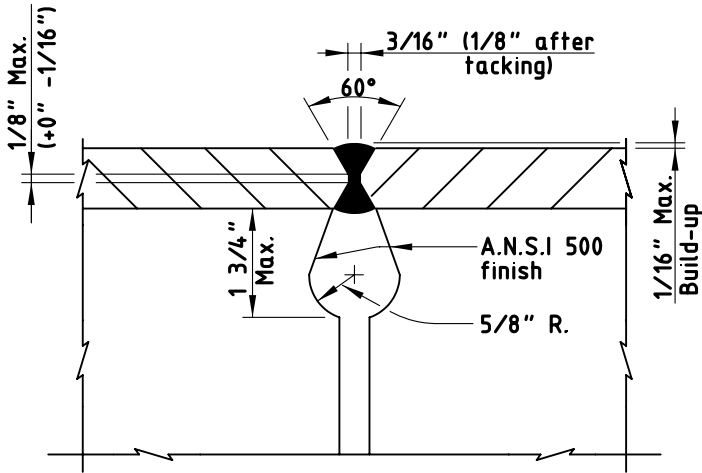

Figure 4
Girder splice details (flange).

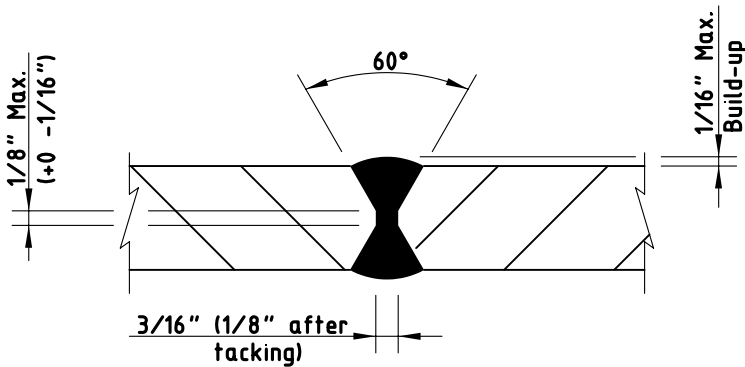

Figure 5
Girder splice details (web).

4. **Preheat.** Preheat ahead of welding both groove and fillet welds (including tack welding) to the temperatures shown in Table 3. Keep preheat and interpass temperatures high enough to prevent cracks. The preheat temperatures shown in Table 3 are minimums, and higher preheats may be necessary in highly restrained welds. When the base metal is below the required temperature, preheat it so that parts being welded are not cooler than the specified temperature within 3 in. of the point of welding.

Measure preheat temperature on the side opposite to which the heat is applied at points approximately 3 in. away from the joint.

When possible, completely weld a joint before allowing it to cool below the specified temperature. Always deposit enough weld to prevent cracking before allowing a joint to cool. Do not allow preheat and interpass temperatures to exceed 400°F for thickness up to 1-1/2 in. and 450°F for greater thicknesses.

Table 3
Minimum Preheat and Interpass Temperature
for Welding with Low-Hydrogen Electrodes

Thickest Part at Point of Welding	Temperature
Up to 3/4 in., inclusive	50°F
More than 3/4 in. up to 1-1/2 in., inclusive	70°F
More than 1-1/2 in. up to 2-1/2 in., inclusive	150°F
More than 2-1/2 in.	225°F

When E7010 or E8010 electrodes are used for tacking or temporary root pass, preheat the material in accordance with Table 4.

Table 4
Minimum Preheat Temperature for Welding
with E7010 or E8010 Electrodes

Thickest Part at Point of Welding	Temperature
1/2 in. and less	150°F
9/16 in. through 3/4 in.	200°F
13/16 in. through 1-1/2 in.	300°F
More than 1-1/2 in.	400°F

Use preheat and interpass temperatures for the thicker plate thickness when joining steels of different thickness.

When the base metal temperature is below 32°F, preheat to at least 70°F and maintain this minimum temperature during welding. If the base metal is moist, preheat it to 200°F before starting to weld.

- 5. Welding Practice.** Use an approved procedure to control shrinkage and distortion. For FCAW, weld in accordance with an approved WPS. Weld as required by the Contract or erection drawings. Do not change the location or size of welds without approval. Do not make temporary welds for transportation, erection, or other purposes on main members except as shown on

the plans or approved. Use a crayon, paint, or other approved method to mark each groove weld to identify the welder who performed the work.

Use the stringer-bead technique where possible for groove welds. In vertical welding passes, progress upward using a back-step sequence.

Begin and terminate groove welds at the ends of a joint on extension bars. Make edge preparation and thickness of extension bars the same as that of the member being welded but extending at least 2 in. beyond the joint. After the weld is completed and cooled, remove extension bars with a cutting torch or arc-air gouging, and grind the flange edges smooth. If any defects are exposed by the grinding, clean them, fill them with weld metal, and regrind them to a uniform finish. Grind so that grind marks are parallel to the flange, and avoid excess grinding of the parent metal. Clean and fuse tack welds thoroughly with the final weld. Remove defective, cracked, or broken tack welds.

Gouge, chip, or otherwise remove the root of the initial weld to sound metal for all groove welds, except those produced with the aid of backing or those on steel piling or armor joints, before welding is started on the second side. Thoroughly clean the back side before placing the backup pass. For groove welds made with steel backing, thoroughly fuse the weld metal with the backing, and use backing that is continuous for the full length of the weld. Make a continuous length of backing by welding shorter sections together only under the following conditions:

- All splices in the backing are complete joint penetration (CJP) groove welds made with the same controls as similar CJP groove welds in the structure.
 - The welds are radiographed and examined as described in Section 448.4.C.7, “Radiographic Inspection,” to ensure weld soundness.
 - All welding and testing of the backing is complete before the backing is used to make the structural weld.
- a. **High-Cellulose Electrodes for Root Passes.** E7010 and E8010 electrodes may be used when welding the root passes of beam and girder splices if the work is preheated in accordance with Table 4. After the root passes are backed up, completely remove the E7010 or E8010 electrode pass by arc-air gouging, and replace it using a low-hydrogen electrode.

- b. Welding Sequence.** Make beam and girder splices using the sequences shown in Figure 6. (Some members will require fewer or more passes than Figure 6 shows.) Alternate welds from flat to overhead to prevent heat buildup along bevel edge. Arrange the passes between the top and bottom flange to maintain balance and symmetry.

For both rolled I-beams and built-up girders, place passes 1, 2, and 3 in the top flange, followed by passes 4, 5, and 6 in the bottom flange (see Figure 6). Gouge out and replace passes 1 and 4, which always are placed in the overhead position. Next, place passes 7, 8, and 9 in the top flange, followed by passes 10, 11, and 12 in the bottom flange. Continue with placing passes 13–17 in the top flange, followed by passes 18–22 in the bottom flange. Continue to alternate welding between top and bottom flange with a maximum of 5 passes per flange until the flange splices are complete. Tack weld web after aligning girder webs with short tacks as required to obtain proper alignment. Place pass 23 and pass 24 on the web. Gouge out and replace pass 23. Finish web splice with pass 25.

For each layer, each bead, and the crater area, remove all slag and clean the weld and adjacent base metal before welding over previously deposited metal. Avoid arc strikes, and if they occur, grind resulting cracks and blemishes out to a smooth contour and check them visually to ensure soundness.

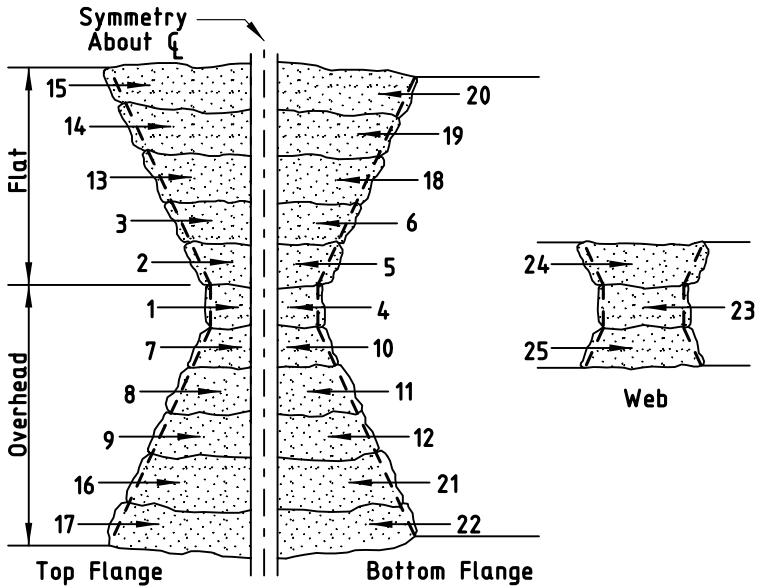

Figure 6
Welding sequence for splices for material up to
50,000-psi yield strength.

Deviation from the above sequence of weld passes requires approval. Obtain approval from the Bridge Division for welding procedures and sequences for special connections.

c. Electrode Size and Weld Layer Thickness.

(1) SMAW.

(a) Electrode Size. Use electrodes with the following maximum size:

- 1/4 in. for all welds made in the flat position except root passes,
- 1/4 in. for horizontal fillet welds,
- 1/4 in. for root passes of fillet welds made in the flat position and of groove welds made in the flat position with backing and with a root opening of 1/4 in. or more,

- 5/32 in. for welds made with low hydrogen electrodes in the vertical and overhead positions, and
- 3/16 in. for all other welds.

(b) Weld Size and Layer Thickness. Make the root pass large enough to prevent cracking. Make layers subsequent to the root pass in fillet welds and all layers in groove welds of the following maximum thickness:

- 1/4 in. for root passes of groove welds;
- 1/8 in. for subsequent layers of welds made in the flat position; and
- 3/16 in. for subsequent layers of welds made in the vertical, overhead, and horizontal positions.

Make fillet welds passes no larger than:

- 3/8 in. in the flat position,
- 5/16 in. in the horizontal or overhead positions, and
- 1/2 in. in the vertical position.

(2) FCAW.

(a) Electrode Size. Use electrodes with the following maximum size:

- 5/32 in. for the flat and horizontal positions,
- 3/32 in. for the vertical position, and
- 5/64 in. for the overhead position.

(b) Weld Size and Layer Thickness. Make weld layers, except root and surface layers, no thicker than 1/4 in. When the root opening of a groove weld is 1/2 in. or wider, use a multiple-pass split-layer technique. Use the split-layer technique to make all multiple-pass welds when the width of the layer exceeds 5/8 in.

Ensure that each pass has complete fusion with adjacent base metal and weld metal and that there is no overlap, excessive porosity, or undercutting.

Do not use FCAW with external gas shielding in a draft or wind. Furnish an approved shelter of material and shape to reduce wind velocity near the welding to a maximum of 5 MPH.

Make fillet weld passes no larger than:

- 1/2 in. in the flat position,
- 3/8 in. in the horizontal or overhead positions, and
- 5/16 in. in the vertical position.

6. **Weld Quality.** Provide welds that are sound throughout with no cracks in the weld metal or weld pass. Completely fuse the weld metal and the base metal and each subsequent pass. Keep welds free from overlap, and keep the base metal free from undercut more than 1/100 in. deep when the direction of undercut is transverse to the primary stress in the part that is undercut. Fill all craters to the full cross section of the welds.

7. **Radiographic Inspection.** Conduct radiographic testing (RT) as required in the field at the expense of the Contractor by an agency or individual registered and licensed to perform industrial radiography. Follow all applicable rules and regulations for radiographic operations. Testing includes furnishing all materials, equipment, tools, labor, and incidentals necessary to perform the required testing. The Department may require further tests in accordance with Article 5.7, "Inspection," and may perform additional testing, including other methods of inspection.

Perform RT in accordance with AASHTO/AWS D1.5. The Engineer will examine and interpret the resulting radiographs in accordance with AASHTO/AWS D1.5. All radiographs become the property of the Department and remain with the Engineer.

For field welds of splices in beams or girders, radiographically inspect the full flange width of all flange splices and the top and bottom 1/6 of the web at each splice. Radiographically retest repaired welds. Make necessary repairs before any further work is done. Additional RT required because of unacceptable welding or poor radiograph quality is at the Contractor's expense. RT of particular welds required by the plans is in addition to the RT required by this Item.

8. **Corrections.** When welding is unsatisfactory or indicates inferior workmanship, the Engineer will require corrective measures and approve the subsequent corrections.

Use oxygen gouging or arc-air gouging when required to remove part of the weld or base metal. Do not use oxygen gouging on weathering steel. Backgouge splices in beams and girders or cut out defective welds using arc-air gouging by a welder qualified to make beam and girder splices.

Where corrections require depositing additional weld metal, slope the sides of the area to be welded enough to permit depositing new metal.

Where corrections require depositing additional weld metal, use a smaller electrode than that used for the original weld. Clean surfaces thoroughly before rewelding.

Remove cracked welds completely and repair. If crack length is less than half the length of the weld, remove the weld metal for the length of the crack plus 2 in. beyond each end of the crack, and repair.

Where work performed after making a deficient weld has made the weld inaccessible or has caused new conditions making the correction of the deficiency dangerous or ineffectual, restore the original conditions by removing welds, members, or both before making the necessary corrections; otherwise, compensate for the deficiency by performing additional work according to a revised and approved design.

Cut apart and reweld improperly fitted or misaligned parts.

Straighten members distorted by the heat of welding using mechanical means or the carefully supervised application of a limited amount of localized heat. Do not let heated areas exceed 1,200°F as measured by temperature-indicating crayons or other approved methods for steel up to 65,000 psi yield strength. Do not let heated areas exceed 1,100°F for higher-strength steels. Keep parts to be heat-straightened substantially free of stress from external forces except when mechanical means are used with the application of heat. Before straightening, submit a straightening procedure to the Engineer for approval.

Correct defective or unsound welds either by removing and replacing the entire weld or as follows.

- a. **Excessive Convexity.** Reduce to size by grinding off the excess weld metal, leaving a smooth profile.
- b. **Shrinkage Cracks, Cracks in Base Metal, Craters, and Excessive Porosity.** Remove defective portions of base and weld metal down to sound metal, and replace with additional sound weld metal.
- c. **Undercut, Undersize, and Excessive Concavity.** Clean and deposit additional weld metal.

- d. **Overlap and Incomplete Fusion.** Remove and replace the defective portion of weld.
 - e. **Slag Inclusions.** Remove the parts of the weld containing slag, and replace them with sound weld metal.
 - f. **Removal of Base Metal during Welding.** Clean and form full size by depositing additional weld metal using stringer beads.
- D. Welding Reinforcing Steel.** Splice reinforcing steel by welding only at locations shown on the plans.
1. **Base Metal.** Provide weldable reinforcing steel in conformance with Item 440, "Reinforcing Steel."
 2. **Preheat and Interpass Temperature.** Minimum preheat and interpass temperatures are shown in Table 5. When reinforcing steel is below the listed temperature for the size and carbon equivalency range of the bar being welded, preheat it so that the cross section of the bar is above the minimum temperature for at least 6 in. on each side of the joint. After welding is complete, allow bars to cool naturally to ambient temperature. Do not accelerate cooling.

Table 5
Minimum Preheat and Interpass Temperature for Reinforcing Steel

Carbon Equivalent Range (%)	Size of Reinforcing Bar (no.)	Temperature (°F)
Up to and including 0.40	Up to 11 inclusive	None
	14 and 18	50
0.41 through 0.45 inclusive	Up to 11 inclusive	None
	14 and 18	100
0.46 through 0.55 inclusive	Up to 6 inclusive	None
	7 to 11 inclusive	50
	14 and 18	200
Unknown	Up to 18 inclusive	500

For widening projects, base the preheat and interpass temperatures on the existing reinforcing steel and the requirements of Table 5.

3. **Joint Types.** Use butt splices for all No. 7 and larger bars. Use lap splices for No. 6 and smaller bars.

Make groove welds in lap splices at least 4 in. long, and weld them on each side of the lap joint as shown in Figure 7. For No. 5 and

smaller bars, weld from one side of the lap when it is impractical to weld from both sides of the joint if approved by the Engineer, but in this case make the weld at least 6 in. long.

Where possible, make all butt splices in the flat position. Make all welds for butt splices, except horizontal welds on vertical bars, as shown in Figures 8 and 9. The back-up strip is required when access to the splice is from the top only. When bars can be rotated or access to the splice is available from two sides, the double bevel splice may be used, and this type weld requires gouging out the root pass similar to a flange splice on structural steel. The root pass may be made using E7010 or E8010 electrodes for all double beveled splices. If using E7010 or E8010 electrodes, preheat the steel to 400°F and then completely remove the root pass before welding the opposite side. Make horizontal splices on vertical bars as shown in Figure 10. Provide alignment strips as shown in Figures 9 and 10 to hold bars during welding operation. Trim alignment strips after welding is complete.

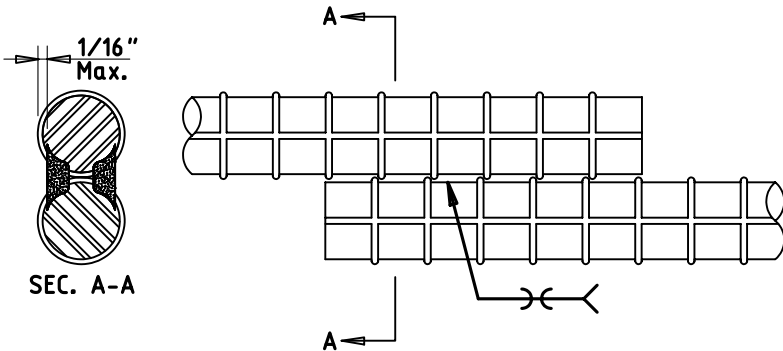

Figure 7
Direct lap joint with bars in contact.

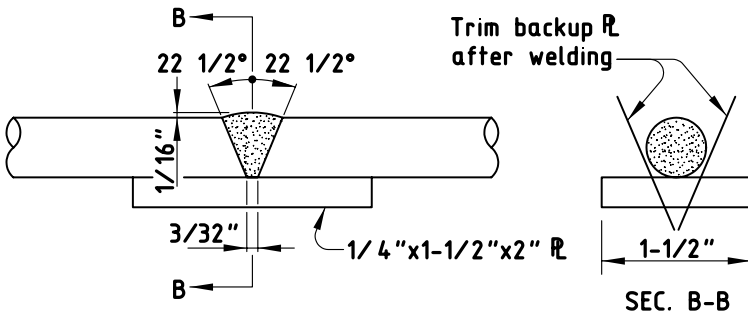

Figure 8
Single bevel V-groove weld in horizontal position.

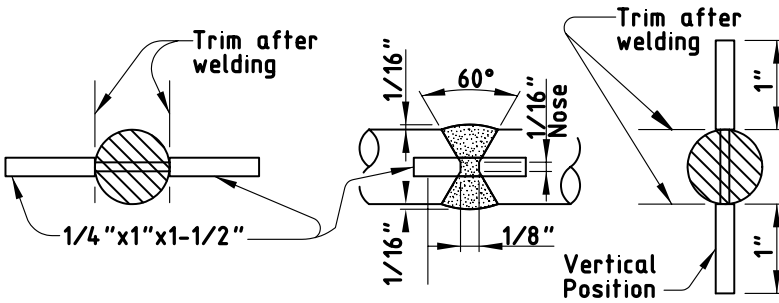

Figure 9
Double bevel V-groove weld in horizontal position.

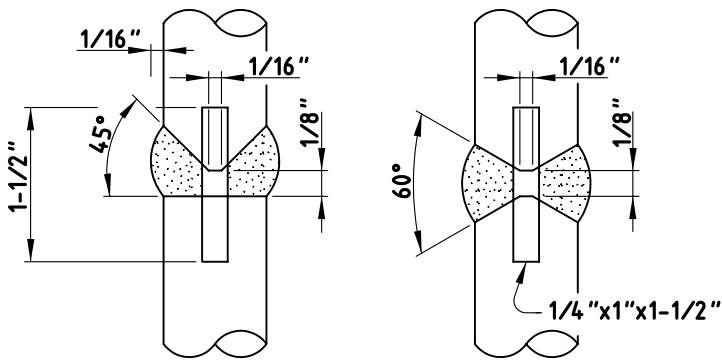

Figure 10
Double bevel V-groove weld in vertical position.

4. **Radiographic Inspection.** Radiograph welded butt splices at the expense of the Contractor when designated on the plans. Follow all applicable rules and regulations for radiographic operations. Ensure that welds have no cracks and that the sum of the greatest dimensions of porosity and fusion-type defects do not exceed 1/10 of the nominal bar diameter.

The Engineer examines and interprets the resulting radiographs, which become the property of the Department and remain with the Engineer.

448.5. Measurement and Payment. The work performed, materials furnished, equipment, labor, tools, and incidentals will not be measured or paid for directly but will be subsidiary to pertinent Items.

ITEM 449 ANCHOR BOLTS

449.1. Description. Fabricate and install anchor bolts to be embedded in or attached to concrete.

449.2 to 449.3

449.2. Materials.

- A. Bolts and Nuts.** Provide bolts and nuts that meet the standards given in Table 1.

Table 1
Bolt and Nut Standards

Specified Anchor Bolt Category	Bolt Standards	Nut Standards
Mild steel	ASTM A 307 Gr. A or A 36	ASTM A 563
Medium-strength, mild steel	ASTM F 1554 Gr. 55 with supplementary requirement S1	ASTM A 194 Gr. 2H or A 563 Gr. D or better
High-strength steel	ASTM A 325 or A 321	ASTM A 194 or A 563, heavy hex
Alloy steel	ASTM A 193 Gr. B7	ASTM A 194 Gr. 2H or A 563 Gr. DH, heavy hex

Provide a mill test report or manufacturer's certification indicating that the material conforms to these requirements. For alloy steel anchor bolts, provide a test report or certification attesting to the heat treating process. If no specific bolt category is indicated on the plans, provide mild steel anchor bolts with nuts that meet ASTM A 563.

- B. Washers.** Use washers that meet ASTM F 436.
- C. Threads.** Provide anchor bolts with rolled or cut threads of UNC or 8UN series in accordance with ASME B1.1. Anchor bolts larger than 2 in. in diameter must have UNC series threads. If bolts have rolled threads, ensure that the diameter of the unthreaded portion is neither less than the minimum pitch diameter nor more than the maximum major diameter of the threads. If bolts have cut threads, ensure that the diameter of the unthreaded portion is not less than the minimum major diameter of the threads. Ensure that all threads for bolts and nuts have Class 2 fit tolerances in accordance with ASME B1.1.

449.3. Construction.

- A. Fabrication.** Welded splicing of anchor bolts is not permitted.

Provide an anchorage device with each anchor bolt consisting of a standard bolt head, a threaded bolt with nut, or, if shown on the plans, a 90° bend. Make the inside-bend diameter approximately 2 times the anchor bolt diameter, but at no point along the bend greater than 3 times the bolt diameter. Hot bending is permissible provided the temperature does not exceed 1,100°F.

If the anchor bolts will be installed in a template embedded in concrete, tack-weld the anchorage nuts to the template in the shop. Perform this welding with appropriate jigs to ensure that the anchor bolt is perpendicular to the template.

When embedded templates are not specified and nuts are welded to the end of anchor bolts for anchorage, weld only on the nut face at the unstressed end of the bolt. Ensure that no welding, arc, or other potential notch-producing effects occur in the stressed portion of the bolt.

Shipping of the anchor bolt cage in its assembled condition is not required.

- B. Finish.** Galvanize in accordance with Item 445, “Galvanizing.”
- 1. Anchor Bolts Embedded in Concrete.** Galvanize the exposed end plus a minimum of 6 in., unless otherwise shown on the plans.
 - 2. Anchor Bolts Extending Through Concrete.** Galvanize the complete length of the bolt.
 - 3. Nuts.** Galvanize exposed nuts. Galvanize the untapped blanks before cutting the threads.
 - 4. Washers.** Galvanize exposed washers.
- C. Installation.** Hold the anchor bolt and template assembly rigidly in position during concrete placement. Use wood templates or other positive means to ensure correct positioning of anchor bolts not requiring steel templates. Positioning devices may be tack-welded to the steel templates but not to any portion of the anchor bolts.
- 1. Anchor Bolt Thread Lubricant Coating.** For traffic signal poles, roadway illumination poles, high mast illumination poles, and overhead sign support structures, coat anchor bolt threads before installing nuts with an electrically conducting lubricant compound described in Section 449.3.C.2.a, “Definitions.” Coat anchor bolt threads for other structures with pipe joint compound or beeswax. After installing nuts, repair galvanizing damage on bolts, nuts, and washers in accordance with Section 445.3.D, “Repairs.”
 - 2. Anchor Bolt Tightening Procedure.** Tighten anchor bolts for traffic signal poles, roadway illumination poles with shoe bases, high mast illumination poles, and overhead sign support structures in accordance with this Section. This procedure covers the tightening of nuts on a double-nut anchor bolt system using anchor

bolts with 55-ksi or 105-ksi minimum yield strength and UNC or 8UN thread series to secure structures to drilled shaft foundations.

a. Definitions. The following definitions apply to the anchor bolt tightening procedure:

- **Double-nut anchor bolt system.** An anchor bolt with 2 nuts that sandwich the structure's base plate. The bottom nut is positioned under the base plate to level, support, and provide the reaction for the force applied by tightening the top nut positioned above the base plate.
- **Electrically conducting lubricant.** A compound commonly used in the electrical industry to coat threads of field-cut rigid metal conduit and suitable for exposure to weather.
- **Impact tightening.** The tightening of nuts with a box end "slug" or "knocker" wrench and a sledgehammer. The wrench, matching the size of the nut to be tightened, is driven with the sledgehammer to rotate the nut.
- **Static tightening.** The tightening of nuts with a "spud" wrench and a pipe or extension handle. The wrench, matching the size of the nut to be tightened, may be turned with more than one worker to rotate the nut.
- **Snug-tight.** The condition when the nut is in full contact with the base plate. It may be assumed that the full effort of a worker on a 12-in. wrench results in a snug-tight condition.
- **Turn-of-the-nut method.** The tightening of top nuts to snug-tight condition then establishing reference positions by marking one flat on each nut with a corresponding reference mark on the base plate at each bolt. Each nut is then turned to the prescribed rotation from the referenced snug tight position.

b. Anchor Bolt Tightening. Perform the following procedure:

- (1) Coat the threads of the anchor bolts with electrically conducting lubricant.
- (2) Install the bottom nuts on the bolts, 1 on each bolt.
- (3) Using the top template as a guide, level the top template by adjusting the bottom nuts so that the template rests on each nut and the distance between the top of the concrete shaft and the bottom surface of the bottom nut is approximately 1/2 in.

- (4) Remove the template.
- (5) Coat the bearing surfaces of the bottom nuts and washers with electrically conducting lubricant.
- (6) Install bottom washers on bolts, 1 on each bolt.
- (7) Erect and plumb the structure as specified. Adjust the bottom nuts so that each is bearing equally on the washer or base plate. The truss for cantilever overhead sign support structures and the mast arm for traffic signal poles must be removed during anchor bolt tightening.
- (8) With the plumbed structure supported by a crane, coat the bearing surfaces of the top nuts and washers with electrically conducting lubricant. Install 1 washer and 1 top nut on each bolt. Turn the top nuts onto the bolts so that each is hand-tight against the washer or base plate.
- (9) Using a wrench, turn each bottom nut to a snug-tight condition.
- (10) Verify that the structure is still plumb and still supported by the crane. Begin turn-of-the-nut method by turning each top nut down to the same snug tight condition. Prevent rotation of the bottom leveling nut during all top nut tightening. Once snug-tight condition is achieved, establish reference marks for turn-of-the-nut method and then tighten the top nuts by turning each nut $1/12$ turn ($1/2$ of a nut flat) past snug-tight using either static or impact tightening. Turn each top nut an additional $1/12$ turn until each nut has been tightened $1/6$ total turn past snug-tight.

449.4. Measurement and Payment. Top or bottom templates, washers, lock washers, nuts, lock nuts, and other devices used for installing anchor bolts are considered part of the anchor bolt assembly. All work performed, materials furnished, equipment, labor, tools, and incidentals will not be measured or paid for directly but will be subsidiary to pertinent Items.

450.1 to 450.3

ITEM 450 RAILING

450.1. Description. Construct railing of concrete, steel, aluminum, or a combination of these materials, including necessary anchorage for the railing on bridges, culverts, walls, or other structures as shown on the plans.

450.2. Materials. Use materials that conform to requirements of the following Items:

- Item 421, “Hydraulic Cement Concrete”
- Item 440, “Reinforcing Steel”
- Item 442, “Metal for Structures”
- Item 445, “Galvanizing”
- Item 446, “Cleaning and Painting Steel”
- Item 540, “Metal Beam Guard Fence.”

450.3. Construction. Construct railing in accordance with details, alignment, and grade designated on the plans. Unless otherwise directed, do not place railing until falsework or formwork, if any, for the span has been released. During construction, ensure that expansion joints in the railing will function properly after the railing is installed.

If the plans allow either steel or aluminum options for a particular railing type, furnish either steel or aluminum but not both for the entire Contract.

A. Metal Railing.

1. **General.** Furnish metal beam rail elements in accordance with Item 540, “Metal Beam Guard Fence.”

Fabricate and erect metal railing according to the pertinent provisions of Item 441, “Steel Structures,” and the requirements of this Item.

When required by the plans, prepare and submit for approval the required shop or erection drawings in accordance with Item 441. Show all splice locations and details on the shop or erection drawings. Splice members only as provided on the plans.

Field weld when required in accordance with Item 448, “Structural Field Welding.”

2. **Fabrication.** Fabricate metal railing and post panels in sections conforming to the details shown in the plans and field-verified lines and grades. Fabricate adjacent sections so that they will accurately engage each other in the field. Match mark each pair of

sections so they can be erected in the same position in which they were fabricated.

Fabricate metal rail elements included as part of the railing system to the dimensions and cross-sections shown on the plans and within a tolerance of 1/4 in. per 10 ft. in the straightness of either edge. Joint and connect metal rail elements to the rail posts as shown on the plans, lapping metal rail elements in the direction of traffic in the adjacent lane. Unless otherwise shown on the plans, bolts and nuts for metal railing should meet requirements of ASTM A 307 and be galvanized in accordance with Item 445, "Galvanizing."

Fabricate aluminum in accordance with AWS D1.2, *Structural Welding Code—Aluminum*.

To facilitate bending or straightening, aluminum materials other than castings may be heated to a temperature up to 400°F for no more than 30 min.

3. **Castings.** Provide permanent mold castings of the materials specified that are true to pattern in form and dimensions and of uniform quality and condition. Castings must be free from cracks and defects such as blowholes, porosity, hard-spots, or shrinkage that could affect their suitability for use. Repair minor defects in aluminum castings by an approved inert gas-welding process. Ensure that finished castings are free of burrs, fins, discoloration, and mold marks and that they have a uniform appearance and texture.

Produce castings under radiographic control sufficient to establish and verify a product free from harmful internal defects. When heat-treating is required, heat-treat the entire lot of castings to the specified temper.

Permanently mark the heat or lot number on the web or top of the base of all castings. Furnish mill test reports showing the heat or lot number, chemical composition, tensile strength, elongation, and number of pieces for each casting heat or lot. For aluminum castings, a heat or lot should consist of not more than 1,000 lb. of trimmed castings when produced from batch type furnaces, or 2,000 lb. when produced from a continuous furnace during a period of no more than 8 consecutive hours. Furnish the entire number of acceptable posts cast from each heat or lot except when a portion is required to complete a project.

450.4 to 450.5

4. **Corrosion Protection.** Provide protective coating for all metal railing unless otherwise noted on the plans. Galvanize all portions of steel railing after fabrication in accordance with Item 445, “Galvanizing,” unless otherwise noted on the plans. When painting is specified on the plans, provide the paint system shown on the plans. Apply paint in accordance with Item 446, “Cleaning and Painting Steel.” Repair any damaged galvanizing after erection in accordance with Item 445.

Aluminum railing and galvanized steel railing do not require field painting. Before final acceptance, clean extrusion marks, grease, and dirt from the railing.

5. **Storage.** Store railing materials above the ground on platforms, skids, or other supports, and keep them free from grease, dirt, and contact with dissimilar metals. Avoid scratching, marring, denting, discoloring, or otherwise damaging the railing.
- B. Concrete Railing.** Provide concrete portions of railing in accordance with the requirements of Item 420, “Concrete Structures,” and requirements of this Item. Construct forms so that the railing line and grade can be checked after the concrete has been placed but before initial set. Do not disturb the form alignment during finish floating of the railing tops. Exercise particular care in other construction to avoid disturbing or vibrating the span with the newly placed railing.

Provide precast members conforming to Item 424, “Precast Concrete Structures (Fabrication).”

Concrete railing may be constructed using approved slip-form equipment. Provide sensor control for both line and grade.

- C. **Tests.** The Engineer will sample cast aluminum posts for testing in accordance with Tex-731-I to verify the material requirements of Item 442, “Metal for Structures.” Metal beam rail elements may be sampled in accordance with Tex-713-I. The Engineer may sample bolts and nuts in accordance with Tex-708-I for galvanized coating testing.

450.4. Measurement. This Item will be measured by the foot.

This is a plans quantity measurement Item. The quantity to be paid for is the quantity shown in the proposal except as modified by Article 9.2, “Plans Quantity Measurement.” Additional measurements or calculations will be made if adjustments of quantities are required.

450.5. Payment. The work performed and materials furnished in accordance with this Item and measured as provided under “Measurement”

will be paid for at the unit price bid for “Railing” of the type specified. This price will be full compensation for furnishing, preparing, and placing concrete, expansion joint material, reinforcing steel, structural steel, aluminum, cast steel, pipe, anchor bolts, tie-in anchorage to approach railing or guard fence, anchorage devices for attaching metal beam guard fence or end treatments, and all other materials required in the finished railing; removal and disposal of salvageable materials; and hardware, paint and painting of metal railing, galvanizing, equipment, labor, tools, and incidentals.

ITEM 452 REMOVING RAILING

452.1. Description. Remove railing on 1 or both sides of the structure as directed. Dispose of or stockpile removed railing that is not to be reused on the structure.

452.2. Equipment. Use air-driven equipment or other suitable means to remove railing. Do not use explosives.

452.3. Construction. Remove existing railing to the lines and grades shown on the plans. Do not damage any portion of the structure that is to remain in place. Replace any concrete removed beyond the neat lines or other established lines at the Contractor’s expense.

Incorporate reinforcing steel into the new concrete railing with a minimum 2 in. of clear cover. If existing reinforcing steel in concrete posts cannot be reused as dowels, cut it off at least 1 in. below the finished surface of the concrete. Repair as directed any concrete damaged from making the cut-off.

Refinish the top of the concrete slab where the railing is removed but not replaced to leave a neat surface as specified in the plans and in accordance with Item 420, “Concrete Structures.”

Carefully dismantle all material deemed salvageable for reuse, and place it in neat piles along the right of way at approved loading points. Remove portions of railing not deemed salvable, and dispose of them in accordance with federal, state, and local regulations.

452.4. Measurement. This Item will be measured by the foot in its original position.

452.5 to 453.3

452.5. Payment. The work performed in accordance with this Item and measured as provided under “Measurement” will be paid for at the unit price bid for “Removing Railing” of the element materials specified. This price is full compensation for removing materials; loading, hauling, unloading, and disposing of the material; cutting back old post reinforcing bars and refinishing the top and roadway face of the old curb; and equipment, labor, tools, and incidentals.

Concrete railing to be removed on the side of the structures to be widened will not be paid for under this Item, but will be considered subsidiary to Item 430, “Extending Concrete Structures,” or Item 422, “Reinforced Concrete Slab.”

ITEM 453 TEMPORARY RAILING

453.1. Description. Install and remove temporary railing.

453.2. Materials. Furnish temporary railing using materials and to the details specified on the plans.

Ensure that steel shapes, plates, and deep-beam members are in satisfactory condition for their intended use. Portions of permanent railing to be used later on the permanent structures may be used subject to the requirements of this Item.

For portions of the temporary railing to be used later in the permanent railing, galvanize all portions of steel railing after fabrication in accordance with Item 445, “Galvanizing.” Paint railing only when specified on the plans, and in accordance with Item 446, “Cleaning and Painting Steel.”

Portions of the temporary railing to be furnished by the Department will be shown on the plans. Pick up the railing at the site designated on the plans.

453.3. Construction. Erect temporary railing on the side of the existing structure where widening operations are to begin before the removal of the existing railing, curb, and portion of the slab. Construct the rail and posts in accordance with details shown on the plans.

After completion of the widening on one side of bridges that will be widened on both sides, move the temporary railing to the other side and erect it before the removal of the existing railing and curb.

Maintain temporary railing in an acceptable condition until all work on the structure has been completed or until such time as indicated on the plans.

Upon removal of the railing, deliver salvageable materials furnished by the Department to the storage site designated on the plans.

As directed and in accordance with Item 429, "Concrete Structure Repair," repair any damage, including erection holes, caused to the bridge by the erection of temporary railing,

Repair, refurbish, or replace any temporary railing to be used as permanent railing on the new structure before installing it in its final position. All permanent railing must meet plan requirements.

453.4. Measurement. This Item will be measured by the lump sum.

453.5. Payment. The work performed and materials furnished in accordance with this Item and measured as provided under "Measurement" will be paid for at the unit price bid for "Temporary Railing." This price is full compensation for furnishing materials except those designated on the plans to be furnished by others; preparation, loading, hauling and erection; painting, maintaining, moving, and removing railing; stockpiling rail material on the right of way; and equipment, labor, tools, and incidentals.

ITEM 454

BRIDGE EXPANSION JOINTS

454.1. Description. Furnish and install bridge expansion joints.

454.2. Materials. Provide materials in accordance with the requirements of the following Items:

- Item 442, "Metal for Structures"
- DMS-6140, "Elastomeric Concrete for Bridge Joint Systems"
- DMS-6310, "Joint Sealants and Fillers," Class 7 (Low-Modulus Silicone, Rapid-Curing, Self-Leveling)
- ASTM D-5973, "Standard Specification for Elastomeric Strip Seals with Steel Locking Edge Rails Used in Expansion Joint Sealing."

If required, use primers recommended by the manufacturer of the sealant. Use backer rods compatible with the sealant that do not react or bond together.

454.3. Construction. Place expansion joints to conform to the finished grade of the roadway surface. Set the joint opening at the dimension shown on the plans for 70°F, adjusted for the temperature at the time of installation. For sealed joint openings, place the seal for the full length of

454.3 to 454.3

the joint and, when required, extend it into the parapet wall on the low side or sides of the bridge.

- A. **Sealed Expansion Joint (SEJ).** Choose an approved joint system that conforms to the joint type and the design requirements shown on the plans. Secure each side of the joint by welding it to the adjacent reinforcing steel or other attachments as approved. Remove any connection holding the joint halves together immediately after each joint half is secured in place. Install the neoprene seal as a continuous piece to form a watertight seal.
- B. **Armor Joint.** Place steel armor plates as shown on the plans. Secure each side of the joint by welding it to adjacent reinforcing steel or other attachments as approved. Remove any connection holding joint halves together immediately after each joint half is secured in place.

Seal the joint when specified. Abrasive blast clean the vertical faces of the steel plates where the sealant will be in contact to remove all visible rust, paint, mill scale, and other forms of contamination, leaving a white metal appearance. Clean the concrete in contact with the sealant by an approved method in accordance with the manufacturer's specifications before placing sealant. After cleaning, air-blast the joint to remove all dust. Place sealant in accordance with the manufacturer's specifications and as shown on the plans. Repair damage to paint protection system above the seal when shown on plans for steel armor plates to be painted.

- C. **Header-Type Expansion Joint.** Meet with the manufacturer's representative and the Engineer to discuss the required installation procedures of the materials before beginning the work. Perform the work in accordance with the manufacturer's printed instructions and as discussed in the meeting.
 - 1. **Header.** Create the required void in the concrete surface or asphalt overlay to accept the header material in accordance with the details shown on the plans. Extend the depth of the void in the asphalt overlay to sound concrete. Remove any unsound steel or concrete and repair concrete in accordance with Item 429, "Concrete Structure Repair." Use header material as repair material only when approved. Clean the voided region of all materials that could inhibit the bond between the header material and concrete or steel. Form the joint opening to the required width shown on the plans.

Do not place materials until approved. Place material on a clean, sound, and dry base when the ambient temperature is at least 45°F

and rising or as required by the manufacturer. Do not place material on wet substrate or when raining.

Cure for the duration required by the manufacturer prior to opening to traffic.

Tool or grind the upper corner of the header adjacent to the opening to a 1/4-in. radius.

2. **Sealant.** Clean the joint opening of forming material, existing seal, and other material that will inhibit the bond between the header material and the sealant. Abrasive blast clean surfaces in contact with the sealant. Place an approved backer rod and the sealant as shown on the plans. Place sealant when ambient temperature is rising and is between 55°F and 85°F to provide for adequate joint opening and compression of the sealant during curing.

454.4. Measurement. Sealed expansion joints and armor joints will be measured by the foot. Header-type expansion joints will be measured by the foot or by the cubic foot of header material and foot of sealant. Length measurement will be along the centerline of the joint at the surface of the roadway and up into the parapet. Calculate volume for header-type expansion joints using the length and width shown on the plans and the header depth measured in place.

Sealed expansion joints and armor joints are a plans quantity measurement Item. The quantity to be paid is the quantity shown in the proposal unless modified by Article 9.2, "Plans Quantity Measurement." Additional measurements or calculations will be made if adjustments of quantities are required.

454.5. Payment. The work performed and materials furnished in accordance with this Item and measured as provided under "Measurement" will be paid for at the unit price bid for "Sealed Expansion Joint" of the size (minimum total movement capacity) and designation specified, "Armor Joint," "Armor Joint (With Seal)," and "Header-Type Expansion Joint." Sealing the joint will be subsidiary to these items with the exception of the header-type expansion joint when the header is paid for by volume measurement. This price is full compensation for furnishing and installing the joint systems including steel; and for materials, tools, equipment, labor, and incidentals.

If volume measurement for the header material is specified, the header material will be paid for at the unit price bid for "Header-Type Expansion Joint" and the sealant will be paid for at the unit price bid for "Joint

458.1 to 458.2

Sealant.” This price is full compensation for furnishing and installing the joint systems and for materials, tools, equipment, labor, and incidentals.

ITEM 458

WATERPROOFING MEMBRANES FOR STRUCTURES

458.1. Description. Furnish and place waterproofing membranes on concrete and steel bridge decks of railroad and other types of structures.

458.2. Materials.

A. Materials to be Furnished. Furnish waterproofing materials listed below in accordance with DMS-6300, “Waterproofing”:

- asphalt for mopping above ground,
- asphalt for mopping below ground
- asphaltic primer,
- treated cotton fabric,
- self-adhering polyethylene,
- coal-tar-modified urethane,
- rubberized asphalt with preformed board membrane,
- asphalt plank,
- asphalt mat,
- rubberized asphalt with plastic film,
- asphaltic panels,
- plastic cement, and
- cold asphalt base emulsion.

Furnish butyl rubber membrane and ethylene-propylene-diene terpolymer (EPDM) sheeting in accordance with ASTM D 6134.

Deliver materials requiring sampling and testing to the work site a minimum of 3 weeks before use. When authorized, materials for waterproofing may be tested and approved before delivery to the worksite.

B. Types. Provide the following types of waterproofing as shown on the plans or as directed.

1. **Type 1.** Butyl rubber membrane applied to a surface with a proper adhesive without protective planking and in accordance with the details shown on the plans. Provide a minimum thickness of 1/16 in. unless otherwise shown on the plans.
2. **Type 2.** A single asphaltic primer coat and 1 mopping of asphalt.

3. **Type 3.** A single asphaltic primer coat and 2 moppings of asphalt. When shown on the plans, supplement with 2 layers of treated cotton fabric with a third mopping of asphalt placed over the outer layer of fabric at construction joints of foundation structures.
4. **Type 4.** Self-adhering polyethylene with a rubberized asphalt mastic material.
5. **Type 5.** Single-component, coal-tar-modified urethane coating.
6. **Type 6.** Self-adhering built-up membrane of rubberized asphalt formed on a preformed board with cold-applied asphaltic primer.
7. **Type 10.** Any of Type 1, Type 4, Type 5, or Type 6 waterproofing.
8. **Type RR-1.** Butyl rubber or EPDM membrane with a protective course of asphalt plank or asphalt mat of the specified thickness.

458.3. Construction.

- A. General.** Store waterproofing material in a manner that will prevent damage. Keep material dry at all times, and store in a warm area before using in cold weather and out of direct sunlight in hot weather. Store asphalt planks, asphalt mats, and asphaltic panels in a manner that will prevent warping and breaking.

Provide a wood float finish to concrete decks and other unformed concrete surfaces to be waterproofed. Cure concrete surfaces to be waterproofed for at least 7 days before applying waterproofing.

Ensure that steel or concrete deck surfaces to be waterproofed are clean, dry, smooth, and free of fins, sharp edges, and loose material. Use grinders, if necessary, to remove protrusions that would puncture waterproofing membrane. Ensure surfaces are free of contaminants such as form release agents, wax base curing compounds, oil, and grease. If these contaminants are present, remove them by abrasive blast cleaning. Ensure that there are no depressions or pockets in horizontal surfaces of finished waterproofing.

Unless otherwise required in the plans, fill expansion joints and other grooves with plastic cement conforming to the requirements of DMS-6300, "Waterproofing." Ensure that joints are dry and clean when filled. Overfill slightly to allow for shrinkage in drying.

Sweep, vacuum, or air-blow the area to be waterproofed thoroughly to remove dust, dirt, and loose foreign material. After the deck is clean, maintain it in a clean condition until completion of waterproofing.

458.3 to 458.3

Do not allow vehicular or equipment traffic on the bridge after the deck waterproofing work has started until after the work is complete and an adequate ballast cushion has been placed on the deck. Protect the waterproofing against damage from any source.

Use asphalt for mopping below ground as defined in DMS-6300, "Waterproofing," when asphalt waterproofing is shown as a protection for back of abutments, retaining walls, or footings. Use asphalt for mopping above ground as defined in DMS-6300 for waterproofing on bridge decks.

- B. Type 1.** Do not apply waterproofing in wet weather or when the ambient temperature is below 50°F. Ensure that the rubber membrane is free from punctures, pockets, or folds.

Turn the membrane into drainage holes and castings without break. Take special care to make the waterproofing effective along the sides and ends of members to be waterproofed.

Install the butyl rubber membrane by first applying the adhesive as recommended by the membrane manufacturer. Install the adhesive to the surface to be waterproofed and at necessary splices, in a solid area extending approximately 36 in. back from the edges. Apply the membrane by pressing it firmly and uniformly in place against the previously applied adhesive, avoiding wrinkles and buckles. Make splices, laps, and flashing in accordance with the membrane manufacturer's recommended procedures.

- C. Type 2.** Place the asphalt primer at least 24 hr. before the asphalt mopping. Ensure that the primer is dry before the mopping. Work in the primer to give a uniform coating. Heat the asphalt for mopping in kettles equipped with armored thermometers, but do not heat above 350°F. Stir the asphalt frequently while heating. Apply the mop coating at a rate of at least 4 gal. per 100 sq. ft. of surface. If imperfections appear in the coating, apply additional coatings until the imperfections are corrected.
- D. Type 3.** Place the asphalt primer at least 24 hr. before the asphalt mopping. Ensure that the primer is dry before the mopping. Work in the primer to give a uniform coating. Heat the asphalt for mopping in kettles equipped with armored thermometers, but do not heat above 350°F. Stir the asphalt frequently while heating. Use a minimum coverage rate for each mop coating of 4 gal. per 100 sq. ft. of surface. If imperfections appear in the coating, apply additional coatings until the imperfections are corrected.

At construction joints, mop the surfaces to be waterproofed in sections. Lay a 15-in.-wide strip of cotton fabric on the first mopping while the asphalt is still hot and press into place. Apply subsequent moppings to completely cover and seal the cotton fabric. Do not make the end laps of the cotton fabric less than 12 in. unless otherwise shown on the plans.

- E. Type 4.** Unwrap the roll of waterproofing and press the adhesive surface into contact with the concrete horizontally. Secure the free end and then unroll slowly, using hand pressure to smooth the membrane into place and to help make a tight bond with the concrete. Overlap adjacent strips a minimum of 1 in. over the previously laid strip. Backfilling may be started as soon as the initial horizontal strip has been applied.
- F. Type 5.** Apply waterproofing in 2 coats to produce a minimum cured film thickness of 1/16 in. Unless otherwise shown on the plans, the application may be made using a roller, squeegee, brush, or spray equipment. Apply the second coat within 16 hr. after the initial coat. Follow the manufacturer's instructions with regard to the maximum time allowed between coats and any treatment of the initial coat required if this maximum time is exceeded. The minimum ambient temperature at the time of application of the waterproofing is 40°F. Do not begin backfilling until the second coat of waterproofing has cured sufficiently to prevent damage by the backfilling operation.
- G. Type 6.** Apply the primer at a rate of 1 gal. per 100 sq. ft. of surface or at the rate recommended by the manufacturer if different. Allow to dry to a tacky surface before placing the waterproofing membrane. Apply the primer and waterproofing membrane board panels only when the substrate temperature is above 50°F.

Seal joints by centering 6-in. gusset tape over the joint and pressing firmly into position. Roll in the panels and jointing tape with sufficient pressure to assure maximum adhesion, conformance to substrate, and elimination of air bubbles. Follow the manufacturer's recommendations for installation.

Begin backfilling as soon as the application of the waterproofing is complete. Complete backfilling within 48 hr. after the waterproofing material is applied to a non-horizontal surface.

- H. Type RR-1.** Apply waterproofing to dry surfaces and only when the ambient temperature is above 50°F. Ensure that the butyl rubber or EPDM membrane is free from punctures, pockets, or folds. Turn the membrane into drainage castings without break. Take special care to

458.4 to 458.4

make the waterproofing effective along the sides and ends of girders and at stiffeners, gussets, etc. Fill grooves with plastic cement.

Install the butyl rubber or EPDM membrane by first applying the adhesive as recommended by the membrane manufacturer to ballast retainers, ends of deck, and at necessary splices in a solid area extending from the edges back about 36 in. or as shown on the plans. Apply the membrane and press it firmly and uniformly in place against the previously applied adhesive, avoiding wrinkles and buckles. Make splices, laps, and flashing in accordance with the membrane manufacturer's recommended procedures.

Place the protective cover as soon as practicable after placement of the membrane. Clean the membrane surface of dirt and other foreign material before placing the cover material. Apply a coating of cold asphalt emulsion over the membrane at a minimum rate of 4 gal. per 100 sq. ft. of surface. Place the asphalt plank or mat on the coating of cold asphalt emulsion.

Unless otherwise specified in the plans, provide a minimum thickness of protection of 1 in., consisting of asphalt plank or asphalt mat. Coat the edges and ends of adjacent planks already laid with cold asphalt emulsion as successive planks are laid. Lay the planks tightly against those previously laid so the emulsion will completely fill the joints and be squeezed out the top. Fill any joints not completely full after planks have been laid with emulsion. When 2 layers of planks are used to obtain the required 1-in. cover thickness, offset the vertical joints of the second layer at least 4 in. transversely and 1 ft. longitudinally from the joints in the lower layer.

Apply asphalt mat protection in the same manner except stagger the longitudinal butt joints in a single layer by approximately 2 ft. When more than 1 thickness of asphalt mat is required, follow the same procedure with all vertical joints offset by at least 1 ft. Place a follow-up coating of asphalt emulsion approximately 6 in. wide over all joints of the top layer.

Use asphalt for mopping above ground as defined in DMS-6300, "Waterproofing," where deck waterproofing is carried over the back wall and down the back of the abutment for only several feet to provide a proper flashing for the deck waterproofing.

458.4. Measurement. When waterproofing is shown on the plans to be a pay item, measurement will be by the square yard.

458.5. Payment. Unless otherwise specified on the plans, the work performed, materials furnished, equipment, labor, tools, and incidentals will not be paid for directly but will be considered subsidiary to pertinent Items.

When waterproofing is specified as a pay item, the work performed and materials furnished in accordance with this Item and measured as provided under “Measurement” will be paid for at the unit price bid for “Waterproofing,” of the type specified. This price is full compensation for materials furnished, equipment, labor, tools, and incidentals.

ITEM 459

GABIONS AND GABION MATTRESSES

459.1. Description. Furnish and install gabions and gabion mattresses.

459.2. Materials. This Item uses the following terms:

- Gabion. A wire fabric or mesh container, filled with stone, with a height of 1 ft. or greater.
- Gabion Mattress. A wire fabric or mesh container filled with stone and with a height of 6, 9, or 12 in. Referred to as “revet mattress” in ASTM A 975.

Furnish welded wire gabions and gabion mattresses in accordance with ASTM A 974. Furnish Style 1 or 2 when galvanized wire coating is specified or Style 5 when PVC wire coating is specified.

Furnish twisted wire gabions and gabion mattresses in accordance with ASTM A 975. Furnish Style 1 when galvanized wire coating is specified or Style 3 when PVC wire coating is specified.

Furnish producer or supplier certification that wire baskets, stiffeners, lacing wire, and spiral connectors conform to the applicable ASTM specification.

If alternative wire fasteners are proposed, furnish producer or supplier certification that the fasteners conform to the strength requirements in Table 1 when tested in accordance with the applicable ASTM specification. Submit certification for approval before beginning work.

Table 1
Minimum Panel-to-Panel Connection Strength

Application	Strength (lb/ft)
Gabions, galvanized	1,400
Gabions, PVC-coated	1,200
Gabion mattress, galvanized and PVC-coated	700

Provide filler stone consisting of clean, hard, durable stone that does not contain shale, caliche, or other soft particles. Stone appearing to contain such particles will be tested for soundness. Stone with 5-cycle magnesium sulfate soundness of more than 18% when tested in accordance with Tex-411-A will be rejected. Use stones that are between 4 and 8 in. in their least dimension for gabions and between 3 and 6 in. for gabion mattresses. Prevent contamination when storing and handling stone.

Provide Type 2 filter fabric when required in accordance with DMS-6200, "Filter Fabric."

Provide filter material when required consisting of hard, durable, clean sand or gravel with a maximum particle size of 3/8 in.

459.3. Construction. At the start of construction, the gabion and gabion mattress manufacturer must have a qualified representative available for consultation as needed throughout the gabion and gabion mattress construction.

- A. Foundation Preparation.** Excavate the foundation to the extent shown on the plans or as directed. Remove all loose or otherwise unsuitable materials. Carefully backfill all depressions to grade with suitable materials from adjacent required excavation or another approved source, and compact the backfill to a density at least equal to that of the adjacent foundation. Remove any buried debris protruding from the foundation that will impede the proper installation and final appearance of the gabion or gabion mattress, and carefully backfill and compact voids as specified above. Immediately before gabion placement, have the Engineer inspect the prepared foundation surface.
- B. Filter Placement.** When filter material is required, spread it uniformly on the prepared foundation surface to the slopes, lines, and grades indicated on the plans. Do not place filter material by methods that tend to segregate particle sizes. Repair all damage to the foundation surface that occurs during filter placement before proceeding with the work. Compaction of the filter material is not required, but finish the material to present a reasonably even surface, without mounds or windrows.

- C. Filter Fabric Placement.** When filter fabric is required, place it as shown on the plans. Any defects, rips, holes, flaws, or damage to the material may be cause for rejection. Place the material with the long axis parallel to the centerline of the structure, highway, or dam. Place securing pins in the lapped longitudinal joints, spaced on approximately 10-ft. centers. Keep the fabric material free of tension, stress, folds, wrinkles, or creases. Lap the material at least 3 ft. along the longitudinal joint of material, or lap the joints 1 ft. and sew them. Lap the ends of rolls at joints by at least 3 ft. Repair torn or punctured fabric by placing a layer of fabric over the damaged area, overlapping at least 3 ft. beyond the damaged area in all directions.

Place securing pins through both strips of material at lapped joints at approximately the midpoint of the overlap. Place additional securing pins as necessary to hold filter fabric in position. Store filter fabric out of direct sunlight. After placing filter fabric, cover as soon as possible but within 3 days.

- D. Assembly and Installation.** If PVC wire coating is specified, do not place PVC-coated materials unless the ambient temperature and the temperature of the coated wire are at least 15°F above the brittleness temperature of the PVC.

Assemble empty gabion or gabion mattress units individually, and place them on the approved surface to the lines and grades shown on the plans with the sides, ends, and diaphragms erected to ensure that all creases are in the correct position, the tops of all sides are level, and all sides that are to remain exposed are straight and plumb. Fill the basket units after transporting them to their final position in the work.

Place the front row of gabion or gabion mattress units first, and successively construct units toward the top of the slope or the back of the structure. Place the initial line of basket units on the prepared surface, and partially fill them to provide anchorage against deformation and displacement during subsequent filling operations. Stretch and hold empty basket units as necessary to remove kinks and provide a uniform alignment. Before filling, connect all adjoining empty gabion or gabion mattress units with lacing, wire spiral binders, or approved fasteners along the perimeter of their contact surface to obtain a monolithic structure. If lacing wire is used, provide continuous stitching with alternating single and double loops at intervals of no more than 5 in. Securely fasten all lacing wire terminals.

459.3 to 459.3

Provide connections meeting the joint strength requirements of Article 459.2, "Materials." These requirements apply to all connections including attachment of end panels, diaphragms, and lids.

Join twisted wire baskets through selvage-to-selvage or selvage-to-edge wire connection; do not use mesh-to-mesh or selvage-to-mesh wire connection except where baskets are offset or stacked, in which case join each mesh opening where mesh wire meets selvage or edge wire.

Carefully fill the basket units with stone, using hand placement to avoid damaging wire coating, to ensure as few voids as possible between the stones and to maintain alignment. Machine placement of stone will be allowed if approved by the Engineer. Correct excessive deformation and bulging of the mesh before further filling. To avoid localized deformation, fill the basket units in a row in stages consisting of maximum 12-in. courses; do not at any time fill a cell to a depth exceeding 1 ft. more than its adjoining cell. Do not drop stones into the basket units from a height greater than 36 in.

For gabion units more than 2 ft. high, place 2 uniformly spaced internal connecting wires between each stone layer in all front and side gabion units, connecting the back and the front faces of the compartments. Loop connecting wires or preformed stiffeners around 2 twisted wire-mesh openings or a welded wire joint at each basket face, and securely twist the wire terminals to prevent loosening.

Along all exposed faces, carefully place the outer layer of stone and arrange it by hand to ensure a neat and compact appearance. Overfill the last layer of stone uniformly by 1 to 2 in. for gabions and 1 in. for gabion mattresses to compensate for future settlement in rock while still allowing for the proper closing of the lid and providing an even surface with a uniform appearance. Make final adjustments for compaction and surface tolerance by hand. Stretch lids tight over the stone fill, using an approved lid-closing tool, until the lid meets the perimeter edges of the front and end panels. Do not use crowbars or other single-point leverage bars for lid closing. Close the lid tightly along all edges, ends, and internal-cell diaphragms with spiral binders or lacing wire or with other wire fasteners if approved. Ensure that all projections or wire ends are turned into the baskets. Where shown on the plans or directed or where a complete gabion or gabion mattress unit cannot be installed because of space limitations, cut the basket unit and fold and wire it together to suit site conditions. Fold the mesh back and neatly wire it to an adjacent basket face. Complete the assembling,

installation, filling, lid closing, and lacing of the reshaped gabion or gabion mattress units in accordance with this Section.

459.4. Measurement. Gabions will be measured in place by the cubic yard of stone-filled gabions. Gabion mattresses will be measured in place by the square yard of surface area or by the cubic yard.

459.5. Payment. The work performed and materials furnished in accordance with this Item and measured as provided under “Measurement” will be paid for at the unit price bid for “Gabions” of the basket-wire coating specified, and per square yard of “Gabion Mattresses” of the thickness and basket-wire coating specified or per cubic yard of “Gabion Mattresses” of the basket-wire coating specified.

The price bid is full compensation for wire baskets, stone fill, lacing and fasteners, filter fabric, filter material, excavation, grading and backfill, materials, tools, equipment, labor, and incidentals. Filter fabric and filter material, if used, will not be paid for directly but will be considered subsidiary to this Item.

**ITEM 460
CORRUGATED METAL PIPE**

460.1. Description. Furnish and install corrugated metal pipes, materials for constructing corrugated metal pipe culverts, or corrugated metal storm drain mains, laterals, stubs, and inlet leads.

460.2. Materials.

A. Fabrication. Furnish corrugated metal pipe in accordance with Table 1.

**Table 1
Specifications for Corrugated Metal Pipe**

Pipe Type	AASHTO Specification
Galvanized steel and aluminized steel	M 36
Pre-coated galvanized steel	M 245
Aluminum	M 196

The pipe type and corresponding AASHTO designations are shown in Table 2.

Table 2
Corrugated Metal Pipe Types

Pipe Type	AASHTO Classification
Circular	Type I
Circular, smooth-lined	Type IA
Circular, spiral rib	Type IR
Arch	Type II
Arch, smooth-lined	Type IIA
Arch, spiral rib	Type IIR

Provide corrugated metal pipe of all types with annular corrugations, helical corrugations, or spiral ribs (corrugations) projecting outward. Provide pipe with helical end corrugations only when necessary to join new pipe to existing pipe with helical end corrugations.

For pre-coated galvanized steel pipe, provide a minimum polymer coating thickness of 10 mils on each side. Galvanized metal sheets and coils used for galvanized corrugated metal pipe may be sampled and tested in accordance with Tex-708-I.

Repair damaged galvanized coating in accordance with Item 445.3.D, "Repairs." Repair damaged aluminized or polymer coating in accordance with AASHTO M 36 and M 245 respectively.

- B. Protective Coating.** When required, furnish bituminous coating that meets AASHTO M 190 and that tightly adheres to the metal, does not chip off in handling, and protects the pipe from deterioration as evidenced by samples prepared from the coating material successfully meeting the Shock Test and Flow Test in accordance with Tex-522-C.

Uniformly coat the pipe inside and out to a minimum thickness of 0.05 in. measured on the crests of the corrugations. When smooth lining is specified, coat the pipe with additional material applied to the full inner circumference to form a smooth inside lining with a minimum thickness of 1/8 in. above the crest of the corrugations.

- C. Design.** For full-circle pipe, the diameter, permissible corrugations, and required gauges will be shown. For pipe arch, the design size and permissible corrugations will be shown. For smooth lined pipe, the required gauges of the shell and the liner will also be shown. For steel pipe arch, furnish the shape and minimum gauge in accordance with Tables 3, 4, 5, or 6 for the specified design size and corrugation. For aluminum pipe arch, use Table 7 or 8. Where reference is made to gauge of metal, the reference is to U.S. Standard Gauge for uncoated sheets.

Measure dimensions from the inside crests of the corrugations. A tolerance of ± 1 in. or 2% of the equivalent circular diameter, whichever is greater, is allowed for span and rise.

Table 3
Steel Pipe Arch
2-2/3 by 1/2-in. Corrugations

Design Size	Span (in.)	Rise (in.)	Min. Cover (in.)	Min. Gauge Required	Coated Thickness (in.)	Equivalent Diameter Full-Circle Pipe (in.)
1	17	13	12	16	0.064	15
2	21	15	12	16	0.064	18
2A	23	19	12	16	0.064	21
3	28	20	12	16	0.064	24
4	35	24	12	16	0.064	30
5	42	29	12	14	0.079	36
6	49	33	12	14	0.079	42
7	57	38	12	12	0.109	48
8	64	43	12	12	0.109	54
9	71	47	12	10	0.138	60

Table 4
Steel Pipe Arch
3 by 1-in. Corrugations

Design Size	Span (in.)	Rise (in.)	Min. Cover (in.)	Min. Gauge Required	Coated Thickness (in.)	Equivalent Diameter Full-Circle Pipe (in.)
7	53	41	12	14	0.079	48
8	60	46	12	14	0.079	54
9	66	51	12	14	0.079	60
10	73	55	12	14	0.079	66
11	81	59	12	14	0.079	72
12	87	63	12	14	0.079	78
13	95	67	12	12	0.109	84
14	103	71	18	12	0.109	90
15	112	75	18	12	0.109	96
16	117	79	18	12	0.109	102
17	128	83	24	10	0.138	108
18	137	87	24	10	0.138	114
19	142	91	24	10	0.138	120

Table 5
Steel Pipe Arch
5 by 1-in. Corrugations

Design Size	Span (in.)	Rise (in.)	Min. Cover (in.)	Min. Gauge Required	Coated Thickness (in.)	Equivalent Diameter Full-Circle Pipe (in.)
11	81	59	12	12	0.109	72
12	87	63	12	12	0.109	78
13	95	67	12	12	0.109	84
14	103	71	18	12	0.109	90
15	112	75	18	12	0.109	96
16	117	79	18	12	0.109	102
17	128	83	24	10	0.138	108
18	137	87	24	10	0.138	114
19	142	91	24	10	0.138	120

Table 6
Steel Pipe Arch, Spiral Rib
7-1/2 by 3/4 by 3/4-in. Corrugations

Design Size	Span (in.)	Rise (in.)	Min. Cover (in.)	Min. Gauge Required	Coated Thickness (in.)	Equivalent Diameter Full-Circle Pipe (in.)
2	20	16	12	16	0.064	18
2A	23	19	12	16	0.064	21
3	27	21	12	16	0.064	24
4	33	26	12	16	0.064	30
5	40	31	12	14	0.064	36
6	46	36	12	12	0.064	42
7	53	41	12	12	0.079	48
8	60	46	12	12	0.079	54
9	66	51	15	12	0.079	60

Table 7
Aluminum Pipe Arch
2-2/3-in. by 1/2-in. Corrugations

Design Size	Span (in.)	Rise (in.)	Min. Cover (in.)	Min. Gauge Required	Coated Thickness (in.)	Equivalent Diameter Full-Circle Pipe (in.)
1	17	13	12	16	0.060	15
2	21	15	12	16	0.060	18
2A	23	19	12	16	0.060	21
3	28	20	12	14	0.075	24
4	35	24	12	14	0.075	30
5	42	29	18	12	0.105	36
6	49	33	18	12	0.105	42
7	57	38	18	10	0.135	48
8	64	43	18	10	0.135	54
9	71	47	18	8	0.164	60

Table 8
Aluminum Pipe Arch, Spiral Rib
7-1/2 by 3/4 by 3/4-in. Corrugations

Design Size	Span (in.)	Rise (in.)	Min. Cover (in.)	Min. Gauge Required	Coated Thickness (in.)	Equivalent Diameter Full-Circle Pipe (in.)
2	20	16	12	16	0.064	18
2A	23	19	12	16	0.064	21
3	27	21	15	16	0.064	24
4	33	26	18	16	0.064	30
5	40	31	18	14	0.075	36
6	46	36	18	12	0.105	42
7	53	41	21	12	0.105	48
8	60	46	18	10	0.135	54
9	66	51	21	10	0.135	60

- D. Coupling Bands.** Furnish coupling bands and other hardware for galvanized or aluminized steel pipe in accordance with AASHTO M 36 for steel pipe and AASHTO M 196 for aluminum pipe. Do not use coupling bands that are more than 3 nominal sheet thicknesses lighter than the thickness of the pipe to be connected or that are lighter than

460.3 to 460.3

0.052 in. for steel or 0.048 in. for aluminum. Provide coupling bands made of the same base metal and coating as the pipe.

460.3. Construction.

A. Designation of Type. The types of pipes will be indicated on the plans by the following descriptions:

- Pipe type: Corrugated metal pipe (CMP), corrugated metal pipe arch (CMP ARCH), spiral rib corrugated metal pipe (SRCMP), or spiral rib corrugated metal pipe arch (SRCMP ARCH);
- Type of material: Galvanized steel, aluminum-coated (Type 2), or aluminum;
- Pipe coating: Bituminous coated or polymer coated;
- Special requirements: Paved invert or smooth lining; and
- Pipe size: Diameter or design number.

When pipe is designated as “Corrugated Metal Pipe” without a type of material or pipe coating designation, furnish any of the material types specified above.

B. Excavation, Shaping, Bedding, and Backfill. Excavate, shape, bed, and backfill in accordance with Item 400, “Excavation and Backfill for Structures,” except where jacking, boring, or tunneling methods are shown on the plans or are permitted. Jack, bore, or tunnel in accordance with Item 476, “Jacking, Boring, or Tunneling Pipe or Box.”

Provide uniform backfill material and uniformly compacted density throughout the length of the structure so that equal pressure is provided. Unless otherwise shown on the plans or permitted in writing, no heavy earth-moving equipment is allowed over the structure until a minimum of 4 ft. of compacted fill (permanent or temporary) has been placed over the top of the structure. Before adding each new layer of loose backfill material, inspect the inside periphery of the structure for local or unequal deformation caused by improper construction methods. Continue inspections until a minimum of 24 in. of cover is obtained. Evidence of such deformation will be reason for corrective measures as directed. Remove and replace pipe damaged by the Contractor at no additional cost to the Department.

C. Laying Pipe. Unless otherwise authorized, lay pipes on the bedding from the outlet end and join the separate sections firmly together with outside laps of annular joints pointing upstream and longitudinal laps on the sides. If any metal in joints is not protected by galvanizing or aluminizing, coat it with a suitable asphalt paint. Lower sections of pipe into the trench without damaging the pipe or disturbing the bedding and

the sides of the trench. Remove and re-lay, without extra compensation, pipe that is not in alignment or that shows excessive settlement after laying.

Lay multiple installations of corrugated metal pipe and pipe arches with the centerlines of individual barrels parallel. Unless otherwise indicated on the plans, maintain the clear distances between outer surfaces of adjacent pipes given in Table 9.

Table 9
Required Pipe Clear Distances

Diameter Full-Circle Pipe (in.)	Pipe Arch Design Size	Clear Distance Between Pipes. (Full-Circle Pipe and Pipe Arch)
18	2	1 ft. 2 in.
21	2A	1 ft 3 in
24	3	1 ft. 5 in.
30	4	1 ft. 8 in.
36	5	1 ft. 11 in.
42	6	2 ft. 2 in.
48	7	2 ft. 5 in.
54	8	2 ft. 10 in.
60 to 84	9	3 ft. 2 in.
90 to 120	10 and over	3 ft. 5 in.

- D. Jointing.** Provide field joints that maintain pipe alignment during construction and prevent infiltration of side material during the life of the installation. Unless otherwise shown on the plans, provide one of the following jointing systems:
- 1. Coupling Bands.** Use coupling bands with annular corrugations only with pipe with annular corrugations or with helical pipe or spiral rib pipe in which the ends have been rerolled to form annular corrugations. Provide bands with corrugations that have the same dimensions as the corrugations in the pipe end or that are designed to engage the first or second corrugation from the end of each pipe. The band may also include a U-shaped channel to accommodate upturned flanges on the pipe.

When helical end corrugations are allowed, field-join pipe with helically corrugated bands or bands with projections (dimples).

460.3 to 460.3

Coupling bands with projections may be used with pipe that has annular or helical end corrugations or spiral ribs. Provide bands formed with the projections in annular rows with 1 projection for each corrugation of helical pipe or spiral rib pipe. Provide 2 annular rows for bands 10-1/2 in. or 12 in. wide and 4 annular rows of projections for bands 16-1/2 in. or 22 in. wide.

Use a coupling band width that conforms to Table 10. Connect the bands using suitable galvanized devices in accordance with AASHTO M 36. Lap coupling bands equally on each of the pipes to form a tightly closed joint after installation. For corrugations not shown in Table 10, provide at least the minimum coupling band width recommended by the manufacturer.

**Table 10
Coupling Band Width Requirements**

Nominal Corrugation Size ¹ (in.)	Nominal Pipe Inside Diameter ² (in.)	Minimum Coupling Band Width (in.)		
		Annular Corrugated Bands	Helically Corrugated Bands	Bands with Projections
2-2/3 by 1/2	12 to 36	7	12	10-1/2
	42 to 72	10-1/2	12	10-1/2
	78 to 84 ³	10-1/2	12	16-1/4
3 by 1	36 to 72	12	14	10-1/2
	78 to 120	12	14	16-1/4
5 by 1	36 to 72	20	22	12
	78 to 120	20	22	22
7-1/2 by 3/4 by 3/4	18 to 60	10-1/2	12	10-1/2
	66 to 102	10-1/2	12	16-1/4

1. For helically corrugated pipe or spiral rib pipe with rerolled ends, the nominal size refers to the dimensions of the end corrugations in the pipe.

2. Equivalent circular diameter for Type II pipe.

3. Diameter through 120 in. for annular corrugated bands used on rerolled ends of helically corrugated pipe or spiral rib pipe.

The minimum diameter of bolts for coupling bands is 3/8 in. for pipe diameters 18 in. and less and 1/2 in. for pipe diameters 21 in. and greater. For bands 12 in. wide or less, provide at least 2 bolts. For bands wider than 12 in., provide at least 3 bolts.

Provide galvanized hardware in accordance with Item 445, "Galvanizing."

- Bell and Spigot.** Attach the bell to one end of the corrugated metal pipe at the manufacturing plant before shipment. Provide a bell

with a minimum 6-in. stab depth. Install the gasket on the spigot end and apply lubricant in accordance with the manufacturer's recommendations. Provide gaskets that meet ASTM F 477 with Type A Shore durometer hardness of 45 ± 5 . Do not use thermoplastic elastomer as the basic polymer. During laying of the pipe, push the spigot end of the pipe into the bell end of the previously laid pipe.

3. **Pipe Connections and Stub Ends.** Make connections of pipe to existing pipe or appurtenances as shown on the plans or as directed. Mortar or concrete the bottom of the existing structure, if necessary, to eliminate any drainage pockets created by the new connection.

Insulate portions of aluminum pipe that are to be in contact with metal other than aluminum by a coating of bituminous material meeting the requirements of Section 460.2.B, "Protective Coating." Extend the coating a minimum of 1 ft. beyond the area of contact.

When connecting pipe into existing structures that will remain in service, restore any damage that results from making the connection. Seal stub ends for connections to future work not shown on the plans by installing watertight plugs into the free end of the pipe.

460.4. Measurement. This Item will be measured by the foot. Pipe will be measured between the ends of the barrel along the flow line, not including safety end treatments. Safety end treatments will be measured in accordance with Item 467, "Safety End Treatment." Pipe that is required to be jacked, bored, or tunneled will be measured in accordance with Item 476, "Jacking, Boring, or Tunneling Pipe or Box." Where spurs, branches, or connections to existing pipe lines are involved, measurement of the spur or new connecting pipe will be made from the intersection of the flow line with the outside surface of the pipe into which it connects. Where inlets, headwalls, catch basins, manholes, junction chambers, or other structures are included in lines of pipe, the length of pipe tying into the structure wall will be included for measurement but no other portion of the structure length or width will be included.

For multiple pipes, the measured length will be the sum of the lengths of the barrels.

This is a plans quantity measurement Item. The quantity to be paid is the quantity shown in the proposal, unless modified by Article 9.2, "Plans

460.5 to 461.2

Quantity Measurement.” Additional measurements or calculations will be made if adjustments of quantities are required.

460.5. Payment. The work performed and materials furnished in accordance with this Item and measured as provided under “Measurement” will be paid for at the unit price bid for “Corrugated Metal Pipe,” “Corrugated Metal Pipe Arch,” “Spiral Rib Corrugated Metal Pipe,” or “Spiral Rib Corrugated Metal Pipe Arch” of the type, size, and coating specified. This price is full compensation for furnishing, hauling, placing, and joining of pipes; jointing materials; all connections to new or existing structures; breaking back, removing, and disposing of portions of the existing structure; replacing portions of the existing structure; cutting pipe ends on skew or slope; and equipment, labor, tools, and incidentals.

Protection methods for excavations greater than 5 ft. deep will be measured and paid for as required under Item 402, “Trench Excavation Protection,” or Item 403, “Temporary Special Shoring.” Excavation, shaping, bedding, and backfill will be paid for in accordance with Item 400, “Excavation and Backfill for Structures.” When jacking, boring, or tunneling is used at the Contractor’s option, payment will be made under this Item. When jacking, boring, or tunneling is required, payment will be made under Item 476, “Jacking, Boring, or Tunneling Pipe or Box.”

ITEM 461

STRUCTURAL PLATE STRUCTURES

461.1. Description. Furnish and install structural plate pipes, pipe arches, arches, underpasses, box culverts, and special shapes.

461.2. Materials.

A. General. Furnish materials in accordance with the following:

- Item 420, “Concrete Structures”
- Item 421, “Hydraulic Cement Concrete”
- Item 440, “Reinforcing Steel”
- Item 442, “Metal for Structures”
- Item 445, “Galvanizing”
- Item 447, “Structural Bolting.”

Provide galvanized steel plates conforming to AASHTO M 167.

Provide aluminum plates conforming to AASHTO M 219.

Use Class C concrete for footings unless otherwise shown on the plans.

- B. Fabrication.** Use structural units of corrugated galvanized metal for steel plates. Furnish single plates in standard sizes to permit structure length increments of 2 ft. Provide plates with an approximately 2-in. lip beyond each end crest. Design and construct footings for arches to accommodate this additional length. When required, fabricate galvanized steel inverts, toe walls, footings, and closure plates in accordance with the requirements for the galvanized steel structural plate structure.

Use structural units of corrugated aluminum alloy for aluminum plates. For aluminum alloy structures, furnish cut plates on structure ends to permit structure length increments of 1 ft. Provide plates with an approximately 2-in. lip beyond each end crest. Design and construct footings for arches to accommodate this additional length. When required, fabricate aluminum alloy inverts, toe walls, footings, and closure plates in accordance with the requirements for the aluminum structural plate structure.

Form plates to provide bolted lap joints. Punch bolt holes so that all plates having like dimensions, curvature, and number of bolts per foot of seam will be interchangeable. Curve each plate to the proper radius to provide cross-sectional dimensions of the finished structure as shown on the plans. Stagger joints so that not more than 3 plates are joined at any one point.

Unless otherwise specified, provide bolt holes along the edges of the plates that will form longitudinal seams in the finished structure as follows:

- For galvanized steel structures, stagger holes in rows 2 in. apart, with one row in the valley and one on the crest of the corrugations and at least 4 bolts per foot.
- For aluminum alloy structures, provide holes in rows 1-3/4 in. apart with two 2 bolts in each valley and on each crest and at least 16 bolts per 3 ft.

Provide bolt holes at a maximum spacing of 12 in. along the edges of the plates that will form circumferential seams in the finished structure. Ensure a minimum distance from center of hole to edge of plate of not less than 1-3/4 times the diameter of the bolt. Provide bolt holes in the longitudinal seams with a hole diameter that does not exceed the diameter of the bolt by more than 1/8 in. Finish burned edges so that they are galvanized and free from oxide and burrs and present a satisfactory appearance. Place legible identification marks on each plate to designate its proper position in the finished structure.

461.3 to 461.3

Furnish an itemized statement of the number and size of plates in each shipment, and furnish erection drawings showing the position of the plates in the structure. Furnish copies of mill test reports for the base metal. When directed, provide samples of the plates in accordance with Tex-708-I, "Sampling Galvanized Metal Products for Coating Weight."

Provide metal headwalls that comply with the details shown on the plans.

- C. **Design.** The gauge or minimum thickness and permissible corrugations of metal plates to be furnished for each structure will be shown on the plans.

461.3. Construction.

- A. **Designation of Type.** The type of structure will be indicated on the plans by the following descriptions:
- Structure type: structural plate pipe, structural plate pipe arch, structural plate arch, structural plate underpass, or structural plate box culvert.
 - Type of material: galvanized steel or aluminum.
 - Structure size: diameter or horizontal and vertical dimensions.
 - When the type of material is not specified: either galvanized steel or aluminum.
- B. **Foundations.** Construct substructure for structural plate arches as shown on the plans. Form and finish footings to established true lines and grades. Set anchors or box culvert slots to true line and grade when placing concrete for each substructure unit. Place substructure units in accordance with Item 420, "Concrete Structures," and Item 440, "Reinforcing Steel."

Place footings entirely on hard materials such as rock or shale or on firm soil or compacted soil cushion. When only a portion of the founding area is rock, undercut and replace it with a minimum 12-in.-thick compacted soil cushion. When a thin layer of soil is partially covering rock within the bearing area, remove the soil and place the footings directly on rock in accordance with details shown on the plans.

- C. **Erection.** If any steel in joints is not protected by galvanizing, coat it with suitable asphalt paint. Handle pipes and plates carefully to avoid damage to any protective coating.

For anchoring plates to headwalls or other concrete end treatment, provide hot-dip galvanized anchor bolts with a minimum 3/4-in. diameter and 6-in. length spaced at maximum 19-in. centers. Place

plates for arch structures after the substructure has cured a minimum of 3 days.

When all plates are in position, insert all bolts not already in place, and tighten all nuts progressively and uniformly, beginning at one end of the structure. Tighten all nuts a second time to a torque between 150 and 300 ft.-lb. for steel bolts and between 100 and 150 ft.-lb. for aluminum bolts. When using an impact wrench, check at least 20% of the bolts with a torque wrench. Replace all service bolts used in drawing the plates together with standard bolts.

During erection, the tolerance for span and rise is 2% of design measurements or 5 in., whichever is less.

D. Workmanship. Repair minor damage to galvanized coating in accordance with Item 445.3.D, "Repairs." All other structural plates on which the galvanized coating has been damaged or that show defective workmanship will be rejected. This requirement applies not only to the individual plates but also to the shipment as a whole. The presence of any of the following defects will be cause for rejection:

- uneven laps;
- elliptical shape (unless specified);
- variation from a straight line;
- ragged edges;
- loose bolts;
- uneven bolt lines or spacing;
- illegible brand;
- bruised, scaled, or broken galvanized coating; or
- dents or bends in the metal.

E. Excavation and Backfill. Excavate and backfill or construct the embankment around and over the structural plate structure in accordance with Item 400, "Excavation and Backfill for Structures," except as modified in this Section. Furnish acceptable devices for monitoring the horizontal and vertical shape of the structure. During backfilling operations, the tolerance for span and rise is 2% of design measurements or 5 in., whichever is less.

For arches (except pipe arches), if the headwalls are built after backfilling the arch, place the first material midway between the ends of the arch, forming as narrow a ramp as possible until the top of the arch is reached. Construct the ramp evenly from both sides, and thoroughly compact the backfill as it is placed. After constructing the two ramps to the top of the arch, deposit the remainder of the backfill from the top of the arch both ways from the center to the ends and as

461.4 to 461.4

evenly as possible on both sides of the arch. If the headwalls are built before backfilling the arch, place the fill material first adjacent to one headwall until the top of the arch has been reached and then from the top of the arch toward the other headwall. Deposit the material evenly on both sides of the arch.

For multiple structures, perform the same backfill phases for all structures more or less simultaneously. Do not drop backfill from such a height or concentrate it in such an amount prior to distribution over the top arch that it will damage the flexible structure. Compact this backfill with hand-operated tamps or other acceptable equipment.

Until a minimum of 2 ft. of cover has been compacted over the structure, use only hand-operated, mechanical tamping equipment within vertical planes 2 ft. beyond the horizontal limits of the structure. Ensure that all large construction equipment is kept a minimum of 3 ft. from the center of the span to prevent local deformations of the plates due to concentrated loads. Unless otherwise shown on the plans or permitted in writing, do not use heavy earth-moving equipment over the structure until a minimum of 4 ft. of permanent or temporary compacted fill has been placed over the structure. Check with the structure manufacturer prior to crossing the structure with any construction equipment with a 75,000-lb. or greater single-axle load. Additional cover beyond 4 ft. may be required to accommodate these vehicles. Remove and replace damaged plates or structures at no expense to the Department.

Before adding each new layer of loose backfill material, inspect the inside periphery of the structure for local or unequal deformation caused by improper construction methods. Continue inspections until a minimum of 24 in. of cover is obtained. Evidence of such deformation will be reason for corrective measures as directed.

461.4. Measurement. Structural plate pipes, pipe arches, arches, underpasses, and box culverts will be measured by the foot. Measurement will be made between the ends of the barrel along the flow line, not including safety end treatments. Safety end treatments will be measured in accordance with Item 467, "Safety End Treatment."

For multiple structures, the measured length will be the sum of the lengths of the barrels.

This is a plans quantity measurement Item. The quantity to be paid is the quantity shown in the proposal unless modified by Article 9.2, "Plans

Quantity Measurement.” Additional measurements or calculations will be made if adjustments of quantities are required.

461.5. Payment. The work performed and materials furnished in accordance with this Item and measured as provided under “Measurement” will be paid for at the price bid for “Structural Plate Pipes,” “Structural Plate Pipe Arches,” “Structural Plate Underpasses,” and “Structural Plate Box Culverts” of the size, gauge or minimum thickness, and material specified. This price is full compensation for furnishing, transporting, and erecting the structural plate structures; bolts, nuts, washers, anchor bolts, and anchor channels or angles; aluminum alloy inverts, toe walls, footings, closure plates, and stiffeners; and equipment, labor, tools, and incidentals.

Inverts, toe walls, footings, closure plates, elbows, skewed sections, and stiffeners will not be paid for directly but are subsidiary to this Item.

Protection methods for excavations greater than 5 ft. in depth will be measured and paid for as required under Item 402, “Trench Excavation Protection,” or Item 403, “Temporary Special Shoring.” Excavation, shaping, bedding, and backfill will be paid for in accordance with Item 400, “Excavation and Backfill for Structures.”

ITEM 462

CONCRETE BOX CULVERTS AND STORM DRAINS

462.1. Description. Furnish, construct, and install concrete box culverts and storm drains.

462.2. Materials.

A. General. Furnish materials in accordance with the following:

- Item 420, “Concrete Structures”
- Item 421, “Hydraulic Cement Concrete”
- Item 440, “Reinforcing Steel”
- Item 464, “Reinforced Concrete Pipe.”

Provide cast-in-place or precast, formed or machine-made, box culverts and storm drains. For culverts with overlay or a 1- to 2-course surface treatment or if the top slab is the final riding surface, use Class S concrete for top slabs of cast-in-place concrete culverts unless otherwise shown on the plans. Use Class C concrete for the rest of the culvert and for all other cast-in-place boxes. Culverts with fill do not require Class S concrete.

462.2 to 462.2

Furnish concrete for machine-made precast boxes in accordance with ASTM C 1433.

When sulfate-resistant concrete is required, do not use Class C fly ash.

B. Fabrication.

1. **Cast-in-Place.** Meet Item 420, “Concrete Structures.”
2. **Formed Precast.** Meet Item 424, “Precast Concrete Structures (Fabrication).”
3. **Machine-Made Precast.** Furnish machine-made precast boxes in accordance with ASTM C 1433. Ensure that concrete is placed uniformly in the forms. Compact by mechanical devices to ensure dense concrete. Mix concrete in a central batch plant or other approved batching facility from which the quality and uniformity of the concrete can be ensured. Do not use transit-mixed concrete.

C. Testing.

1. **Cast-in-Place.** Provide test specimens that meet Item 421, “Hydraulic Cement Concrete.”
2. **Formed Precast.** Produce test specimens in accordance with Tex-704-I.
3. **Machine-Made Precast.** Make test specimens in test cylinders at the same time and in the same manner as the box sections they represent. Make a minimum of 4 test cylinders for each day’s production run and each mix design. Cure test cylinders in the same manner and for the same times as the boxes they represent. Test the specimens in accordance with Tex-704-I.
4. **Testing Equipment.** The producer must furnish all equipment required for testing concrete for boxes produced in a precasting plant.

D. Lifting Holes. For precast boxes, provide no more than 4 lifting holes in each section. Lifting holes may be cast, cut into fresh concrete after form removal, or drilled. Provide lifting holes of sufficient size for adequate lifting devices based on the size and weight of the box section. Do not use lifting holes larger than 3 in. in diameter. Do not cut more than 1 longitudinal wire or 2 circumferential wires per layer of reinforcing steel when locating lift holes. Repair spalled areas around lifting holes.

E. Marking. Mark precast boxes with the following:

- name or trademark of the producer;
- date of manufacture;

- box size;
- minimum and maximum fill heights; and
- match marks for proper installation, when required, under Section 462.2.F, “Tolerances.”

For boxes without lifting holes, mark 1 end of each box section on the inside and outside walls to indicate the top or bottom as it will be installed.

Indent markings into the box section or paint them on each box with waterproof paint.

- F. Tolerances.** Ensure that precast sections of either type meet the following requirements:
- The inside vertical and horizontal dimensions do not vary from plan requirements by more than 1/2 in. or 1%, whichever is greater.
 - The horizontal or vertical plane at each end of the box section does not vary from perpendicular by more than 1/2 in. or 1%, whichever is greater, measured on the inside faces of the section.
 - The sides of a section at each end do not vary from being perpendicular to the top and bottom by more than 1/2 in. or 1%, whichever is greater, when measured diagonally between opposite interior corners.

Ensure that wall and slab thicknesses are not less than shown on the plans except for occasional deficiencies not greater than 1/4 in. or 5%, whichever is greater. If proper jointing is not affected, thicknesses in excess of plan requirements are acceptable.

Deviations from the above tolerances will be acceptable if the sections can be fitted at the plant or job site and the joint opening at any point does not exceed 1 in. Use match marks for proper installation on sections that have been accepted in this manner.

- G. Defects and Repair.** Fine cracks on the surface of the member that do not extend to the plane of the nearest reinforcement are acceptable unless the cracks are numerous and extensive. Repair cracks that extend into the plane of the reinforcing steel in an approved manner. Excessive damage, honeycomb, or cracking will be subject to structural review. The Engineer may accept boxes with repairs that are sound, properly finished, and cured in conformance with pertinent specifications. When fine cracks on the surface indicate poor curing practices, discontinue further production of precast sections until corrections are made and proper curing is provided.

462.3 to 462.3

- H. Storage and Shipment.** Store precast sections on a level surface. Do not place any load on the sections until design strength is reached and curing is complete. Shipment of sections is permissible when the design strength and curing requirements have been met.

462.3. Construction.

- A. Excavation, Shaping, Bedding, and Backfill.** Excavate, shape, bed, and backfill in accordance with Item 400, "Excavation and Backfill for Structures," except where jacking, boring, or tunneling methods are shown on the plans or are permitted. Jack, bore, or tunnel in accordance with Item 476, "Jacking, Boring, or Tunneling Pipe or Box." For all box structures where joints consist of materials other than mortar, immediate backfilling is permitted. Take precautions in placing and compacting the backfill to avoid any movement of the boxes or damage to the joints. Remove and replace boxes damaged by the Contractor at no expense to the Department.
- B. Placement of Boxes.** When precast boxes are used to form multiple barrel structures, place the box sections in conformance with the plans or as directed. Place material to be used between barrels as shown on the plans or as directed. Unless otherwise authorized, start the laying of boxes on the bedding at the outlet end and proceed toward the inlet end with the abutting sections properly matched. Fit, match, and lay the boxes to form a smooth, uniform conduit true to the established lines and grades. For trench installations, lower the box sections into the trench without damaging the box or disturbing the bedding and the sides of the trench. Carefully clean the ends of the box before it is placed. Prevent the earth or bedding material from entering the box as it is laid. Remove and re-lay, without extra compensation, boxes that are not in alignment or that show excessive settlement after laying. Form and place cast-in-place boxes in accordance with Item 420, "Concrete Structures."
- C. Jointing.** Unless otherwise shown on the plans, use any of the jointing materials in accordance with the jointing requirements specified in Item 464, "Reinforced Concrete Pipe."
- D. Connections and Stub Ends.** Make connections of boxes to existing boxes, pipes, storm drains, or storm drain appurtenances as shown on the plans. Mortar or concrete the bottom of existing structures if necessary to eliminate any drainage pockets created by the connections. Connect boxes to any required headwalls, wingwalls, safety end treatments or riprap, or other structures as shown on the plans or as

directed. Repair any damage to the existing structure resulting from making the connections. Finish stub ends for connections to future work not shown on the plans by installing watertight plugs into the free end of the box.

For precast boxes, fill lifting holes with mortar or concrete and cure. Precast concrete or mortar plugs may be used.

462.4. Measurement. This Item will be measured by the foot. Measurement will be made between the ends of the culvert or storm drain along the flow line, not including safety end treatments. Safety end treatments will be measured in accordance with Item 467, "Safety End Treatment." Measurement of spurs, branches, or new connection box section will be made from the intersection of the flow line with the outside surface of the structure into which it connects. Where inlets, headwalls, wingwalls, catch basins, manholes, junction chambers, or other structures are included in lines of culverts or storm drains, the length of box section tying into the structure wall will be included for measurement, but no other portion of the structure length or width will be included.

The measured length of multiple barrel structures will be the sum of the lengths of the barrels.

This is a plans quantity measurement Item. The quantity to be paid is the quantity shown in the proposal unless modified by Article 9.2, "Plans Quantity Measurement." Additional measurements or calculations will be made if adjustments of quantities are required.

462.5. Payment. The work performed and materials furnished in accordance with this Item and measured as provided under "Measurement" will be paid for at the unit price bid for "Concrete Box Culvert" of the size specified. This price is full compensation for constructing, furnishing, and transporting sections; preparation and shaping of the bed; backfill material between box sections; jointing of sections; jointing material; cutting of sections on skew or slope; connections to new or existing structures; breaking back, removing and disposing of portions of the existing structure and replacing portions of the existing structure as required to make connections; concrete and reinforcing steel; and equipment, labor, materials, tools, and incidentals.

Protection methods for excavations greater than 5 ft. deep will be measured and paid for as required under Item 402, "Trench Excavation Protection," or Item 403, "Temporary Special Shoring." Excavation, shaping, bedding, and backfill will be paid for in accordance with Item 400, "Excavation and Backfill for Structures." When jacking, boring, or tunneling is used at the

464.1 to 464.2

Contractor's option, payment will be made under this Item. When jacking, boring, or tunneling is required, payment will be made under Item 476, "Jacking, Boring, or Tunneling Pipe or Box."

ITEM 464 REINFORCED CONCRETE PIPE

464.1. Description. Furnish and install reinforced concrete pipe, materials for precast concrete pipe culverts, or precast concrete storm drain mains, laterals, stubs, and inlet leads.

464.2. Materials.

- A. Fabrication.** Provide precast reinforced concrete pipe that conforms to the design shown on the plans and to the following:
- ASTM C 76 or ASTM C 655 unless otherwise shown on the plans for circular pipe, or
 - ASTM C 506 for arch pipe, or
 - ASTM C 507 for horizontal elliptical pipe.

Provide precast concrete pipe that is machine-made or cast by a process that will provide for uniform placement of the concrete in the form and compaction by mechanical devices that will assure a dense concrete. Mix concrete in a central batch plant or other approved batching facility where the quality and uniformity of the concrete is assured. Do not use transit-mixed concrete for precast concrete pipe. When sulfate-resistant concrete is required, do not use Class C fly ash.

Do not place more than 2 holes for lifting and placing in the top section of precast pipe. Cast, cut, or drill the lifting holes in the wall of the pipe. The maximum hole diameter is 3 in. at the inside surface of the pipe wall and 4 in. at the outside surface. Do not cut more than 1 longitudinal wire or 2 circumferential wires per layer of reinforcing steel when locating lift holes.

B. Design.

- 1. General.** The class and D-load equivalents are shown in Table 1. Furnish arch pipe in accordance with ASTM C 506 and the dimensions shown in Table 2. Furnish horizontal elliptical pipe in accordance with ASTM C 507 and the dimensions shown in Table 3. For arch pipe and horizontal elliptical pipe the minimum height of cover required is 1 ft.

Table 1
Circular Pipe
ASTM C 76 & ASTM C 655

Class	D-Load
I	800
II	1,000
III	1,350
IV	2,000
V	3,000

Table 2
Arch Pipe

Design Size	Equivalent Diameter (in.)	Rise (in.)	Span (in.)
1	18	13-1/2	22
2	21	15-1/2	26
3	24	18	28-1/2
4	60	22-1/2	36-1/4
5	36	26-5/8	43-3/4
6	42	31-5/16	51-1/8
7	48	36	58-1/2
8	54	40	65
9	60	45	73
10	72	54	88

Table 3
Horizontal Elliptical Pipe

Design Size	Equivalent Diameter (in.)	Rise (in.)	Span (in.)
1	18	14	23
2	24	19	30
3	27	22	34
4	30	24	38
5	33	27	42
6	36	29	45
7	39	32	49
8	42	34	53
9	48	38	60
10	54	43	68

464.2 to 464.2

2. **Jacking, Boring, or Tunneling.** Design pipe for jacking, boring, or tunneling considering the specific installation conditions such as the soil conditions, installation methods, anticipated deflection angles, and jacking stresses. When requested, provide design notes and drawings signed and sealed by a Texas licensed professional engineer.
- C. **Physical Test Requirements.** Acceptance of the pipe will be determined by the results of the following tests:
- material tests required in ASTM C 76, C 655, C 506, or C 507,
 - absorption tests in accordance with ASTM C 497,
 - three-edge bearing tests in accordance with ASTM C 497 (Perform 3-edge bearing tests on 1 pipe for each 300 pipes or fraction thereof for each design or shape, size, class, or D-load produced within 30 calendar days. Test for the load to produce a 0.01-in. crack or 15% in excess of the required D-load, whichever is less. Test the pipe to ultimate load if so directed. Tested pipe that satisfies the requirements of Section 464.2.F., “Causes for Rejection,” may be used for construction. As an alternate to the 3-edge bearing test, concrete pipe 54 in. in diameter and larger may be accepted on the basis of compressive strength of cores cut from the wall of the pipe. The manufacturer must determine the compressive strength of the samples. Obtain, cure, prepare, and test the cores in accordance with ASTM C 497. The manufacturer must plug and seal core holes in the pipe wall after testing.), and
 - inspection of the finished pipe to determine its conformance with the required design and its freedom from defects.
- D. **Marking.** Clearly mark the following information on each section of pipe:
- class or D-load of pipe,
 - ASTM designation,
 - date of manufacture,
 - name or trademark of the manufacturer, and
 - pipe to be used for jacking and boring.

For pipe with elliptical reinforcement, clearly mark 1 end of each section during the process of manufacture or immediately thereafter. Mark the pipe on the inside and the outside of opposite walls to show the location of the top or bottom of the pipe as it should be installed unless the external shape of the pipe is such that the correct position of the top and bottom is obvious. Mark the pipe section by indenting or painting with waterproof paint.

- E. Inspection.** Provide facilities and access to allow for inspection regarding the quality of materials, the process of manufacture, and the finished pipe at the pipe manufacturing plant. In addition, provide access for inspection of the finished pipe at the project site before and during installation.
- F. Causes for Rejection.** Individual sections of pipe may be rejected for any of the following:
- fractures or cracks passing through the shell, with the exception of a single end crack that does not exceed the depth of the joint;
 - defects that indicate imperfect proportioning, mixing, and molding;
 - surface defects indicating honeycombed or open texture;
 - damaged ends where such damage would prevent making a satisfactory joint;
 - any continuous crack having a surface width of 0.01 in. or more and extending for a length of 12 in. or more.
- G. Repairs.** Make repairs if necessary because of occasional imperfections in manufacture or accidental damage during handling. The Engineer may accept pipe with repairs that are sound, properly finished, and cured in conformance with pertinent specifications.
- H. Rejections.** Allow access for the marking of rejected pipe. Rejected pipe will be plainly marked by the Engineer by painting colored spots over the Department monogram on the inside wall of the pipe and on the top outside wall of the pipe. The painted spots will be no larger than 4 in. in diameter. The rejected pipe will not be defaced in any other manner. Remove the rejected pipe from the project and replace with pipe meeting the requirements of this Item.
- I. Jointing Materials.** Use any of the materials described herein for the making of joints, unless otherwise shown on the plans. Furnish a manufacturer's certificate of compliance for all jointing materials except mortar.
1. **Mortar.** Provide mortar for joints that meets the requirements of Section 464.3.C, "Jointing."
 2. **Cold-Applied, Plastic Asphalt Sewer Joint Compound.** Provide a material that consists of natural or processed asphalt base, suitable volatile solvents, and inert filler. The consistency is to be such that the ends of the pipe can be coated with a layer of the compound up to 1/2 in. thick by means of a trowel. Provide a joint compound that cures to a firm, stiff plastic condition after application. Provide a material of a uniform mixture. If any small

464.3 to 464.3

separation occurs in the container, stir to a uniform mix before using.

Provide a material that meets the requirements of Table 4 when tested in accordance with Tex-526-C.

Table 4
Cold-Applied, Plastic Asphalt Sewer Joint Compound
Material Requirements

Composition	Analysis
Asphalt base, 100%–% volatiles–% ash, % by weight	28–45
Volatiles, 212°F evaporation, 24 hr., % by weight	10–26
Mineral matter, determined as ash, % by weight	30–55
Consistency, cone penetration, 150 q, 5 sec., 77°F	150–275

- 3. Rubber Gaskets.** Provide gaskets that conform to ASTM C 361 or C 443. Meet the requirements of ASTM C 443 for design of the joints and permissible variations in dimensions.
- 4. Pre-Formed Flexible Joint Sealants.** Pre-formed flexible joint sealants may be used for sealing joints of tongue-and-groove concrete pipe. Provide flexible joint sealants that meet the requirements of ASTM C 990. Use flexible joint sealants that do not depend on oxidizing, evaporating, or chemical action for its adhesive or cohesive strength. Supply in extruded rope form of suitable cross section. Provide a size of the pre-formed flexible joint sealant in accordance with the manufacturer’s recommendations and large enough to properly seal the joint. Flexible joint sealants must be protected by a suitable wrapper, and the jointing material must maintain integrity when the wrapper is removed.

464.3. Construction.

- A. Excavation, Shaping, Bedding, and Backfill.** Excavate, shape, bed, and backfill in accordance with Item 400, “Excavation and Backfill for Structures,” except where jacking, boring, or tunneling methods are permitted. Jack, bore, or tunnel the pipe in accordance with Item 476, “Jacking, Boring, or Tunneling Pipe or Box.” If joints consist of materials other than mortar, immediate backfilling is permitted. Take special precautions in placing and compacting the backfill to avoid any movement of the pipe or damage to the joints. Unless otherwise shown on the plans or permitted in writing, do not use heavy earth-moving equipment to haul over the structure until a minimum of 4 ft. of

permanent or temporary compacted fill has been placed over the structure. Remove and replace pipe damaged by the Contractor at no expense to the Department.

- B. Laying Pipe.** Unless otherwise authorized, start the laying of pipe on the bedding at the outlet end with the spigot or tongue end pointing downstream, and proceed toward the inlet end with the abutting sections properly matched, true to the established lines and grades. Fit, match, and lay the pipe to form a smooth, uniform conduit. Where bell-and-spigot pipe is used, cut cross trenches in the foundation to allow the barrel of the pipe to rest firmly upon the bedding. Do not cut cross trenches more than 2 in. larger than the bell ends of the pipe. Lower sections of pipe into the trench without damaging the pipe or disturbing the bedding and the sides of the trench. Carefully clean the ends of the pipe before the pipe is placed. Prevent the earth or bedding material from entering the pipe as it is laid. When elliptical pipe with circular reinforcing or circular pipe with elliptical reinforcing is used, lay the pipe in the trench so that the markings for the top or bottom are not more than 5° from the vertical plane through the longitudinal axis of the pipe. Remove and re-lay, without extra compensation, pipe that is not in alignment or that shows excessive settlement after laying.

Lay multiple lines of reinforced concrete pipe with the centerlines of the individual barrels parallel. Unless otherwise shown on the plans, use the clear distances between outer surfaces of adjacent pipes shown in Table 5. For arch pipe or horizontal elliptical pipe use the equivalent diameter from Table 2 or Table 3 to determine the clear distance requirement in Table 5.

Table 5
Minimum Clear Distance between Pipes

Equivalent Diameter	Min. Clear Distance
18 in.	9 in.
24 in.	11 in.
30 in.	1 ft. 1 in.
36 in.	1 ft. 3 in.
42 in.	1 ft. 5 in.
48 in.	1 ft. 7 in.
54 in.	1 ft. 11 in.
60 to 84 in.	2 ft.

C. **Jointing.** Make available an appropriate rolling device similar to an automobile mechanic's "creeper" for conveyance through small-size pipe structures.

1. **Joints Sealed with Hydraulic Cement Mortar.** Use mortar consisting of 1 part cement, 2 parts sand, and enough water to make a plastic mix. Clean and wet the pipe ends before making the joint. Plaster the lower half of the bell or groove and the upper half of the tongue or spigot with mortar. After the pipes are tightly jointed, pack mortar into the joint from both inside and outside the pipe. Finish the inside smooth and flush with adjacent joints of pipe. For tongue-and-groove joints, form a bead of semicircular cross section over the joint outside the pipe, extending at least 1 in. on each side of the joint. For bell-and-spigot joints, form the mortar to a 45° fillet between the outer edge of the bell and the spigot. Cure mortar joints by keeping the joints wet for at least 48 hr. or until the backfill has been completed, whichever comes first. When mortar joints are used, do not place fill or backfill until the jointing material has cured for at least 6 hr. Do not conduct jointing when the atmospheric temperature is at or below 40°F. Protect mortared joints against freezing by backfilling or other approved methods for at least 24 hr.

Driveway culverts do not require mortar banding on the outside of the pipe.

With approval, pipes that are large enough for a person to enter may be furnished with the groove between 1/2 in. and 3/4 in. longer than the tongue. Such pipe may be laid and backfilled without mortar joints. After the backfilling has been completed, clean the space on the interior of the pipe between the end of the tongue and the groove of all foreign material, thoroughly wet and fill with mortar around the entire circumference of the pipe, and finish flush.

2. **Joints Using Cold-Applied, Plastic Asphalt Sewer Joint Compound.** Ensure that both ends of the pipes are clean and dry. Trowel or otherwise place a 1/2-in.-thick layer of the compound in the groove end of the pipe covering at least 2/3 of the joint face around the entire circumference. Next, shove home the tongue end of the next pipe with enough pressure to make a tight joint. After the joint is made, remove any excess mastic projecting into the pipe. Backfill after the joint has been inspected and approved.

3. **Joints Using Rubber Gaskets.** Make the joint assembly according to the recommendations of the gasket manufacturer. When using rubber gaskets, make joints watertight. Backfill after the joint has been inspected and approved.
4. **Joints Using Pre-Formed Flexible Joint Sealants.** Install pre-formed flexible joint sealants in accordance with the manufacturer's recommendations. Place the joint sealer so that no dirt or other deleterious materials come in contact with the joint sealing material. Pull or push home the pipe with enough force to properly seal the joint. Remove any joint material pushed out into the interior of the pipe that would tend to obstruct the flow. When the atmospheric temperature is below 60°F, store pre-formed flexible joint sealants in an area warmed to above 70°F or artificially warm to this temperature in an approved manner. Apply flexible joint sealants to pipe joints immediately before placing pipe in trench, and then connect pipe to previously laid pipe. Backfill after the joint has been inspected and approved.

D. Connections and Stub Ends. Make connections of concrete pipe to existing pipes, pipe storm drains, or storm drain appurtenances as shown on the plans.

Mortar or concrete the bottom of existing structures if necessary to eliminate any drainage pockets created by the connections. Repair any damage to the existing structure resulting from making the connections.

Unless otherwise shown in the plans, make connections between concrete pipe and corrugated metal pipe with a suitable concrete collar having a minimum thickness of 4 in.

Finish stub ends for connections to future work not shown on the plans by installing watertight plugs into the free end of the pipe.

Fill lift holes with concrete, mortar, or precast concrete plugs after the pipe is in place.

464.4. Measurement. This Item will be measured by the foot. Measurement will be made between the ends of the pipe barrel along the flow line, not including safety end treatments. Safety end treatments will be measured in accordance with Item 467, "Safety End Treatment." Pipe that will be jacked, bored, or tunneled will be measured in accordance with Item 476, "Jacking, Boring, or Tunneling Pipe or Box." Measurement of spurs, branches, or new connecting pipe will be made from the intersection of the flow line with the outside surface of the pipe into which it connects. Where inlets, headwalls, catch basins, manholes, junction chambers, or

464.4 to 465.2

other structures are included in lines of pipe, the length of pipe tying into the structure wall will be included for measurement, but no other portion of the structure length or width will be included.

For multiple pipes, the measured length will be the sum of the lengths of the barrels.

This is a plans quantity measurement Item. The quantity to be paid is the quantity shown in the proposal unless modified by Article 9.2. "Plans Quantity Measurement." Additional measurements or calculations will be made if adjustments of quantities are required.

464.5. Payment. The work performed and materials furnished in accordance with this Item and measured as provided under "Measurement" will be paid for at the unit price bid for "Reinforced Concrete Pipe," "Reinforced Concrete Pipe (Arch)," or "Reinforced Concrete Pipe (Elliptical)" of the size and D-load specified or of the size and class specified. This price is full compensation for constructing, furnishing, transporting, placing, and joining pipes; shaping the bed; cutting pipes on skew or slope; connecting to new or existing structures; breaking back, removing, and disposing of portions of the existing structure; replacing portions of the existing structure; cutting pipe ends on skew or slope; and equipment, labor, tools, and incidentals.

Protection methods for excavations greater than 5 ft. deep will be measured and paid for as required under Item 402, "Trench Excavation Protection," or Item 403, "Temporary Special Shoring." Excavation, shaping, bedding, and backfill will be paid for in accordance with Item 400, "Excavation and Backfill for Structures." When jacking, boring, or tunneling is used at the Contractor's option, payment will be made under this Item. When jacking, boring or tunneling is required, payment will be made under Item 476, "Jacking, Boring or Tunneling Pipe or Box."

ITEM 465

MANHOLES AND INLETS

465.1. Description. Construct manholes and inlets, complete in place or to the stage detailed, including furnishing and installing frames, grates, rings and covers. Drainage junction boxes are classified as manholes.

465.2. Materials. Furnish materials in accordance with the following:

- Item 420, "Concrete Structures"
- Item 421, "Hydraulic Cement Concrete"

- Item 440, “Reinforcing Steel”
- Item 471, “Frames, Grates, Rings, and Covers.”

Precast manholes, inlets, risers, and appurtenances are acceptable unless otherwise shown. Alternate designs for precast items must be acceptable to the Engineer and not deviate from the functional dimensions given.

Alternate designs are to be designed and sealed by a licensed professional engineer.

- A. Concrete.** Furnish Class A concrete for cast-in-place manholes and inlets unless otherwise shown on the plans. Furnish Class A concrete or concrete meeting ASTM C 478 for precast manholes and inlets. Air-entrained concrete will not be required in precast concrete members.
- B. Mortar.** Furnish mortar composed of 1 part hydraulic cement and 2 parts clean sand. Hydrated lime or lime putty may be added to the mix to a maximum of 10% by weight of the total dry mix.
- C. Bricks.** Furnish first-quality, sound, perfectly shaped bricks. Provide clay or shale bricks that are homogeneous and thoroughly and uniformly hard-burned and that meet ASTM C 32, Grade MS or MM. Provide concrete bricks meeting ASTM C 55, Type I (Grade S-I). The maximum allowable water absorption of completely dry bricks is 16% by weight when submerged in water for 24 hr.
- D. Concrete Blocks.** Provide concrete blocks that meet ASTM C 139.
- E. Cast Iron or Aluminum.** Provide supports and steps conforming to the shape and dimensions shown on the plans that meet the requirements of ASTM A 48, Class 35B, for gray iron castings or ASTM A 536, Grade 65-45-12, for ductile iron castings. Steps may also be aluminum meeting ASTM B 221, Alloy 6005-T5. Provide steps in accordance with ASTM C 478, Section 16, “Steps and Ladders.”
- F. Timber.** Provide sound timber for temporary covers when used with Stage I construction (see Section 465.3, “Construction”) that is a minimum of 3 in. nominal thickness and reasonably free of knots and warps.
- G. Other Materials.** Commercial-type hardware of other materials may be used with prior approval.

465.3. Construction.

- A. General.** All types of manholes and inlets may be built either in 1 stage or in 2 stages, described as Stage I and Stage II. Build manholes and inlets designed to match the final roadway surface in stages. Construct

465.3 to 465.3

Stage II after the pavement structure is substantially complete unless otherwise approved by the Engineer.

Construct the Stage I portion of manholes and inlets as shown on the plans or as specified in this Item. Furnish and install a temporary cover as approved by the Engineer.

For Stage I construction of cast iron or steel inlet units, furnish and install the sewer pipe and a temporary plug for the exposed end of the sewer pipe from the storm sewer to a point below the top of curb indicated on the plans.

For Stage II, construct the remaining wall height and top of manhole or inlet and furnish and install any frames, grates, rings and covers, manhole steps, curb beams, or collecting basins required.

Construct precast manholes and inlets in accordance with Item 420, "Concrete Structures," or ASTM C 478. Construct cast-in-place manholes and inlets in accordance with Item 420. Forms will be required for all concrete walls. Multi-project fabrication plants (as defined in Item 424, "Precast Concrete Structures (Fabrication)") that produce manholes and inlets will be approved by the Construction Division in accordance with DMS-7340, "Qualification Procedure for Multi-Project Fabrication Plants of Precast Concrete Manholes and Inlets." The Construction Division maintains a list of approved multiproject plants. Outside wall forms for cast-in-place concrete may be omitted with the approval of the Engineer if the surrounding material can be trimmed to a smooth vertical face. The outside form for concrete bases supporting brick walls may be omitted. Cast steps into the concrete walls when the concrete is placed, or drill and grout steps in place after concrete placement. Mortar steps into joints for brick walls. Use a full bed of mortar for brick work so the brick will thoroughly bond to the mortar. Construct full mortar joints no more than 1/2 in. wide for brick walls. Furnish a header course or bond course (laid perpendicular to the preceding courses) every fifth course of brick.

- B. Manholes and Inlets for Precast Concrete Pipe Sewers.** Construct manholes and inlets for precast concrete pipe sewers as soon as is practicable after sewer lines into or through the manhole or inlet locations are completed. Neatly cut all sewers at the inside face of the walls of the manhole or inlet and point up with mortar.
- C. Manholes and Inlets for Monolithic Pipe Sewers.** Construct bases for manholes and inlets on monolithic pipe sewers either monolithically with the sewer or after the sewer is constructed.

- D. Manholes for Box Sewers.** Cast bases for manholes for box sewers as an integral part of the sewer. Construct manholes before backfilling, or cover the manhole opening temporarily and backfill the sewer as a whole.
- E. Inverts.** Shape and route floor inverts passing out or through the manhole or inlet as shown on the plans. Shape by adding and shaping mortar or concrete after the base is cast or by placing the required additional material with the base.
- F. Finishing Complete Manholes and Inlets.** Complete manholes and inlets in accordance with the plans. Backfill to original ground elevation in accordance with Item 400, "Excavation and Backfill for Structures."
- G. Finishing Stage I Construction.** Complete Stage I construction by constructing the walls to the elevations shown on the plans and backfilling to required elevations in accordance with Item 400, "Excavation and Backfill for Structures."
- H. Stage II Construction.** Construct subgrade and base course or concrete pavement construction over Stage I manhole or inlet construction, unless otherwise approved by the Engineer. Excavate to expose the top of Stage I construction and complete the manhole or inlet in accordance with the plans and these Specifications, including backfill and cleaning of all debris from the bottom of the manhole or inlet.
- I. Inlet Units.** Install cast iron or steel inlet units in conjunction with the construction of concrete curb and gutter. Set the inlet units securely in position before placing concrete for curb and gutter. Form openings for the inlets and recesses in curb and gutter as shown on the plans. Place and thoroughly consolidate concrete for curb and gutter adjacent to inlets and around the inlet castings and formed openings and recesses without displacing the inlet units.

465.4. Measurement. All manholes and inlets satisfactorily completed in accordance with the plans and specifications will be measured by each manhole or inlet, complete, or by each manhole or inlet completed to the stage of construction required by the plans. Extension to inlets will be measured by each extension separately from the inlet.

465.5. Payment. The work performed and materials furnished in accordance with this Item and measured as provided under "Measurement" will be paid for as follows:

466.1 to 466.2

- A. Complete Manholes.** Payment for complete manholes will be made at the unit price bid for “Manhole (Complete)” of the type specified.
- B. Complete Inlets.** Payment for inlets will be made at the unit price bid for “Inlet (Complete),” of the type specified.
- C. Inlet Extensions.** Payment for inlet extensions will be made at the unit price bid for “Inlet Extension” of the type specified.
- D. Manholes Stage I.** Payment for Manholes, Stage I, will be made at the unit price bid for each “Manhole (Stage I)” of the type specified.
- E. Manholes Stage II.** Payment for Manholes, Stage II, will be made at the unit price bid for each “Manhole (Stage II)” of the type specified.
- F. Inlets Stage I.** Payment for Inlets, Stage I, will be made at the unit price bid for each “Inlet (Stage I)” of the type specified.
- G. Inlets Stage II.** Payment for Inlets, Stage II, will be made at the unit price bid for each “Inlet (Stage II)” of the type specified.

These price are full compensation for concrete, reinforcing steel, brick, mortar, aluminum and castings, frames, grates, rings and covers, excavation, and backfill and for all other materials, tools, equipment, labor, and incidentals.

ITEM 466

HEADWALLS AND WINGWALLS

466.1. Description. Furnish, construct, and install concrete headwalls and wingwalls for drainage structures and underpasses.

466.2. Materials.

- A. General.** Furnish materials in accordance with the following:
 - Item 420, “Concrete Structures”
 - Item 421, “Hydraulic Cement Concrete”
 - Item 440, “Reinforcing Steel.”

Unless otherwise shown on the plans, use Class C concrete for cast-in-place and precast concrete units. Furnish cast-in-place or precast headwalls and wingwalls unless otherwise shown on the plans.

B. Fabrication.

- 1. General.** Fabricate cast-in-place concrete units and precast units in accordance with Item 420, “Concrete Structures.” For headwalls and wingwalls use the following definitions:

- “Headwalls” refers to all walls, including wings, at the ends of single-barrel and multiple-barrel pipe culvert structures.
 - “Wingwalls” refers to all walls at the ends of single-barrel or multiple-barrel box culvert structures.
2. **Lifting Holes.** For precast units, provide no more than 4 lifting holes in each section. Lifting holes may be cast, cut into fresh concrete after form removal, or drilled. Provide lifting holes large enough for adequate lifting devices based on the size and weight of the section. The maximum hole diameter is 3 in. at the inside surface of the wall and 4 in. at the outside surface. Do not cut more than 1 longitudinal wire or 2 circumferential wires per layer of reinforcing steel when locating lift holes. Repair spalled areas around lifting holes.
 3. **Marking.** Before shipment from the casting or fabrication yard, clearly mark the following on each precast unit:
 - the date of manufacture,
 - the name or trademark of the manufacturer, and
 - the type and size designation.
 4. **Storage and Shipment.** Store precast units on a level surface. Do not place any loads on precast concrete units until design strength is reached. Do not ship units until design strength requirements have been met.
 5. **Causes for Rejection.** Precast units may be rejected for not meeting any one of the specification requirements. Individual units may also be rejected for fractures or cracks passing through the wall or surface defects indicating honeycombed or open texture surfaces. Remove rejected units from the project, and replace them with acceptable units meeting the requirements of this Item.
 6. **Defects and Repairs.** Occasional imperfections in manufacture or accidental damage sustained during handling may be repaired. The repaired units will be acceptable if they conform to the requirements of this Item and the repairs are sound, properly finished, and cured in conformance with pertinent specifications.

466.3. Construction.

- A. **General.** Remove portions of existing structures in accordance with Item 430.3, “Construction.” Drill, dowel, and grout in accordance with Item 420, “Concrete Structures.”

466.4 to 466.5

- B. Excavation, Shaping, Bedding, and Backfill.** Excavate, shape, bed, and backfill in accordance with Item 400, “Excavation and Backfill for Structures.” Take special precautions in placing and compacting the backfill to avoid any movement or damage to the units. Bed precast units on foundations of firm and stable material accurately shaped to conform to the bases of the units.
- C. Placement of Precast Units.** Provide adequate means to lift and place the precast units. Fill lifting holes with mortar or concrete and cure. Precast concrete or mortar plugs may be used.
- D. Connections.** Make connections to new or existing structures in accordance with the details shown on the plans. Furnish jointing material in accordance with Item 464, “Reinforced Concrete Pipe,” or as shown on the plans.

When removing existing headwalls, also remove a length of the existing pipe from the headwall to the joint as shown on the plans or as approved. Re-lay the removed pipe if approved, or furnish and lay a length of new pipe.

466.4. Measurement. This is a plans quantity measurement item. The quantity to be paid is the quantity shown in the proposal unless modified by Article 9.2, “Plans Quantity Measurement.” Additional measurements or calculations will be made if adjustments of quantities are required.

- A. Headwalls.** Headwalls will be measured by each end of a structure.
- B. Wingwalls.** Wingwalls will be measured by one of the following methods:
 - 1. Square Foot.** Wingwalls will be measured by the square foot of the front surface area of the wall of each type. Unless otherwise shown on the plans, the area will be measured from the top of the footing or apron to the top of the wall. If there is no footing or apron, then measurement is from the bottom of the wall.
 - 2. Each.** Wingwalls will be measured by each end of a structure.

466.5. Payment. The work performed and materials furnished in accordance with this Item and measured as provided under “Measurement” will be paid for at the price bid for “Headwalls” of the type and pipe size (diameter or design) specified, “Wingwalls” of the type specified when measurement is by the square foot, or “Wingwalls” of the type and wall height specified when measurement is by each. For payment purposes, the wingwall height will be rounded to the nearest foot. This price is full compensation for constructing, furnishing, transporting, and installing the

headwalls or wingwalls; connecting to existing structure; breaking back, removing and disposing of portions of the existing structure, and replacing portions of the existing structure as required to make connections; excavation and backfill; and concrete, reinforcing steel, corrugated metal pipe or reinforced concrete pipe, equipment, labor, tools, and incidentals.

Apron concrete or riprap between or around the wingwalls of single- or multiple-barrel box culvert structures will be measured and paid for in accordance with Item 432, "Riprap."

The removal and re-laying of existing pipe or the furnishing of new pipe to replace existing pipe will not be paid for directly but will be considered subsidiary to this Item.

ITEM 467

SAFETY END TREATMENT

467.1. Description. Furnish, construct, and install safety end treatments for drainage structures.

467.2. Materials.

A. General. Furnish materials in accordance with the following:

- Item 420, "Concrete Structures"
- Item 421, "Hydraulic Cement Concrete"
- Item 432, "Riprap"
- Item 440, "Reinforcing Steel"
- Item 442, "Metal for Structures"
- Item 445, "Galvanizing"
- Item 460, "Corrugated Metal Pipe"
- Item 464, "Reinforced Concrete Pipe."

Unless otherwise shown on the plans, use Class C concrete for cast-in-place and precast concrete units. Furnish cast-in-place or precast safety end treatments unless otherwise shown on the plans. Furnish Class B concrete for concrete riprap unless otherwise shown on the plans. Provide galvanized steel for prefabricated metal end sections in accordance with Item 460, "Corrugated Metal Pipe."

Furnish pipe runners in accordance with the following:

- ASTM A 53, Type E or S, Grade B;
- ASTM A 500, Grade B; or
- API 5L, Grade X42.

467.2 to 467.2

Furnish plates and angles in accordance with ASTM A 36. Furnish nuts and bolts in accordance with ASTM A 307. Galvanize pipes, plates, angles, nuts, and bolts in accordance with Item 445, "Galvanizing."

- B. Fabrication.** Fabricate cast-in-place concrete units and precast units in accordance with Item 420, "Concrete Structures." Unless otherwise shown on the plans, when corrugated metal pipe (CMP) is specified for the pipe structure, provide either prefabricated metal end sections or mitered CMP.

Unless otherwise shown on the plans, when reinforced concrete pipe (RCP) is specified for the pipe structure, provide one of the following:

- mitered RCP or
 - precast safety end treatment (SET) units. For this alternative, provide riprap only if the plans specifically require it for precast SET units.
1. **SET Types.**
 - a. **Type I.** Provide Type I SET consisting of reinforced concrete headwalls or wingwalls and pipe runners in accordance with the details shown on the plans when required.
 - b. **Type II.** Provide Type II SET in accordance with the details shown on the plans consisting of the following:
 - CMP or RCP mitered to the proper slope, concrete riprap and pipe runners, when required;
 - prefabricated metal end sections, concrete riprap and pipe runners, when required; or
 - precast SET units, concrete riprap, when required, and pipe runners, when required.
 2. **Lifting Holes.** For precast units, provide no more than 4 lifting holes in each section. Lifting holes may be cast, cut into fresh concrete after form removal, or drilled. Provide lifting holes large enough for adequate lifting devices based on the size and weight of the section. The maximum hole diameter is 3 in. at the inside surface of the wall and 4 in. at the outside surface. Do not cut more than 1 longitudinal wire or 2 circumferential wires per layer of reinforcing steel when locating lift holes. Repair spalled areas around lifting holes.
 3. **Marking.** Prior to shipment from the casting or fabrication yard, clearly mark the following on each precast unit, mitered CMP, mitered RCP, or metal end section:

- the date of manufacture,
 - the name or trademark of the manufacturer, and
 - the type and size designation.
4. **Storage and Shipment.** Store precast units on a level surface. Do not place any loads on precast units until the design strength is reached. Do not ship units until design strength requirements have been met.
 5. **Causes for Rejection.** Precast units may be rejected for not meeting any one of the specification requirements. Individual units may also be rejected for fractures or cracks passing through the wall or surface defects indicating honeycombed or open texture surfaces. Remove rejected units from the project and replace them with acceptable units meeting the requirements of this Item.
 6. **Defects and Repairs.** Occasional imperfections in manufacture or accidental damage sustained during handling may be repaired. The repaired units will be acceptable if they conform to the requirements of this Item and the repairs are sound and properly finished and cured in conformance with pertinent specifications. Repair damaged galvanizing in accordance with Section 445.3.D, "Repairs."

467.3. Construction.

- A. **General.** Remove portions of existing structures in accordance with Article 430.3, "Construction." Drill, dowel, and grout in accordance with Item 420, "Concrete Structures." Furnish concrete riprap in accordance with Item 432, "Riprap."

Provide riprap on all prefabricated metal end sections.
- B. **Excavation, Shaping, Bedding, and Backfill.** Excavate, shape, bed, and backfill in accordance with Item 400, "Excavation and Backfill for Structures." Take special precautions in placing and compacting the backfill to avoid any movement or damage to the units. Bed precast units on foundations of firm and stable material accurately shaped to conform to the bases of the units.
- C. **Placement of Precast Units.** Provide adequate means to lift and place the precast units. Fill lifting holes with mortar or concrete and cure. Precast concrete or mortar plugs may be used.
- D. **Connections.** Make connections to new or existing structures in accordance with the details shown on the plans. Furnish jointing material in accordance with Item 464, "Reinforced Concrete Pipe."

467.4 to 467.5

When removing existing headwalls, also remove a length of the existing pipe from the headwall to the joint as shown on the plans or as approved. Re-lay the removed pipe if approved, or furnish and lay a length of new pipe.

467.4. Measurement. SETs of all types will be measured by each barrel of each structure end.

467.5. Payment. The work performed and materials furnished in accordance with this Item and measured as provided under “Measurement” will be paid for at the unit price bid for the various designations of “Safety End Treatment” specified as follows:

- SET (Type I) (Barrel Span) (Wall Height) (Slope, Horizontal:Vertical) (Orientation, Cross or Parallel)
- SET (Type I) (Pipe Diameter or Design) (Slope, Horizontal:Vertical) (Orientation, Cross or Parallel)
- SET (Type II) (Pipe Diameter or Design) (Pipe Material) (Slope, Horizontal:Vertical) (Orientation, Cross or Parallel)

For payment purposes, the wingwall heights of Type I SETs for box culverts will be rounded to the nearest foot.

This price is full compensation for constructing, furnishing, transporting, and installing the end treatments; connecting to existing structure; breaking back, removing and disposing of portions of the existing structure, and replacing portions of the existing structure as required to make connections; excavation and backfill; furnishing concrete, reinforcing steel, corrugated metal pipe or reinforced concrete pipe, and pipe runners; and concrete riprap, nuts, bolts, plates, angles, equipment, labor, tools, and incidentals.

The removal and re-laying of existing pipe or the furnishing of new pipe to replace existing pipe will not be paid for directly but will be considered subsidiary to this Item.

The mitered length of CMP or RCP that is a part of the SET (Type II) will not be paid for directly but will be considered subsidiary to this Item. The limits for payment for pipe will be as shown on the plans and paid for in accordance with the pertinent bid item.

The limits of riprap to be included in the price bid for each SET will be shown on the plans. Any riprap placed beyond the limits shown will be paid in accordance with Item 432, “Riprap.” Riprap between multiple precast SET units will be required as shown on the plans and is included in the price bid for SET.

When precast SETs are provided as an option to mitered RCP, riprap aprons will not be required unless the plans specifically require riprap aprons for precast SET units. The plans will show the limits of the riprap to be included with the precast SET for payment.

ITEM 471

FRAMES, GRATES, RINGS, AND COVERS

471.1. Description. Furnish and install frames, grates, rings and covers for inlets, manholes, and other structures.

471.2. Materials.

A. Welded Steel Grates and Frames. Provide welded steel grates and frames as an assembly conforming to the member size, dimensions, and details shown on the plans. Fabricate these assemblies in accordance with Item 441, "Steel Structures." Use steel that meets ASTM A 36 or equal.

B. Frame, Grate, Ring, and Cover Castings. Provide clean castings conforming to the shape and dimensions shown on the plans. Ensure that the castings are free from sand and blow holes or other defects and that surfaces of the castings are reasonably smooth. Remove runners, risers, fins, and other cast-on pieces from the castings, and grind these areas smooth. Cast or machine the bearing surfaces between manhole rings and covers and between grates and frames with such precision that uniform bearing is provided throughout the perimeter area of contact. Matchmark pairs of machined castings for proper identification at installation.

Provide steel castings conforming to ASTM A 27. Furnish Grade 70-36 unless otherwise specified. Provide gray iron castings conforming to ASTM A 48, Class 35B. Provide ductile iron castings conforming to ASTM A 536. Use Grade 65-45-12 unless otherwise specified. Frame, grate, ring, and cover castings must meet the proof-load testing requirements of AASHTO M 306. Use commercial type frames, rings, risers or appurtenances only with prior approval of the Engineer.

C. Documentation. Furnish mill test reports or manufacturer's certification to the Engineer for each lot or shipment of steel and iron materials. For castings, also furnish a manufacturer's certification stating that the casting meets the proof-load testing requirements of AASHTO M 306.

471.3 to 472.3

471.3. Construction. Construct and install frames, grates, rings, and covers in accordance with the details shown on the plans. Weld in accordance with Item 448, "Structural Field Welding." Tack-weld grates and covers to the frame or ring when directed by the Engineer.

Galvanize steel castings and welded steel grates and frames in accordance with Item 445, "Galvanizing." Galvanizing is not required for iron castings unless used in conjunction with structural steel shapes or shown on the plans.

Provide galvanized bolts and nuts in accordance with Item 445, "Galvanizing."

471.4. Measurement. Frames, grates, rings, and covers, when a part of the complete manhole or inlet, will not be measured for payment but will be considered subsidiary to Item 465, "Manholes and Inlets." Frames, grates, rings, and covers, when not a part of a Manhole (complete) or Inlet (complete), will be measured by the each.

471.5. Payment. When payment is required in accordance with "Measurement," payment for frames, grates, rings, and covers will be made at the unit price bid for "Grate," "Frame," "Grate and Frame," "Frame and Cover," or "Ring and Cover." This price is full compensation for equipment, materials, labor, tools, and incidentals.

ITEM 472

REMOVING AND RE-LAYING CULVERT AND STORM DRAIN PIPE

472.1. Description. Remove, transport, clean, and re-lay existing culvert and storm drain pipe.

472.2. Materials. Bituminous coating must meet the requirements of Section 460.2.B, "Protective Coating."

472.3. Construction. Culvert and storm drain pipe to be removed and re-laid will be shown on the plans. Remove debris and sediment within the culvert and storm drain pipe. Clean joints to facilitate proper re-laying. Install concrete pipe in accordance with Item 464, "Reinforced Concrete Pipe." Install corrugated metal pipe in accordance with Item 460, "Corrugated Metal Pipe." Excavate, bed, and backfill in accordance with Item 400, "Excavation and Backfill for Structures." Prevent damage to the

pipe and fittings. Make connections to existing structures as shown on the plans and in conformance to the requirements for connections as described in pertinent pipe specifications. Connect reinforced concrete pipe to corrugated metal pipe with a suitable concrete collar having a minimum thickness of 4 in. or as shown on the plans. Use a coating of bituminous material to insulate portions of aluminum pipe that are to be in contact with metal other than aluminum. Extend coating 1 ft. minimum beyond area of contact. Mark the top and bottom of reinforced concrete pipe before removal and reinstall in the same position. If shown on the plans, reuse headwall, aprons, or other appurtenances by severing from the culvert and moving to the new position. Make connections for joining sections of pipes in accordance with pertinent Items.

If items designated for reuse are damaged by the Contractor, replace them with new material or restore them to previous condition, as approved. The Contractor may remove and dispose of existing structures and construct new structures at no expense to the Department in accordance with pertinent specifications and designs shown on the plans or as approved.

472.4. Measurement. This Item will be measured by the foot between the ends of the pipe barrel along the flow line as installed. Where spurs, branches, or connections to the existing pipe lines are involved, measurement of the spur or connecting pipe will be made from the intersection at the flow line with the outside surface of the pipe into which the pipe connects. Where inlets, catch basins, manholes, safety end treatments, or other structures are included in lines of pipe, the length of pipe tying into the structure wall will be included for measurement but no other portion of the structure length or width will be included.

472.5. Payment. The work performed and materials furnished in accordance with this Item and measurement as provided under "Measurement" will be paid for at the unit price bid for "Removing and Re-laying Pipe" of the size specified. This price is full compensation for excavating and removing pipe from its original location; loading, hauling, placing, and joining pipe; cutting pipe ends on skew or slope; moving and reusing headwalls and safety end treatments; connections to existing structures; concrete collars and reinforcing; and equipment, materials, labor, tools, and incidentals. Removal and disposal of pipe and appurtenances not reused will be subsidiary to the bid items of the contract. Protection methods for excavations greater than 5 ft. in depth will be measured and paid for as required under Item 402, "Trench Excavation Protection," or Item 403, "Temporary Special Shoring." Excavation, bedding, and backfill for re-laying pipe will be paid for in accordance with Item 400, "Excavation

472.5 to 473.5

and Backfill for Structures.” When jacking, boring, or tunneling is used at the Contractor’s option, payment will be made under this Item. When jacking, boring, or tunneling is required, payment will be made under Item 476, “Jacking, Boring, or Tunneling Pipe or Box.”

ITEM 473

LAYING CULVERT AND STORM DRAIN PIPE

473.1. Description. Install furnished culvert and storm drain pipe.

473.2. Materials. Pipe furnished may be new or salvaged or a combination of both. Bituminous coating must meet the requirements of Section 460.2.B, “Protective Coating.”

473.3. Construction. Obtain and haul pipe from designated locations. Excavate, bed, and backfill in accordance with Item 400, “Excavation and Backfill for Structures.” Install concrete pipe in accordance with Item 464, “Reinforced Concrete Pipe.” Install corrugated metal pipe in accordance with Item 460, “Corrugated Metal Pipe.” Make connections to existing structures as shown on the plans and in conformance to the requirements for connections in the pertinent pipe specifications or as approved. Connect reinforced concrete pipe to corrugated metal pipe with a suitable concrete collar having a minimum thickness of 4 in. or as shown on the plans. Use a coating of bituminous material to insulate portions of aluminum pipe that are to be in contact with metal other than aluminum. Extend the coating a 1 ft. minimum beyond area of contact. Replace Contractor-damaged items designated for reuse with new material, or restore to previous condition as approved.

473.4. Measurement. This Item will be measured by the foot between the ends of the pipe barrel along the flow line as installed. Where spurs or branches or connections to existing pipe lines are involved, measurement of the spur or connecting pipe will be made from the intersection of the flow line with the outside surface of the pipe into which the pipe connects. Where inlets, manholes, safety end treatments, or other structures are included in lines of pipe, that length of pipe tying into the structure wall will be included for measurement, but no other portion of the structure length or width will be included.

473.5. Payment. The work performed and materials furnished in accordance with this Item and measured as provided under “Measurement”

will be paid for at the unit price bid for “Laying Pipe” of the size specified. This payment is full compensation for loading, hauling, placing, and joining pipe; cutting pipe ends on skew or slope; connections to existing structures; cutting pipe to proper length; concrete collars and reinforcement; and equipment, materials, labor, tools, and incidentals. Protection methods for excavations greater than 5 ft. in depth will be measured and paid for as required under Item 402, “Trench Excavation Protection,” or Item 403, “Temporary Special Shoring.” Excavation, bedding, and backfill for laying pipe will be paid for in accordance with Item 400, “Excavation and Backfill for Structures.” When jacking, boring, or tunneling is used at the Contractor’s option, payment will be made under this Item. When jacking, boring or tunneling is required, payment will be made under Item 476, “Jacking, Boring, or Tunneling Pipe or Box.”

ITEM 474 SLOTTED DRAIN

474.1. Description. Furnish, fabricate, and install slotted drains and slotted drain outfalls.

474.2. Materials. Fabricate and furnish materials in accordance with Item 460, “Corrugated Metal Pipe.” Furnish galvanized steel or aluminized steel (AASHTO M 36, Type 2) pipe with a minimum thickness of 16 gauge.

- A. Slotted Drains.** Slotted drains consist of a drain guide assembly attached to a longitudinal opening in a corrugated metal pipe. Unless otherwise specified on the plans, fabricate slotted drains using either of the following drain guide assemblies.
- 1. Type A.** Provide bearing bars and crossbar spacers meeting the requirements of ASTM A 36, welded to the longitudinal opening in the corrugated metal pipe. Galvanize the drain guide assembly after fabrication in accordance with Item 445, “Galvanizing.” Clean and repair welded areas and heat-affected zones in accordance with Section 445.3.D, “Repairs.”
 - 2. Type B.** Machine-form the drain guide assembly from 14 gauge or thicker galvanized steel sheeting that meets the requirements of Item 460, “Corrugated Metal Pipe.”
- B. Slotted Drain Outfalls.** Slotted drain outfalls consist of the corrugated metal pipe that connects the slotted drain to the main drainage line.

474.3 to 476.2

- C. Backfill.** Provide cement-stabilized backfill in accordance with Item 400, "Excavation and Backfill for Structures," or high-slump, low-strength concrete with a minimum of 180 lb. of cement per cubic yard.

474.3. Construction. Install slotted drains and slotted drain outfalls in accordance with details on the plans and the requirements of Item 460, "Corrugated Metal Pipe." Excavate and backfill in accordance with Item 400, "Excavation and Backfill for Structures." Backfill trenches as shown on the plans or as directed. Furnish slotted drains in 20-ft. lengths, minimizing the number of joints required.

474.4. Measurement. This Item will be measured by the foot between the ends of the pipe along the flow line.

This is a plans quantity measurement Item. The quantity to be paid is the quantity shown in the proposal unless modified by Article 9.2, "Plans Quantity Measurement." Additional measurements or calculations will be made if adjustments of quantities are required.

474.5. Payment. The work performed and materials furnished in accordance with this Item and measured as provided under "Measurement" will be paid for at the unit price bid for "Slotted Drain" or "Slotted Drain Outfall" of the material type and nominal pipe diameter specified. This price is full compensation for furnishing and transporting the drain pipe, excavation and backfill, placing and joining the drain pipe, joint connection bands, concrete backfill, cement-stabilized backfill, equipment, labor, tools, and incidentals.

ITEM 476

JACKING, BORING, OR TUNNELING PIPE OR BOX

476.1. Description. Furnish and install pipe or box by jacking, boring, or tunneling.

476.2. Materials. Use the following types of pipe or box:

- corrugated metal pipe meeting Item 460, "Corrugated Metal Pipe," of the size, type, design, and dimension shown on the plans;
- reinforced concrete pipe meeting the special requirements for jacking, boring, or tunneling of Item 464, "Reinforced Concrete Pipe," of the size, strength, and dimension shown on the plans;

- reinforced concrete box meeting Item 462, “Concrete Box Culverts and Storm Drains,” of the size and type shown on the plans; or
- other types specified by the plans.

476.3. Construction. Excavate suitable shafts or trenches for conducting the jacking, boring, or tunneling operations and for placing end joints of the pipe or box if the grade at the jacking, boring, or tunneling end is below the ground surface. Protect excavations deeper than 5 ft. as specified in Item 402, “Trench Excavation Protection” or Item 403, “Temporary Special Shoring.”

Install pipe or box so there is no interference with the operation of street, highway, railroad, or other facility and no embankment or structure is weakened or damaged.

Repair any pipe or box damaged in jacking, boring, or tunneling. Remove and replace any pipe or box damaged beyond repair at the Contractor’s expense.

Immediately after installation of pipe or box, backfill shafts or trenches excavated to facilitate jacking, boring, or tunneling.

A. Jacking. Provide jacks suitable for forcing the pipe or box through the embankment. Use even pressure to all jacks during operation. Provide a suitable jacking head and suitable bracing between the jacks and the jacking head to apply uniform pressure around the ring of the pipe or circumference of the box. Use joint cushioning of plywood or other approved material. For plywood cushioning material, use 1/2-in. minimum thickness for pipe diameter 30 in. or less, and use 3/4-in. minimum thickness for pipe diameter greater than 30 in. Use 3/4-in. minimum thickness for all boxes. Use cushioning rings of single or multiple pieces. Provide a suitable jacking frame or backstop. Set the pipe or box to be jacked on guides that support the section of the pipe or box, and direct it on the proper line and grade. Place the entire jacking assembly in line with the direction and grade of the pipe or box. In general, excavate the embankment material just ahead of the pipe or box, remove the material through the pipe or box, and force the pipe or box through the embankment with jacks into the space provided.

Furnish a plan showing the proposed method of jacking for approval. Include the design for the jacking head, jacking support or backstop, arrangement and position of jacks, and guides in the plan.

Ensure that excavation for the underside of the pipe for at least 1/3 of the circumference of the pipe conforms to the contour and grade of the pipe. Ensure that the excavation for the bottom slab of the box

476.3 to 476.3

conforms to the grade of the box. If desired, over excavate to provide not more than 2 in. of clearance for the upper portion of the pipe or box. Taper this clearance to zero at the point where the excavation conforms to the contour of the pipe or box. Pressure-grout any over excavation of more than 1 in.

The distance that the excavation extends beyond the end of the pipe or box must not exceed 2 ft. Decrease this distance as necessary to maintain stability of the material being excavated.

Jack the pipe or box from the low or downstream end. The final position of the pipe or box must not vary from the line and grade shown on the plans by more than 1 in. in 10 ft. Variation must be regular and in 1 direction, and the final flow line must be in the direction shown on the plans.

If desired, use a cutting edge of steel plate around the head end of the pipe or box extending a short distance beyond the end.

B. Boring. Bore from a shaft in an approved location provided for the boring equipment and workmen.

Dispose of excavated material using a method approved by the Engineer. Use water or other fluids in connection with the boring operation only as necessary to lubricate cuttings; do not use jetting.

In unconsolidated soil formations, use a gel-forming colloidal drilling fluid consisting of high-grade, carefully processed bentonite to consolidate cuttings of the bit, seal the walls of the hole, and furnish lubrication for subsequent removal of cuttings and immediate installation of the pipe.

Allowable variations from line and grade are specified in Section 476.3.A, "Jacking." Pressure-grout any over excavation of more than 1 in.

Use a pilot hole or auger method for the boring.

- 1. Pilot Hole Method.** Bore a 2-in. pilot hole the entire length of the crossing, and check it for line and grade on the opposite end of the bore from the work shaft. This pilot hole will serve as centerline for the larger diameter hole to be bored.
- 2. Auger Method.** Use a steel encasement pipe of the appropriate diameter equipped with a cutter head to mechanically perform the excavation. Use augers of sufficient diameter to convey the excavated material to the work shaft.

- C. Tunneling.** Use an approved tunneling method where the characteristics of the soil, the size of the proposed pipe, or the use of monolithic pipe would make the use of tunneling more satisfactory than jacking or boring or when shown on the plans.

When tunneling is permitted, ensure that the lining of the tunnel is of sufficient strength to support the overburden. Submit the proposed liner method for approval. Approval does not relieve the Contractor of the responsibility for the adequacy of the liner method.

Pressure-grout the space between the liner plate and the limits of excavation.

- D. Joints.** If corrugated metal pipe is used, make joints by field bolting or by connecting bands, whichever is feasible. If reinforced concrete pipe is used, make the joints in accordance with Item 464, "Reinforced Concrete Pipe." If reinforced concrete box is used, make the joints in accordance with Item 462, "Concrete Box Culverts and Storm Drains."

476.4. Measurement. This Item will be measured by the foot between the ends of the pipe or box along the flow line.

This is a plans quantity measurement Item. The quantity to be paid is the quantity shown in the proposal, unless modified by Article 9.2, "Plans Quantity Measurement." Additional measurements or calculations will be made if adjustments of quantities are required.

476.5. Payment. The work performed and materials furnished in accordance with this Item and measured as provided under "Measurement" will be paid for at the unit price bid for "Jacking, Boring, or Tunneling Pipe" of the type, size, and class specified; or "Jacking, Boring, or Tunneling Pipe" of the type, size, and design specified; or "Jacking or Tunneling Box Culvert" of the size specified.

This price is full compensation for excavation, grouting, backfilling, and disposal of surplus material; furnishing pipe, box, and pipe liner materials required for tunnel operations; preparation, hauling, and installing of pipe, box, and pipe liner materials; and materials, tools, equipment, labor, and incidentals.

Protection methods for open excavations deeper than 5 ft. will be measured and paid for as required under Item 402, "Trench Excavation Protection," or Item 403, "Temporary Special Shoring."

ITEM 479

ADJUSTING MANHOLES AND INLETS

479.1. Description. Adjust or cap existing manholes or inlets. Drainage junction boxes will be classified as manholes.

479.2. Materials. Reuse removed manhole and inlet rings, plates, grates, covers, and brick if they are in good condition as determined by the Engineer. Provide additional materials in accordance with Item 465, "Manholes and Inlets," at no cost to the Department. Single- or multiple-piece prefabricated metal extension rings may be used for the adjustment of manholes as approved. Provide concrete that meets Item 421, "Hydraulic Cement Concrete."

479.3. Construction. Perform all work in accordance with Item 465, "Manholes and Inlets." Excavate and backfill in accordance with Item 400, "Excavation and Backfill for Structures." Carefully remove manhole and inlet rings, covers, plates, and grates to be reused. Clean mortar and grease from the contact areas of all reused items. Dispose of unused removed material as directed. Use construction methods described in Sections 479.3.A, "Lowering the Top of a Manhole or Inlet," and 479.3.B, "Raising the Top of a Manhole or Inlet," unless otherwise shown on the plans.

- A. Lowering the Top of a Manhole or Inlet.** Remove a sufficient depth of brick courses or concrete to permit reconstruction on a batter not exceeding 1 in. horizontal to 2 in. vertical. Where brickwork is present, clean the mortar from the top course of brick. Rebuild the manhole or inlet to the original top dimensions or to the dimensions shown in the plans. Install the manhole or inlet ring and the cover, plate, or grate to conform to the proposed new surface contour.
- B. Raising the Top of a Manhole or Inlet.** Clean the top surface of brick or concrete. Construct to the proper new elevation using new brick, brick salvaged from other manholes or inlets, prefabricated metal extension rings, concrete rings, or Class A concrete. Install the manhole or inlet ring and the cover, plate, or grate to conform to the proposed new surface contour. Install prefabricated extension rings in accordance with manufacturer's instructions.
- C. Capping an Inlet or Manhole.** Remove the inlet or manhole to a minimum of 1 ft. below subgrade elevation or as indicated on the plans. Cap as shown on the plans.

479.4. Measurement. Adjusted or capped manholes or inlets will be measured as each manhole or inlet adjusted.

479.5. Payment. The work performed and materials furnished in accordance with this Item and measured as provided under “Measurement” will be paid for at the unit price bid for “Adjusting Manholes,” “Adjusting Inlets,” or “Adjusting Manholes and Inlets.” This price is full compensation for materials, including backfill as required, and for excavation, tools, equipment, labor, and incidentals.

ITEM 480

CLEANING EXISTING CULVERTS

480.1. Description. Remove all extraneous material from existing culvert barrels and pipes.

480.2. Work Methods. Expose all inside surfaces of the specified culverts. Do not move or damage the culvert. Dispose of material in accordance with federal, state, and local regulations. Place on roadway slopes when approved.

Perform cleaning to maintain drainage during construction. Acceptance of the cleaned culverts occurs at final acceptance of the project in accordance with Article 4.6, “Final Cleanup,” unless otherwise shown on the plans.

480.3. Measurement. This Item will be measured by each complete culvert cleaned regardless of the number of barrels or pipes at each location or by the cubic yard. If measurement is by the cubic yard, the volume of material to be removed will be computed by the method of average end areas in its original position.

480.4. Payment. The work performed in accordance with this Item and measured as provided under “Measurement” will be paid for at the unit price bid for “Cleaning Existing Culverts.” This price is full compensation for excavation, disposal of excavated material, equipment, labor, tools, and incidentals.

481.1 to 481.3

ITEM 481 PVC PIPE FOR DRAINS

481.1. Description. Furnish and install polyvinyl chloride (PVC) pipe for drains.

481.2. Materials. Furnish PVC pipe meeting the requirements of ASTM D 1785, Schedule 40, and furnish PVC fittings meeting the requirements of ASTM D 2466. PVC pipe and fittings meeting the requirements of ASTM D 3034, Type SDR 35 may be used for installations encased in concrete or buried in soil.

Furnish a manufacturer's certification stating the material meets the appropriate ASTM specification.

Furnish pipe marked with:

- manufacturer's name or trademark and code;
- nominal size;
- PVC cell classification (example: 12454-B);
- schedule, size, or other legend (example: SDR-35 PVC Sewer Pipe); and
- specification designation (example: ASTM D 1785).

Furnish fittings marked with:

- manufacturer's name or trademark;
- nominal size;
- material designation (example: PVC);
- schedule, size, or other legend (example: Schedule 40); and
- specification designation (example: ASTM D 3034).

Furnish solvent meeting the requirements of ASTM D 2564 for solvent-welding of fittings.

Provide fittings, hangers, clamps, straps, anchors, and guard plates in accordance with the details shown on the plans.

481.3. Construction. Excavate and backfill for pipe installation in accordance with Item 400, "Excavation and Backfill for Structures." Install pipe as shown on the plans or as directed. Solvent-weld all fittings, including splice fittings, to provide a watertight fit. Do not splice straight sections of pipe at intervals shorter than 20 ft. unless at the end of a run or otherwise approved.

Unless otherwise shown on the plans, degrease all exposed PVC pipe and fittings, and apply an acrylic water-based primer followed by a coating of the same color used for adjacent concrete surfaces.

481.4. Measurement. This Item will be measured by the foot along the centerline of the installed pipe of the nominal size shown on the plans.

481.5. Payment. The work performed and materials furnished in accordance with this Item and measured as provided under “Measurement” will be paid for at the unit price bid for “PVC Pipe” of the sizes and types specified. This price is full compensation for furnishing and installing the PVC pipe and for fittings, hangers, clamps, straps, anchors, guard plates, painting, equipment, labor, tools, and incidentals. Excavation and backfill will not be paid for directly but will be considered subsidiary to this Item.

ITEM 483

SCARIFYING CONCRETE BRIDGE SLAB

483.1. Description. Scarify concrete bridge slabs. Remove and dispose of the cuttings produced.

483.2. Equipment. Provide scarifying equipment capable of:

- maintaining accurate depth of cut and slope,
- accurately establishing profile grades along each edge of the machine,
- automatically controlling cross slope at a given rate,
- uniformly varying the depth of cut while the machine is in motion, and
- controlling dust created by the cutting action.

Unless otherwise permitted, provide a machine equipped with integral loading and reclaiming devices to immediately remove the cuttings from the surface of the roadway and discharge them into a truck, all in a single operation.

Provide chipping tools to remove concrete in small areas not accessible to the mechanical scarifier.

483.3. Construction. Scarify the existing concrete slab to a uniform rough surface having a chipped appearance suitable for bonding a concrete overlay. Scarify at locations shown on the plans or as directed to the depths shown on the plans. Measure the depth from the level of the existing surface to the high points on the scarified surface.

Take appropriate care to prevent damage to the bridge slab reinforcing steel, armored joints, slab joints, drainage hardware, and other appurtenances.

When appropriate or required, establish and maintain independent grade control for concrete scarifying operations.

483.4 to 490.3

Use chipping tools to remove concrete in small areas not accessible to the mechanical scarifier.

Immediately clean the surface of the deck to remove all cuttings and debris. Dispose of all cuttings and debris in locations outside the right of way.

483.4. Measurement. This Item will be measured by the square yard of scarified area of existing concrete surfaces.

Uniform cuts and tapered cuts of varying depth made in accordance with the plans will be measured by the square yard for the nominal depth of scarifying specified.

483.5. Payment. The work performed and equipment furnished in accordance with the Item and measured as provided under “Measurement” will be paid for at the unit price bid for “Scarifying Concrete Bridge Slab.” This price is full compensation for removing all material to the depths shown; texturing the surface; loading, hauling, unloading, and disposing of the cuttings; and equipment, labor, tools, and incidentals.

ITEM 490

TIMBER STRUCTURES

490.1. Description. Construct timber structures and timber portions of structures.

490.2. Materials. Supply materials in accordance with details shown on the plans.

- A. Timber.** Supply timber in accordance with Item 491, “Timber for Structures.”
- B. Hardware.** Galvanize all hardware including nails, except cast and malleable iron washers, in accordance with Item 445, “Galvanizing.” Hardware may be cast or malleable iron or cut from steel plate as specified. Use bolts, pins, washers, and spikes of the size and type specified.

490.3. Construction. Construct structures in accordance with the plans. Complete all cutting and boring of timber before treatment if practical. Ensure that all framing is true and exact. Drive nails and spikes to set the heads flush with the surface of the wood without making deep hammer marks in wood surfaces. Accurately cut all lumber and timber, and frame it so that the joints have even bearing over the entire contact surface. Use

washers under bolt heads and nuts. Countersink hardware when smooth or flush surfaces are required. Remove all bolt stock projecting beyond 1/4 in. from the top of the nut.

- A. Storage and Handling of Timber.** Store timber in piles at the worksite. Stack timber at least 12 in. above the ground surface. Arrange timber to shed water and allow air circulation to prevent warping. Protect it from weather. Clear the ground of weeds and rubbish underneath and near material piles. Handle timber without dropping, breaking outer fibers, or bruising. Use slings or other approved equipment. Provide corner protectors when using metal bands to bundle members.
- B. Stringers.** Size stringers to uniform depth at bearings, and place in position so knots near edges will be in the top portions of the stringers. Lay stringers with the crown up if practical. Stringers may have butt joints or lapped joints. Stagger the joints when stringers are 2 panels in length. Fasten all stringers securely by bolts or nails as shown on plans.
- C. Bridging.** Frame cross-bridging or diaphragms between stringers neatly and accurately, and securely toe-nail with at least 2 nails in each end.
- D. Flooring.** Use glued laminated deck panels or single planks as shown on the plans. Place planks for single-plank floors with the heart side down. Provide 1/4-in. openings between planks for seasoned materials and tight joints for unseasoned or treated material. Spike each plank to each stringer or nailing strip firmly with spikes at least 3 in. longer than the thickness of the plank. Cut off the ends of the plank on a line parallel with the centerline of the roadway. Select the planks according to thickness, and lay them so that no 2 adjacent planks vary in thickness by more than 1/8 in.
- E. Wheel Guards.** Lay wheel guards in sections at least 12 ft. long except where shorter sections are necessary to match end joints.
- F. Railings.** Stagger butt joints so adjacent rail joints do not occur on the same post. Bolt connections wherever possible.
- G. Holes for Bolts, Dowels, Rods, and Lag Screws.** Bore holes for round drift bolts and dowels with a bit 1/16 in. less in diameter than the bolt or dowel. Bore holes for square drift bolts or dowels equal to the least dimension of the bolt or dowel. Bore holes for machine bolts the same diameter as the bolt. Bore holes for rods 1/16 in. greater than the diameter of the rod. Bore holes for lag screws with a bit no larger than the root of the thread and 1/2 in. deeper than the penetration of the lag

490.4 to 491.2

screws and equal to the diameter of the shank for the length of the shank.

- H. **Field Treatment.** After cutting and drilling, treat cuts and drilled holes in treated piling or timbers and all abrasions as specified in Item 492, “Timber Preservative and Treatment.”
- I. **Painting.** Paint in accordance with details shown on the plans.

490.4. Measurement and Payment. The work performed, materials furnished, equipment, labor, tools, and incidentals will not be measured or paid for directly but will be subsidiary to bid items of the Contract.

ITEM 491 TIMBER FOR STRUCTURES

491.1. Description. Furnish and place lumber and timber.

491.2. Materials. Furnish materials in accordance with details shown on the plans. Treat all lumber and timber in accordance with Item 492, “Timber Preservative and Treatment,” unless otherwise shown on the plans. All material must bear the grade mark of an approved American Lumber Standards Committee agency or the identification mark of a state-approved inspection agency. A grade mark or identification mark must be on the timber before treating.

- A. **Finish.** Provide material for railings, flooring, and wheel guards that is surfaced on 4 sides. Dress other timber as indicated on the plans.
- B. **Timber and Lumber.** Use No. 1 Southern Pine or other materials required by the plans. Use the stress grade indicated on the plans. Timber grade designations refer to standard designations of the Southern Pine Inspection Bureau Standard Grading Rules. Use grading methods and general requirements that conform to the “General Requirements for Stress Grades” in ASTM D 245.
- C. **Structural Glued Laminated Timber.** Meet the grade, species, and other requirements outlined in ANSI/AITC A-190.1, “Specification for Glued Laminated Timber.” Bond all members with wet-use adhesive conforming to ASTM D 2559. Treat individual laminations with preservative before gluing.
- D. **Sign Posts.** Use No. 1 Southern Pine, dried before treatment to 19% maximum moisture content. Do not use compression wood on any face. Compression wood is allowed if wholly enclosed in the piece, at least 6

annual rings from the surface, and not more than 1/4 in. wide in its maximum dimension.

491.3. Equipment. Use slings or other approved equipment for handling. Do not use equipment that may damage the surface of the wood.

491.4. Construction. Construct timber structures in accordance with requirements of Item 490, “Timber Structures.”

491.5. Measurement. Timber will be measured by the 1,000 board feet, computed on nominal sizes and the shortest commercial lengths practical for use.

491.6. Payment. The work performed and materials furnished in accordance with this Item and measured as provided under “Measurement” will be paid for at the unit price bid for “Treated Timber” or “Untreated Timber.” This price is full compensation for materials, hardware, equipment, tools, labor, painting, preservative treatment, and incidentals. Timber used for erection purposes that is not part of the permanent structure will not be paid for directly but will be subsidiary to this Item. Timber piling will be paid for under Item 406, “Timber Piling.”

ITEM 492

TIMBER PRESERVATIVE AND TREATMENT

492.1. Description. Pressure treat piles, posts, timbers, and lumber with preservative.

492.2. Materials. Treating plants furnishing treated-timber products must meet the requirements of AWPA Standard M3, Part A. All treaters except treaters of structural glued laminated timber must be Department-approved and enter into a stocking agreement with the Department. The Construction Division maintains a list of approved treating plants. Fabricators of structural glued laminated timber must be certified by AITC. A list of certified fabricators of structural glued laminated timber is maintained by the AITC. AWPA standards govern materials and methods of treatments including seasoning, preservatives, and inspection for treatment. Provide the level of preservative indicated in Table 1.

A. Inspection. Provide access for the Inspector to all parts of facilities used in the conditioning and treating of timber products in accordance with Article 6.5, “Plant Inspection and Testing.” The supplier must

492.2 to 492.2

provide necessary assistance for the proper inspection of the materials being furnished.

B. Identification. An AITC quality inspected mark must be placed on each fabricated piece of structural glued laminated timber. Each piece or bundle of other treated-timber products must have a legible brand mark or tag indicating the name of the treater, date of treatment or lot number, and the AWPAs treatment specification symbol. Furnish a completed Department “Certification of Compliance” form with every shipment of treated timber products.

**Table 1
Minimum Retention of Preservative**

Product	Creosote (lb./cu. ft.)	Creosote–Coal Tar Solution (lb./cu. ft.)	Penta-chlorophenol (lb./cu. ft.)	ACA ¹ or CCA ² (lb./cu. ft.)	AWPA Standard for Treatment
AWPA Preservative Standard	P1/P13	P2	(P8/P9)	P5	
Timber piling for land or freshwater use, including foundation piles ³	12		0.6		C3
Timber piling for use in coastal waters ³	20	20			C18
Round guard fence posts ⁴	10		0.5	0.5	C14
Rectangular guard fence posts ⁴	12		0.6	0.5	C14
Guard fence blocks ⁴	10		0.5	0.5	C14
Wire fence posts (round) ⁴	8		0.4	0.4	C5
Sign posts ⁴	10		0.5	0.4	C14
Timber and lumber ⁵	12		0.6	0.6	C14
Structural glued laminated timber ^{6,7}	10		0.6	0.4	C28

1. Ammoniacal copper arsenate.

2. Chromated copper arsenate.

3. Retention determined by assay (0 to 3.0-in. zone except 0 to 2.0-in. zone for foundation piles in land and freshwater use).

4. Retention determined by assay (0 to 1.0-in. zone).

5. Retention determined by assay (0 to 0.6-in. zone for up to 2-in.-thick material, and 0 to 1.0-in. zone for over 2-in.-thick material).

6. Retention determined by assay (0.5 to 1.0-in. zone).

7. Treat individual laminations before gluing.

- C. Field Treatment.** When it is necessary to bore holes or to cut pressure-treated materials after treatment or when any treated surface is badly scarred, treat the hole, cut, or scarred surface with multiple applications of liquid preservative as specified in AWWA Standard M4. When required, furnish liquid preservative for field treatment.

492.3. Measurement and Payment. The work performed, materials furnished, equipment, labor, tools, equipment, and incidentals will not be measured or paid for directly but will be subsidiary to pertinent Items.

ITEM 495

RAISING EXISTING STRUCTURES

495.1. Description. Raise existing structures as shown on the plans.

495.2. Materials. Furnish materials in accordance with the following:

- Item 420, “Concrete Structures”
- Item 421, “Hydraulic Cement Concrete”
- Item 442, “Metal for Structures”
- Item 434, “Elastomeric Bridge Bearings.”

495.3. Construction. Submit detailed plans to raise structure. Approval of plans is required before beginning raising work. A licensed professional engineer must sign and seal the plans. Clearly indicate the methods, materials, cribbing, falsework or other supports, and equipment proposed. Repair or replace by an approved method any portions of the structure damaged by the raising operation. Approval of these plans does not relieve the Contractor from responsibility for the completion of the work nor from liability for repair or replacement of damaged portions of the structure due to the methods approved and employed.

A. Preparation of Plans.

1. Apply loads so that the load capacities in bearing, shear, and flexure are not exceeded for any material or member carrying the load. Indicate jack positions and capacities and temporary hardware attachments on the plan. Avoid jacking against the bottom of the slab. Use a jack with a minimum capacity of 2 times the dead load. Prohibit traffic on the structure until the structure is supported by cribbing, falsework, or the final supports.
2. Provide suitable cribbing, falsework, or other supports until the span or unit is resting on its final supports to prevent the various

495.4 to 495.4

spans or units from dropping due to jack failure or other causes during the lifting operation. Design the supports to carry the greater of the following loads:

- 2 times the dead load if traffic is not allowed on the structure or
- 1.3 times the dead load plus 2.17 times the live load including impact if the plans allow traffic on the structure before it is placed on the final supports.

B. Raising of Spans. Before jacking, verify that anchor bolts, closed joints, or other appurtenances do not restrict vertical movement. Jack spans from the existing bent cap or temporary falsework unless otherwise shown on the plans.

Loosen and remove all anchor bolt nuts or cut the anchor bolts to allow free vertical movement before raising. Replace all damaged or cut anchor bolts either by butt welding to existing bolts or by drilling into the existing concrete cap a minimum of 12 in. and grouting in new bolts. Do not damage the bent cap reinforcing steel when installing new anchor bolts. Replace all damaged or lost anchor bolt nuts. Weld in conformance with Item 448, "Structural Field Welding."

Provide adequate guides or force to ensure vertical lifting and prevent drifting of the structure during the jacking operation. Provide pedestals as shown on the plans.

- 1. Simple Spans with an Expansion Joint in the Deck at Every Bent.** Raise the span by jacking as shown on the plans. Raise all of the beams on one side of the bent simultaneously. Do not raise one end of a simple span more than 4 in. before raising the opposite end.
- 2. Simple Beam Spans with a Continuous Deck Over the Bent.** Raise all beams on both sides of the bent simultaneously by jacking according to the plans. Do not raise one end of a span more than 2 in. before raising the opposite end of the span.
- 3. Continuous Beams.** Raise the unit by jacking according to the approved plans. Raise all beams at a single bent simultaneously. The unit may be raised incrementally from bent to bent. Do not raise the unit more than 2 in. at any bent before raising it at the adjacent bents.

495.4. Measurement. This Item will be measured by the lump sum. Material for permanent steel pedestals will be measured in accordance with Item 442, "Metal for Structures," and material for permanent concrete

pedestals will be measured in accordance with Item 420, “Concrete Structures.”

495.5. Payment. The work performed and materials furnished in accordance with this Item and measured as provided under “Measurement” will be paid at the unit price bid for “Raising Existing Structure.” This price is full compensation for shoring, falsework, jacking, fabric pads or elastomeric bearings, labor, tools, and equipment and for all materials except new pedestals. Pedestals will be paid for in accordance with Item 442, “Metal for Structures,” or Item 420, “Concrete Structures.”

ITEM 496

REMOVING STRUCTURES

496.1. Description. Remove and either dispose of or salvage structures.

496.2. Construction.

A. Removal.

1. **Pipes.** Avoid damaging appurtenances determined by the Engineer to be salvageable.
 2. **Concrete, Brick, or Stone Structures.** Portions of structures that will not interfere with the proposed construction may remain in place 2 ft. or more below the permanent ground line. Square off remaining structures and cut reinforcement flush with the surface of the concrete.
 3. **Steel Structures.** Dismantle steel to be retained by the Department or re-erected by cold-cutting fastener heads and punching or drilling the remaining portion of the fastener, air-arc gouging welded connections, and flame-cutting beams along a straight line. The Engineer may approve other methods of cutting. Cut beams at the locations shown in the plans. Match-mark steel to be re-erected with paint in accordance with the erection drawings. Remove steel piles or cut off 2 ft. or more below the permanent ground line.
 4. **Timber Structures.** Remove all fasteners from timber determined by the engineer to be salvageable. Remove timber piles or cut off 2 ft. or more below the permanent ground line.
- B. Salvage.** Avoid damage to materials shown in the plans to be salvaged. Deliver materials to be retained by the Department to the location shown in the plans. Block up salvaged steel materials off the ground.

496.3 to 497.4

- C. Disposal.** Material removed that is not deemed to be salvageable is the property of the Contractor. Dispose of removed material off the right of way in accordance with federal, state, and local regulations.
- D. Backfill.** Backfill excavation and voids to the original ground line if resulting from the removal of structures. Place backfill that will support any portion of the roadbed or embankment to the same requirements for placing embankment. Backfill other areas in 10-in. layers, loose measurement, and compact to the density of adjacent undisturbed material.

496.3. Measurement. This Item will be measured by each structure or by the foot.

496.4. Payment. The work performed in accordance with this Item and measured as provided under “Measurement” will be paid for at the unit price bid for “Removing Structures” of the type of structure specified. This price is full compensation for loading, hauling, disposal, stockpiling, removal of appurtenances, excavation and backfill, equipment, labor, tool, and incidentals.

ITEM 497

SALE OF SALVAGEABLE MATERIAL

497.1. Description. Salvage and remove from existing structures the structural steel, steel railing, or any other material designated for sale to the Contractor. Materials to be salvaged will be shown on the plans.

497.2. Construction. Salvage material for sale to the limits indicated on the plans or as required by other specifications. Remove all materials designated for sale from the project site before final acceptance of the project.

497.3. Measurement. All salvaged structural steel, steel railing, or other material designated for sale to the Contractor will be measured as a lump sum unit.

497.4. Payment. Salvaged material is a credit item to the Department and will be deducted from the Contractor’s monthly construction estimate upon completion of the removal.

ITEM 499
ADJUSTING STEEL SHOES

499.1. Description. Adjust and repair steel shoes, trim beam ends, and clean and paint steel shoes and trimmed beam ends as required at the locations shown on the plans.

499.2. Construction. Remove the existing welds between the shoes and the girder flanges by arc-air gouging. Loosen or remove anchor bolt nuts as required to allow free vertical movement before raising. Jack the girders up to free the shoes and allow the pin between the top and bottom bolsters to rotate freely. If the pin does not rotate freely, drive the pin out and then clean and lubricate it before reinstalling. Repair as shown on the plans or as directed any concrete distress in the bearing area caused by the shoe in accordance with Item 429, "Concrete Structure Repair." Set the shoes relatively plumb for a temperature of 70°F. Lower the girders and reweld the shoes in this position. Use the same weld size as the original weld unless directed otherwise. Weld and grind smooth any excess gouges caused by weld removal. Grind any original weld metal not removed by arc-air gouging. Grind all exposed corners to a 1/16-in. radius. Trim as directed or indicated on the plans beam ends that are encroaching on backwalls or adjacent spans. Perform all welding, trimming, and grinding in accordance with Item 441, "Steel Structures," and Item 448, "Structural Field Welding."

Use jacks with a capacity adequate to raise the girders free of the shoes without exceeding a bearing pressure on the concrete cap of 1,500 psi. Use jacks with a capacity of at least 1.5 times the shoe design load or as indicated on the plans. Repair as directed any concrete spalls caused by the Contractor's operations.

Replace any shoes or parts of shoes as required in accordance with Item 442, "Metal for Structures," and the original details. Replace all damaged or cut anchor bolts by butt-welding to existing bolts in accordance with Item 448, "Structural Field Welding." Replace all damaged or lost anchor bolt nuts.

Clean and paint the shoes and trimmed beam ends in accordance with Item 446, "Cleaning and Painting Steel."

499.3. Measurement. This Item will be measured by each shoe adjusted.

499.4. Payment. The work performed and materials furnished in accordance with this Item and measured as provided under "Measurement"

499.4 to 499.4

will be paid for at the price bid for “Adjusting Steel Shoes.” This price is full compensation for removing the weld between the steel shoe and the girder flange, trimming the beam ends, loosening or removing anchor bolt nuts, jacking the girder, freeing the shoe pin, adjusting and repairing the shoes, replacing any shoes or parts of shoes as necessary, repairing or replacing anchor bolts and nuts, welding, painting, equipment, labor, tools, and incidentals.

500 ITEMS — MISCELLANEOUS CONSTRUCTION**ITEM 500
MOBILIZATION**

500.1. Description. Establish and remove offices, plants, and facilities. Move personnel, equipment, and supplies to and from the project or the vicinity of the project site to begin work or complete work on Contract Items.

500.2. Measurement. This Item will be measured by the lump sum as the work progresses.

500.3. Payment. Partial payments of the lump sum bid for mobilization will be as follows. The adjusted Contract amount for construction Items as used below is defined as the total Contract amount less the lump sum for mobilization.

- A.** Payment will be made upon presentation of a paid invoice for the payment bond, performance bond, and required insurance. The combined payment for bonds and insurance will be no more than 10% of the mobilization lump sum or 1% of the total Contract amount, whichever is less.
- B.** Payment will be made upon verification of documented expenditures for plant and facility setup. The combined amount for all these facilities will be no more than 10% of the mobilization lump sum or 1% of the total Contract amount, whichever is less.
- C.** When 1% of the adjusted Contract amount for construction Items is earned, 50% of the mobilization lump sum bid or 5% of the total Contract amount, whichever is less, will be paid. Previous payments under this Item will be deducted from this amount.
- D.** When 5% of the adjusted Contract amount for construction Items is earned, 75% of the mobilization lump sum bid or 10% of the total Contract amount, whichever is less, will be paid. Previous payments under the Item will be deducted from this amount.
- E.** When 10% of the adjusted Contract amount for construction Items is earned, 90% of the mobilization lump sum bid or 10% of the total Contract amount, whichever is less, will be paid. Previous payments under this Item will be deducted from this amount.

502.1 to 502.2

- F. Payment for the remainder of the lump sum bid for “Mobilization” will be made on the next estimate cycle after the initial retainage estimate or at final acceptance for projects without retainage.

ITEM 502

BARRICADES, SIGNS, AND TRAFFIC HANDLING

502.1. Description. Provide, install, move, replace, maintain, clean, and remove upon completion of work all barricades, signs, cones, lights, and other traffic control devices used for traffic handling as indicated on the plans and as directed.

502.2. Construction. Provide traffic control devices that conform to details shown on the plans, the TMUTCD, and the Compliant Work Zone Traffic Control Device List (CWZTCDL) maintained by the Traffic Operations Division.

- A. **Implementation.** Before beginning work, designate in writing a Contractor’s Responsible Person (CRP) to be the representative of the Contractor who is responsible for taking or directing corrective measures of installation and maintenance deficiencies as soon as possible. The CRP must be accessible by phone and able to respond to emergencies 24 hours per day.

Follow the traffic control plan (TCP) and install traffic control devices as shown on the plans and as directed. Install traffic control devices straight and plumb. Do not make changes to the location of any device or implement any other changes to the TCP without the approval of the Engineer. Minor adjustments to meet field constructability and visibility are allowed.

Submit Contractor-proposed TCP changes, signed and sealed by a licensed professional engineer, to the Engineer for approval. The Engineer may develop, sign, and seal Contractor-proposed changes. Changes must conform to guidelines established in the TMUTCD using approved products from the CWZTCDL.

Maintain traffic control devices by taking corrective action as soon as possible. Corrective action includes but is not limited to cleaning, replacing, straightening, covering, or removing devices. Maintain the devices such that they are properly positioned, spaced, and legible, and that retroreflective characteristics meet requirements during darkness and rain.

- B. Flaggers.** Provide a Contractor representative who has been certified as a flagging instructor through courses offered by the Texas Engineering Extension Service, the American Traffic Safety Services Association, the National Safety Council, or other approved organizations. Provide the certificate indicating course completion when requested. This representative is responsible for training and assuring that all flaggers are qualified to perform flagging duties. A qualified flagger must be independently certified by one of the organizations listed above or trained by the Contractor's certified flagging instructor. Provide the Engineer with a current list of qualified flaggers before beginning flagging activities. Use only flaggers on the qualified list.

Flaggers must be courteous and able to effectively communicate with the public. When directing traffic, flaggers must use standard attire, flags, signs, and signals and follow the flagging procedures set forth in the TMUTCD.

- C. Removal.** Upon completion of work, remove all barricades, signs, cones, lights, and other traffic control devices used for work-zone traffic handling, unless otherwise shown on the plans.

502.3. Measurement. This Item will be measured by the month.

502.4. Payment. The work performed and materials furnished in accordance with this Item and measured as provided under "Measurement" will be paid for at the unit price bid for "Barricades, Signs, and Traffic Handling." This price is full compensation for installation, maintenance, adjustments, replacements, removal, materials, equipment, labor, tools, and incidentals.

When the plans establish pay items for particular work called for in the TCP, that work will be measured and paid for under pertinent Items.

- A. Initiation of Payment.** Payment for this Item will begin on the first estimate after barricades, signs, and traffic handling devices have been installed in accordance with the TCP and construction has begun. Installation of the project limit advance warning signs alone is not considered the beginning of construction.
- B. Paid Months.** Monthly payment will be made each succeeding month for this Item provided the barricades, signs, and traffic handling devices have been installed and maintained in accordance with the TCP until the Contract amount has been paid.

If, within the time frame established by the Engineer, the Contractor fails to provide or properly maintain signs and barricades in compliance

504.1 to 504.2

with the Contract requirements, as determined by the Engineer, the Contractor will be considered in noncompliance with this Item. No payment will be made for the months in question, and the total final payment quantity will be reduced by the number of months the Contractor was in noncompliance.

- C. Maximum Total Payment Prior to Acceptance.** The total payment for this Item will not exceed 10% of the total Contract amount before final acceptance in accordance with Article 5.8, “Final Acceptance.” However, when all work is complete for all project locations, except for work for vegetative establishment and maintenance periods and performance and test periods, the 10% of the total Contract amount may be exceeded. The remaining balance will be paid in accordance with Section 502.4.E, “Balance Due.”
- D. Total Payment Quantity.** The quantity paid under this Item will not exceed the total quantity shown in the plans except as modified by change order and as adjusted by Section 502.4.B, “Paid Months.” An overrun of the plans quantity for this Item will not be allowed for approving designs; testing; material shortages; closed construction seasons; curing periods; establishment, performance, test, and maintenance periods; failure to complete the work in the number of months allotted; nor delays caused directly or indirectly by requirements of the contract.
- E. Balance Due.** If all work is complete and accepted in accordance with Article 5.8, “Final Acceptance,” before payment of the amount allowed by this Article, the balance due will be paid on the next estimate after the initial retainage release estimate or final acceptance for projects without retainage.
- F. Law Enforcement.** Law enforcement required by the Engineer will be paid in accordance with Article 9.5, “Force Account.”

ITEM 504

FIELD OFFICE AND LABORATORY

504.1. Description. Provide field offices and laboratories.

504.2. Equipment.

- A. General.** Furnish facilities after the receipt of the work order to begin work and before beginning physical work on the project. Provide field offices of the type and number specified near the worksite at a location

acceptable to the Engineer. The Contractor may make use of permanent buildings or rental space meeting the requirements for field offices instead of portable buildings if approved. Maintain the field office until the Department accepts the project. Furnish other equipment as required.

Provide inspection laboratories of the type specified before beginning the fabrication of products required by the Contract. Locate the building so that plant operations are visible from the building. Maintain the laboratories until the production of the associated product is complete.

Immediately repair or replace the facility if it is damaged in any manner. Payment for repair will not be made unless it is the result of negligence by the Department. Reimburse the Department for equipment damaged by the Contractor's operations. When facilities are allowed in the right of way, remove buildings and other facilities and restore the right of way before project acceptance.

1. **Parking and Fencing.** Unless otherwise shown on the plans, provide an all-weather parking area for the sole use of at least 2 State-owned vehicles. Situate the area near the field office or laboratory at a location acceptable to the Engineer. Maintain the parking area until the project is completed and restore the area to a condition acceptable to the Engineer upon project completion.

When shown on the plans, enclose the field office or laboratory and the parking area with a 6-ft. chain-link fence, a top-mounted 3-strand barbed wire, and a 12-ft. gate.

2. **Buildings.**

- a. **Field Office.** Provide field offices with roofs, floors, doors, and screened windows. Ensure the floor is of sufficient strength to support testing equipment and has an impervious floor covering. If the Contractor uses part of the structure, do not interconnect the field office with Contractor-used rooms. Ensure that the field office is weatherproof, piped for water and fuel, and electrically wired by personnel meeting the requirements of Article 7.15, "Electrical Requirements."

Furnish and install adequate equipment, outlets, lighting, air conditioning, heating, and ventilation. Provide a partitioned rest room furnished with rest room supplies, a lavatory and a flush toilet connected to a sewer or septic tank. A portable toilet may be used when approved by the Engineer.

504.2 to 504.2

Provide secured and controlled access to the field office or laboratory through the use of security measures such as bars, alarms, or security fencing. Furnish steps to the building if deemed necessary by the Engineer.

b. Laboratory. Provide laboratories with all of the requirements described in Section 504.2.A.2.a, "Field Office." In addition, provide the following items unless otherwise directed:

- laboratory equipment necessary for testing when shown on the plans;
- water (for testing purposes) from an approved source;
- an exhaust fan for concrete curing, asphalt, or other operations to meet Department and OSHA requirements (Vent all exhaust to the outside of the structure.);
- a work platform at least 18 in. long and 12 in. wide, mounted on a lumber post at least 6 in. by 6 in. extending through the floor and firmly fixed in the ground (The work platform support can be provided by other methods as shown on the plans or as directed.);
- a minimum of 20 ft. of total work counter length at least 3 ft. wide and 3 ft. above the floor and of sufficient strength to support required testing equipment; and
- a laboratory sink measuring 24 in. by 30 in. and 12 in. in depth.

3. Field Office and Laboratory Appurtenances. Provide workbenches and tables at least 3 ft. wide and 6 ft. long, chairs, and filing cabinets in the quantity acceptable to the Engineer. Provide solar screens, blinds, or shades if deemed necessary by the Engineer. Provide potable water, electricity, collection and disposal of trash, and janitorial services acceptable to the Engineer.

Provide a telephone and telephone service unless otherwise directed. A cell phone may be provided to meet this requirement.

Provide a paper copier and facsimile when required by the plans.

For Contracts that require a nuclear gauge for moisture or density determination, provide a closet within the facility or a separate structure for storage of the gauge as far as possible from the normal office work. For all doors allowing access to the nuclear gauge, provide internal keyed deadbolt locks and hinges with pins on the inside of the storage area.

Provide any or all of the following, as shown on the plans and in accordance with DMS-10101, "Computer Equipment":

- computers (laptop or desktop),
- printers, and
- Internet service. The Internet service must be provided on a line separate from required phone service.

B. Structure Types.

1. **Type A Structure (Field Laboratory).** Provide at least 200 sq. ft. of gross floor area in rooms 8 ft. high. Partition the building into at least 2 rooms, each furnished with an exterior door and at least 2 windows.
2. **Type B Structure (Field Office and Laboratory).** Provide at least 600 sq. ft. of gross floor area in rooms 8 ft. high. Partition the floor area into at least 3 interconnected rooms with doors, 2 exterior doors, and at least 2 windows in each room.
3. **Type C Structure (Field Office).** Provide at least 400 sq. ft. of gross floor area in rooms 8 ft. high. Partition the floor area into at least 2 interconnected rooms with doors, 2 exterior doors, and at least 2 windows in each room.
4. **Type D Structure (Asphalt Mix Control Laboratory).** Provide at least 700 sq. ft. of gross floor area in rooms 8 ft. high. Partition the floor area into at least 2 interconnected rooms with doors, 2 exterior doors, and at least 2 windows in each room.
 - a. **Asphalt Content by Extraction.** If the asphalt content will be determined by extraction, equip the laboratory portion of this structure with an exhaust fan of sufficient capacity to evacuate the fumes generated by the asphalt extraction procedure. Provide an exhaust fan with an explosion-proof motor capable of reducing fume concentrations to levels below OSHA maximums. Locate the fan below the workbench in the extraction area and exhaust to the outside.

Vent the oven used to dry extracted aggregates to the outside.
 - b. **Asphalt Content by Ignition Method.** If the asphalt content will be determined by the ignition method, provide sufficient power ventilation for the room, a NEMA 6-50R (208/240 V, 50 A) outlet within 3 ft. of the ignition oven location, and an independent exhaust outlet no farther than 8 ft. from the oven. Provide a surface for the ignition oven that is level, sturdy, and fireproof with at least 6 in. of clearance between the furnace and other vertical surfaces.

Vent the ignition oven to the outside.

504.3 to 506.2

5. **Type E Structure.** Provide building as shown on plans.

504.3. Measurement and Payment. The work performed, materials furnished, utilities and utility service (including phone when required), appurtenances (including computers, office equipment and Internet service), testing equipment, labor, tools, and incidentals will not be measured or paid for directly but will be subsidiary to pertinent Items.

ITEM 506

TEMPORARY EROSION, SEDIMENTATION, AND ENVIRONMENTAL CONTROLS

506.1. Description. Install, maintain, and remove erosion, sedimentation, and environmental control devices. Remove accumulated sediment and debris.

506.2. Materials.

A. Rock Filter Dams.

1. **Aggregate.** Furnish aggregate with hardness, durability, cleanliness, and resistance to crumbling, flaking, and eroding acceptable to the Engineer. Provide the following:
 - **Types 1, 2, and 4 Rock Filter Dams.** Use 3 to 6 in. aggregate.
 - **Type 3 Rock Filter Dams.** Use 4 to 8 in. aggregate.
2. **Wire.** Provide minimum 20 gauge galvanized wire for the steel wire mesh and tie wires for Types 2 and 3 rock filter dams. Type 4 dams require:
 - a double-twisted, hexagonal weave with a nominal mesh opening of 2-1/2 in. x 3-1/4 in.;
 - minimum 0.0866 in. steel wire for netting;
 - minimum 0.1063 in. steel wire for selvages and corners; and minimum 0.0866 in. for binding or tie wire.
3. **Sandbag Material.** Furnish sandbags meeting Section 506.2.I, "Sandbags," except that any gradation of aggregate may be used to fill the sandbags.

B. Temporary Pipe Slope Drains. Provide corrugated metal pipe, polyvinyl chloride (PVC) pipe, flexible tubing, watertight connection bands, grommet materials, prefabricated fittings, and flared entrance

sections that conform to the plans. Recycled and other materials meeting these requirements are allowed if approved.

Furnish concrete in accordance with Item 432, "Riprap."

- C. Baled Hay.** Provide hay bales weighing at least 50 lb., composed entirely of vegetable matter, measuring 30 in. or longer, and bound with wire, nylon, or polypropylene string.
- D. Temporary Paved Flumes.** Furnish asphalt concrete, hydraulic cement concrete, or other comparable non-erodible material that conforms to the plans. Provide rock or rubble with a minimum diameter of 6 in. and a maximum volume of 1/2 cu. ft. for the construction of energy dissipaters.
- E. Construction Exits.** Provide materials that meet the details shown on the plans and this Section.
 - 1. Rock Construction Exit.** Provide crushed aggregate for long and short-term construction exits. Furnish aggregates that are clean, hard, durable, and free from adherent coatings such as salt, alkali, dirt, clay, loam, shale, soft, or flaky materials and organic and injurious matter. Use 4- to 8-in. aggregate for Type 1 and 2- to 4-in. aggregate for Type 3.
 - 2. Timber Construction Exit.** Furnish No. 2 quality or better railroad ties and timbers for long-term construction exits, free of large and loose knots and treated to control rot. Fasten timbers with nuts and bolts or lag bolts, of at least 1/2 in. diameter, unless otherwise shown on the plans or allowed. For short-term exits, provide plywood or pressed wafer board at least 1/2 in. thick.
 - 3. Foundation Course.** Provide a foundation course consisting of flexible base, bituminous concrete, hydraulic cement concrete, or other materials as shown on the plans or directed.
- F. Embankment for Erosion Control.** Provide rock, loam, clay, topsoil, or other earth materials that will form a stable embankment to meet the intended use.
- G. Pipe.** Provide pipe outlet material in accordance with Item 556, "Pipe Underdrains," and details shown on the plans.
- H. Construction Perimeter Fence.**
 - 1. Posts.** Provide essentially straight wood or steel posts that are at least 60 in. long. Furnish soft wood posts with a minimum diameter of 3 in. or use 2 x 4 boards. Furnish hardwood posts with

506.2 to 506.2

a minimum cross-section of 1-1/2 x 1-1/5 in. Furnish T- or L-shaped steel posts with a minimum weight of 1.3 lb. per foot.

2. **Fence.** Provide orange construction fencing as approved by the Engineer.
 3. **Fence Wire.** Provide 12-1/2 gauge or larger galvanized smooth or twisted wire. Provide 16 gauge or larger tie wire.
 4. **Flagging.** Provide brightly-colored flagging that is fade-resistant and at least 3/4 in. wide to provide maximum visibility both day and night.
 5. **Staples.** Provide staples with a crown at least 1/2 in. wide and legs at least 1/2 in. long.
 6. **Used Materials.** Previously used materials meeting the applicable requirements may be used if accepted by the Engineer.
- I. **Sandbags.** Provide sandbag material of polypropylene, polyethylene, or polyamide woven fabric with a minimum unit weight of 4 oz. per square yard, a Mullen burst-strength exceeding 300 psi, and an ultraviolet stability exceeding 70%.

Use natural coarse sand or manufactured sand meeting the gradation given in Table 1 to fill sandbags. Filled sandbags must be 24 to 30 in. long, 16 to 18 in. wide, and 6 to 8 in. thick.

**Table 1
Sand Gradation**

Sieve #	Maximum Retained (% by Weight)
4	3%
100	80%
200	95%

- J. **Temporary Sediment Control Fence.** Provide a net-reinforced fence using woven geo-textile fabric. Logos visible to the traveling public will not be allowed.
1. **Fabric.** Provide fabric materials in accordance with DMS-6230, “Temporary Sediment Control Fence Fabric.”
 2. **Posts.** Provide essentially straight wood or steel posts with a minimum length of 48 in., unless otherwise shown on the plans. Soft wood posts must be at least 3 in. in diameter or nominal 2 x 4 in. Hardwood posts must have a minimum cross-section of 1-1/2 x 1-1/2 in. T- or L-shaped steel posts must have a minimum weight of 1.3 lb. per foot.

3. **Net Reinforcement.** Provide net reinforcement of at least 12-1/2 gauge galvanized welded wire mesh, with a maximum opening size of 2 x 4 in., at least 24 in. wide, unless otherwise shown on the plans.
4. **Staples.** Provide staples with a crown at least 3/4 in. wide and legs 1/2 in. long.
5. **Used Materials.** Use recycled material meeting the applicable requirements if accepted by the Engineer.

506.3. Equipment. Provide a backhoe, front end loader, blade, scraper, bulldozer, or other equipment as required when “Earthwork for Erosion Control” is specified on the plans as a bid item.

506.4. Construction.

A. Contractor Responsibilities. Implement the Department’s Storm Water Pollution Prevention Plan (SWP3) for the project site in accordance with the specific or general storm water permit requirements. Develop and implement an SWP3 for project-specific material supply plants within and outside of the Department’s right of way in accordance with the specific or general storm water permit requirements. Prevent water pollution from storm water associated with construction activity from entering any surface water or private property on or adjacent to the project site.

B. General.

1. **Phasing.** Implement control measures in the area to be disturbed before beginning construction, or as directed. Limit the disturbance to the area shown on the plans or as directed. If, in the opinion of the Engineer, the Contractor cannot control soil erosion and sedimentation resulting from construction operations, the Engineer will limit the disturbed area to that which the Contractor is able to control. Minimize disturbance to vegetation.
2. **Maintenance.** Immediately correct ineffective control measures. Implement additional controls as directed. Remove excavated material within the time requirements specified in the applicable storm water permit.
3. **Stabilization.** Stabilize disturbed areas where construction activities will be temporarily stopped in accordance with the applicable storm water permit. Establish a uniform vegetative cover. The project will not be accepted until a 70% density of existing adjacent undisturbed areas is obtained, unless otherwise

506.4 to 506.4

shown on the plans. When shown on the plans, the Engineer may accept the project when adequate controls are in place that will control erosion, sedimentation, and water pollution until sufficient vegetative cover can be established.

4. **Finished Work.** Upon acceptance of vegetative cover, remove and dispose of all temporary control measures, temporary embankments, bridges, matting, falsework, piling, debris, or other obstructions placed during construction that are not a part of the finished work, or as directed.
5. **Restricted Activities.** Do not locate disposal areas, stockpiles, or haul roads in any wetland, water body, or streambed.

Do not install temporary construction crossings in or across any water body without the prior approval of the appropriate resource agency and the Engineer. Restrict construction operations in any water body to the necessary areas as shown on the plans or applicable permit, or as directed. Use temporary bridges, timber mats, or other structurally sound and non-eroding material for stream crossings.

Provide protected storage area for paints, chemicals, solvents, and fertilizers at an approved location. Keep paints, chemicals, solvents, and fertilizers off bare ground and provide shelter for stored chemicals.

- C. **Installation, Maintenance, and Removal Work.** Perform work in accordance with the specific or general storm water permit. Install and maintain the integrity of temporary erosion and sedimentation control devices to accumulate silt and debris until earthwork construction and permanent erosion control features are in place or the disturbed area has been adequately stabilized as determined by the Engineer. If a device ceases to function as intended, repair or replace the device or portions thereof as necessary. Remove sediment, debris, and litter. When approved, sediments may be disposed of within embankments, or in the right of way in areas where the material will not contribute to further siltation. Dispose of removed material in accordance with federal, state, and local regulations.

Remove devices upon approval or when directed. Upon removal, finish-grade and dress the area. Stabilize disturbed areas in accordance with the permit, and as shown on the plans or directed. The Contractor retains ownership of stockpiled material and must remove it from the project when new installations or replacements are no longer required.

1. **Rock Filter Dams for Erosion Control.** Remove trees, brush, stumps, and other objectionable material that may interfere with the construction of rock filter dams. Place sandbags as a foundation when required or at the Contractor's option.

For Types 1, 2, 3, and 5, place the aggregate to the lines, height, and slopes specified, without undue voids. For Types 2 and 3, place the aggregate on the mesh and then fold the mesh at the upstream side over the aggregate and secure it to itself on the downstream side with wire ties, or hog rings, or as directed. Place rock filter dams perpendicular to the flow of the stream or channel unless otherwise directed. Construct filter dams according to the following criteria, unless otherwise shown on the plans:

- a. **Type 1 (Non-reinforced).**

- (1) **Height.** At least 18 in. measured vertically from existing ground to top of filter dam.
- (2) **Top Width.** At least 2 ft.
- (3) **Slopes.** At most 2:1.

- b. **Type 2 (Reinforced).**

- (1) **Height.** At least 18 in. measured vertically from existing ground to top of filter dam.
- (2) **Top Width.** At least 2 ft.
- (3) **Slopes.** At most 2:1.

- c. **Type 3 (Reinforced).**

- (1) **Height.** At least 36 in. measured vertically from existing ground to top of filter dam.
- (2) **Top Width.** At least 2 ft.
- (3) **Slopes.** At most 2:1.

- d. **Type 4 (Sack Gabions).** Unfold sack gabions and smooth out kinks and bends. For vertical filling, connect the sides by lacing in a single loop–double loop pattern on 4- to 5-in. spacing. At one end, pull the end lacing rod until tight, wrap around the end, and twist 4 times. At the filling end, fill with stone, pull the rod tight, cut the wire with approximately 6 in. remaining, and twist wires 4 times.

For horizontal filling, place sack flat in a filling trough, fill with stone, and connect sides and secure ends as described above.

506.4 to 506.4

Lift and place without damaging the gabion. Shape sack gabions to existing contours.

- e. **Type 5.** Provide rock filter dams as shown on the plans.
2. **Temporary Pipe Slope Drains.** Install pipe with a slope as shown on the plans or as directed. Construct embankment for the drainage system in 8-in. lifts to the required elevations. Hand-tamp the soil around and under the entrance section to the top of the embankment as shown on the plans or as directed. Form the top of the embankment or earth dike over the pipe slope drain at least 1 ft. higher than the top of the inlet pipe at all points. Secure the pipe with hold-downs or hold-down grommets spaced a maximum of 10 ft. on center. Construct the energy dissipators or sediment traps as shown on the plans or as directed. Construct the sediment trap using concrete or rubble riprap in accordance with Item 432, "Riprap," when designated on the plans.
3. **Baled Hay for Erosion and Sedimentation Control.** Install hay bales at locations shown on the plans by embedding in the soil at least 4 in. and, where possible, approximately 1/2 the height of the bale, or as directed. Fill gaps between bales with hay.
4. **Temporary Paved Flumes.** Construct paved flumes as shown on the plans or as directed. Provide excavation and embankment (including compaction of the subgrade) of material to the dimensions shown on the plans, unless otherwise indicated. Install a rock or rubble riprap energy dissipater, constructed from the materials specified above to a minimum depth of 9 in. at the flume outlet to the limits shown on the plans or as directed.
5. **Construction Exits.** When tracking conditions exist, prevent traffic from crossing or exiting the construction site or moving directly onto a public roadway, alley, sidewalk, parking area, or other right of way areas other than at the location of construction exits. Construct exits for either long or short-term use.
 - a. **Long-Term.** Place the exit over a foundation course, if necessary. Grade the foundation course or compacted subgrade to direct runoff from the construction exits to a sediment trap as shown on the plans or as directed. Construct exits with a width of at least 14 ft. for one-way and 20 ft. for two-way traffic for the full width of the exit, or as directed.
 - (1) **Type 1.** Construct to a depth of at least 8 in. using crushed aggregate as shown on the plans or as directed.

- (2) **Type 2.** Construct using railroad ties and timbers as shown on the plans or as directed.
- b. Short-Term.**
 - (1) **Type 3.** Construct using crushed aggregate, plywood, or wafer board. This type of exit may be used for daily operations where long-term exits are not practical.
 - (2) **Type 4.** Construct as shown on the plans or as directed.
- 6. Earthwork for Erosion Control.** Perform excavation and embankment operations to minimize erosion and to remove collected sediments from other erosion control devices.
 - a. Excavation and Embankment for Erosion Control Features.** Place earth dikes, swales, or combinations of both along the low crown of daily lift placement, or as directed, to prevent runoff spillover. Place swales and dikes at other locations as shown on the plans or as directed to prevent runoff spillover or to divert runoff. Construct cuts with the low end blocked with undisturbed earth to prevent erosion of hillsides. Construct sediment traps at drainage structures in conjunction with other erosion control measures as shown on the plans or as directed.

Where required, create a sediment basin providing 3,600 cu. ft. of storage per acre drained, or equivalent control measures for drainage locations that serve an area with 10 or more disturbed acres at one time, not including offsite areas.
 - b. Excavation of Sediment and Debris.** Remove sediment and debris when accumulation affects the performance of the devices, after a rain, and when directed.
- 7. Construction Perimeter Fence.** Construct, align, and locate fencing as shown on the plans or as directed.
 - a. Installation of Posts.** Embed posts 18 in. deep or adequately anchor in rock, with a spacing of 8 to 10 ft.
 - b. Wire Attachment.** Attach the top wire to the posts at least 3 ft. from the ground. Attach the lower wire midway between the ground and the top wire.
 - c. Flag Attachment.** Attach flagging to both wire strands midway between each post. Use flagging at least 18 in. long. Tie flagging to the wire using a square knot.

8. **Sandbags for Erosion Control.** Construct a berm or dam of sandbags that will intercept sediment-laden storm water runoff from disturbed areas, create a retention pond, detain sediment, and release water in sheet flow. Fill each bag with sand so that at least the top 6 in. of the bag is unfilled to allow for proper tying of the open end. Place the sandbags with their tied ends in the same direction. Offset subsequent rows of sandbags 1/2 the length of the preceding row. Place a single layer of sandbags downstream as a secondary debris trap. Place additional sandbags as necessary or as directed for supplementary support to berms or dams of sandbags or earth.
9. **Temporary Sediment-Control Fence.** Provide temporary sediment-control fence near the downstream perimeter of a disturbed area to intercept sediment from sheet flow. Incorporate the fence into erosion-control measures used to control sediment in areas of higher flow. Install the fence as shown on the plans, as specified in this Section, or as directed.
 - a. **Installation of Posts.** Embed posts at least 18 in. deep, or adequately anchor, if in rock, with a spacing of 6 to 8 ft. and install on a slight angle toward the run-off source.
 - b. **Fabric Anchoring.** Dig trenches along the uphill side of the fence to anchor 6 to 8 in. of fabric. Provide a minimum trench cross-section of 6 x 6 in. Place the fabric against the side of the trench and align approximately 2 in of fabric along the bottom in the upstream direction. Backfill the trench, then hand-tamp.
 - c. **Fabric and Net Reinforcement Attachment.** Unless otherwise shown under the plans, attach the reinforcement to wooden posts with staples, or to steel posts with T-clips, in at least 4 places equally spaced. Sewn vertical pockets may be used to attached reinforcement to end posts. Fasten the fabric to the top strand of reinforcement by hog rings or cord every 15 in. or less.
 - d. **Fabric and Net Splices.** Locate splices at a fence post with a minimum lap of 6 in. attached in at least 6 places equally spaced, unless otherwise shown under the plans. Do not locate splices in concentrated flow areas.

Requirements for installation of used temporary sediment-control fence include the following:

- fabric with minimal or no visible signs of biodegradation (weak fibers),
- fabric without excessive patching (more than 1 patch every 15 to 20 ft.),
- posts without bends, and
- backing without holes.

506.5. Measurement.

- A. Rock Filter Dams.** Installation or removal of rock filter dams will be measured by the foot or by the cubic yard. The measured volume will include sandbags, when used.
- 1. Linear Measurement.** When rock filter dams are measured by the foot, measurement will be along the centerline of the top of the dam.
 - 2. Volume Measurement.** When rock filter dams are measured by the cubic yard, measurement will be based on the volume of rock computed by the method of average end areas.
 - a. Installation.** Measurement will be made in final position.
 - b. Removal.** Measurement will be made at the point of removal.
- B. Temporary Pipe Slope Drains.** Temporary pipe slope drains will be measured by the foot.
- C. Baled Hay.** Baled hay will be measured by each bale.
- D. Temporary Paved Flumes.** Temporary paved flumes will be measured by the square yard of surface area. The measured area will include the energy dissipater at the flume outlet.
- E. Construction Exits.** Construction exits will be measured by the square yard of surface area.
- F. Earthwork for Erosion Control.**
- 1. Equipment.** Equipment use will be measured by the actual number of hours the equipment is operated.
 - 2. Volume Measurement.**
 - a. In Place.**
 - (1) Excavation.** Excavation will be measured by the cubic yard in its original position and the volume computed by the method of average end areas.
 - (2) Embankment.** Embankment will be measured by the cubic yard in its final position by the method of average

506.6 to 506.6

end areas. The volume of embankment will be determined between:

- the original ground surfaces or the surface upon that the embankment is to be constructed for the feature and
- the lines, grades and slopes of the accepted embankment for the feature.

- b. In Vehicles.** Excavation and embankment quantities will be combined and paid for under “Earthwork (Erosion and Sediment Control, In Vehicles).” Excavation will be measured by the cubic yard in vehicles at the point of removal. Embankment will be measured by the cubic yard in vehicles measured at the point of delivery. Shrinkage or swelling factors will not be considered in determining the calculated quantities.

G. Construction Perimeter Fence. Construction perimeter fence will be measured by the foot.

H. Sandbags for Erosion Control. Sandbags will be measured as each sandbag or by the foot along the top of sandbag berms or dams.

I. Temporary Sediment-Control Fence. Temporary sediment-control fence will be measured by the foot.

506.6. Payment. The following will not be paid for directly but are subsidiary to pertinent Items:

- erosion-control measures for Contractor project-specific locations (PSLs) inside and outside the right of way (such as construction and haul roads, field offices, equipment and supply areas, plants, and material sources);
- removal of litter;
- repair to devices and features damaged by Contractor operations;
- added measures and maintenance needed due to negligence, carelessness, lack of maintenance, and failure to install permanent controls;
- removal and reinstallation of devices and features needed for the convenience of the Contractor;
- finish grading and dressing upon removal of the device; and
- minor adjustments including but not limited to plumbing posts, reattaching fabric, minor grading to maintain slopes on an erosion embankment feature, or moving small numbers of sandbags.

The Contractor will be reimbursed in accordance with pertinent Items or Article 9.5, "Force Account," for maintenance, repair, or reinstallation of devices and features when the need for additional control measures cannot be attributed to the above, as determined by the Engineer. Stabilization of disturbed areas will be paid for under pertinent Items.

Furnishing and installing pipe for outfalls associated with sediment traps and ponds will not be paid for directly but is subsidiary to the excavation and embankment under this Item.

- A. Rock Filter Dams.** The work performed and materials furnished in accordance with this Item and measured as provided under "Measurement" will be paid for at the unit price bid as follows:
- 1. Installation.** Installation will be paid for as "Rock Filter Dams (Install)" of the type specified. This price is full compensation for furnishing and operating equipment, finish backfill and grading, lacing, proper disposal, labor, materials, tools, and incidentals.
 - 2. Removal.** Removal will be paid for as "Rock Filter Dams (Remove)." This price is full compensation for furnishing and operating equipment, proper disposal, labor, materials, tools, and incidentals.

When the Engineer directs that the rock filter dam installation or portions thereof be replaced, payment will be made at the unit price bid for "Rock Filter Dams (Remove)" and for "Rock Filter Dams (Install)" of the type specified. This price is full compensation for furnishing and operating equipment, finish backfill and grading, lacing, proper disposal, labor, materials, tools, and incidentals

- B. Temporary Pipe Slope Drains.** The work performed and materials furnished in accordance with this Item and measured as provided under "Measurement" will be paid for at the unit price bid for "Temporary Pipe Slope Drains" of the size specified. This price is full compensation for furnishing materials, removal and disposal, furnishing and operating equipment, labor, tools, and incidentals.

Removal of temporary pipe slope drains will not be paid for directly but is subsidiary to the installation Item. When the Engineer directs that the pipe slope drain installation or portions thereof be replaced, payment will be made at the unit price bid for "Temporary Pipe Slope Drains" of the size specified, which is full compensation for the removal and reinstallation of the pipe drain.

506.6 to 506.6

Earthwork required for the pipe slope drain installation, including construction of the sediment trap, will be measured and paid for under Section 506.5.F, "Earthwork for Erosion and Sediment Control."

Riprap concrete or stone, when used as an energy dissipater or as a stabilized sediment trap, will be measured and paid for in accordance with Item 432, "Riprap."

- C. Baled Hay.** The work performed and materials furnished in accordance with this Item and measured as provided under "Measurement" will be paid for at the unit price bid for "Baled Hay." This price is full compensation for furnishing and placing bales, excavating trenches, removal and disposal, equipment, labor, tools, and incidentals.

When the Engineer directs that the baled hay installation (or portions thereof) be replaced, payment will be made at the unit price bid for "Baled Hay," which is full compensation for removal and reinstallation of the baled hay.

- D. Temporary Paved Flumes.** The work performed and materials furnished in accordance with this Item and measured as provided under "Measurement" will be paid for at the unit price bid for "Temporary Paved Flume (Install)" or "Temporary Paved Flume (Remove)." This price is full compensation for furnishing and placing materials, removal and disposal, equipment, labor, tools, and incidentals.

When the Engineer directs that the paved flume installation or portions thereof be replaced, payment will be made at the unit prices bid for "Temporary Paved Flume (Remove)" and "Temporary Paved Flume (Install)." These prices are full compensation for the removal and replacement of the paved flume and for equipment, labor, tools, and incidentals.

Earthwork required for the paved flume installation, including construction of a sediment trap, will be measured and paid for under Section 506.5.F, "Earthwork for Erosion and Sediment Control."

- E. Construction Exits.** Contractor-required construction exits from off-right of way locations or on-right of way PSLs will not be paid for directly but are subsidiary to pertinent Items.

The work performed and materials furnished in accordance with this Item and measured as provided under "Measurement" for construction exits needed on right of way access to work areas required by the Department will be paid for at the unit price bid for "Construction Exits (Install)" of the type specified or "Construction Exits (Remove)." This price is full compensation for furnishing and placing materials,

excavating, removal and disposal, cleaning vehicles, labor, tools, and incidentals.

When the Engineer directs that a construction exit or portion thereof be removed and replaced, payment will be made at the unit prices bid for "Construction Exit (Remove)" and "Construction Exit (Install)" of the type specified. These prices are full compensation for the removal and replacement of the construction exit and for equipment, labor, tools, and incidentals.

Construction of sediment traps used in conjunction with the construction exit will be measured and paid for under Section 506.5.F, "Earthwork for Erosion and Sediment Control."

- F. Earthwork for Erosion and Sediment Control.** The work performed and materials furnished in accordance with this Item and measured as provided under "Measurement" will be paid for at the unit price bid for "Excavation (Erosion and Sediment Control, In Place)," "Embankment (Erosion and Sediment Control, In Place)," "Earthwork (Erosion and Sediment Control, In Vehicles)," "Dragline Work (Erosion and Sediment Control)," "Backhoe Work (Erosion and Sediment Control)," "Excavator Work (Erosion and Sediment Control)," "Front End Loader Work (Erosion and Sediment Control)," "Blading Work (Erosion and Sediment Control)," "Scraper Work (Erosion and Sediment Control)," or "Bulldozer Work (Erosion and Sediment Control)."

This price is full compensation for excavation including removal of accumulated sediment in various erosion control installations as directed, hauling, and disposal of material not used elsewhere on the project; excavation for construction of erosion-control features; embankments including furnishing material from approved sources and construction of erosion-control features; sandbags; plywood; stage construction for curb inlets involved in curb-inlet sediment traps; and equipment, labor; tools, and incidentals.

Earthwork needed to remove and obliterate of erosion-control features will not be paid for directly but is subsidiary to pertinent Items unless otherwise shown on the plans.

Sprinkling and rolling required by this Item will not be paid for directly, but will be subsidiary to this Item.

- G. Construction Perimeter Fence.** The work performed and materials furnished in accordance with this Item and measured as provided under "Measurement" will be paid for at the unit price bid for "Construction Perimeter Fence." This price is full compensation for furnishing and

508.1 to 508.1

placing the fence; digging, fence posts, wire, and flagging; removal and disposal; and materials, equipment, labor, tools, and incidentals.

Removal of construction perimeter fence will not be paid for directly but is subsidiary to the installation Item. When the Engineer directs that the perimeter fence installation or portions thereof be removed and replaced, payment will be made at the unit price bid for "Construction Perimeter Fence," which is full compensation for the removal and reinstallation of the construction perimeter fence.

- H. Sandbags for Erosion Control.** Sandbags will be paid for at the unit price bid for "Sandbags for Erosion Control" (of the height specified when measurement is by the foot). This price is full compensation for materials, placing sandbags, removal and disposal, equipment, labor, tools, and incidentals.

Removal of sandbags will not be paid for directly but is subsidiary to the installation Item. When the Engineer directs that the sandbag installation or portions thereof be replaced, payment will be made at the unit price bid for "Sandbags for Erosion Control," which is full compensation for the reinstallation of the sandbags.

- I. Temporary Sediment-Control Fence.** The work performed and materials furnished in accordance with this Item and measured as provided under "Measurement" will be paid for at the unit price bid for "Temporary Sediment-Control Fence." This price is full compensation for furnishing and placing the fence; trenching, fence posts, fabric and backfill; removal and disposal; and equipment, labor, tools, and incidentals.

Removal of temporary sediment-control fence will not be paid for directly but is subsidiary to the installation Item. When the Engineer directs that the temporary sedimentation control fence installation or portions thereof be replaced, payment will be made at the unit price bid for "Temporary Sediment-Control Fence," which is full compensation for the removal and reinstallation of the temporary sediment-control fence.

ITEM 508

CONSTRUCTING DETOURS

508.1. Description. Construct and maintain detours. Remove detours when required.

508.2. Materials.

A. Embankment. Use roadway excavation for embankment material or use material from other approved sources.

B. Temporary Drainage Pipe. Furnish pipe required for temporary drainage in accordance with details shown on the plans or as directed. Pipe will become the property of the Contractor upon removal.

Temporary use of permanent pipe for use on the project is allowable if the sequence of work permits. If pipe used temporarily is damaged so that it is not acceptable in accordance with applicable Items, it will not be acceptable for incorporation in the final project. The damaged pipe remains the property of the Contractor.

C. Base and Surfacing. Furnish base and surfacing materials in accordance with Items as shown on the plans.

508.3. Construction. Construct the detour at the locations and to the lines, grades, and typical sections shown on the plans or as directed, in accordance with pertinent Items. Maintain detours for public travel in a safe and passable condition. The safety of the public and convenience of traffic is of prime importance. Maintain detours in accordance with Article 4.5, "Maintenance of Traffic"; Article 7.7, "Public Safety and Convenience"; Article 7.14, "Contractor's Responsibility for Work"; and this Item.

Remove detours after they are no longer needed for traffic. Removed materials will become the property of the Contractor unless otherwise shown on the plans or directed. Dispose of the materials off the right of way, unless otherwise directed, in accordance with federal, state, and local requirements. If allowed, materials may be disposed of by spreading along the adjacent roadway slopes. If embankment, base, or surfacing is to be reused within the roadway construction or stockpiled for future use, salvage or stockpile in accordance with pertinent Items.

508.4. Measurement. This Item will be measured by the 100-ft. station, the square yard of pavement area, or each detour constructed.

508.5. Payment. The work performed and materials furnished in accordance with this Item and measured as provided under "Measurement" will be paid for at the unit bid price for "Constructing Detours," or for "Constructing Detours (EBSS)." EBSS (Embankment Base Surface Separate) is used when embankment, base, and surface are paid for separately.

510.1 to 510.3

The price bid for “Constructing Detours” is full compensation for furnishing all materials required, including embankment, base, and surfacing; excavation and hauling of excavated material; sprinkling and compacting; furnishing, installing, and removing drainage structures; removal of detour; disposal of materials; and equipment, labor, tools, and incidentals.

The price bid for “Construction Detours (EBSS)” is full compensation for furnishing, installing, and removing drainage structures; removal of detour; disposal of materials; and equipment, labor, tools, and incidentals, except that embankment, flexible base, and surfacing will be measured and paid for in accordance with other pertinent Items.

Maintenance of detours constructed will not be paid for directly but will be subsidiary to this Item. Maintenance of pavement on detours that use existing pavement will be paid for in accordance with Article 7.14, “Contractor’s Responsibility for Work.”

When the plans require the base and surfacing to be removed and incorporated in the final roadway or stockpiled after use on the detour, the work will be performed, measured, and paid for in accordance with the pertinent Items shown for salvaging, replacing, or stockpiling materials.

All other items not specifically addressed in this Article will be paid for under pertinent Items, unless otherwise shown on the plans.

ITEM 510

ONE-WAY TRAFFIC CONTROL

510.1. Description. Provide one-way traffic control.

510.2. Work Methods. Furnish flaggers in accordance with the requirements of Item 502, “Barricades, Signs, and Traffic Handling,” at all entry points to the work zone, to stop traffic. Furnish a Stop–Slow paddle for each flagger and a pilot vehicle with required signs attached. Provide paddles and signs that meet the requirements of the TMUTCD. Furnish a licensed driver for the pilot vehicle. Instruct drivers to follow the pilot vehicle and to not pass the cars ahead.

510.3. Measurement. When shown on the plans as a bid item, this Item will be measured by the actual number of hours of use for the combination of flaggers and pilot vehicle.

510.4. Payment. Unless otherwise shown on the plans, the work performed and materials furnished in accordance with this Item will not be paid for directly but will be subsidiary to pertinent Items.

When shown on the plans as a bid item, the work performed and materials furnished in accordance with this Item and measured as provided under “Measurement” will be paid for at the unit price bid for “One-Way Traffic Control.” This price is full compensation for furnishing and operating equipment, pilot vehicle driver, flaggers, signs, labor, tools, and incidentals.

ITEM 512

PORTABLE CONCRETE TRAFFIC BARRIER

512.1. Description. Furnish, install, move, and remove portable precast concrete traffic barrier.

512.2. Materials. Barrier sections will be furnished by the Department when shown on the plans. Furnish new barrier using materials that meet the pertinent requirements of the following Items:

- Item 421, “Hydraulic Cement Concrete”
- Item 440, “Reinforcing Steel”
- Item 442, “Metal for Structures.”

When temporary barrier is to be furnished and retained by the Contractor, products from nonapproved sources or previously used product may be provided if the Contractor submits written certification that the barrier sections and materials substantially conform to the requirements of this Item. The Engineer may approve the use of the product if:

- the barrier sections substantially meet typical cross-sectional dimension requirements,
- there is no evidence of structural damage such as major spalling or cracking, and
- the general condition of both the barrier sections and their connectors is acceptable.

Barrier sections to be furnished by the Department will be at a stockpile location or existing concrete traffic barrier installation shown on the plans.

512.3. Construction. Notify the Engineer of the location of the casting site and the date on which the work will begin. Multi-project fabrication plants (as defined in Item 424, “Precast Concrete Structures (Fabrication)”) that produce concrete traffic barrier must be approved in accordance with DMS-7350, “Qualification Procedure for Multi-Project Fabrication Plants

512.3 to 512.4

of Precast Concrete Traffic Barrier.” The Construction Division maintains a list of approved multi-project plants. Construct barrier in accordance with Item 420, “Concrete Structures,” to the dimensions and cross-sections shown on the plans. Provide forms and cure concrete in accordance with Item 424, “Precast Concrete Structures (Fabrication).”

Provide a rough texture to the bottom surface of Single Slope, F Shape, or Safety Shape barriers and to the top of Low Profile barriers similar to a wood float finish.

Remove formwork after the concrete has reached sufficient strength to prevent physical damage to the member. When the barrier sections have attained sufficient strength to permit handling without causing visible damage, move the barrier sections to a storage area and place them on blocking to prevent damage.

Produce precast barrier to the tolerances given in Table 1 unless otherwise shown on the plans.

Table 1
Precast Barrier Tolerances

Dimension	Tolerance
Length	±1"
Insert Placement	±1/2"
Horizontal Alignment	±1/8" per 10 ft. of length
Deviation of Ends:	
Horizontal Skew	±1/4"
Vertical Batter	±1/8" per foot of depth

Install the barrier sections in accordance with the details shown on the plans or as directed.

Stockpile portable barriers no longer required on the project and to be retained by the Department, not designated for permanent use, at a site shown on the plans or as directed. Haul Department-owned connection hardware after use to the Department warehouse nearest the project unless otherwise shown on the plans or as directed.

Repair or replace all concrete traffic barrier or connecting hardware damaged by the Contractor’s operations at the Contractor’s expense.

Repair or replace any pavement damaged in the process of installing, moving, or removing barrier at the Contractor’s expense.

512.4. Measurement. This Item will be measured by the foot based on the nominal lengths of the barrier sections.

512.5. Payment. The work performed and materials furnished in accordance with this Item and measured as provided under “Measurement” will be paid for at the unit price bid for “Portable Concrete Traffic Barrier” of the work category (Furnish and Install, Designated Source, Move, Stockpile, or Remove), shape (e.g., Safety Shape, Single Slope, F Shape, or Low Profile) and type (1, 2, 3, etc.) of barrier specified. This price includes equipment, labor, tools, and incidentals.

- A. Furnish and Install.** This price is full compensation for furnishing and installing barrier and connection hardware.
- B. Designated Source.** This price is full compensation for delivering and installing Department-furnished barrier and connection hardware from a designated source.
- C. Move.** This price is full compensation for moving barrier installations on the project from one location to another (including disassembly and reassembly costs), moving barrier from an installation on the project to a temporary storage area (including disassembly costs), and moving barrier from a temporary storage area to an installation site on the project (including assembly costs).
- D. Stockpile.** This price is full compensation for removing barrier and connection hardware from the project and delivering to the Department stockpile area shown on the plans or as directed.
- E. Remove.** This price is full compensation for removing barrier and connection hardware from the project and retained by the Contractor.

ITEM 514

PERMANENT CONCRETE TRAFFIC BARRIER

514.1. Description. Construct permanent concrete traffic barrier.

514.2. Materials. Furnish new barrier using materials that meet the pertinent requirements of the following Items:

- Item 420, “Concrete Structures”
- Item 421, “Hydraulic Cement Concrete”
- Item 440, “Reinforcing Steel”
- Item 442, “Metal for Structures.”

Furnish the class of concrete shown on the plans.

514.3 to 514.3

514.3. Construction.

- A. General.** Perform excavation and embankment work in accordance with Item 400, "Excavation and Backfill for Structures," except for measurement and payment.

Place reinforcing steel in accordance with Item 440, "Reinforcing Steel." Welding of additional bars to the reinforcing cage is allowable, if approved, when slipform placement is used. Weld in accordance with Item 448, "Structural Field Welding."

Unless otherwise shown on the plans, cast barrier in place, slipform barrier, or construct barrier using precast concrete sections. Use forms meeting the requirements of Item 424, "Precast Concrete Structures (Fabrication)" for precast sections. Wood forms are allowable for curves and transitions. Construct formwork in accordance with Item 420, "Concrete Structures."

Multi-project fabrication plants (as defined in Item 424, "Precast Concrete Structures (Fabrication)") that produce concrete traffic barrier must be approved in accordance with DMS-7350, "Qualification Procedure for Multi-Project Fabrication Plants of Precast Concrete Traffic Barrier." The Construction Division maintains a list of approved multi-project plants. When required, construct drilled shaft foundations in accordance with Item 416, "Drilled Shaft Foundations."

Construct barrier in accordance with Item 420, "Concrete Structures." Form-cure or water-cure concrete, except for precast sections, for at least 4 days, or cure with Type 1-D or Type 2 membrane curing compound. Cure precast sections in accordance with Item 424, "Precast Concrete Structures (Fabrication)."

Remove concrete, mortar, oil, and other substances leaked onto the roadway.

B. Cast-in-Place Barrier.

- 1. Conventionally Formed Barrier.** Accurately set forms for conventionally formed barrier. Secure the forms in a manner that is not detrimental to roadway pavement and maintain barrier in a true position during concrete placement. Remove forms after the concrete has reached sufficient strength to prevent physical damage to the barrier.
- 2. Slipformed Barrier.** Slipformed barriers must be within a vertical and horizontal alignment tolerance of $\pm 1/4$ in. in 10 ft. Construct barrier with a smooth and uniform appearance. Remove and replace unsatisfactory barrier at the Contractor's expense.

Consolidate concrete so it is free of honeycomb. Provide concrete with a consistency that will maintain the shape of the barrier without support. Minimize starting and stopping of the slipform operation by ensuring a continuous supply of concrete. Provide a wire line to maintain vertical and horizontal alignment of the slipform machine. Attach a grade line gauge or pointer to the machine so a continuous comparison can be made between the barrier being placed and the established grade line. Do not exceed the manufacturer's recommended speed for the slipform machine. Rails or supports at the required grade are allowed instead of sensor controls.

- C. Precast Sections.** If precast sections are to be used, notify the Engineer of the location of the casting site and date on which work will begin. Form-cure concrete until the concrete has reached sufficient strength to permit handling without visible cracks or other damage to the sections. Produce precast barrier sections to the tolerances of Table 1 unless otherwise shown on the plans.

Table 1
Precast Barrier Tolerances

Dimension	Tolerance
Length	±1"
Insert Placement	±1/2"
Horizontal Alignment	±1/8" per 10 ft. of length
Deviation of Ends:	
Horizontal Skew	±1/4"
Vertical Batter	±1/8" per foot of depth

Repair or replace concrete traffic barrier damaged in the process of fabricating, curing, handling or placing, as directed.

514.4. Measurement. This Item, including terminal sections, will be measured by the foot. Barriers with two longitudinal half-sections will be measured once along the centerline between the two halves.

514.5. Payment. The work performed and materials furnished in accordance with this Item and measured as provided under "Measurement" will be paid for at the unit price bid for "Permanent Concrete Traffic Barrier" of the shape (e.g. Safety Shape, Single Slope, or "F" Shape), type (1, 2, 3, etc.), and height (for Single Slope) specified. This price is full compensation for furnishing and placing materials, including footings and

514.5 to 520.2

drilled-shaft foundations; and excavation and embankment, equipment, labor, tools, and incidentals.

Unless shown on the plans as a bid item, asphalt concrete pavement used for lateral support will not be paid for directly but will be subsidiary to this Item.

ITEM 520

WEIGHING AND MEASURING EQUIPMENT

520.1. Description. Provide weighing and measuring equipment for materials measured or proportioned by weight or volume.

520.2. Equipment. Provide certified scales, scale installations, and measuring equipment meeting the requirements of NIST Handbook 44, except that the required accuracy must be 0.4% of the material being weighed or measured.

Provide personnel, facilities, and equipment for checking the scales to the satisfaction of the Engineer. Check all weighing and measuring equipment after each move and at least once each 6 mo. or when requested.

Calibrate all scales using weights certified by the TDA or an equivalent agency approved by the Engineer. Provide a written calibration report from a scale mechanic for all calibrations. Cease plant operations during the checking operation. Do not use inaccurate or inadequate scales. When adjusting equipment, bring performance errors as close as practicable to zero.

Furnish sufficient certified weights to check the accuracy and sensitivity of the scales. Insulate scales against shock, vibrations, or movement of other operating equipment. On a daily basis, provide an automated ticket printout for each truckload of material where payment is determined by weight. Each loading ticket must show the ticket number, truck number, gross weight, tare weight, and net weight.

If required on the plans for materials paid for by the ton, provide a summary spreadsheet that lists separately the ticket number, truck number, gross weight, tare weight, net weight, overload weight, and payment weight amounts as shown in Table 1. Provide this spreadsheet:

- for each lot when materials are paid for in increments of sublots or lots and
- daily for other materials.

For all summary sheets, within 2 days of delivery of materials, provide the totals for net weight and overload amounts to be deducted. Include the overload deduction in the total amount reported for payment. Submissions are subject to verification by the Engineer.

Table 1
Example Spreadsheet

Ticket No.	Truck No.	Gross Wt.	Tare Wt.	Net Wt.	Overload Wt.	Payment Wt.
				Totals	Totals	Totals

Furnish leak-free weighing containers large enough to hold a complete batch of the material being measured.

- A. Truck Scales.** Furnish platform truck scales capable of weighing the entire truck or truck-trailer combination in a single draft.
- B. Aggregate Batching Scales.** Equip scales used for weighing aggregate with a quick adjustment at zero that provides for any change in tare. Provide a visual means that indicates the required weight for each aggregate.
- C. Suspended Hopper.** Provide a means for the addition or the removal of small amounts of material to adjust the quantity to the exact weight per batch. Ensure the scale equipment is level.
- D. Belt Scales.** Use belt scales for proportioning aggregate that are accurate to within 1.0% based on the average of 3 test runs, where no individual test run exceeds 2.0% when checked in accordance with Tex-920-K.
- E. Asphalt Material Meter.** Provide an asphalt material meter with an automatic digital display of the volume or weight of asphalt material. Verify the accuracy of the meter in accordance with Tex-921-K. When using the asphalt meter for payment purposes, ensure the accuracy of the meter is within 0.4%. When used to measure component materials only and not for payment, ensure the accuracy of the meter is within 1.0%.
- F. Liquid Asphalt Additive Meters.** Provide a means to check the accuracy of meter output for asphalt primer, fluxing material, and liquid additives. Furnish a meter that reads in increments of 0.1 gal. or less. Verify accuracy of the meter in accordance with Tex-923-K. Ensure the accuracy of the meter within 5.0%.

520.3 to 528.2

G. Particulate Solid and Slurry Additive Meters. Provide a means to check the accuracy of meter output for particulate solids (such as hydrated lime or mineral filler) and slurries (such as hydrated lime slurry). Ensure the accuracy of the meter within 5.0%.

520.3. Measurement and Payment. The work performed, materials furnished, equipment, labor, tools, and incidentals will not be measured or paid for directly, but will be subsidiary to pertinent Items.

ITEM 528

COLORED TEXTURED CONCRETE AND LANDSCAPE PAVERS

528.1. Description.

- A. Colored Textured Concrete.** Furnish and place colored textured concrete.
- B. Landscape Pavers.** Furnish and install landscape pavers.

528.2. Materials.

- A. Colored Textured Concrete.** Furnish materials in accordance with the following:
 - Item 420, “Concrete Structures”
 - Item 421, “Hydraulic Cement Concrete”
 - Item 440, “Reinforcing Steel.”

Use Type 1 cement of the same brand and source throughout the structure. Use coarse aggregate consisting of natural or crushed gravel and fine aggregate consisting of natural or manufactured particles conforming to Item 421, “Hydraulic Cement Concrete,” unless otherwise shown on the plans. Provide materials meeting gradation shown on the plans. Use Class A concrete unless otherwise shown on the plans.

Use approved dry-shake color hardener or integral concrete colorant shown on the plans. Provide colored wax as a curing membrane meeting the requirements of ASTM C 309 or as shown on the plans.

- B. Landscape Pavers.** Furnish materials in accordance with:
 - 1. Embankment.** Furnish embankment in accordance with Item 132, “Embankment.”

2. **Base.** Furnish base in accordance with details shown on the plans. Provide flexible base, when required, in accordance with Item 247, "Flexible Base."
3. **Pavers.** Furnish pavers meeting the requirements of ASTM C 936; made using normal-weight aggregates conforming to ASTM C 33; and conforming to the shape, color, laying pattern, and dimensions shown on the plans. Furnish certification from the manufacturer stating that the interlocking paving units have been tested and meet all the requirements of ASTM C 936. Furnish additional paving units when required for testing by the Department.
4. **Bedding Sand.** Furnish fine aggregate as specified in Item 421, "Hydraulic Cement Concrete," with the gradation given in Table 1.

Table 1
Bedding Sand Gradation

Sieve Size	Percent Passing
3/8"	100
No. 4	85–100
No. 100	10–30

Spread the sand at a uniform moisture content of 3% to 7%. Protect the sand against rain if it is stockpiled on-site before spreading.

5. **Joint-Filling Sand.** Meet the requirements for bedding sand, except with the gradation given in Table 2.

Table 2
Joint-filling Sand Gradation

Sieve Size	Percent Passing
No. 4	100
No. 8	90–100
No. 16	60–100
No. 30	25–70
No. 50	10–30
No. 100	2–15
No. 200	Less than 10

528.3. Construction Methods.

- A. Colored Textured Concrete.** Prepare for approval a 9-sq. ft., 3-in.-thick specimen for each color, pattern, and texture required before beginning work.

Prepare the subgrade, base, or both in accordance with the plans and pertinent Items. Place and screed concrete to the proper grade and wood-float to a uniform surface, in accordance with Item 420, "Concrete Structures."

Apply colorant in accordance with the manufacturer's recommendations. Apply dry-shake color hardener, if used, evenly to the plastic surface, following the manufacturer's directions. Use at least 65 lb. per 12 sq. yd. Apply in 2 separate applications and wood-float after each application. Trowel only after the final floating.

Place dies with a repetitive pattern on the concrete surface and hand-tamp to create the required texture or imprint shown on the plans. Apply colored curing and finishing compound in accordance with the manufacturer's directions.

B. Landscape Pavers.

- 1. Base Installation.** Perform excavation and embankment work for the subgrade. Replace unsuitable material encountered in the subgrade and compact to a uniform grade. Stabilize subgrade if specified. Place and compact the base to ordinary compaction requirements in accordance with the pertinent Item, and to the depth specified on the plans. Grade the base surface so that the finished grade of the pavers meets the requirements shown on the plans.

- 2. Bedding Sand Installation.** Screed a layer of uncompacted sand to a depth of 1 in. to 1-1/2 in. over the compacted base. Do not use bedding sand for leveling.

Maintain the spread sand in a loose condition and protect against precompaction before and after screeding. Protect screeded sand against accidental precompaction, including compaction by rain or dew. Loosen precompacted sand or screeded sand in advance of the laying face only to an extent to which paving will be completed that day. Lightly screed the sand in a loose condition to the predetermined depth slightly ahead of laying the paving units.

- 3. Paver Installation.** Place paving units on an uncompacted, screeded sand bed to the required laying pattern shown on the

plans. Align all joints and provide nominal 1/8-in. gaps between adjacent units.

Place the first row to abut an edge restraint with a gap of 1/8 in. Place at a suitable angle to the edge restraint to achieve the required visual orientation of paving units in the completed pavement. In each row, lay full-size units first followed by closure units consisting of at least 25% of a full unit. Cut units using a power saw. To fill smaller edge spaces, use a grout mix matching the color of the pavers that consists of 1 part hydraulic cement to 2 parts concrete sand. Use cement and sand that meet Item 421, "Hydraulic Cement Concrete."

Do not allow construction traffic on pavers during installation and compaction.

4. **Paver Compaction.** Provide a high-frequency, low-amplitude mechanical flat plate vibrator compactor with a plate area large enough to cover at least 12 paving units and that can deliver a 3,500- to 5,000-lb. centrifugal compaction force. Compact paving units immediately after placement to achieve consolidation of the sand bedding before any traffic is allowed. Bring to design levels and profiles by at least 2 passes of the plate compactor.

Do not compact within 3 ft. of the laying face. Continue compaction until lipping has been eliminated between the adjoining units. Compact all work to within 3 ft. of the laying face at the completion of each work day.

Spread joint-filling sand as soon as practical after compaction but in all cases before the termination of each work day, before acceptance of the day's work, and before permitting construction traffic. Allow joint-filling sand to dry, and then sweep to fill the joints. Compact the pavers and joint-filling sand with a single pass of the compactor.

528.4. Measurement. This Item will be measured by the square yard.

528.5. Payment. Excavation and embankment will not be paid for directly but will be subsidiary to this Item, unless otherwise shown on the plans.

- A. **Colored Textured Concrete.** The work performed and measured as provided under "Measurement" will be paid for at the unit price bid for "Colored Textured Concrete" of the thickness specified. This price is full compensation for surface preparation of subgrade and base;

529.1 to 529.3

furnishing, placing, finishing, and curing colored-textured concrete; and equipment, labor, materials, tools, and incidentals.

Preparation of approval specimens will not be paid for directly, but will be considered subsidiary to this Item. Base under colored textured concrete will be paid for under pertinent Items unless otherwise shown on the plans.

- B. Landscape Pavers.** The work performed and measured as provided under “Measurement” will be paid for at the unit price bid for “Landscape Pavers.” This price is full compensation for furnishing, placing, and compacting pavers; bedding and joint-filling sand; and equipment, labor, materials, tools, and incidentals. Paver units damaged during compaction will be replaced at the Contractor’s expense. Base required for landscape pavers will not be paid for directly but will be subsidiary to this Item.

ITEM 529 CONCRETE CURB, GUTTER, AND COMBINED CURB AND GUTTER

529.1. Description. Construct hydraulic cement concrete curb, gutter, and combined curb and gutter.

529.2. Materials. Furnish materials conforming to:

- Item 360, “Concrete Pavement”
- Item 420, “Concrete Structures”
- Item 421, “Hydraulic Cement Concrete”
- Item 440, “Reinforcing Steel.”

Use Class A concrete or material specified in the plans. Use Grade 8 coarse aggregate for extruded Class A concrete. Use other grades if approved by the Engineer.

529.3. Construction. Provide finished work with a well-compacted mass and a surface free from voids and honeycomb, in the required shape, line, and grade. Round exposed edges with an edging tool of the radius shown on the plans. Mix, place, and cure concrete in accordance with Item 420, “Concrete Structures.” Construct joints at locations shown on the plans. Cure for at least 72 hr.

Furnish and place reinforcing steel in accordance with Item 440, “Reinforcing Steel.”

Set and maintain a guideline that conforms to alignment data shown on the plans, with an outline that conforms to the details shown on the plans.

- A. Conventionally Formed Concrete.** Shape and compact subgrade, foundation, or pavement surface to the line, grade, and cross section shown on the plans. Lightly sprinkle subgrade or foundation material immediately before concrete placement.

Pour concrete into forms, and strike off with a template 1/4 to 3/8 in. less than the dimensions of the finished curb unless otherwise approved. After initial set, plaster surface with mortar consisting of 1 part hydraulic cement and 2 parts fine aggregate. Brush exposed surfaces to a uniform texture.

Place curbs, gutters, and combined curb and gutters in 50-ft. maximum sections unless otherwise approved.

- B. Extruded or Slipformed Concrete.** Hand-tamp and sprinkle subgrade or foundation material before concrete placement. Provide clean surfaces for concrete placement. If required, coat cleaned surfaces with approved adhesive or coating at the rate of application shown on the plans or as directed. Place concrete with approved self-propelled equipment.

The forming tube of the extrusion machine or the form of the slipform machine must be easily adjustable vertically during the forward motion of the machine to provide variable heights necessary to conform to the established gradeline.

Attach a pointer or gauge to the machine so that a continual comparison can be made between the extruded or slipform work and the grade guideline. Other methods may be used when approved.

Finish surfaces immediately after extrusion or slipforming.

529.4. Measurement. This Item will be measured by the foot.

529.5. Payment. The work performed and materials furnished in accordance with this Item and measured as provided under "Measurement" will be paid for at the unit price bid for "Concrete Curb," "Concrete Curb (Mono)," or "Concrete Curb and Gutter" of the type specified. This price is full compensation for surface preparation of base, equipment, labor, materials, tools, and incidentals.

530.1 to 530.4

ITEM 530

INTERSECTIONS, DRIVEWAYS, AND TURNOUTS

530.1. Description. Construct and pave intersections, driveways, and turnouts. Pave existing intersections, driveways, and turnouts.

Intersections are considered to be areas off the travel lanes and shoulders of the Contract highway on the intersecting highway on the state system. The intersecting on-system highway work will be paid for under this Item only when shown on the plans.

Driveways are defined as private (residential or commercial) and public (county road and city street) access areas off the travel lanes and shoulders.

Turnouts include but are not limited to mailbox and litter barrel widenings.

530.2. Materials. Furnish materials that meet the following:

- Item 247, “Flexible Base”
- Item 260, “Lime Treatment (Road Mixed)”
- Item 263, “Lime Treatment (Plant Mixed)”
- Item 275, “Cement Treatment (Road Mixed)”
- Item 276, “Cement Treatment (Plant Mixed)”
- Item 292, “Asphalt Treatment (Plant Mix)”
- Item 316, “Surface Treatments”
- Item 330, “Limestone Rock Asphalt Pavement”
- Item 334, “Hot Mix–Cold Laid Asphalt Concrete Pavement”
- Item 340, “Dense-Graded Hot Mix Asphalt Concrete Pavement (Method)”
- Item 360, “Concrete Pavement”
- Item 421, “Hydraulic Cement Concrete”
- Item 440, “Reinforcing Steel.”

530.3. Construction. Construct and pave intersections, driveways, and turnouts, and pave existing intersections, driveways, and turnouts as shown on the plans or as directed. Place materials in accordance with construction Articles of pertinent Items. Provide uninterrupted access to adjacent property unless otherwise directed. Ensure that abrupt elevation changes in driveway or turnout areas that serve as sidewalks do not exceed 1/4 in. and that the sidewalk area cross slope does not exceed 2%. Ready-mix concrete and hand finishing will be permitted when concrete pavement is specified unless otherwise shown in the plans for intersections.

530.4. Measurement. This Item will be measured by each intersection, driveway, or turnout, or by the square yard of the final pavement surface.

When “Intersections, Driveways, and Turnouts” or “Driveways and Turnouts” are bid, measurement will be restricted to the square yard.

530.5. Payment. The work performed and materials furnished in accordance with this Item and measured as provided under “Measurement” will be paid for at the unit price bid for “Intersections,” “Driveways,” “Turnouts,” “Intersections, Driveways, and Turnouts,” or “Driveways and Turnouts” of the surface specified (Concrete, Asphaltic Concrete Pavement, or Surface Treatment).

This price is full compensation for furnishing and operating equipment; excavation and embankment; base and pavement materials; and labor, materials, tools, and incidentals. Drainage structures will be measured and paid for in accordance with the pertinent bid Items. Bonus and penalties for quality control and quality assurance (QC/QA) materials will not apply when payment for those materials is made under this Item.

ITEM 531 SIDEWALKS

531.1. Description. Construct hydraulic cement concrete sidewalks.

531.2. Materials. Furnish materials conforming to the following:

- Item 360, “Concrete Pavement”
- Item 420, “Concrete Structures”
- Item 421, “Hydraulic Cement Concrete”
- Item 440, “Reinforcing Steel.”

Use Class A concrete or other concrete as specified. Use Grade 8 course aggregate for extruded Class A concrete. Use other grades if approved by the Engineer.

531.3. Construction. Shape and compact subgrade, foundation, or pavement surface to the line, grade, and cross-section shown on the plans. Lightly sprinkle subgrade or foundation material immediately before concrete placement. Hand-tamp and sprinkle foundation when placement is directly on subgrade or foundation materials. Remove and dispose of existing concrete in accordance with Item 104, “Removing Concrete.” Provide a clean surface for concrete placement directly on the surface material or pavement.

Mix and place concrete in accordance with the pertinent Items. Hand-finishing is allowed for any method of construction. Finish exposed surfaces

531.4 to 531.5

to a uniform transverse broom finish surface. Curb ramps must include a detectable warning surface and conform to details shown on the plans. Install joints as shown on the plans. Brush all exposed surfaces to a smooth and uniform surface. Ensure that abrupt changes in sidewalk elevation do not exceed 1/4 inch, sidewalk cross slope does not exceed 2%, curb ramp grade does not exceed 8.3%, and flares adjacent to the ramp do not exceed 10% slope. Where a sidewalk crosses a concrete driveway, ensure that the sidewalk depth and reinforcement are not less than the driveway cross-sectional details shown on the plans.

Provide finished work with a well-compacted mass, a surface free from voids and honeycomb, and the required true-to-line shape and grade. Cure for at least 72 hr. in accordance with Item 420, "Concrete Structures."

- A. Conventionally Formed Concrete.** Provide sidewalk sections separated by premold or board joint of the thickness shown on the plans in lengths greater than 8 ft. but less than 40 ft., unless otherwise directed. Terminate workday production at an expansion joint.
- B. Extruded or Slipformed Concrete.** Provide any additional surface finishing immediately after extrusion or slipforming as required on the plans. Construct joints at locations as shown on the plans or as directed.

531.4. Measurement. Sidewalks will be measured by the foot or by the square yard of surface area. Curb ramps will be measured by each unit. The unit will consist of the curb ramp, landing, adjacent flares or side curb, and detectable warning surface as shown on the plans.

531.5. Payment. The work performed and materials furnished in accordance with this Item and measured as provided under "Measurement" will be paid for at the unit price bid for "Concrete Sidewalks" of the width (for foot measurement) and of the depth specified or "Curb Ramps" of the type specified. This price is full compensation for surface preparation of base; materials; removal and disposal of existing concrete; excavation, hauling and disposal of excavated material; drilling and doweling into existing concrete curb, sidewalk, and pavement; repair of adjacent street or pavement structure damaged by these operations; and equipment, labor, materials, tools, and incidentals.

Sidewalks that cross and connect to concrete driveways or turnouts will be measured and paid for in accordance with Item 530, "Intersections, Driveways, and Turnouts."

ITEM 533
SHOULDER TEXTURING

533.1. Description. Construct shoulder texturing.

533.2. Equipment.

- A. Milled-In Shoulder Texturing.** Provide a rotary-type cutting head with a maximum outside diameter of 24 in. and a minimum length of 16 in. Arrange cutting tips to provide a relatively smooth cut with approximately 1/16 in. difference in texture deviation. Provide a cutting head with independent suspension from the power unit that will self-align with the shape of the shoulder and irregularities in the shoulder surface. Provide a cutting tool with guides to provide consistent alignment of each cut relative to the roadway and to provide uniformity throughout the project.
- B. Rolled-In Shoulder Texturing.** Provide a steel-wheel or combination steel-wheel rubber-tire roller for shoulder texturing. Provide rubber tires with smooth or slick tread. Shim the axle to prevent roller movement side to side. Use a roller:
- weighing at least 6 tons or one that applies a force equivalent to a 6-ton roller.
 - equipped with a water system to moisten the drums and tires to prevent picking up bituminous material.
 - with a guidance system, clearly visible to the operator, to provide for consistent alignment.
 - that produces the required texturing.

Texture using sections of nominal 2-in. I.D. schedule 40 steel pipe fastened to the roller drum:

- Cut pipe to produce indentations 1 in. deep with a variability of 1/8 in.
- Cut pipe in 2-ft. sections, including 3-in. tapers on each end.
- Place pipe so that the center-to-center spacing of indentations is between 8 and 9 in.
- Place pipe on the non-steering drum of the roller.

533.3. Construction. Construct shoulder texturing at a distance of 4 to 6 in. from the outside edge of the edgeline as shown on the plans, or as directed. Maintain this distance throughout texturing. Leave at least 6 ft. untextured outside the shoulder, unless prohibited by shoulder width.

533.4 to 536.2

Do not place shoulder texturing across exit or entrance ramps, acceleration and deceleration lanes, crossovers, gore areas, or intersections with other roadways, or at locations not shown on the plans. Correct misplaced texturing at the Contractor's expense.

A. Milled-In Shoulder Texturing. Provide milled-in shoulder texturing 7 in. wide in the direction of travel, with 1/2-in. tolerance, and 16 in. long perpendicular to travel. Construct depressions with a concave circular arc shape, a minimum depth of 1/2 in., and a maximum depth of 5/8 in. at the center of the cut. The depressions must have well defined edges and a smooth interior finish, and not snag or tear the finished pavement. Control dust during grinding operations.

Before opening the adjacent lane to traffic, remove and dispose of debris by vacuuming or sweeping as directed.

B. Rolled-In Shoulder Texturing. Perform texturing immediately behind the breakdown rolling operation and as closely behind the paver as possible. Construct shoulder texturing in a single pass. Do not allow vehicles or equipment on the textured area for a period of 24 hr. after texturing. Position rollers used for texturing by planking or other approved methods.

533.4. Measurement. Shoulder texturing will be measured longitudinally by the 100-ft. station. Measurement will not include interruptions across ramps, acceleration or deceleration lanes, crossovers, gore areas, or intersections with other roadways.

533.5. Payment. The work performed in accordance with this Item and measured as provided for under "Measurement" will be paid for at the unit price bid for "Shoulder Texturing (Milled)" and "Shoulder Texturing (Rolled)." This price is full compensation for equipment, labor, materials, tools, and incidentals.

ITEM 536

CONCRETE MEDIANS AND DIRECTIONAL ISLANDS

536.1. Description. Construct cast-in-place concrete medians and directional islands.

536.2. Materials. Furnish materials in accordance with the following:

- Item 420, "Concrete Structures"
- Item 421, "Hydraulic Cement Concrete"

- Item 440, “Reinforcing Steel”
- Item 529, “Concrete Curb, Gutter, and Combined Curb and Gutter.”

Use Class A concrete unless otherwise shown on the plans.

536.3. Construction. Provide wood or metal forms securely held in place. Properly position and secure reinforcing steel and dowels. Place concrete for each section on the prepared foundation to line, grade, and cross-section, in accordance with Item 420, “Concrete Structures.” Separate sections from adjacent curbs or adjoining sections using expansion or contraction joints of the type and size specified on the plans. A curb section may be used for the perimeter of the median or island when shown. Construct curbs in conformance with Item 529, “Concrete Curb, Gutter, and Combined Curb and Gutter.”

Finish exposed surfaces with a wood float after sufficient concrete set. Round exposed edges as shown on the plans.

Remove forms after concrete has set. Point up exposed surfaces. Provide an ordinary surface finish in accordance with Item 427, “Surface Finishes for Concrete.” Use mortar consisting of 1 part hydraulic cement and 2 parts fine aggregate to plaster exposed formed surfaces when required. Apply the mortar with a template made to conform to the cross-section shown on the plans.

Cure at least 72 hr. using a method specified in Item 420, “Concrete Structures.”

536.4. Measurement. This Item will be measured by the foot or by the square yard to the face of the curb.

536.5. Payment. The work performed and materials furnished in accordance with this Item and measured as provided under “Measurement” will be paid for at the unit price bid for “Concrete Median” or “Concrete Directional Island.” This price is full compensation for preparing foundation surfaces; furnishing and operating equipment; curbs and gutters used as part of the concrete median or directional island; and labor, materials, tools, and incidentals.

ITEM 538

RIGHT OF WAY MARKERS

538.1. Description. Install cast-in-place concrete right of way markers.

538.2 to 540.2

538.2. Materials. Provide Class A concrete in accordance with Item 421, “Hydraulic Cement Concrete,” and reinforcing steel in accordance with Item 440, “Reinforcing Steel.” The Department will furnish bronze disks.

538.3. Construction. Cast and finish right of way markers in accordance with Item 420, “Concrete Structures,” and details shown on the plans. Install right of way markers at designated points to the required horizontal and vertical locations. Center the bronze disk within 1/2 in. of the location shown. Reposition any marker that is outside this tolerance.

Unless otherwise shown on the plans, the Department will provide a survey crew working under the direction of a registered professional land surveyor, licensed to practice in Texas, to make the final alignment checks on each right of way marker installed and to place the right of way location punch mark on the bronze disk. Do not disturb or destroy the original points before installing right of way markers with bronze disks or before placing punch marks.

538.4. Measurement. This Item will be measured by each marker.

538.5. Payment. The work performed and materials furnished in accordance with this Item and measured as provided under “Measurement” will be paid for at the unit price bid for “Right of Way Markers.” This price includes materials, labor (including work of the registered professional land surveyor when required by the plans), tools, equipment, and incidentals. Removal and disposal of existing right of way markers will not be paid for directly but is subsidiary to pertinent Items.

ITEM 540

METAL BEAM GUARD FENCE

540.1. Description. Furnish and install, replace, or adjust metal beam guard fence consisting of metal beam rail element support on timber or steel posts.

540.2. Materials. When directed, provide samples of metal beam rail elements, terminal sections, bolts, and nuts for testing for compliance with the physical and chemical property requirements of AASHTO M 180 in accordance with Tex-708-I and Tex-713-I.

When the plans designate that the Department will furnish the materials, pick up the materials at the locations shown on the plans.

- A. Metal Beam Rail Elements.** Furnish new metal beam rail elements for rail and terminal anchor sections that meet the requirements of Table 1. Type I or II is allowed unless otherwise shown on the plans. Base metal for metal beam rail elements must not contain more than 0.04% phosphorous nor more than 0.05% sulfur.
- Furnish metal beam rail elements from approved manufacturers. A list of Department-approved manufacturers is maintained by the Construction Division.
- B. Posts.** Furnish new round timber, rectangular timber, or rolled steel section posts in accordance with details shown in the plans and the following requirements:
- 1. Timber Posts.** Meet the requirements of DMS-7200, “Timber Posts and Blocks for Metal Beam Guard Fence.”
 - 2. Steel Posts.** Provide rolled sections conforming to the material requirements of ASTM A 36. Drill or punch posts for rail attachment as shown on the plans. Galvanize in accordance with Item 445, “Galvanizing.”

Table 1
Rail Element Requirements

Specification	AASHTO M 180
Class	A – Base metal nominal thickness 0.105 in. \pm 0.008 in., or B – Base metal nominal thickness 0.135 in. \pm 0.008 in.
Type	I – Zinc-coated 1.80 ounces per square foot minimum single-spot, or II – Zinc-coated 3.60 ounces per square foot minimum single-spot. IV – Weathering Steel (required when shown on the plans).
Shape	W-beam or thrie beam or W-beam-to-thrie-beam transition.
Markings	Permanently mark each metal beam rail element with the information required in AASHTO M 180. Permanently mark all curved sections of metal beam rail element with the radius of the curved section in the format “R = xx ft.” Markings (die-imprinted letters and numerals no more than 1/2 in. high) must be on the back of the metal beam rail section away from traffic and visible after erection.

- C. Blocks.** Furnish new rectangular timber or composite blocks in accordance with details shown in the plans and the following requirements:

540.3 to 540.3

1. **Timber.** Meet the requirements of DMS-7200, “Timber Posts and Blocks for Metal Beam Guard Fence.”
 2. **Composite.** Meet the requirements of DMS-7210, “Composite Material Posts and Blocks for Metal Beam Guard Fence.”
- D. Fittings.** Furnish new fittings (bolts, nuts, and washers) in accordance with the details shown on the plans and galvanized in accordance with Item 445, “Galvanizing.”
- E. Terminal Connectors.** Furnish new terminal connectors, where required, meeting the material and galvanizing requirements specified for metal beam rail elements.
- F. Concrete.** Furnish concrete for terminal anchor posts meeting the requirements for Class A concrete as required in Item 421, “Hydraulic Cement Concrete.”
- G. Curb.** If indicated in the details, furnish the curb shown with metal beam guard fence transition as required by Item 529, “Concrete Curb, Gutter, and Combined Curb and Gutter.”

540.3. Construction. Install posts and rail elements in accordance with the details shown on the plans.

- A. Posts.** Install posts by either drilling or driving.
1. **Drilling.** Drill holes and set posts plumb and firm to the line and grade shown. Backfill posts by thoroughly tamping the fill material in 4 in. layers.
 2. **Driving.** Drive posts plumb with approved power hammers (steam, compressed air, vibratory, or diesel) or gravity hammers to the line and grade shown. Use a structural steel driving head suitable for the type and size of post being driven with wood cushion blocks as necessary to prevent damage to the post. Rope mat, belting, or other similar cushioning material may be used in addition to wood cushion blocks. Use pilot holes when required or permitted. Determine the size and depth of pilot holes with the approval of the Engineer based on results of trial operations of the first few posts driven. Thoroughly tamp loosened soil around the post, fill with suitable material any void between the soil and the post resulting from the driving, and thoroughly compact to the density of adjacent undisturbed material.
- B. Rail Elements.** Erect metal beam rail elements to produce a smooth, continuous rail paralleling the line and grade of the roadway surface or as shown on the plans. Bolt rail elements end to end and lap in the

direction of traffic in the lane adjacent to the guard fence. Curve metal beam rail elements during fabrication, to the radius shown. Field-drill or punch holes in rail elements for special details only when approved.

- C. **Terminal Anchor Posts.** Embed terminal anchor posts in concrete unless otherwise shown on the plans.
- D. **Galvanizing Repair.** After erection, repair all parts of galvanized steel posts, washers, bolts, and rail elements on which the galvanizing has become scratched, chipped, or otherwise damaged. Repair in accordance with Section 445.3.D, "Repairs."
- E. **Guard Rail Adjustment.** Work includes vertical adjustment of the rail element. Perform work in accordance with details shown on the plans. Materials provided by the Department will be as shown on the plans.
- F. **Curb.** If indicated in the details, construct the curb shown with metal beam guard fence transition as required by Item 529, "Concrete Curb, Gutter, and Combined Curb and Gutter."

540.4. Measurement.

- A. **Guard Fence Installation, Adjustment, and Anchor Sections.** Measurement will be by the foot of fence. Fence will be measured on the face of the rail in place, from center to center of end posts. For terminal anchor sections or structure-to-railing connections, measure from the points shown on the plans. Terminal anchor sections will be measured by the foot, unless specified as a separate bid item.
- B. **Terminal Anchor Sections.** When a separate bid item is specified for terminal anchor sections, measurement will be by each section, complete in place, consisting of a terminal anchor post and one 25 ft. section of rail element.
- C. **Transitions.** Transitions for rail connection will be measured by each transition.

540.5. Payment. The work performed and material furnished in accordance with this Item and measured as provided under "Measurement" will be paid for at the unit price bid for "Metal W-Beam Guard Fence" of the post type specified, "Metal Thrie-Beam Guard Fence" of the post type specified, "Terminal Anchor Section," "Metal Beam Guard Fence Transition," "Metal W-Beam Guard Fence Adjustment," "Metal Thrie-Beam Guard Fence Adjustment," "Terminal Anchor Section Adjustment," or "Transition Adjustment." When weathering steel is required, Type IV will be specified.

542.1 to 542.1

When posts are required to be removed, payment for removal of posts, rail elements, fittings, and terminal anchor sections will be made under Item 542, "Removing Metal Beam Guard Fence." Guardrail end treatments will be paid for in accordance with Item 544, "Guardrail End Treatments."

Samples furnished to the Department for testing purposes will not be paid for directly but are subsidiary to this Item. Special backfill materials required will not be paid for directly but are subsidiary to this Item. Concrete curbs will not be paid for directly but are subsidiary to this Item.

- A. Guard Fence.** The price bid for "Metal W-Beam Guard Fence" or "Metal Thrie-Beam Guard Fence" is full compensation for materials, hauling, erection, setting posts in concrete, blocks, driving posts, excavating, backfilling, equipment, labor, tools, and incidentals.
- B. Terminal Anchor Section.** When a separate bid item is specified, the price bid for "Terminal Anchor Section" is full compensation for furnishing the rail element, anchor assembly, terminal anchor post, and foundations; installing the rail element anchor assembly and the terminal anchor post and foundations; excavation and backfilling; and equipment, labor, tools, and incidentals.
- C. Transition.** The price bid for "Metal Beam Guard Fence Transition" is full compensation for furnishing the nested sections of thrie beam, the thrie-beam-to-W-beam transitional rail piece, posts, concrete, curb, connections to W-beam guard fence and bridge rails, and the thrie-beam terminal connectors; excavation and backfilling; and equipment, labor, tools, and incidentals.
- D. Guard Rail Fence Adjustment.** The price bid for "Metal W-Beam Guard Fence Adjustment," "Metal Thrie-Beam Guard Fence Adjustment," "Terminal Anchor Section Adjustment," and "Transition Adjustment" is full compensation for furnishing materials not supplied by the Department, drilling holes in posts, hauling, erection, blocks, excavation, backfill, cleaning, salvaging materials, setting rail element anchor assembly and terminal anchor post, removal of rail element, concrete, curb, equipment, labor, tools, and incidentals.

ITEM 542

REMOVING METAL BEAM GUARD FENCE

542.1. Description. Remove existing metal beam guard fence and store at locations shown on the plans or as directed.

542.2. Construction. Remove rail elements in original lengths. Remove fittings from the posts and the metal rail and then pull the posts. Do not mar or damage salvageable materials during removal.

Completely remove posts and any concrete surrounding the posts. Furnish backfill material and backfill the hole with material equal in composition and density to the surrounding soil unless otherwise directed.

Cut off or bend down eyebolts anchored to the deadman to an elevation at least 1 ft. below the new subgrade elevation and leave in place along with the deadman.

Neatly stack salvaged materials to be retained by the Department at designated sites shown on the plans. Properly dispose of unsalvageable materials in accordance with federal, state, and local regulations. Repair or replace Contractor-damaged salvageable material at the Contractor's expense.

542.3. Measurement. This Item will be measured by the foot of fence in its original position. Measurement will be made along the face of the rail in place including metal beam guard fence transitions and single guardrail terminal sections, from center to center of end posts and from terminal points shown on the plans.

When "Removing Terminal Anchor Sections" is specified as a separate bid item, measurement will be made by each section removed. A section consists of a terminal anchor post and one 25-ft. rail element.

542.4. Payment. The work performed and materials furnished in accordance with this Item and measured as provided under "Measurement" will be paid for at the unit price bid for "Removing Metal Beam Guard Fence" or "Removing Terminal Anchor Sections." This price will be full compensation for removing materials; loading, hauling, unloading, and storing or disposal; furnishing backfill material; backfilling postholes; and equipment, labor, tools, and incidentals.

Removing single guardrail terminals and metal beam guard fence transitions will be measured by the foot and paid for at the price bid for "Removing Metal Beam Guard Fence." Removal of curb associated with the metal beam guard fence transitions will not be paid for directly, but will be subsidiary to this Item.

544.1 to 544.5

ITEM 544

GUARDRAIL END TREATMENTS

544.1. Description. Furnish and install, move, or remove guardrail end treatments.

544.2. Materials. Furnish new materials from the approved list maintained by the Construction Division. When the plans designate that the Department will furnish materials, pick them up at the location shown on the plans.

544.3. Construction. Install guardrail end treatments in accordance with manufacturer requirements and the details shown on the plans. Obtain assembly and installation information for the guardrail end treatments from the manufacturer. Provide the Engineer with installation and repair manuals specific to the guardrail end treatment prepared by the manufacturer.

Move or remove guardrail end treatments in accordance with the plans and as directed. Deliver salvageable materials in accordance with the plans or as directed. Dispose of unsalvageable materials in accordance with federal, state, and local regulations.

544.4. Measurement. This Item will be measured by each guardrail end treatment.

544.5. Payment. The work performed and the materials furnished in accordance with this Item and measured as provided for under “Measurement” will be paid for at the unit price bid for “Guardrail End Treatment (Install),” “Guardrail End Treatment (Move and Reset),” or “Guardrail End Treatment (Remove).” This price is full compensation for foundations, materials, stockpiling, disposal of unsalvageable materials, equipment, labor, tools, and incidentals.

Payment for “Guardrail End Treatment (Move and Reset)” will include each guardrail end treatment removed from a stockpile or from an existing location and reset in a new location as detailed on the plans or as directed.

Payment for “Guardrail End Treatment (Remove)” will include each guardrail end treatment removed from an existing location and stockpiled in the area designated on the plans or as directed or disposed.

ITEM 545**CRASH CUSHION ATTENUATORS**

545.1. Description. Furnish and install, move and reset, or remove crash cushion attenuators.

545.2. Materials.

- A. Crash Cushion Attenuators.** Furnish new crash cushion attenuators in accordance with the details shown on the plans and on the manufacturer's shop drawings, or equal as approved. When the plans designate that the Department will furnish the crash cushion attenuators, pick them up at the location shown on the plans.
- B. Concrete.** Furnish Class S concrete for pads that meets Item 421, "Hydraulic Cement Concrete."

545.3. Construction. Perform the following as shown on the plans:

- A. Installation.** Assemble and install crash cushion attenuators in accordance with the details shown on the plans and manufacturer recommendations. Obtain assembly and installation information for the crash cushion attenuators from the manufacturer and provide the Engineer with an installation and repair manual specific to the crash cushion attenuators.
- B. Moving and Resetting.** Remove crash cushion attenuators from a stockpile or from an existing location and reset in a new location as shown on the plans or as directed. Install crash cushion attenuators in accordance with pertinent standards and manufacturer recommendations. Provide additional materials to complete the installation as needed. Dispose of unsalvageable materials in accordance with federal, state, and local regulations.
- C. Removal.** Remove crash cushion attenuators from an existing location and stockpile in the area designated on the plans or as directed or dispose. Remove crash cushion attenuators in accordance with the plans and as directed. Clean and repair salvageable units before inspection by the Engineer, and return them to the Department. Dispose of unsalvageable materials in accordance with federal, state, and local regulations.

545.4. Measurement. This Item will be measured by each crash cushion attenuator.

545.5 to 550.2

545.5. Payment. The work performed and the materials furnished in accordance with this Item and measured as provided for under “Measurement” will be paid for at the unit price bid for “Crash Cushion Attenuator (Install),” “Crash Cushion Attenuator (Move and Reset),” and “Crash Cushion Attenuator (Remove)” of the model and type specified (where required by the standard). This price is full compensation for foundations; materials, stockpiling, moving and removing, hauling, installing and resetting, disposal of unsalvageable materials, equipment, labor, tools, and incidentals.

ITEM 550 CHAIN LINK FENCE

550.1. Description. Furnish, install, remove, repair, or replace chain link fence and gates.

550.2. Materials. Before installation of the chain link fence, furnish certification from the fence materials manufacturer stating that all fencing materials comply with the requirements of this Item. Use only new materials.

- A. General.** Furnish materials in accordance with the following:
- Item 421, “Hydraulic Cement Concrete,” Class B
 - Item 445, “Galvanizing.”
- B. Wire Fabric.** Provide wire fabric with:
- 9 gauge (0.148 in. diameter) steel wire with a minimum breaking strength of 1,290 lb. meeting ASTM A 392 Class I or ASTM A 491;
 - mesh size of 2 in. \pm 1/8 in. between parallel wires with at least 7 meshes in a vertical dimension of 23 in. along the diagonals of the openings; and
 - knuckled selvages at the top and bottom edge of the fabric, unless otherwise shown on the plans.
- C. Posts.** Provide posts of the size and weight shown on the plans. Do not provide rerolled or open-seam posts. Use material meeting ASTM F 1083 for all posts. When specified, furnish thin-wall, high-strength pipe posts manufactured by cold rolling using steel strip conforming to ASTM A 1011, CS (Commercial Steel).
- D. Post Caps.** Provide malleable iron post caps designed to exclude all moisture. If barbed wire is shown on the plans, furnish barbed wire support arms integral with the post caps. If top rail is shown on the

plans, furnish post caps with an opening for the top rail. Post caps must have a 2-in. skirt.

- E. Gates.** Provide gates fabricated from round sections of pipe of the size and weight shown on the plans. Use material meeting ASTM F 1083 for all gate pipes. For each gate, include:
- corner and tee fittings of malleable iron or pressed steel with means for attaching diagonal bracing members;
 - hinges of malleable iron allowing a full 180° swing, easily operated by one person;
 - ball-and-socket-type bottom hinges that do not twist or turn from the action of the gate and prevent the closed gate from being lifted off the hinges;
 - a positive stop that prevents any portion of the gate from swinging over an adjacent traffic lane;
 - malleable iron pulley systems for roll type gate (only when required);
 - diagonal braces consisting of 3/8-in.-diameter cable with turnbuckles, 2 to each gate frame, and, for vehicle gates, a vertical pipe brace of the size and weight shown on the plans at the center of each gate leaf;
 - latches of malleable iron or steel for single gates with a single-fork latch and padlock eye that will keep the gate closed;
 - two fork latches mounted on a center plunger rod with a padlock eye for double-leaf gates;
 - holdbacks for each leaf of vehicular gates, with a semi-automatic holdback catch anchored at least 12 in. into a 12 in.-diameter by 24 in.-deep concrete footing; and
 - a malleable iron center rest, designed to receive the plunger rod anchored as shown on the plans for all double-leaf gates.
- F. Top Rail.** When shown on the plans, provide top rail manufactured from 1.660 in. OD standard weight (Schedule 40) steel pipe weighing 2.27 lb. per foot or high-strength pipe weighing 1.82 lb. per foot. Use material meeting ASTM F 1083 for all top rail pipes. Provide pipe in sections at least 18 ft. long joined with outside steel sleeve couplings at least 6 in. long with a minimum wall thickness of 0.70 in. Use couplings designed to allow for expansion of the top rail.
- G. Tension Wire.** Use 7 gauge (0.177-in.) carbon steel wire with a minimum breaking strength of 1,950 lb. for the bottom edge of all fence fabric, and for the top edge of fence fabric when a top rail is not specified.

550.2 to 550.2

- H. Truss Bracing.** Provide truss bracing as shown on the plans.
- I. Cables.** Provide 7-wire strand cables manufactured of galvanized annealed steel at least 3/8 in. in diameter.
- J. Barbed Wire.** When specified on the plans, provide 3 strands of twisted 12.5 gauge barbed wire with 2-point, 14 gauge barbs spaced approximately 5 in. apart conforming to ASTM A 121 or ASTM A 585.
- K. Barbed Wire Support Arms.** When barbed wire is specified on the plans, provide support arms at an angle of 45° from vertical, with clips for attaching 3 strands of barbed wire to each support arm and sufficient strength to support a 200-lb. weight applied at the outer strand.
- L. Stretcher Bars.** Provide stretcher bars made of flat steel at least 3/16 in. by 3/4 in. and not more than 2 in. shorter than the fabric height. Provide 1 stretcher bar for each gate and end post and 2 stretcher bars for each corner and pull post.
- M. Grounds.** Provide copper-clad steel rods 8 ft. long with a minimum diameter of 5/8 in., or other UL-listed ground rods.
- N. Miscellaneous Fittings and Fasteners.** Furnish in sufficient quantities to erect all fencing materials in a proper manner. Furnish fittings for posts from pressed or rolled steel, forged steel, malleable iron or wrought iron of good commercial quality spaced as shown on the plans.
- O. Coatings.** Unless specified on the plans, hot-dip galvanize all materials. Fabric, tension wire, and barbed wire may be aluminum-coated or alloy-coated if approved. When shown on the plans, additionally coat all material except bolts, nuts, and washers with thermally fused polyvinyl chloride (PVC) in accordance with ASTM F 668, Class 2B, meeting the specified color.
 - 1. Fabric.**
 - a. Galvanizing.** Hot-dip galvanize in accordance with ASTM A 392, Class I.
 - b. Aluminum Coating.** Aluminum-coat in accordance with ASTM A 491.
 - c. Alloy Coating.** Coat with zinc-5% aluminum-mischmetal alloy (Zn-5Al-MM) in accordance with ASTM F 1345, Class I.

2. **Posts.**
 - a. **Inside and Outside Galvanizing.** Hot-dip galvanize inside and outside in conformance with ASTM F 1083.
 - b. **Alloy Coating.** Coat inside and outside with Zn-5A1-MM in accordance with ASTM F 1043, Class C.
3. **Braces and Gates.**
 - a. **Galvanizing.** Hot-dip galvanize braces and gates inside and out in conformance with ASTM F 1083.
 - b. **Alloy Coating.** Coat inside and out with (Zn-5A1-MM) in accordance with ASTM F 1043, Class C.
4. **Fittings, Bolts, and Other Miscellaneous Hardware.** Galvanize all fittings, bolts and miscellaneous hardware in conformance with Item 445, "Galvanizing."
5. **Tension Wire.** Zinc-coat tension wire with a minimum coating of 0.80 oz./sq. ft. or aluminum-coat with a minimum coating of 0.30 oz./sq. ft.
6. **Barbed Wire.** Zinc-coat barbed wire in accordance with ASTM A 121 (0.80 oz./sq. ft.) or aluminum-coat in accordance with ASTM A 585 (0.30 oz./sq. ft.).
7. **Pull Cable.** Zinc-coat pull cable with a minimum coating of 0.80 oz./sq. ft. of individual-wire surface when tested in conformance with ASTM A 116.

550.3. Construction. Erect the chain link fence to the lines and grades established on the plans. Overall height of the fence when erected is the height above the grade shown.

Repair or replace damaged fence or gates. If posts cannot be repaired by straightening, remove and replace the post and foundation. When a fence installation is to be removed in its entirety and not replaced, return all salvageable material to the location shown on the plans. Backfill all postholes with suitable material. Return the salvaged fence fabric in secured rolls not more than 50 ft. long. Dispose of unsalvageable material.

A. Clearing and Grading. Clear all brush, rocks, and debris necessary for the installation of this fencing.

Unless otherwise shown on the plans, stake the locations for corner posts and terminal posts. Follow the finished ground elevations for fencing panels between corner and terminal posts. Level off minor irregularities in the path of the fencing.

B. Erection of Posts. Install posts as shown on the plans. Plumb and permanently position posts with anchorages firmly set before fabric is placed. Brace corner and pull posts as shown on the plans.

1. Post Spacing. Space posts as shown in Table 1.

**Table 1
Post Spacing and Placement**

Post Type	Required Spacing or Placement
Line posts	at most 10 ft. apart
Pull posts	at most 500 ft. apart and at each change in direction exceeding 20° vertically
Corner posts	at each horizontal angle point

Install cables on all terminal posts and extend to adjacent posts. Install cables on each side of corner and pull posts with a 3/8-in. drop-forged eye-and-eye or eye-and-clevis turnbuckle, unless otherwise shown on the plans.

2. Postholes. Drill holes for concrete footings for all posts to provide footings of the dimensions shown on the plans.

Where solid rock is encountered before reaching plan depth, penetrate the solid rock by at least 12 in. (18 in. for end, corner, gate, and pull posts) or to plan depth. Drill holes in the solid rock with a diameter at least 1 in. greater than the outside diameter of the post.

After the posts are set and plumbed, fill the hole in the solid rock with grout consisting of 1 part hydraulic cement and 3 parts clean, well-graded sand. Other grouting materials may be used if approved. Thoroughly work the grout into the hole, leaving no voids. Construct concrete footings from the solid rock to the top of the ground.

3. Gate Posts. Align the tops of all gate frames with the fencing top tension wire or top rail. If curbs are shown on the plans, provide vehicular gates that are greater in overall height than the adjacent fencing by the height necessary to extend to within 2 in. of the pavement between the curbs.

4. Concrete Footings. Center posts in their footings. Place concrete and compact by tamping or other approved methods. Machine mix all batches of concrete over 1/2 cu. yd. Hand mixing concrete is allowed on batches under 1/2 cu. yd.

Use forms for footings where the ground cannot be satisfactorily excavated to neat lines. Crown the concrete or grout (for solid rock) to carry water from the post. Keep the forms in place for at least 24 hr. Backfill the footing with moistened material as soon as each form is removed, and thoroughly tamp. Cover concrete with at least 4 in. of loose moist material, free of clods and gravel, immediately after placing concrete. No other curing is required.

Spread all excess excavated and loose material used for curing neatly and uniformly. Remove excess concrete and other construction debris from the site.

- C. Erection of Fabric.** After all posts have been permanently positioned and anchorages firmly set, place the fabric with the cables drawn taut with the turnbuckles. Secure one end and apply enough tension to the other end to remove all slack before making attachments. Unless otherwise shown on the plans, cut the fabric and independently attach each span at all corner posts and pull posts.

Follow the finished contour of the site with the bottom edge of fabric located approximately 2 in. above the grade. Grade uneven areas so the maximum distance between the bottom of fabric and ground is 6 in. or less.

Fasten fabric at 12 in. intervals to the top and bottom tension wires between posts. When top rail is shown on the plans, fasten the fabric in the same manner. On gate frames, fasten the fabric to the top and bottom of the gate frame at 12 in. intervals. Use steel wire fabric ties of 9 gauge steel or larger. Fasten fabric to terminal posts by steel stretcher bars and stretcher bar bands fitted with carriage bolts and nuts of the size and spacing shown on the plans. Use stretcher bars to fasten endposts, pull posts, corner posts, and gateposts with stretcher bar bands at intervals of at most 15 in. Attach stretcher bars to terminal posts with 1 in. \times 1/8 in. flat steel bands with 3/8-in. carriage bolts at intervals up to 15 in.

- D. Electrical Grounds.** Provide at least 1 electrical ground for each 1,000 ft. of fence, located near the center of the run. Provide additional grounds directly under the point where power lines pass over the fence.

Vertically drive or drill in the grounding rod until the top of the rod is approximately 6 in. below the top of the ground. Connect a No. 6 solid copper conductor to the rod and to the fence by a UL-listed method so that each element of the fence is grounded.

550.4 to 550.5

- E. Repair of Coatings.** Repair damaged zinc coating in accordance with Section 445.3.D, “Repairs.”

550.4. Measurement. Chain link fence will be measured by the foot of fence installed, repaired, replaced, or removed, measured at the bottom of the fabric along the centerline of the fence from center to center of posts, excluding gates.

Gates will be measured as each gate installed, repaired, replaced, or removed.

550.5. Payment. The work performed and materials furnished in accordance with this Item and measured as provided under “Measurement” will be paid for at the unit price bid for “Chain Link Fence (Install)” or “Chain Link Fence (Repair)” of the height specified or “Chain Link Fence (Remove)” and “Gate (Install)” or “Gate (Repair)” of the type, height, and width of opening specified or “Gate (Remove).” Clearing and grading for fencing and gates will not be paid for directly but is subsidiary to this Item.

- A. Chain Link Fence (Install).** This price is full compensation for furnishing and installing fencing, except gates; cleaning, grading, and backfilling; removing and disposing of surplus material; and equipment, labor, tools, and incidentals.
- B. Chain Link Fence (Repair).** This price is full compensation for furnishing materials; repairing or replacing fencing, except gates; cleaning, grading, and backfilling; removing and disposing of surplus or damaged material; and equipment, labor, tools, and incidentals.
- C. Chain Link Fence (Remove).** This price is full compensation for removing all fencing, except gates; cleaning, grading, and backfilling; removing and disposing of surplus material; and equipment, labor, tools, and incidentals.
- D. Gate (Install).** This price is full compensation for installing gate and for providing materials, center anchorages, equipment, labor, tools, and incidentals.
- E. Gate (Repair).** This price is full compensation for repairing or replacing gate and for furnishing materials; removing and disposing of damaged materials; and equipment, labor, tools, and incidentals.
- F. Gate (Remove).** This price is full compensation for removing gate and for materials, equipment, labor, tools, and incidentals.

ITEM 552
WIRE FENCE

552.1. Description. Furnish and construct fence of barbed wire or a combination of woven fence fabric and barbed wire, supported on metal or wood posts.

552.2. Materials. Furnish materials in accordance with details shown on the plans and with the requirements of this Article.

A. Metal Posts and Braces. If steel pipe is used for posts and braces, use steel pipe in accordance with ASTM A 53. For T-posts, use steel that meets ASTM A 702. Use only new steel. Do not use rerolled or open-seam material. Furnish galvanized steel sections in accordance with Item 445, "Galvanizing." When painting is specified, use an approved anticorrosive coating. After installation of painted posts and braces, spot-coat damaged areas with the same paint color. Use paint with at least the same anticorrosive properties as the original paint. Use the size, weight, and area of posts, braces, and anchor plates shown on the plans.

B. Wood Posts and Braces.

1. **Untreated Wood.** Provide cedar or juniper timber.
2. **Treated Wood.** Provide pine or fir timber treated in accordance with Item 492, "Timber Preservative and Treatment." Remove outer bark and all inner cambium bark on treated posts, except those occasional strips of bark may remain if not over 1/2 in. wide or over 3 in. long.

Use sound timber that is free from decay, shakes, splits, or other defects that would weaken the posts or braces or otherwise make them structurally unsuitable for the purposes intended. Knots that are sound, tight, trimmed flush, and not in clusters will be allowed, provided they do not exceed 1/3 of the small diameter or the least dimension of the posts and braces. Remove spurs and splinters, cutting the ends square.

C. Gates and Gateposts. Furnish materials to the dimensions shown on the plans, or as directed.

D. Barbed Wire. Furnish barbed wire in accordance with ASTM A 121, Class 1. Use barbed wire consisting of 2 strands of 12-1/2 gauge wire, twisted with 2-point 14 gauge barbs spaced no more than 5 in. apart, or other barbed wire as directed.

552.3 to 552.5

- E. Wire Mesh.** Furnish wire mesh fabric in accordance with ASTM A 116, Class 1 to the height and design shown on the plans. Use at least 10 gauge wire for the top and bottom wires and at least 12-1/2 gauge wire for the intermediate wires and vertical stays.
- F. Miscellaneous.** Furnish galvanized bolts, nuts, washers, braces, straps, and suitable devices for holding barbed wire and wire mesh firmly to metal posts. Use material of good commercial quality and design. Provide galvanized staples, at least 1-1/2 in. long.

552.3. Construction. Space fence posts as shown on the plans. Set fence posts plumb and firm at the intervals, depth, and grade shown on the plans. Brace corner and pull posts in 2 directions. Brace end posts and gateposts in 1 direction. Install a corner post where the alignment changes 30° or more. At alignment angles between 15 and 30°, brace the angle post to the adjacent line posts with diagonal tension wires.

At grade depressions where stresses tend to pull posts out of the ground, snub or guy the fencing at the critical point with a double 9 gauge galvanized wire. Connect the wire to the top horizontal line of the barbed wire or to the top and bottom wire or wire mesh fabric, and to a deadman weighing at least 100 lb. Stretch the fence before guying and snubbing.

Install corner, end, or angle post assembly before stretching the wire between posts. Connect existing cross fences to the new fences and corner posts at junctions with existing fences. While drawing barbed wire and wire fabric taut, fasten to posts using galvanized ties or staples, or as shown on the plans. Install pull post assemblies at 500-ft. intervals for steel posts and at 1,000-ft. intervals for wood posts. Metal line posts may be driven provided driving does not damage the posts. Metal corners, ends, pull posts, and braces must be set in concrete footings crowned at the top to shed water. Thoroughly tamp backfill in 4-in. layers. Notch timber posts as shown in the plans.

552.4. Measurement. Fencing will be measured by the foot of wire fence, excluding gates. Gates will be measured as each gate.

552.5. Payment. The work performed and materials furnished in accordance with this Item and measured as provided under "Measurement" will be paid for at the unit price bid for "Wire Fence" or "Gate" of the type specified. This price is full compensation for furnishing, preparing, hauling, and installing fence and gate materials; excavation, backfilling, and disposal of surplus material; removal and trimming of brush and tree limbs; and equipment, labor, tools, and incidentals.

Unless otherwise shown on the plans, removal of existing fence will not be paid for directly but will be subsidiary to pertinent Items.

ITEM 556
PIPE UNDERDRAINS

556.1. Description. Install pipe underdrains.

556.2. Materials.

- A. Pipe.** Furnish the types and sizes of pipe specified on the plans. Use only one type of pipe for any underdrain system on the project. Use perforated pipe in areas to be drained, and use non-perforated pipe between the perforated pipe and the outfall.
1. **Type 1.** Corrugated steel pipe conforming to any type specified in AASHTO M 36, fabricated from corrugated galvanized sheet.
 2. **Type 2.** Corrugated aluminum pipe conforming to AASHTO M 196, Type I or IA, fabricated from corrugated sheet.
 3. **Type 3.** Bituminous-coated corrugated steel pipe conforming to the requirements of Type 1 and uniformly coated inside and out with a minimum thickness of 0.05 in. with a bituminous material meeting the requirements of Table 1 when tested in accordance with Tex-522-C.

Table 1
Requirements of Bituminous Material

Test	Requirements
Solubility, % by wt. in trichloroethylene	99.5 min.
Brittleness	Pass
Flow, in.	0.25 max

4. **Type 4.** Bituminous-coated corrugated aluminum pipe conforming to the requirement of Type 2 and uniformly coated inside and out with a minimum thickness of 0.05 in. with a bituminous material meeting the requirements of Table 1 when tested in accordance with Tex-522-C.
5. **Type 5.** Acrylonitrile-butadiene-styrene pipe conforming to ASTM D 2751, SDR-35. Perforations must meet the requirements of AASHTO M 278.

- 6. **Type 6.** Corrugated polyethylene plastic tubing conforming to ASTM M 252.
 - 7. **Type 7.** Corrugated polyvinyl chloride (PVC) pipe conforming to ASTM F 949.
 - 8. **Type 8.** Smooth-wall PVC pipe conforming to AASHTO M 278, Class PS 46.
 - 9. **Type 9.** As shown on the plans.
- B. Filter Material.** Furnish hard, durable, and clean sand, gravel, crushed stone, or crushed shell, unless otherwise shown on the plans, free of clay balls or other organic or deleterious matter as determined by Tex-413-A, that meets the gradation by percent weight specified in Table 2. Do not furnish crushed limestone unless shown on the plans. Use only one type of filter material for any underdrain system on a project.

Table 2
Percent Retained On Sieve (Tex-401-A)

Sieve Size	Type A	Type B	Type C	Type D
1-1/2"	—	—	0–10	
3/4"	—	0–10	20–40	
3/8"	—	15–35	—	—
No. 4	0–10	35–55	40–60	0–5
No. 8				0–20
No.16				15–50
No. 20	35–65 ¹	35–65 ¹	35–65 ¹	
No. 30				40–75
No. 50	75–100 ¹	75–100 ¹	75–100 ¹	70–90
No. 100				90–100

1. Of the portion finer than No. 4 sieve.

Loss by decantation as determined by Tex-406-A must not exceed 1% of the material retained on a No. 4 sieve or 4% of the material passing a No. 4 sieve. Use Type B or Type C filter material around the underdrains unless otherwise shown on the plans. Do not place Type A or Type D filter material within 6 in. of perforations.

- C. Filter Fabric.** Meet DMS-6200, “Filter Fabric,” Type 1.
- D. Riprap.** When required, provide concrete riprap in accordance with Item 432, “Riprap.”

556.3. Construction. Begin excavation of the trench at the outfall and proceed toward its upper end, following the lines and grades shown on the plans or as directed by the Engineer. Hold the minimum horizontal limits of excavation for filter material to the dimensions shown in Table 3 or as shown on the plans.

Table 3
Minimum Horizontal Limits of Excavation for Filler Material

Depth of Trench (ft.)	Distance Outside Neat Lines of Pipe Underdrains (ft.)
0 to 6	1.00
Over 6 to 10	1.50
Over 10 to 15	2.00
Over 15	2.50

In areas to be drained, place filter fabric in the bottom and sides of the trench before placing pipe or filter material, as shown in Figure 1. Provide enough width of fabric to overlap on top of the filter material. Center perforated pipe in the excavated ditch with the perforations below the horizontal axis. Join the pipe with appropriate couplers if required. Join plastic pipe in accordance with the manufacturer's recommendations. Do not use tarpaper strips. Before placing filter material, obtain the Engineer's approval of pipe placement.

Place filter material at least 12 in. above the bottom of the pipe or as shown on the plans. Do not allow filter material to displace the pipe.

After placing pipe and filter material, lap filter fabric over the top of the filter material according to the manufacturer's recommendation or as shown on the plans.

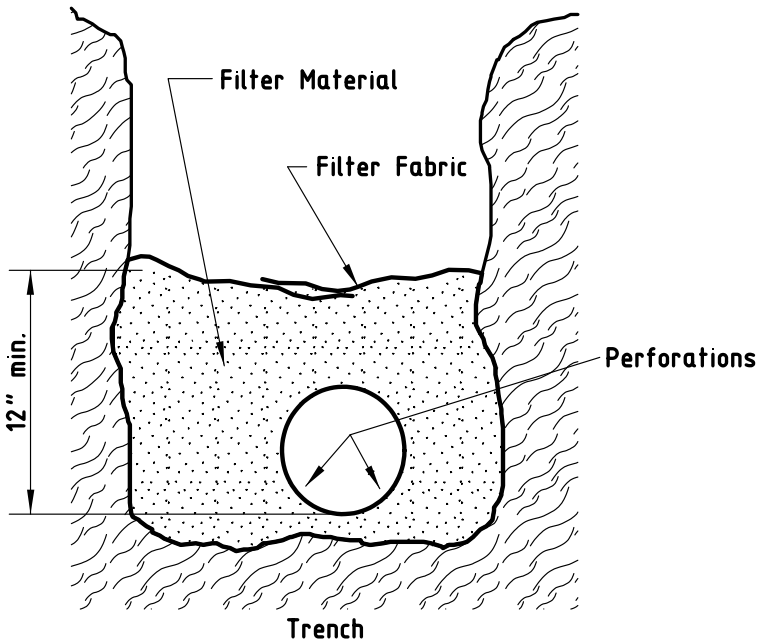

Figure 1
Installation process.

Install non-perforated pipe sections between the perforated pipe and the outfall. The sections of non-perforated pipe do not require filter fabric or filter material.

Place approved plugs in the upper ends of all pipe. Cover exposed outfall ends with 1/2-in. galvanized hardware cloth as directed by the Engineer. When required, provide Class B concrete riprap in accordance with Item 432, "Riprap," and details shown on the plans. Place the riprap to the contour and grade of the embankment slope. Cut the pipe to the slope of the riprap.

Backfill the remainder of the trench with suitable material in layers not to exceed 6 in.

556.4. Measurement. This Item will be measured by the foot along the top of the pipe and will include the length of elbows, Y's, T's, and other branches.

556.5. Payment. The work performed and material furnished in accordance with this Item and measured as provided under “Measurement” will be paid for at the unit price bid for “Pipe Underdrains” of the pipe type and size specified. This price is full compensation for pipe, couplers, plugs, screens, filter material, filter fabric, riprap, excavation, backfill, equipment, labor, materials, tools, and incidentals.

Protection methods for excavations deeper than 5 ft. will be measured and paid for in accordance with Item 402, “Trench Excavation Protection.”

ITEM 560

MAILBOX ASSEMBLIES

560.1. Description. Install, remove, temporarily relocate, or replace mailbox assemblies of the type specified.

560.2. Materials. Furnish mailbox assemblies in accordance with the plans. Provide new mailbox assemblies for permanent installations.

560.3. Construction. Temporarily relocate mailbox assemblies as shown on the plans or as directed. Furnish and mount mailboxes on approved temporary mailbox assemblies during relocation. Maintain mailbox assemblies in a serviceable condition. Furnish and install additional mailbox assemblies as directed. Relocate mailbox assemblies to permanent locations upon completion of construction work.

560.4. Measurement. This Item will be measured by each mailbox assembly installed.

560.5. Payment. The work performed and materials furnished in accordance with this Item and measured as provided under “Measurement” will be paid for at the unit price bid for “Mailbox Installation (Single),” “Mailbox Installation (Double),” or “Mailbox Installation (Multiple).”

This price is full compensation for installing mailboxes and reflectors in permanent locations, materials, equipment, labor, tools, and incidentals. Removing existing and temporary mailbox assemblies and installing and moving temporary mailbox assemblies will not be paid for directly, but will be subsidiary to pertinent Items.

ITEM 585

RIDE QUALITY FOR PAVEMENT SURFACES

585.1. Description. Measure and evaluate the ride quality of pavement surfaces.

585.2. Equipment.

- A. Surface Test Type A.** Provide a 10-ft. straightedge.
- B. Surface Test Type B.** Provide a high-speed or lightweight inertial profiler, certified at the Texas Transportation Institute. Provide the Engineer with equipment certification documentation. Display a current decal on the equipment indicating the certification expiration date.

Use a certified profiler operator from the Construction Division's approved list. When requested, furnish the Engineer documentation for the person certified to operate the profiler.
- C. Diamond Grinding Equipment.** When grinding is required, provide self-propelled powered grinding equipment that is specifically designed to smooth and texture pavements using circular diamond blades. Provide equipment with automatic grade control capable of grinding at least 3 ft. of width longitudinally in each pass without damaging the pavement.

585.3. Work Methods. Measure and evaluate profiles using Surface Test Types A and B on surfaces as described below unless otherwise shown on the plans.

- A. Transverse Profile.** Measure the transverse profile of the finished riding surface in accordance with Surface Test Type A.
- B. Longitudinal Profile.** Measure the longitudinal profile of the surface, including horizontal curves.
 - 1. Travel Lanes.** Unless otherwise shown on the plans, use Surface Test Type B on the finished riding surface of all travel lanes except as follows.
 - a. Service Roads and Ramps.** Use Surface Test Type A on service roads and ramps unless Surface Test Type B is shown on the plans.
 - b. Short Projects.** Use Surface Test Type A when project pavement length is less than 2,500 ft. unless otherwise shown on the plans.

- c. **Bridge Structures.** For span type bridge structures, approach slabs, and the 100 ft. leading into and away from such structures, measure the profile in accordance with the pertinent item or use Surface Test Type A.
 - d. **Leave-out Sections.** Use Surface Test Type A for areas listed on the plans as leave-out sections.
 - e. **Ends.** Use Surface Test Type A on the first and last 100 ft. of the project pavement length.
2. **Shoulders and Other Areas.** Use Surface Test Type A for shoulders and all other areas including intermediate pavement layers.
- C. **Profile Measurements.** Measure the finished surface in accordance with Surface Test Type A or B in accordance with Section 585.3.A, “Transverse Profile”; Section 585.3.B, “Longitudinal Profile”; and the plans.

1. **Surface Test Type A.** Test the surface with a 10-ft. straightedge at locations selected by the Engineer.

2. **Surface Test Type B.**

a. **Quality Control (QC) Testing.** Perform QC tests on a daily basis throughout the duration of the project. Use a 10-ft. straightedge, inertial profiler, profilograph, or any other means to perform QC tests.

b. **Quality Assurance (QA) Testing.** Perform QA tests using either a high-speed or lightweight inertial profiler. Coordinate with and obtain authorization from the Engineer before starting QA testing. Perform QA tests on the finished surface of the completed project or at the completion of a major stage of construction as approved by the Engineer. Perform QA tests within 7 days after receiving authorization.

The Engineer may require QA testing to be performed at times of off-peak traffic flow. Operate the inertial profiler in a manner that does not unduly disrupt traffic flow as determined by the Engineer. When using a lightweight inertial profiler to measure a surface that is open to traffic, use a moving traffic control plan in accordance with Part 6 of the TMUTCD and the plans.

In accordance with Tex-1001-S, operate the inertial profiler and deliver test results to the Engineer within 24 hr. of testing.

Provide all profile measurements to the Engineer in electronic data files using the format specified in Tex-1001-S.

(1) **Verification Testing.** Within 10 working days after the Contractor's QA testing is completed for the project or major stage of construction, the Engineer may perform ride quality verification testing. When the Department's profiler produces an overall average international roughness index (IRI) value that is more than 3.0 in. per mile higher than the value calculated using Contractor data, the Engineer will decide whether to accept the Contractor's data, use the Department's data, use an average of both party's data, or request a referee test. Referee testing is mandatory if the difference is greater than 6.0 in. per mile.

(2) **Referee Testing.** The Construction Division will conduct referee testing, and their results are final. The Construction Division may require recertification for the Contractor's or Department's inertial profiler.

D. Acceptance Plan and Pay Adjustments. The Engineer will evaluate profiles for determining acceptance, bonus, penalty, and corrective action.

1. **Surface Test Type A.** Use diamond grinding or other methods approved by the Engineer to correct surface areas that have more than 1/8-in. variation between any 2 contacts on a 10-ft. straightedge. For asphalt concrete pavements, fog seal the aggregate exposed from diamond grinding. Following correction, retest the area to verify compliance with this Item.

2. **Surface Test Type B.** The Engineer will use the QA test results and the corresponding values in Table 1 to determine pay adjustments for ride quality using Department software. IRI values will be calculated using the average of both wheel paths. When taking corrective actions to improve a deficient 0.1-mi. section, pay adjustments will be based on the data obtained from reprofiling the corrected area.

a. **IRI Pay Adjustment for 0.1-mi. Sections.** Unless pay adjustment Schedule 1 or 2 is shown on the plans, Schedule 3 from Table 1 will be used to determine the level of bonus or penalty for each 0.1-mi. section on the project.

When Schedule 3 is specified, no associated bonuses will be paid for any 0.1-mi. section that contains localized roughness.

- b. IRI Deficient 0.1-mi. Sections.** When pay adjustment Schedule 1 or 2 is specified, use diamond grinding or other approved work methods to correct any 0.1-mi. section with an average IRI over 95.0 in. per mile (IRI deficient). Correct the deficient section to an IRI of 65 in. per mile or less when Schedule 1 is specified and to an IRI of 75 in. per mile or less when Schedule 2 is specified. After making corrections, reprofile the pavement section to verify that corrections have produced the required improvements. Associated bonuses apply when successful corrective action improves the IRI of a deficient 0.1-mi. section.
- (1) **Hydraulic Concrete Pavement.** Use diamond grinding to correct deficient 0.1-mi. sections.
 - (2) **Asphalt Concrete Pavement.** For asphalt concrete pavement, the Engineer may assess a \$3,000 penalty per 0.1-mi. section instead of requiring corrective action. Use diamond grinding or other approved methods to correct deficient 0.1-mi. sections. If corrective action does not produce the required improvement, the Engineer may require continued corrective action, assess the pertinent schedule penalty if the reprofiled IRI is 95 in. per mile or less, or assess the \$3,000 penalty if the reprofiled IRI is greater than 95 in. per mile. Fog seal the aggregate exposed from diamond grinding or other corrective methods allowed.
- c. Localized Roughness.** Localized roughness will be measured using an inertial profiler in accordance with Tex-1001-S. The Engineer will determine areas of localized roughness using the average profile from both wheel paths.
- The Engineer may waive localized roughness requirements for deficiencies resulting from manholes or other similar appurtenances near the wheel path.
- (1) **Corrective Action.** When Schedule 1 or 2 is specified, use diamond grinding or other approved methods to remove localized roughness.
- When Schedule 3 is specified, use a 10-ft. straightedge to further evaluate areas with localized roughness, and use

585.4 to 585.4

diamond grinding or other approved methods to correct areas that have more than 1/8-in. variation between any 2 contacts on the straightedge.

For asphalt concrete pavements, fog-seal the aggregate exposed from diamond grinding.

Reprofile the corrected area, and provide the Engineer the results that show the corrective action was successful. For asphalt concrete pavement, if the corrective action is not successful, the Engineer will require continued corrective action or assess a localized roughness penalty.

- (2) **Localized Roughness Penalty Assessed.** For asphalt concrete pavement, in lieu of corrective action, the Engineer may assess a penalty for each occurrence of localized roughness. No more than 1 penalty will be assessed for any 5 ft. of longitudinal distance. No localized roughness penalties will be assessed in deficient 0.1-mi. sections where the Engineer elects to assess the \$3,000 penalty instead of corrective action. For Schedule 1, a localized roughness penalty of \$500 per occurrence will be assessed. For Schedule 2, a localized roughness penalty of \$250 per occurrence will be assessed. For Schedule 3, localized roughness penalties will not be assessed.

585.4. Measurement and Payment. The work performed, materials furnished, certification and recertification, traffic control for all testing, materials and work needed for corrective action, equipment, labor, tools, and incidentals will not be measured or paid for directly but will be subsidiary to pertinent Items. Sections shorter than 0.1 mi. and longer than 50 ft. will be prorated in accordance with Tex-1001-S.

Table 1
Pay Adjustment Schedules for Ride Quality

Average IRI for each 0.10 mi. of Traffic Lane (in. / mi.)	Pay Adjustment \$/0.10 mi. of Traffic Lane		
	Schedule 1	Schedule 2	Schedule 3
< 30	600	600	300
30	600	600	300
31	580	580	290
32	560	560	280
33	540	540	270
34	520	520	260
35	500	500	250
36	480	480	240
37	460	460	230
38	440	440	220
39	420	420	210
40	400	400	200
41	380	380	190
42	360	360	180
43	340	340	170
44	320	320	160
45	300	300	150
46	280	280	140
47	260	260	130
48	240	240	120
49	220	220	110
50	200	200	100
51	180	180	90
52	160	160	80
53	140	140	70
54	120	120	60
55	100	100	50
56	80	80	40
57	60	60	30
58	40	40	20
59	20	20	10
60	0	0	0
61	0	0	0

Table 1 (continued)
Pay Adjustment Schedules for Ride Quality

Average IRI for each 0.10 mi. of Traffic Lane (in./mi.)	Pay Adjustment \$/0.10 mi. of Traffic Lane		
	Schedule 1	Schedule 2	Schedule 3
62	0	0	0
63	0	0	0
64	0	0	0
65	0	0	0
66	-20	0	0
67	-40	0	0
68	-60	0	0
69	-80	0	0
70	-100	0	0
71	-120	0	0
72	-140	0	0
73	-160	0	0
74	-180	0	0
75	-200	0	0
76	-220	-20	0
77	-240	-40	0
78	-260	-60	0
79	-280	-80	0
80	-300	-100	0
81	-320	-120	0
82	-340	-140	0
83	-360	-160	0
84	-380	-180	0
85	-400	-200	0
86	-420	-220	0
87	-440	-240	0
88	-460	-260	0
89	-480	-280	0
90	-500	-300	0
91	-520	-320	0
92	-540	-340	0
93	-560	-360	0
94	-580	-380	0

Table 1 (continued)
Pay Adjustment Schedules for Ride Quality

Average IRI for each 0.10 mi. of Traffic Lane (in./mi.)	Pay Adjustment \$/0.10 mi. of Traffic Lane		
	Schedule 1	Schedule 2	Schedule 3
95	-600	-400	0
> 95	Corrective Action	Corrective Action	Not Applicable

600 ITEMS — LIGHTING, SIGNING, MARKINGS, AND SIGNALS

ITEM 610

ROADWAY ILLUMINATION ASSEMBLIES

610.1. Description.

- **Installation.** Furnish, fabricate, and erect roadway illumination assemblies.
- **Relocation.** Remove and relocate existing roadway illumination assemblies.
- **Removal.** Remove existing roadway illumination assemblies.

610.2. Materials. Provide new materials that comply with the details shown on the plans, the requirements of this Item, and the pertinent requirements of the following Items:

- Item 441, “Steel Structures”
- Item 442, “Metal for Structures”
- Item 445, “Galvanizing”
- Item 446, “Cleaning and Painting Steel”
- Item 449, “Anchor Bolts”
- Item 620, “Electrical Conductors.”

Furnish light fixtures from new materials that comply with DMS-11010, “Roadway Illumination Light Fixtures.”

Provide light fixtures from manufacturers prequalified by the Department. The Traffic Operations Division maintains a list of prequalified roadway illumination light fixture manufacturers.

Provide shop drawings of the complete assembly in accordance with the plans.

Hot-dip galvanize fabricated pole sections and associated parts in accordance with Item 445, “Galvanizing.” Punch or drill holes in steel parts or members, when allowed, before galvanizing.

Paint poles, when shown on the plans, in accordance with Item 446, “Cleaning and Painting Steel.”

610.3. Construction. Perform work in accordance with the details shown on the plans and the requirements of this Item. Sample fixtures for testing in accordance with Tex-1110-T.

Use established industry and utility safety practices when installing, relocating, or removing poles or luminaires located near overhead or

610.3 to 610.3

underground utilities. Consult with the appropriate utility company before beginning work.

Prevent scarring or marring of the poles, mast arms, and fixtures. Replace damaged components. Repair damaged galvanizing in accordance with Section 445.3.D, "Repairs." Repair damaged painted areas of a roadway illumination assembly in accordance with Item 446, "Cleaning and Painting Steel."

Stake, install, and align each roadway illumination assembly as shown on the plans. The Department may shift an assembly's location, if necessary, to secure a more desirable location or to avoid conflict with utilities.

- A. Installation.** Fabricate and install roadway illumination assembly components in accordance with the details, dimensions, and requirements shown on the plans. Do not use screw-in type foundations. Install anchor bolts and coat anchor bolt threads in accordance with Item 449, "Anchor Bolts." Erect structures after foundation concrete has attained its design strength as required on the plans and Item 421, "Hydraulic Cement Concrete." Tighten anchor bolts for poles with shoe bases in accordance with Item 449, "Anchor Bolts." Do not place grout between base plate and foundation. Test installed roadway illumination assemblies in accordance with Item 616, "Performance Testing of Lighting Systems."
- B. Relocation.** Relocate roadway illumination assembly components in accordance with the details, dimensions, and requirements shown on the plans. Do not use screw-in type foundations. Install existing structures on new foundations in accordance with Section 610.3.A, "Installation." Do not place grout between base plate and foundation. Test installed roadway illumination assemblies in accordance with Item 616, "Performance Testing of Lighting Systems."

Disconnect and remove conductors from abandoned circuits. Remove abandoned conduit or ducts to a point 6 in. below final grade.

Reconnect conduit, ducts, and conductors to be reused. Replace damaged conduit, ducts, and conductors.

Unless otherwise shown on the plans, remove abandoned concrete foundations and replace surfacing in accordance with Section 610.3.C, "Removal." Do not remove existing concrete bridge lighting brackets.

Furnish and install new internal conductors, fused and unfused connectors, and lamps. Furnish and install new transformer bases that meet AASHTO and plan requirements when relocating transformer base poles. Destroy existing transformer bases to prevent reuse.

Accept ownership of unsalvageable materials and dispose of in accordance with federal, state, and local regulations.

- C. Removal.** Remove roadway illumination assembly components in accordance with established industry and utility safety practices.

Remove transformer bases from transformer base poles. Remove luminaires and mast arms from the pole shaft. Stockpile pole shafts, mast arms, and assembly hardware at a location designated by the Department. Pole shafts, mast arms, and assembly hardware will remain Department property unless otherwise shown on the plans or directed.

Disconnect and remove conductors from abandoned circuits. Remove abandoned conduit and ducts to a point 6 in. below final grade. Destroy existing transformer bases to prevent reuse.

Remove abandoned concrete foundations to a point 2 ft. below final grade. Backfill the hole with material that is equal in composition and density to the surrounding area. Replace surfacing material with similar material to an equivalent condition. Do not remove existing concrete bridge lighting brackets.

Accept ownership of unsalvageable materials and dispose of in accordance with federal, state, and local regulations.

610.4. Measurement. This Item will be measured as each roadway illumination assembly installed, relocated, or removed.

610.5. Payment. The work performed and materials furnished in accordance with this Item and measured as provided under “Measurement” will be paid for at the unit price bid for “Install Roadway Illumination Assemblies” of the types specified, “Relocate Roadway Illumination Assemblies” of the types specified, or “Remove Roadway Illumination Assemblies” of the types specified. The Department will pay for electrical energy consumed by the lighting system.

New drilled shaft foundations will be paid for under Item 416, “Drilled Shaft Foundations.” New concrete riprap placed around foundations will be paid for under Item 432, “Riprap.” New conduit will be paid for under Item 618, “Conduit.” New conductors, except the conductors internal to the pole, will be paid for under Item 620, “Electrical Conductors.” New duct cable will be paid for under Item 622, “Duct Cable.” New ground boxes will be paid for under Item 624, “Ground Boxes.” New electrical services will be paid for under Item 628, “Electrical Services.”

613.1 to 613.3

- A. Installation.** This price is full compensation for furnishing, installing, and testing luminaires; ballasts, poles, lamps, anchor bolts, anchor plates, internal conductors, and connections; system performance testing; and equipment, labor, tools, and incidentals.
- B. Relocation.** This price is full compensation for salvaging and relocating the existing conduit, duct cable, and conductors; removing existing foundations, backfilling, and surface placement; removing, erecting, connecting, and testing illumination assemblies; furnishing and installing new anchor bolts, transformer bases, lamps, connections, and conductors; replacement of damaged components; disposal of unsalvageable material; and equipment, labor, tools, and incidentals.
- C. Removal.** This price is full compensation for removing, salvaging, disassembling, and stockpiling lighting assemblies; salvaging and relocating existing conduit and conductors; removing existing foundations; backfilling and surface placement; splicing existing conductors; disposal of unsalvageable material; and equipment, labor, tools, and incidentals.

ITEM 613

HIGH MAST ILLUMINATION POLES

613.1. Description. Furnish and install high mast illumination poles.

613.2. Materials. Provide new materials that comply with the details shown on the plans, the requirements of this Item, and the pertinent requirements of the following Items:

- Item 421, “Hydraulic Cement Concrete”
- Item 441, “Steel Structures”
- Item 442, “Metal for Structures”
- Item 445, “Galvanizing”
- Item 449, “Anchor Bolts”
- Item 618, “Conduit.”

Use alloy steel or medium-strength mild steel anchor bolts in accordance with Section 449.2.A, “Bolts and Nuts.”

613.3. Construction. Perform work in accordance with the details shown on the plans, and the requirements of this Item. Provide components that fit together properly.

A. Alternate Design. Approval must be obtained for alternate designs.

Obtain approval to eliminate the ground sleeve (with associated changes to the base plate bolt circle) or to significantly modify the access hole ring by testing a full-scale specimen of the base section. Support the specimen at the base plate on double-nutted anchor bolts. Load the specimen to produce maximum compression on the access hole ring. Provide test results that clearly demonstrate the specimen can develop the factored moment capacity (load factor of 1.38 multiplied by wind factor of 1.4 multiplied by F_b) which is approximately the full plastic bending capacity. Once a fabricator obtains approval for modified details, this approval extends to all future TxDOT projects.

- B. Shop Drawings.** Do not provide shop drawings for high mast illumination poles fabricated in accordance with this Item and the plans. Provide shop drawings for alternate designs. The submission of shop drawings is only required the first time each alternate design is used. Submit seven sets of shop drawings to the Bridge Division.
- C. Fabrication.** Fabricate and weld in accordance with Item 441, “Steel Structures”; AWS D1.1, *Structural Welding Code—Steel*; and the requirements of this Item. Match-mark pole shaft sections as shown on the plans.

Provide circumferential welds only at the top attachment and base plates. Grind or smooth the longitudinal seam welds to the same radius as contacted shaft corners for the length of the lap plus at least 6 in. at each slip joint splice. Ensure acceptable seam weld profiles for the remainder of the pole exterior. Provide full-penetration longitudinal seam welds for a length of 1.5 diameters plus at least 6 in. in outer sections at splices and at base plates. Provide 85% penetration in longitudinal seam welds at other pole sections. Provide longitudinal seam weld and fitup that will minimize acid entrapment during later galvanizing. Use at most 2 longitudinal seam welds in each section.

Hot-dip galvanize fabricated pole sections and associated parts in accordance with Item 445, “Galvanizing.” Punch or drill holes in steel parts or members, when allowed, before galvanizing. Fabrication tolerances are given in Table 1.

Table 1
Fabrication Tolerances

Part	Dimension	Tolerance (in.)
Pole shaft	Length (unassembled sections)	±1
	Shaft Thickness ¹	+0.12, -0.02
	I.D. of outside slip fitting	+1/8, -1/16
	O.D. of inside slip fitting	+1/32, -1/8
	Difference between flats or diameter	±1/4
	Straightness	1/8 in 10 ft.
	Attachment locations	±1
Assembled pole shaft	Perpendicular to base plate	1/8 in 24 in.
	Shaft centered on base plate	±1/4
	Twist in shaft ²	4° in 100 ft.
	Position of winch channel	±1/4
Base plate	Overall	±1/4
	Thickness	+1/4, -1/16
	Deviations from flat	3/16 in 24 in.
	Spacing between holes	±3/16
	Bolt hole size	±1/16
Anchor bolt templates	Outside diameter	±1/8
	Inside diameter	+1/4
	Thickness	+1/4, -1/32
	Spacing between holes	±1/16
	Bolt hole size	±1/16
Anchor bolts	Length	±1/2
	Threaded Length	±1/2
	Galvanized Length	-1/4
Misc.	Bolt hole spacing	±1/16

1. Adjust pole diameter if shaft thickness exceeds nominal thickness by 0.02 in. or more. Change the splice length for this adjustment.

2. The Department may accept an excessive twist for individual pole sections, provided the top of pole is within twist tolerance for assembled sections.

D. Installation. Stake and install high mast illumination poles as shown on the plans. The Department may shift the assembly locations, within design guidelines, where necessary to secure a more desirable location or to avoid conflict with utilities.

Use established industry and utility safety practices when installing poles located near overhead or underground utilities. Consult with the appropriate utility prior to beginning work.

Prevent scarring or marring of the poles. Repair galvanized surfaces damaged in assembly, transit, or erection; or for steel parts or members welded after galvanizing in accordance with Section 445.3.D, "Repairs."

Provide riprap around pole foundations in accordance with Item 432, "Riprap," and the details shown on the plans.

1. **Foundations.** Construct foundations for high mast illumination poles in accordance with Item 416, "Drilled Shaft Foundations," and the details shown on the plans.

Before placing concrete for the drilled shaft foundation, inspect anchor bolts to verify proper projecting length of bolts, bolt pattern, orientation of pattern, bolt alignment, and bolt galvanizing are as shown on the plans. Orient anchor bolts to provide 2 bolts on the reference line as shown on the plans. Ensure the anchor bolts are electrically bonded to the reinforcing steel as shown on the plans.

Ensure anchor bolts and templates are rigidly held in position during concrete placement. Positioning devices may be tack-welded to steel template but not to any portion of the anchor bolts. Hold conduit in place with a bar attached to the upper template and cap conduit prior to placing concrete. Ream conduit to remove burrs and sharp edges after placing concrete. Install bell ends or bushings on the conduit.

2. **Pole Assembly.** Assemble poles on blocking using a minimum of two hydraulic rams at the splices. Support the free end of the section being assembled by using hoist equipment. Apply assembly force using hydraulic rams of sufficient capacity to properly draw the sections together with little or no remaining gaps. Mark poles with permanent ink to indicate designed lap length. Ensure splices are a minimum of 90% or a maximum of 110% of the planned lap. Mark the 90% and 110% locations before assembling the pole. Obtain written approval from the Department for splices that do not meet lap tolerances prior to erecting the pole.
3. **Pole Erection.** Erect structures after foundation concrete has attained its design strength as required in the plans and Item 421,

613.4 to 614.2

“Hydraulic Cement Concrete.” Coat anchor bolt threads and tighten anchor bolts in accordance with Item 449, “Anchor Bolts.” Erect and align the poles within 12 in. of vertical. Use sufficient temporary slings, chains or wire rope to prevent unintentional separation of the pole sections. Orient poles so that a worker can see into the access hole while facing oncoming traffic.

After the high mast pole has been plumbed and all nuts are tight, tack-weld each anchor bolt nut to its washer in 2 places and tack-weld each washer to the base plate in 2 places. Tack-weld in accordance with Item 441, “Steel Structures,” the AWS D1.1 *Structural Welding Code*, and the requirements of this Item. Do not weld components to the bolt. After tack-welding, repair galvanizing damage on bolts, nuts, and washers in accordance with Item 445.3.D, “Repairs.” Do not grout between the base plate and foundation.

613.4. Measurement. This Item will be measured as each high mast illumination pole installed.

613.5. Payment. The work performed and materials furnished in accordance with this Item and measured as provided under “Measurement” will be paid for at the unit price bid for “High Mast Illumination Poles” of the wind design and height specified. This price is full compensation for furnishing, fabricating, galvanizing, assembling and erecting the pole on a foundation; anchor bolts, nuts, washers and templates; conduit, ground rods and wiring; and equipment, labor, tools, and incidentals.

New drilled shaft foundations will be paid for under Item 416, “Drilled Shaft Foundations.” New riprap will be paid for under Item 432, “Riprap.” New high mast illumination assemblies will be paid for under Item 614, “High Mast Illumination Assemblies.” New ground boxes will be paid for under Item 624, “Ground Boxes.” New electrical services will be paid for under Item 628, “Electrical Services.”

ITEM 614

HIGH MAST ILLUMINATION ASSEMBLIES

614.1. Description. Furnish and install high mast illumination assemblies.

614.2. Materials. Provide new materials that comply with the details shown on the plans, the requirements of this Item, and the pertinent requirements of the following Items:

- Item 441, “Steel Structures”
- Item 442, “Metal for Structures”
- Item 445, “Galvanizing”
- Item 446, “Cleaning and Painting Steel”
- Item 620, “Electrical Conductors.”

Galvanize the ring assemblies, assemble the ring halves in the shop to ensure proper fit, and matchmark the ring halves before shipping.

Furnish light fixtures from new materials that comply with DMS-11020, “High Mast Light Fixtures.”

Furnish other high mast components from new material that comply with DMS-11021, “High Mast Assembly Kits.”

Provide high mast ring shop drawings in accordance with the plans.

Provide high mast assembly kits and light fixtures from manufacturers prequalified by the Department. The Traffic Operations Division maintains a list of prequalified high mast assembly kit and light fixture manufacturers.

614.3. Construction. Perform work in accordance with the details shown on the plans and the requirements of this Item. Prevent scarring or marring of the ring assemblies. Replace damaged components.

Repair damaged galvanized areas of the ring assembly in accordance with Section 445.3.D, “Repairs.” Repair damaged painted areas of the ring assembly in accordance with Item 446, “Cleaning and Painting Steel.”

Before installation, sample and test fixtures in accordance with Tex-1110-T. Test installed fixtures in accordance with Item 616, “Performance Testing of Lighting Systems.”

614.4. Measurement. This Item will be measured as each high mast illumination assembly installed.

614.5. Payment. The work performed and materials furnished in accordance with this Item and measured as provided under “Measurement” will be paid for at the unit price bid for “High Mast Illumination Assemblies” of the types specified. This price is full compensation for furnishing, installing, aiming and testing all rings, ring support assemblies, lighting units, ballasts, lamps, obstruction lights, hoisting assemblies, power drive assemblies, transformers, electrical equipment, electrical cord, junction boxes and enclosures; and equipment, labor, and incidentals.

New poles for high mast illumination assemblies will be paid for under Item 613, “High Mast Illumination Poles.” New electrical services will be

616.1 to 617.2

paid for under Item 628, "Electrical Services." The Department will pay for electrical energy consumed by the lighting system.

ITEM 616

PERFORMANCE TESTING OF LIGHTING SYSTEMS

616.1. Description. Test the performance of roadway, high mast, and sign lighting systems.

616.2. Construction. Perform tests on the lighting system and tests required by Item 618, "Conduit," Item 620, "Electrical Conductors," and Item 622, "Duct Cable." Ensure that all components are properly installed.

Place the lighting system in operation for a 14-day test period. Burn the lighting system steadily for 48 hr. Then cycle the photocell or other control device for 12 days.

Pass a 14-day performance test of the lighting system.

Replace materials that are damaged or have failed before acceptance. Damaged illumination assemblies, except those damaged by the Contractor, and minor failures of lamps, ballasts, and photocells are not cause for modifying or restarting the performance test.

Replace failed or damaged existing lighting system components when caused by the Contractor.

The Department will relieve the Contractor of maintenance responsibilities upon passing a 14-day performance test of the lighting system and acceptance of the Contract.

616.3. Measurement and Payment. The work performed, materials furnished, equipment, labor, tools, and incidentals will not be measured or paid for directly, but will be subsidiary to pertinent Items. The Department will pay for electrical energy consumed by the lighting system.

ITEM 617

TEMPORARY ROADWAY ILLUMINATION

617.1. Description. Furnish and install temporary roadway illumination.

617.2. Materials. Furnish new or used material in accordance with the details shown on the plans, the requirements of this Item, and the pertinent requirements of the following Items, except for measurement and payment:

- Item 416, “Drilled Shaft Foundations”
- Item 610, “Roadway Illumination Assemblies”
- Item 613, “High Mast Illumination Poles”
- Item 614, “High Mast Illumination Assemblies”
- Item 618, “Conduit,”
- Item 620, “Electrical Conductors”
- Item 621, “Tray Cable”
- Item 622, “Duct Cable”
- Item 624, “Ground Boxes”
- Item 627, “Treated Timber Poles”
- Item 628, “Electrical Services.”

Provide utility-grade aluminum service drop cable consisting of one bare aluminum conductor, steel reinforced (ACSR), supporting 2 insulated conductors for overhead electrical work.

Material furnished by the Department and the location for pickup will be shown on the plans or as directed. Use material provided by the Department only in authorized locations on the contract for which the material was intended.

617.3. Construction. Perform work in accordance with the details shown on the plans, the NEC, the NESC, and the requirements of this Item. Test fixtures in accordance with Tex-1110-T.

Use established industry and utility safety practices when installing, relocating, or removing poles or luminaires located near overhead or underground utilities. Consult with the appropriate utility prior to beginning work.

Tension and sag overhead conductors with guys and anchors in accordance with utility distribution practices.

Install conduit and electrical conductors, tray cable, or duct cable as shown on the plans. Install ground boxes as shown on the plans. Install electrical services as shown on the plans. Install concrete foundations as shown on the plans.

Install roadway illumination assemblies, timber poles with mast arms and roadway illumination fixtures, or high mast illumination poles and assemblies as shown on the plans. The Department may shift the locations, within design guidelines, where necessary to secure a more desirable location or to avoid conflict with utilities.

Use utility grade materials for overhead electrical work. Maintain a minimum of 22 ft. clearance above the roadway for overhead electrical

617.4 to 618.1

work. Do not support overhead wiring with existing luminaire poles or breakaway luminaire poles.

Operate and maintain the temporary illumination system. Relocate temporary illumination system as shown on the plans.

Remove temporary illumination system when no longer needed. Remove abandoned concrete foundations to a point 2 ft. below final grade. Backfill the hole with material equal in composition and density to the surrounding area. Replace surfacing material with similar material to an equivalent condition.

Replace materials furnished by the Department that are scarred, battered, broken, or lost. Replace damaged temporary illumination materials intended for permanent installation. Upon completion of the work, return all Department-owned material not used during the contract, in original condition, to the location from which the material was obtained, or as directed.

617.4. Measurement. This Item will be measured by each roadway illumination fixture installed or relocated or by the month the system is operated and maintained.

617.5. Payment. The work performed and materials furnished in accordance with this Item and measured as provided under “Measurement” will be paid for at the unit price bid for “Temporary Roadway Illumination” of the type specified. This price is full compensation for installing, relocating, and removing fixtures; foundations; connection costs, electrical services, and electrical energy consumed; and materials, equipment, labor, tools, and incidentals.

Electrical energy consumed by the Contractor on an existing Department electrical service will be paid for by the Department.

Costs for utility-owned power line extensions, connection charges, meter charges, and other charges will be paid for by the Department in accordance with Article 9.5, “Force Account.” The Department will reimburse the contractor only the amount billed by the utility. No additional amount for supervision of the utility’s work will be paid.

ITEM 618

CONDUIT

618.1. Description. Furnish and place conduit.

618.2. Materials. Provide new materials that comply with the details shown on the plans, the requirements of this Item, and the pertinent requirements of Item 622, “Duct Cable.”

When specified in the plans, provide:

- rigid metal (RM) conduit that is hot-dip galvanized inside and outside with a minimum of 1.5 oz. per square foot of a zinc coating in accordance with Item 445, “Galvanizing”;
- electrical metallic tubing (EMT) and intermediate metal conduit (IMC) that is steel, galvanized on the outside, and protected on the inside with a suitable corrosion-resistant material;
- polyvinyl chloride (PVC) conduit that meets the requirements of NEMA Standard TC-2, UL 651, and the NEC;
- high-density polyethylene (HDPE) conduit without factory-installed conductors that meets the requirements of Item 622, “Duct Cable”; or
- flexible conduit that is liquid-tight.

Furnish conduit from new materials that comply with DMS-11030, “Conduit.”

Provide conduit from manufacturers prequalified by the Department. The Traffic Operations Division maintains a list of prequalified electrical conduit manufacturers.

Unless otherwise shown on the plans, fabricate fittings such as junction boxes and expansion joints from a material similar to the connecting conduit. Use watertight fittings. Do not use set screw and pressure-cast fittings. Steel compression fittings are permissible. When using HDPE conduit, provide fittings that are UL-listed as electrical conduit connectors or thermally fused using an electrically heated wound wire resistance welding method.

Use red 3-in. 4-mil polyethylene underground warning tape that continuously states “Caution Buried Electrical Line Below.”

618.3. Construction. Place conduit in accordance with the lines, grades, details, and dimensions shown on the plans or as directed. Install conduit a minimum of 18 in. deep underground unless otherwise shown on the plans. Meet the requirements of the NEC when installing conduit. Secure and support conduit placed for concrete encasement in such a manner that the alignment will not be disturbed during placement of the concrete. Cap ends of conduit and close box openings before concrete is placed.

Ream conduit to remove burrs and sharp edges. Use a standard conduit cutting die with a 3/4-in. taper per foot when conduit is threaded in the field. Fasten conduit placed on structures with conduit straps or hangers as

618.4 to 618.5

shown on the plans or as directed. Fasten conduit within 3 ft. of each box or fitting and at other locations shown on the plans or as directed. Use metal conduit clamps that are galvanized malleable or stainless steel unless otherwise shown on the plans. Use 2-hole type clamps for 2-in. diameter or larger conduit.

Fit PVC and HDPE conduit terminations with bushings or bell ends. Fit metal conduit terminations with a grounding type bushing, except conduit used for duct cable casing that does not terminate in a ground box and is not exposed at any point. Conduit terminating in threaded bossed fittings does not need a bushing. Prior to installation of conductors or final acceptance, pull a spherical template having a diameter of at least 75% of the inside diameter of the conduit through the conduit to ensure that the conduit is free from obstruction. Cap or plug empty conduit placed for future use.

Perform trench excavation and backfilling as shown on the plans or as directed and in accordance with Item 400, "Excavation and Backfill for Structures." Excavation and backfilling will be subsidiary to the installation of the conduit.

Jack and bore as shown on the plans or as directed, and in accordance with Item 476, "Jacking, Boring, or Tunneling Pipe."

Place warning tape approximately 10 in. above trenched conduit. Where existing surfacing is removed for placing conduit, repair by backfilling with material equal in composition and density to the surrounding areas and by replacing any removed surfacing, such as asphalt pavement or concrete riprap, with like material to equivalent condition. Mark conduit locations as directed.

618.4. Measurement. This Item will be measured by the foot of conduit.

This is a plans quantity measurement Item. The quantity to be paid is the quantity shown in the proposal, unless modified by Article 9.2, "Plans Quantity Measurement." Additional measurements or calculations will be made if adjustments of quantities are required.

618.5. Payment. The work performed and materials furnished in accordance with this Item and measured as provided under "Measurement" will be paid for at the unit price bid for "Conduit" of the type and size specified and the installation method specified as applicable. This price is full compensation for furnishing and installing conduit; hanging, strapping, jacking, boring, tunneling, excavating, and furnishing and placing backfill; replacing pavement structure, sod, riprap, curbs, or other surface; marking location of

conduit (when required); furnishing and installing fittings, junction boxes, and expansion joints; and equipment, labor, tools and incidentals.

Flexible conduit will not be paid for directly but will be subsidiary to pertinent Items. Unless otherwise shown on the plans, no payment will be allowed under this Item for conduit used on electrical services or in foundations.

ITEM 620

ELECTRICAL CONDUCTORS

620.1. Description. Furnish and place electrical conductors, except conductors specifically covered by other Items.

620.2. Materials. Provide new materials that comply with the details shown on the plans and the requirements of this Item. Use stranded insulated conductors that are rated for 600 volts; approved for wet locations; and marked in accordance with UL, NEC, and CSA requirements. Furnish electrical conductors in accordance with DMS-11040, "Electrical Conductors."

Provide electrical conductors from manufacturers prequalified by the Department. The Traffic Operations Division maintains a list of prequalified electrical conductor manufacturers.

Ensure that all grounding conductors size AWG No. 8 and larger are stranded, except for the grounding electrode conductor, which will be a solid conductor.

Use white insulation for grounded (neutral) conductors, except that grounded conductors AWG No. 8 and larger may be black with white tape marking at every accessible location. Do not use white insulation or marking for any other conductor except control wiring specifically shown on the plans.

Ensure that insulated grounding conductors are green except that insulated grounding conductors AWG No. 8 and larger may be black with green tape marking at every accessible location. Do not use green insulation or marking for any other conductor except control wiring specifically shown on the plans.

620.3. Construction. Splice conductors only in junction boxes, ground boxes, and transformer bases, and in poles and structures at the hand holes. Splice as shown on the plans. Do not exceed the manufacturer's

620.3 to 621.2

recommended pulling tension. Use lubricant as recommended by the manufacturer. Install conductors in accordance with the NEC.

Make insulation resistance tests on the conductors prior to making final connections, and ensure that each continuous run of insulated conductor has a minimum DC resistance of 5 megohms when tested at 1,000 volts DC. The Engineer may require verification testing of all or part of the conductor system. The Engineer will witness these verification tests. Replace conductors exhibiting an insulation resistance of less than 5 megohms.

620.4. Measurement. This Item will be measured by the foot of each single conductor.

This is a plans quantity measurement Item. The quantity to be paid is the quantity shown in the proposal, unless modified by Article 9.2, "Plans Quantity Measurement." Additional measurements or calculations will be made if adjustments of quantities are required.

620.5. Payment. The work performed and materials furnished in accordance with this Item and measured as provided under "Measurement" will be paid for at the unit price bid for "Electrical Conductors" of the types and sizes specified. This price is full compensation for furnishing, installing, and testing electrical conductors and for equipment, labor, tools, and incidentals, except that:

- conductors used in connecting the components of electrical services will be paid for under Item 628, "Electrical Services";
- conductors inside roadway illumination assemblies will be paid for under Item 610, "Roadway Illumination Assemblies"; and
- conductors used for internal wiring of equipment will not be paid for directly but will be subsidiary to pertinent Items.

ITEM 621

TRAY CABLE

621.1. Description. Furnish and install tray cable.

621.2. Materials. Provide new materials that comply with the details shown on the plans and meet the following requirements.

- Provide bare concentric-stranded soft annealed copper conductors.
- Provide individually insulated conductors with XHHW insulation and an overall polyvinyl chloride (PVC) jacket.
- Provide 3-conductor cables with black, white, and green insulation colors.

- Provide 4-conductor cable with black, white, green, and red insulation colors.
- Clearly and durably mark the outer surface of the jacket at 2-ft. maximum intervals by indent printing to show the insulation type, rating, and manufacturer.
- Assemble round conductors and provide nonhygroscopic filler to prevent flattening of cable.
- Ensure cable is suitable for use outdoors, under exposure to ultraviolet light, and in wet locations.

Furnish tray cable from new materials that comply with DMS-11050, “Tray Cable.”

Provide tray cable from manufacturers prequalified by the Department. The Traffic Operations Division maintains a list of prequalified tray cable manufacturers.

621.3. Construction. Provide an additional 5 ft. of cable coiled in each ground box when installing cable in underground conduit. Splice tray cable only at locations shown on the plans. Obtain the Engineer’s written approval for each splice. Ensure that allowed splices are watertight. Test the cables after installation and prior to any connection to the cables. Remove and replace cable testing at less than 50 megohms insulation resistance at 500 volts.

621.4. Measurement. This Item will be measured by the foot of tray cable.

This is a plans quantity measurement Item. The quantity to be paid is the quantity shown in the proposal unless modified by Article 9.2, “Plans Quantity Measurement.” Additional measurements or calculations will be made if adjustments of quantities are required.

621.5. Payment. The work performed and materials furnished in accordance with this Item and measured as provided under “Measurement” will be paid for at the unit price bid for “Tray Cable” of the types and sizes specified. This price is full compensation for furnishing and installing materials and for equipment, labor, tools, and incidentals.

ITEM 622 DUCT CABLE

622.1. Description. Furnish and install duct cable consisting of a complete assembly of conductors enclosed in a high-density polyethylene duct.

622.2 to 622.3

622.2. Materials. Provide new materials that comply with the details shown on the plans, with conductors that meet the material requirements of Item 620, "Electrical Conductors." Furnish duct cable from new materials that comply with DMS-11060, "Duct Cable."

Provide duct cable from manufacturers prequalified by the Department. The Traffic Operations Division maintains a list of prequalified duct cable manufacturers.

Furnish duct that is clearly and durably marked at maximum 10-ft. intervals with the material designation including nominal size of the duct and either the name or the trademark of the manufacturer. Mark the duct at 2-ft. intervals with sequential numbers indicating length of cable, in feet, on reel, with zero mark at the inner end.

Assemblies exhibiting evidence of conductors pulled into the duct after the duct is manufactured are not acceptable. Duct cable testing less than 50 megohms insulation resistance at 1,000 volts while still on the reel is not acceptable.

Ensure that the complete assembly is packaged on reels having sufficient diameter to prevent permanent set or damage to the duct cable. Ensure that each reel is clearly and durably marked to show the voltage rating, type of insulation, number of conductors, conductor size, length, duct size, and either the name or the trademark of the manufacturer.

Before installation, furnish written certification that all duct cable complies with the requirements of this Item and as shown on the plans.

622.3. Construction. Install duct cable by open trench methods in accordance with the NEC, except at locations where installing duct cable in conduit. Backfill the trench in accordance with Item 400, "Excavation and Backfill for Structures," except for measurement and payment. When removal of existing pavement or concrete surface is allowed, backfill with material equal in composition and density to the surrounding area and replace removed surfacing, such as asphalt pavement or concrete riprap, with like material to equivalent condition or as shown on plans.

Splicing the duct is not allowed. Make all connections in ground boxes or pole bases. Form bends with large radii to provide free movement of conductors. After installation, demonstrate that the conductors can move freely. Duct cable that has been kinked or in which the conductors cannot move freely is not acceptable. Splice conductors and test insulation in accordance with Item 620, "Electrical Conductors," except for measurement and payment.

622.4. Measurement. This Item will be measured by the foot of duct cable. This is a plans quantity measurement Item. The quantity to be paid is the quantity shown in the proposal unless modified by Article 9.2, “Plans Quantity Measurement.” Additional measurements or calculations will be made if adjustments of quantities are required.

622.5. Payment. The work performed and materials furnished in accordance with this Item and measured as provided under “Measurement” will be paid for at the unit price bid for “Duct Cable” of the types and sizes specified. This price is full compensation for furnishing and installing all duct cable; pulling through conduit; excavating and backfilling the trenches; replacing riprap, pavement structure, topsoil, sod, or other surface; testing insulation resistance; and equipment, labor, tools, and incidentals.

ITEM 624 GROUND BOXES

624.1. Description. Construct, furnish, and install ground boxes complete with lids.

624.2. Construction and Materials. Provide new materials that comply with the details shown on the plans and meet the following requirements:

- Construct cast-in-place concrete ground boxes and aprons in accordance with Item 421, “Hydraulic Cement Concrete,” and Item 440, “Reinforcing Steel.”
- Provide fabricated precast polymer concrete ground boxes, and precast concrete ground boxes that comply with DMS-11070, “Ground Boxes.”
- Construct a concrete apron, when shown on the plans, in accordance with Item 421, “Hydraulic Cement Concrete,” and Item 440, “Reinforcing Steel.”

Provide ground boxes from manufacturers prequalified by the Department. The Traffic Operations Division maintains a list of prequalified ground box manufacturers.

624.3. Measurement. This Item will be measured by each ground box complete in place.

624.4. Payment. The work performed and materials furnished in accordance with this Item and measured as provided under “Measurement” will be paid for at the unit price bid for “Ground Boxes” of the types and sizes specified. This price is full compensation for excavating and

624.4 to 625.3

backfilling; constructing, furnishing, and installing the ground boxes and concrete aprons when required; and equipment, labor, materials, tools, and incidentals.

ITEM 625

ZINC-COATED STEEL WIRE STRAND

625.1. Description. Furnish and install zinc-coated steel wire strand.

625.2. Materials. Conform to the requirements of ASTM A 475, Utilities Grade or better, Class A coating. These requirements include, but are not limited to, the properties given in Table 1. Furnish 7 wires per strand.

Table 1
Dimensions and Properties

Nominal Diameter of Strand (in.)	Nominal Diameter of Coated Wires (in.)	Approx. Weight per 1000 ft. (lb.)	Minimum Breaking Strength (lb.)	Minimum Zinc Coating Wt. Class A (oz./sq. ft.)
3/16	0.065	80	2,400	0.50
1/4	0.080	121	4,750	0.60
9/32	0.093	164	4,600	0.70
5/16	0.109	225	6,000	0.80
3/8	0.120	273	11,500	0.85
7/16	0.145	399	18,000	0.90
1/2	0.165	517	25,000	0.90

Supply new material. Remove drips, runs, sharp points, voids, and damage from the zinc coating. Samples from each roll of each diameter of strand will be taken. Replace strands failing to meet the requirements of this Item.

625.3. Construction. Install strands as shown on the plans. Splicing is not permitted.

When the strand is used as a messenger cable or span wire, ground it to the grounding conductor at each pole. Metal poles may be used as the grounding conductor. Ensure a resistance less than 1 ohm from the strand to the ground rod.

625.4. Measurement and Payment. The work performed, materials furnished, equipment, labor, tools, and incidentals will not be measured or paid for directly but will be subsidiary to pertinent Items.

ITEM 627
TREATED TIMBER POLES

627.1. Description. Furnish and install treated timber poles.

627.2. Materials. Use new treated southern pine timber poles in accordance with ANSI O5.1, "Specifications and Dimensions for Wood Poles," and the additional requirements of this Item. Use ANSI Class 5 treated timber poles for electrical services and ANSI Class 2 for all other applications, unless otherwise shown on the plans.

Ensure poles are free from pith holes at the tops and butts. Do not use poles that have a trimmed scar with a depth greater than 2 in., if the diameter is 10 in. or less, or 1/5 the pole diameter at the scar location, if the diameter is more than 10 in. Provide poles that do not deviate from straightness by more than 1 in. for each 10 ft. of length. A pole may only have sweep in 1 plane and 1 direction (single sweep), provided a straight line joining the midpoint of the pole at the butt and the midpoint of the pole at the top does not at any intermediate point pass through the external surface of the pole. Timber poles with more than 1 complete twist of spiral grain are not acceptable.

Butt slivering due to felling is permitted if the distance from the outside circumference is not less than 1/4 of the butt diameter and the height is not more than 1 ft. Use preservative treatment in accordance with AWPAC4. Furnish poles with a minimum net retention of preservative treatment in accordance with Table 1.

Mark all poles by branding in accordance with Table 2.

Table 1
Retention of Preservative Treatment

Treatment	Minimum Retention
Creosote	9.0 lb./ft. ³
Pentachlorophenol	0.45 lb./ft. ³
ACA/CCA	0.6 lb./ft. ³

**Table 2
Timber Pole Markings**

Marking	Description of Marking
PTC	Supplier’s code or trademark (for example, Pole Treating Company).
F-01	Plant location and year of treatment (for example, Forestville, 2001).
SPC	Species and preservative code (for example, southern pine, creosote).
5-35	Class-length (for example, Class 5, 35-ft. pole).

Place the bottom of the brand squarely on the face of the pole 10 ft. (plus or minus 2 in.) from the butt.

Furnish a treatment certification with every shipment of treated timber poles that includes:

- name of treating company,
- location of treating plant,
- applicable product standard (AWPA C4),
- charge number,
- date of treatment,
- contents of charge (poles),
- preservative treatment, and
- actual preservative retention values.

627.3. Construction. Use established industry and utility safety practices while installing poles located near overhead or underground utilities. Consult with the appropriate utility company prior to beginning such work.

Unless otherwise shown on the plans, set the pole a minimum depth in accordance with Table 3.

**Table 3
Pole Setting Depth**

Pole Length (ft.)	Min. Setting Depth (ft.)
25 or less	4.5
26–30	5.0
31–35	5.5
36–40	6.0
41–45	6.5
46–50	7.0

Locate timber poles as shown on the plans or as directed. Drill holes for setting poles a minimum of 1.5 diameters of the pole butt. Unless otherwise shown on the plans, set the poles plumb. Backfill the holes thoroughly by tamping in 6-in. lifts. After tamping to grade, place additional backfill material in a 6-in.-high cone around the pole to allow for settling. Use material equal in composition and density to the surrounding area. Repair surface where existing surfacing material is removed, such as asphalt pavement or concrete riprap, with like material to equivalent condition.

627.4. Measurement and Payment. The work performed, materials furnished, equipment, labor, tools, and incidentals will not be measured or paid for directly, but will be subsidiary to pertinent Items.

ITEM 628

ELECTRICAL SERVICES

628.1. Description.

- **Installation.** Furnish and install complete and independent points of electrical service.
- **Removal.** Remove electrical services.

628.2. Materials. Provide materials that comply with the details shown on the plans, the requirements of this Item, and the pertinent requirements of the following Items:

- Item 441, "Steel Structures"
- Item 445, "Galvanizing"
- Item 449, "Anchor Bolts"
- Item 618, "Conduit"
- Item 620, "Electrical Conductors"
- Item 627, "Treated Timber Poles"
- Item 656, "Foundations for Traffic Control Devices."

For the installation of electrical services, use new materials that meet the requirements of the NEC, UL, CSA, and NEMA, and that comply with DMS-11080, "Electrical Services."

Furnish electrical services from manufacturers prequalified by the Department. The Traffic Operations Division maintains a list of prequalified electrical service manufacturers.

628.3. Construction. Perform work in accordance with the details shown on the plans and the requirements of this Item.

628.4 to 628.5

- A. Installation.** Ensure components of the electrical service meet the requirements of the Electrical Detail Standards. Follow NEC and local utility company requirements when installing the electrical equipment. Coordinate the utility companies' work for providing service.
- B. Removal.** Coordinate removal with the appropriate utility company before beginning work. Before the removal of the electrical service, disconnect and isolate any existing electrical service equipment in accordance with the utility company's requirements.

Use established industry and utility safety practices while removing electrical service equipment near any overhead utilities.

Remove existing electrical service support a minimum of 2 ft. below finish grade unless otherwise shown on the plans. Repair the remaining hole by backfilling with material equal in composition and density to the surrounding area. Replace any surfacing such as asphalt pavement or concrete riprap with like material to equivalent condition.

Disconnect conductors and remove them from the conduit or duct. Cut off all protruding conduit or duct 6 in. below finish grade. Abandoned conduit or duct need not be removed unless shown on the plans.

Reconnect duct cable, conductors, and conduit to be reused when shown on the plans. Make all splices in ground boxes unless otherwise shown on the plans.

Accept ownership of unsalvageable materials, and dispose of them in accordance with federal, state, and local regulations.

628.4. Measurement. This Item will be measured by each electrical service installed or removed.

628.5. Payment. The work performed and materials furnished in accordance with this Item and measured as provided under "Measurement" will be paid for at the unit price bid for "Electrical Services" of the types specified or "Remove Electrical Services."

- A. Installation.** This price is full compensation for paying all fees, permits, and other costs; making arrangements with the utility company for all work and materials provided by the utility company; furnishing, installing, and connecting all components including poles, service supports, foundations, anchor bolts, riprap, enclosures, switches, breakers, conduit (from the service equipment including the elbow below ground), fittings, conductors (from the service equipment including the elbow below ground), brackets, bolts, hangers, and hardware; and equipment, labor, tools, and incidentals.

Costs for utility-owned power line extensions, connection charges, meter charges, and other charges will be paid for by the Department in accordance with Article 9.5, "Force Account." The Department will reimburse the contractor only the amount billed by the utility. No additional amount for supervision of the utility's work will be paid.

- B. Removal.** This price is full compensation for coordinating with the utility company to disconnect and isolate the electrical service; removing the service supports; backfilling holes; and equipment, labor, tools, and incidentals.

ITEM 634 PLYWOOD SIGNS

634.1. Description.

- **Installation.** Furnish, fabricate, and erect plywood signs. Sign supports are provided for under other items.
- **Replacement.** Replace existing signs on existing sign supports.
- **Refurbishing.** Refurbish existing plywood signs on existing sign supports.

634.2. Materials.

- A. Sign Blanks.** Furnish sign blank substrates in accordance with DMS-7100, "Plywood Sign Blanks." Use sign blanks of single panel or multi-panel construction. Unless otherwise shown on the plans, use plywood sheets of 5/8-in. thickness.
- B. Sign Face Reflectorization.** Reflectorize the sign faces with flat surface reflective sheeting. Furnish sheeting that meets DMS-8300, "Sign Face Materials." Use reflective sheeting from the same manufacturer for the entire face of a sign.
- C. Sign Messages.** Fabricate sign messages to the sizes, types, and colors shown on the plans. Use sign message material from the same manufacturer for the entire message of a sign.
- Ensure that the screened messages have clean, sharp edges and exhibit uniform color and reflectivity. Prevent runs, sags, and voids. Furnish screen inks in accordance with DMS-8300.
 - Fabricate colored, transparent film legend and reflectorized sheeting legend from materials that meet DMS-8300.
 - Fabricate nonreflectorized-sheeting legend from materials that meet DMS-8300.

634.3 to 634.3

- Furnish Type A aluminum signs required as part of a message in conformance with the plans and in accordance with Item 636, “Aluminum Signs.”

D. Hardware. Use galvanized steel, stainless steel, or dichromate-sealed aluminum for bolts, nuts, washers, lock washers, screws, and other sign assembly hardware. Use plastic or nylon washers to avoid tearing the reflective sheeting. Furnish steel or aluminum products in accordance with DMS-7120, “Sign Hardware.”

When dissimilar metals are used, select or insulate metals to prevent corrosion.

E. Sampling. The Engineer will sample in accordance with Tex-726-I.

634.3. Construction.

A. Fabrication.

1. **Sign Blanks.** Furnish sign blanks to the sizes and shapes shown on the plans. Do not use panels with a face dimension of less than 18 in. for multi-panel signs unless otherwise shown on the plans. Use 1-piece construction for 4-ft. by 8-ft. or smaller signs.

Sign face surface variation must not exceed 1/8 in. per foot.

Surface misalignment between panels in multi-panel signs must not exceed 1/16 in. at any point. Gaps between panels must not exceed 1/8 in.

Paint all edges of the sign blank, including interior edges of multi-panel signs, with a white exterior, 100% acrylic latex paint. Any commercial brand of paint may be used. Ensure that the paint does not interfere with the sheeting/substrate interface or leave any marking on the sheeting face.

2. **Sheeting Application.** Apply sheeting to sign blanks in conformance with the recommended procedures of the sheeting manufacturer. For multi-panel signs, carefully match the reflective sheeting on adjacent panels to provide uniform color, appearance, and reflectivity.

Minimize the number of splices in the sheeting. Overlap the lap-splices by at least 1/4 in. Use butt splices for Type D and Type E reflective sheeting. Provide a 1-ft. minimum dimension for any piece of sheeting. Do not splice sheeting for signs fabricated with transparent screen inks or colored transparent films.

- 3. Decals.** Code and apply sign identification decals in accordance with Item 643, “Sign Identification Decals.”
- B. Storage and Handling.** Ship, handle, and store completed sign blanks and completed signs so that corners, edges, and faces are not damaged. Damage to the sign face that is not visible when viewed at a distance of 50 ft., night or day, will be acceptable. Replace unacceptable signs.
Store all finished signs off the ground and in a vertical position until erected. Store finished signs 60 in. by 60 in. or smaller in a weatherproof building. Larger signs may be stored outside.
- C. Cleaning.** Before shop inspection, wash completed signs with a biodegradable cleaning solution acceptable to the manufacturers of the sheeting, colored transparent film, and screen ink to remove grease, oil, dirt, smears, streaks, finger marks, and other foreign material. Wash again before final inspection after erection.
- D. Installation.** Install signs as shown on the plans or as directed.
- E. Replacement.** Remove the existing signs from the existing supports and replace with new signs, including mounting hardware, as shown on the plans.
- F. Refurbishing.** Refurbish existing signs by providing and installing new messages and mounting hardware. Install new reflectorized legend and supplemental signs as shown on the plans.
- G. Unsalvageable Material.** Accept ownership of unsalvageable materials and dispose of in accordance with federal, state, and local regulations.

634.4. Measurement. Signs installed or replaced will be measured by the square foot of the sign face. Signs refurbished will be measured by each sign.

This is a plans quantity measurement Item. The quantity to be paid is the quantity shown in the proposal, unless modified by Article 9.2, “Plans Quantity Measurement.” Additional measurements or calculations will be made if adjustments of quantities are required.

634.5. Payment. The work performed and materials furnished in accordance with this Item and measured as provided under “Measurement” will be paid for at the unit price bid for “Plywood Signs,” “Replacing Existing Plywood Signs,” or “Refurbishing Plywood Signs.”

- A. Installation.** This price is full compensation for furnishing and installing new signs and hardware; fabrication of sign panels; treatment of sign panels required before application of the background materials;

636.1 to 636.2

application of the background materials and messages to the sign panels; furnishing and fabricating frames, wind beams, stiffeners, or required joint backing strips; furnishing bolts, rivets, screws, fasteners, clamps, brackets, and sign support connections; assembling and erecting the signs; preparing and cleaning the signs; and equipment, materials, labor, tools, and incidentals.

- B. Replacement.** This price is full compensation for furnishing and installing new plywood signs and hardware; removal of existing signs; fabrication of sign panels; treatment of sign panels required before application of the background materials; application of the background materials and messages to the sign panels; furnishing and fabricating frames, wind beams, stiffeners, or required joint backing strips; furnishing bolts, rivets, screws, fasteners, clamps, brackets, and sign support connections; assembling and erecting the signs; preparing and cleaning the signs; salvaging and disposal of unsalvageable material; and equipment, materials, labor, tools, and incidentals.
- C. Refurbishing.** This price is full compensation for modifying existing sign messages; removing and replacing existing route markers, reflectorized legend, or supplemental signs attached to the parent sign; preparing and cleaning the signs; furnishing sheeting and hardware; salvaging and disposal of unsalvageable material; and equipment, materials, labor, tools, and incidentals.

ITEM 636

ALUMINUM SIGNS

636.1. Description.

- **Installation.** Furnish, fabricate, and erect aluminum signs. Sign supports are provided for under other Items.
- **Replacement.** Replace existing signs on existing sign supports.
- **Refurbishing.** Refurbish existing aluminum signs on existing sign supports.

636.2. Materials.

- A. Sign Blanks.** Furnish sign blank substrates in accordance with DMS-7110, "Aluminum Sign Blanks," and in accordance with the types shown on the plans. Use single-piece sheet-aluminum substrates for Type A (small) signs and extruded aluminum substrates for Type G (ground-mounted) or Type O (overhead-mounted) signs.

- B. Sign Face ReflectORIZATION.** Reflecterize the sign faces with flat surface reflective sheeting. Furnish sheeting that meets DMS-8300, "Sign Face Materials." Use reflective sheeting from the same manufacturer for the entire face of a sign.
- C. Sign Messages.** Fabricate sign messages to the sizes, types, and colors shown on the plans. Use sign message material from the same manufacturer for the entire message of a sign.
- Ensure that the screened messages have clean, sharp edges and exhibit uniform color and reflectivity. Prevent runs, sags, and voids. Furnish screen inks in accordance with DMS-8300.
 - Fabricate colored, transparent film legend and reflectorized sheeting legend from materials that meet DMS-8300.
 - Fabricate nonreflectorized-sheeting legend from materials that meet DMS-8300.
 - Furnish Type A aluminum signs required as part of a message in conformance with the plans and in accordance with this Item.
- D. Hardware.** Use galvanized steel, stainless steel, or dichromate-sealed aluminum for bolts, nuts, washers, lock washers, screws, and other sign assembly hardware. Use plastic or nylon washers to avoid tearing the reflective sheeting. Furnish steel or aluminum products in accordance with DMS-7120, "Sign Hardware."
- When dissimilar metals are used, select or insulate metals to prevent corrosion.
- E. Sampling.** The Engineer will sample in accordance with Tex-726-I.

636.3. Construction.

A. Fabrication.

1. **Sign Blanks.** Furnish sign blanks to the sizes and shapes shown on the plans and that are free of buckles, warps, burrs, dents, cockles, or other defects. Do not splice individual extruded aluminum panel.
Complete the fabrication of sign blanks, including the cutting and drilling or punching of holes, before cleaning and degreasing. After cleaning and degreasing, ensure that the substrate does not come into contact with grease, oils, or other contaminants before the application of the reflective sheeting.
2. **Sheeting Application.** Apply sheeting to sign blanks in conformance with the recommended procedures of the sheeting

636.4 to 636.4

manufacturer. Clean and prepare the outside surface of extruded aluminum flanges in the same manner as the sign panel face.

Minimize the number of splices in the sheeting. Overlap the lap-splices by at least 1/4 in. Use butt splices for Type D and Type E reflective sheeting. Provide a 1-ft. minimum dimension for any piece of sheeting. Do not splice sheeting for signs fabricated with transparent screen inks or colored transparent films.

3. **Sign Assembly.** Assemble extruded aluminum signs in accordance with the details shown on the plans. Sign face surface variation must not exceed 1/8 in. per foot. Surface misalignment between panels in multi-panel signs must not exceed 1/16 in. at any point.
 4. **Decals.** Code and apply sign identification decals in accordance with Item 643, "Sign Identification Decals."
- B. Storage and Handling.** Ship, handle, and store completed sign blanks and completed signs so that corners, edges, and faces are not damaged. Damage to the sign face that is not visible when viewed at a distance of 50 ft., night or day, will be acceptable. Replace unacceptable signs.
- Store all finished signs off the ground and in a vertical position until erected. Store finished signs 60 in. by 60 in. or smaller in a weatherproof building. Larger signs may be stored outside.
- C. Cleaning.** Before shop inspection, wash completed signs with a biodegradable cleaning solution acceptable to the manufacturers of the sheeting, colored transparent film, and screen ink to remove grease, oil, dirt, smears, streaks, finger marks, and other foreign material. Wash again before final inspection after erection.
- D. Installation.** Install signs as shown on the plans or as directed.
- E. Replacement.** Remove the existing signs from the existing supports and replace with new signs, including mounting hardware, as shown on the plans.
- F. Refurbishing.** Refurbish existing signs by providing and installing new messages and mounting hardware. Install new reflectorized legend and supplemental signs as shown on the plans.
- G. Unsalvageable Material.** Accept ownership of unsalvageable materials and dispose of in accordance with federal, state, and local regulations.

636.4. Measurement. Signs installed or replaced will be measured by the square foot of the sign face. Signs refurbished will be measured by each sign.

This is a plans quantity measurement Item. The quantity to be paid is the quantity shown in the proposal, unless modified by Article 9.2, "Plans Quantity Measurement." Additional measurements or calculations will be made if adjustments of quantities are required.

636.5. Payment. The work performed and materials furnished in accordance with this Item and measured as provided under "Measurement" will be paid for at the unit price bid for "Aluminum Signs," "Replacing Existing Aluminum Signs," or "Refurbishing Aluminum Signs," of the type specified.

- A. Installation.** This price is full compensation for furnishing and installing new signs and hardware; fabrication of sign panels; treatment of sign panels required before application of the background materials; application of the background materials and messages to the sign panels; furnishing and fabricating frames, wind beams, stiffeners, or required joint backing strips; furnishing bolts, rivets, screws, fasteners, clamps, brackets, and sign support connections; assembling and erecting the signs; preparing and cleaning the signs; and equipment, materials, labor, tools, and incidentals.
- B. Replacement.** This price is full compensation for furnishing and installing new aluminum signs and hardware; removal of existing signs; fabrication of sign panels; treatment of sign panels required before application of the background materials; application of the background materials and messages to the sign panels; furnishing and fabricating frames, wind beams, stiffeners, or required joint backing strips; furnishing bolts, rivets, screws, fasteners, clamps, brackets, and sign support connections; assembling and erecting the signs; preparing and cleaning the signs; salvaging and disposing of unsalvageable material; and equipment, materials, labor, tools, and incidentals.
- C. Refurbishing.** This price is full compensation for modifying existing sign messages; removing and replacing existing route markers, reflectorized legend, or supplemental signs attached to the parent sign; preparing and cleaning the signs; furnishing sheeting and hardware; salvaging and disposing of unsalvageable material; and equipment, materials, labor, tools, and incidentals.

ITEM 643
SIGN IDENTIFICATION DECALS

643.1. Description. Furnish and install sign identification decals.

643.2. Materials. Meet the requirements of DMS-8315, “Sign Identification Decals.”

Figure 1 shows the sign identification decal design. Table 1 describes the information required in each row of the decal.

TxDOT												
C	Fabrication										T	1
J	F	M	A	M	J	J	A	S	O	N	D	2
	200	201	202	203	204							3
	0	1	2	3	4	5	6	7	8	9		4
Sheeting MFR – Substrate												
A	B	C	D	E	F	G	H	J	K	L	M	5a
Sheeting MFR – Legend												
A	B	C	D	E	F	G	H	J	K	L	M	5b
Installation Date												
			0	1	2	3						6
	0	1	2	3	4	5	6	7	8	9		7
J	F	M	A	M	J	J	A	S	O	N	D	8
	200	201	202	203	204							9
	0	1	2	3	4	5	6	7	8	9		10

Figure 1
Decal Design (row numbers explained in Table 1).

Table 1
Decal Description

Row Explanation	
1 -	Sign Fabricator
2 -	Month Fabricated
3 -	First 3 Digits of Year Fabricated
4 -	Last Digit of Year Fabricated
5a -	Sheeting Manufacturer - substrate
5b -	Sheeting Manufacturer - legend
6 -	Tens Digit of Date Installed
7 -	Ones Digit of Date Installed
8 -	Month Installed
9 -	First 3 Digits of Year Installed
10 -	Last Digit of Year Installed

643.3. Construction.

A. Sign Fabricator. Code the decal by punching out the following:

- “C” if fabricated by a commercial sign fabricator or “T” if fabricated by the Texas Department of Criminal Justice,
- month fabricated,
- first 3 digits of the year fabricated,
- fourth digit of the year fabricated, and
- sheeting manufacturer (codes for the sheeting manufacturers are located in the Department’s approved Material Producer List, “Sign Face Materials.”)

Affix decal to lower left corner of the sign back in an upright position.

B. Contractor. Code decal by scratching out the sign installation effective date as follows:

- first digit of the day,
- second digit of the day,
- month,
- first 3 digits of the year, and
- fourth digit of the year.

643.4. Measurement and Payment. The work performed, materials furnished, equipment, labor, tools, and incidentals will not be measured or paid for directly, but will be subsidiary to pertinent Items.

ITEM 644

SMALL ROADSIDE SIGN SUPPORTS AND ASSEMBLIES

644.1. Description.

- **Installation.** Furnish, fabricate, and erect small roadside sign assemblies consisting of the signs, sign supports, foundations, and associated mounting hardware.
- **Relocation.** Relocate existing small roadside sign assemblies, and furnish and fabricate materials as required.
- **Removal.** Remove existing small roadside sign assemblies.

644.2. Materials. Furnish all materials unless otherwise shown on the plans. Furnish only new materials. Furnish and fabricate materials in accordance with the following Items and with details shown on the plans:

- Item 421, “Hydraulic Cement Concrete”
- Item 440, “Reinforcing Steel”
- Item 441, “Steel Structures”
- Item 442, “Metal for Structures”
- Item 445, “Galvanizing”
- Item 634, “Plywood Signs”
- Item 636, “Aluminum Signs”
- Item 643, “Sign Identification Decals”
- Item 656, “Foundations for Traffic Control Devices.”

Use galvanized steel, stainless steel, dichromate sealed aluminum, or other materials shown on the plans for pipe, bolts, nuts, washers, lock washers, screws, and other sign assembly hardware. When dissimilar metals are used, select or insulate the metals to prevent corrosion.

644.3. Construction. Install foundations in accordance with Item 656, “Foundations for Traffic Control Devices.” Plumb sign supports. Do not spring or rake posts to secure proper alignment. Use established safety practices when working near underground or overhead utilities. Consult the appropriate utility company before beginning work.

A. Fabrication. Fabricate sign supports in accordance with Item 441, “Steel Structures.” Ensure that all components fit properly.

Verify the length of each post for each sign before fabrication to meet field conditions and sign-mounting heights shown on the plans.

Galvanize fabricated parts in accordance with Item 445, “Galvanizing.” Punch or drill any holes in steel parts or members before the parts or members are galvanized. Repair any steel part or member on which the

galvanizing has been damaged during assembly, transit, erection, or welding in accordance with Section 445.3.D, "Repairs."

- B. Installation.** Locate sign supports as shown on the plans, unless directed to shift the sign supports within design guidelines to secure a more desirable location or to avoid conflict with utilities and underground appurtenances. Stake sign-support locations for verification by the Engineer.

Install stub posts of the type, spacing, orientation, and projection shown on the plans. Remove and replace posts damaged during installation at the Contractor's expense.

Connect the upper post sections to the stub post sections as shown on the plans. Torque connection bolts as shown on the plans.

Attach signs to support assemblies in accordance with the plans and pertinent Items.

- C. Relocation.** Unless otherwise shown on the plans, reuse the existing supports and shorten or lengthen them as required. Obtain approval before lengthening existing supports. Furnish and install new breakaway stub posts in new foundations for relocated signs. Erect the supports on the new breakaway stub posts, and attach the signs to the supports. Attach signs to support assemblies in accordance with the plans and pertinent Items. Remove existing foundations to be abandoned in accordance with Section 644.3.D, "Removal."
- D. Removal.** Remove existing concrete foundations that are to be abandoned to 2 ft. below finish grade. Backfill the remaining hole with material equal in composition and density to the surrounding area. Replace any surfacing with like material to equivalent condition.
- E. Handling and Storage.** Handle and store existing signs or portions of signs removed so that they are not damaged. Prevent any damage to the various sign assembly components. Replace any portion of the sign damaged by the Contractor designated for reuse or salvage, including messages removed.
- Stockpile all removed sign components that will be reused or that become the property of the Department at designated locations. Accept ownership of unsalvageable materials, and dispose of them in accordance with federal, state, and local regulations.
- F. Cleaning.** After the sign has been installed, wash the entire sign with a biodegradable cleaning solution acceptable to the sheeting and screen ink manufacturers to remove dirt, grease, oil smears, streaks, finger marks, and other foreign materials.

644.4 to 647.1

644.4. Measurement. This Item will be measured as each small roadside assembly installed, removed, or relocated.

644.5. Payment. The work performed and materials furnished in accordance with this Item and measured as provided under “Measurement” will be paid for at the unit price bid for “Install Small Roadside Sign Supports and Assemblies” of the type specified, “Relocate Small Roadside Sign Supports and Assemblies” of the type specified, or “Remove Small Roadside Sign Supports and Assemblies.”

- A. Installation.** This price is full compensation for furnishing, fabricating, galvanizing, and erecting the supports; constructing foundations including concrete (when required); furnishing complete signs including sign connections and all hardware; attaching the signs to the supports; washing and cleaning the signs; and equipment, materials, labor, tools, and incidentals.
- B. Relocation.** This price is full compensation for furnishing and installing new breakaway stubs and new sign supports (when required); constructing foundations including concrete (when required); removing existing signs and related materials; new signs (when required); modifying existing sign supports; reinstallation of signs and sign assemblies; preparing and cleaning; salvaging; disposal of unsalvageable material; hauling, excavating, backfilling, and surface placement; new hardware; and equipment, materials, labor, tools, and incidentals.
- C. Removal.** This price is full compensation for removing existing sign assemblies and related materials; salvaging; disposal of unsalvageable material; hauling, excavating, backfilling, and surface placement; and equipment, materials, labor, tools, and incidentals.

ITEM 647

LARGE ROADSIDE SIGN SUPPORTS AND ASSEMBLIES

647.1. Description.

- **Installation.** Furnish, fabricate, and erect steel supports for large roadside signs.
- **Relocation.** Relocate existing large roadside sign assemblies, and furnish and fabricate materials as required.
- **Removal.** Remove existing large roadside sign assemblies.

647.2. Materials. Furnish all materials unless otherwise shown on the plans. Furnish only new materials. Furnish and fabricate materials in accordance with the following Items and with details shown on the plans:

- Item 421, “Hydraulic Cement Concrete”
- Item 440, “Reinforcing Steel”
- Item 441, “Steel Structures”
- Item 442, “Metal for Structures”
- Item 445, “Galvanizing”
- Item 643, “Sign Identification Decals.”

Use material for perforated fuse plates that does not exceed the ultimate tensile strength shown on the plans.

Use galvanized steel, stainless steel, dichromate sealed aluminum, or other materials shown on the plans for pipe, bolts, nuts, washers, lock washers, screws, and other sign-assembly hardware. When dissimilar metals are used, select or insulate the metals to prevent corrosion.

647.3. Construction. Plumb sign supports. Do not spring or rake posts to secure proper alignment. Use established safety practices when working near underground or overhead utilities. Consult with the appropriate utility company before beginning work.

A. Fabrication. Fabricate in accordance with Item 441, “Steel Structures.” Ensure that all components fit properly.

Verify the length of each post for each sign before fabrication to meet field conditions and sign-mounting heights shown on the plans. Obtain approval for any necessary field fabrication or adjustments.

Galvanize fabricated parts in accordance with Item 445, “Galvanizing.” Punch or drill any holes in steel parts or members before the parts or members are galvanized. Repair any steel part or member on which the galvanizing has been damaged during assembly, transit, erection, or welding in accordance with Section 445.3.D, “Repairs.”

B. Installation. Locate sign supports as shown on the plans, unless directed to shift the sign supports within design guidelines to secure a more desirable location or to avoid conflict with utilities and underground appurtenances. Stake the sign support locations for verification by the Engineer.

Install stub posts of the type and at the spacing, orientation, and projection shown on the plans. Secure the stub posts rigidly in position during concrete placement.

647.4 to 647.4

At the Contractor's option, sign supports may be cast in the concrete foundation as a unit. However, if installation is made with the upper post section attached, do not expose the support to traffic until the sign panel is properly affixed, unless otherwise approved.

Connect the upper post sections to the stub post sections as shown on the plans. Ensure that a flat washer is positioned on top of the bolt keeper plates between the upper and lower slip base sections, and that a flat washer is positioned under the head and nut of each connection bolt. Torque connection bolts as shown on the plans.

Attach signs to support assemblies in accordance with the plans and pertinent Items.

- C. Relocation.** Unless otherwise shown on the plans, reuse the existing supports and shorten or lengthen them as required. Furnish and install new breakaway stub posts in new foundations for relocated signs. Erect the supports on the new breakaway stub posts and attach the signs to the supports. Remove existing foundations to be abandoned in accordance with Section 647.3.D, "Removal." Attach signs to support assemblies in accordance with the plans and pertinent Items.
- D. Removal.** Remove existing concrete foundations that are to be abandoned to 2 ft. below finish grade. Backfill the remaining hole with material that is equal in composition and density to the surrounding area. Replace any surfacing with like material to equivalent condition.
- E. Handling and Storage.** Handle and store existing signs or portions of signs removed so that they are not damaged. Prevent any damage to the various sign assembly components. Replace any portion of the sign damaged by the Contractor designated for reuse or salvage, including messages removed.

Stockpile all removed sign components that will be reused or that become the property of the Department at designated locations. Accept ownership of unsalvageable materials and dispose of them in accordance with federal, state, and local regulations.

- F. Cleaning.** After the sign has been installed, wash the entire sign with a biodegradable cleaning solution acceptable to the sheeting and screen ink manufacturers to remove dirt, grease, oil smears, streaks, finger marks, and other foreign materials.

647.4. Measurement. Installation will be measured by the pound of steel sign support. Sign supports removed or relocated will be measured by each sign.

This is a plans quantity measurement Item. The quantity to be paid is the quantity shown in the proposal, unless modified by Article 9.2, "Plans Quantity Measurement." Additional measurements or calculations will be made if adjustments of quantities are required.

647.5. Payment. This work performed and materials furnished in accordance with this Item and measured as provided under "Measurement" will be paid for at the unit price bid for "Install Large Roadside Sign Supports" of the type specified, "Remove Large Roadside Sign Assemblies," or "Relocate Large Roadside Sign Assemblies."

New drilled shaft foundations will be paid for in accordance with Item 416, "Drilled Shaft Foundations." New signs will be paid for in accordance with Item 634, "Plywood Signs," or Item 636, "Aluminum Signs."

- A. Installation.** This price is full compensation for furnishing, fabricating, galvanizing, and erecting the supports and stub posts; furnishing fuse plate and slip base connections; and equipment, labor, tools, and incidentals.
- B. Relocation.** This price is full compensation for furnishing and installing new breakaway stubs, and new sign supports (when required); removing existing signs and related materials; modifying existing sign supports; reinstallation of signs and sign assemblies; preparing and cleaning the signs; hardware; salvaging and disposing of unsalvageable material; hauling, excavating, backfilling, and surface placement; and equipment, materials, labor, tools, and incidentals.
- C. Removal.** This price is full compensation for removing existing sign assemblies and related materials; salvaging; disposal of unsalvageable material; hauling, excavating, backfilling, and surface placement; and equipment, materials, labor, tools, and incidentals.

ITEM 650

OVERHEAD SIGN SUPPORTS

650.1. Description.

- **Installation.** Furnish, fabricate, and erect overhead sign supports.
- **Relocation.** Remove and relocate existing overhead sign supports.
- **Removal.** Remove existing overhead sign supports.

650.2. Materials. Provide new materials that comply with the details shown on the plans, the requirements of this Item, and the pertinent requirements of the following Items:

650.3 to 650.3

- Item 420, “Concrete Structures”
- Item 421, “Hydraulic Cement Concrete”
- Item 441, “Steel Structures”
- Item 442, “Metal for Structures”
- Item 445, “Galvanizing”
- Item 449, “Anchor Bolts”
- Item 618, “Conduit.”

Furnish alloy steel or medium-strength mild steel anchor bolts in accordance with Item 449.2.A, “Bolts and Nuts.” Furnish galvanized steel, non-corroding stainless steel, or dichromate-sealed aluminum brackets, clamps, bolts, and other hardware, in accordance with DMS-7120, “Sign Hardware.”

Reuse undamaged components when relocating an existing overhead sign structure. If such components are damaged during removal or relocation, provide new ones in accordance with the Items listed in this section, unless otherwise directed.

650.3. Construction.

- A. Alternate Design.** The Department will consider alternate designs for cantilever-type overhead sign support columns that meet the requirements of this specification and the plans.
1. Submit design calculations and a list of proposed materials, including anchor bolts, prior to submitting shop drawings. Computer-generated design parameters and calculations are not acceptable unless accompanied by appropriate supporting documentation.
 2. Determine the size of pipe to be used for the column from the appropriate Cantilever Overhead Sign Supports (COSS) or High Level Cantilever Overhead Sign Supports (HCOSS) standard plan tables for the height and span specified on the plans.
 3. Determine the maximum design parameters from the COSS or HCOSS standard plan tables for that size of pipe.
 4. Ensure that alternate designs meet or exceed these maximum design parameters.
 5. Provide top column dimensions compatible with the sign truss mounting details.
 6. Ensure that bottom diameter of the column is compatible with foundation details.

7. Limit welds to 2 longitudinal seam welds per column.
 8. Provide full penetration longitudinal seam welds within 6 in. of circumferential welds, and provide 85% penetration seam welds at other column locations.
 9. Provide longitudinal seam weld and fit-up that will minimize acid entrapment during later galvanizing.
- B. Shop Drawings.** Provide shop drawings for overhead sign supports in accordance with Item 441, “Steel Structures.” Include details for anchor bolts, sign sizes and positions, walkways, and sign lights on shop drawings.

Submit only 1 drawing for 2 or more supports of identical design and dimensions. Submit shop drawings to the Bridge Division, unless otherwise shown on the plans.

- C. Fabrication.** Fabricate and weld in accordance with Item 441, “Steel Structures”; AWS D1.1, *Structural Welding Code—Steel*; and the requirements of this Item.

For cantilever-type overhead sign support columns with diameters exceeding 30 in., one circumferential weld splice is permitted per column. Locate the splice at the height of 1/2 the column length. Provide mounting channels for the installation of sign lighting fixtures unless otherwise shown on the plans.

Conformance to plans and other approved drawings does not relieve the Contractor of responsibility for proper fit of components.

- D. Galvanizing.** Punch or drill permitted holes in steel parts or members prior to galvanizing. Hot-dip galvanize all fabricated parts in accordance with Item 445, “Galvanizing.”
- E. Galvanizing Repair.** Repair galvanizing for steel parts or members damaged in assembly, transit, or erection; for permitted field-drilled holes; or for steel parts or members welded after galvanizing in accordance with the pertinent requirements of Section 445.3.D, “Repairs.”
- F. Installation.** Stake sign support locations for verification by the Engineer. Install overhead sign support structures at verified locations. Use established industry and utility safety practices when erecting sign supports near overhead or underground utilities. Consult with appropriate utility companies prior to beginning work.

650.3 to 650.3

Construct concrete overhead sign support columns, spans, or both, as shown on the plans and in accordance with Item 420, “Concrete Structures,” except for measurement and payment.

Construct foundations for overhead sign supports in accordance with Item 416, “Drilled Shaft Foundations,” and the details shown on the plans. Orient anchor bolts as shown on the plans. Cap conduit prior to concrete placement. Ensure that the anchor bolt and template assembly is held in position during concrete placement. Use bracing attached to the upper template to ensure that conduit is held in place during concrete placement. Remove top template after the concrete achieves initial set.

Erect structures after foundation concrete has attained its design strength as required in the plans and Item 421, “Hydraulic Cement Concrete.” Coat anchor bolt threads and tighten anchor bolts in accordance with Item 449, “Anchor Bolts.” Ensure that the structure is plumb. Do not use springing or raking of columns, towers, or anchor bolts to achieve plumb.

After the overhead sign support has been plumbed and all nuts are tight, tack-weld each anchor bolt nut to its washer in 2 places and tack-weld each washer to the base plate in 2 places. Tack-weld in accordance with Item 441, “Steel Structures”; AWS D1.1, *Structural Welding Code—Steel*; and the requirements of this Item. Do not weld components to the bolt. After tack-welding, repair galvanizing damage on bolts, nuts, and washers in accordance with Section 445.3.D, “Repairs.” Do not grout between the base plate and foundation.

Ensure that sign faces are vertical.

- G. Relocation.** Disconnect and isolate electrical power supplies before removing the structure. Remove existing overhead sign structures and support towers as directed. Ensure that the structures or attached components suffer no undue stress or damage. Signs, sign walkways, mounting brackets, lights, etc., may be left on the structures, unless otherwise shown on the plans or as directed. Repair or replace damaged components as directed.

Unless otherwise shown on the plans, remove abandoned concrete foundations and replace surfacing in accordance with Section 650.3.H, “Removal.”

Move existing sign supports to locations shown on the plans or as directed. Install existing structures on new foundations in accordance with Section 650.3.F, “Installation.”

Reuse existing components, with the exception of conductors, unless otherwise directed. Furnish replacement lighting materials conforming to Section 650.2, "Materials." Accept ownership of unsalvageable materials and dispose of in accordance with federal, state, and local regulations.

- H. Removal.** Disconnect and isolate electrical power supplies before removing the structure. Remove sign panels, walkways, lighting fixtures, lighting brackets, ballast boxes, and other accessories from overhead sign supports. Remove and store items designated for reuse or salvage at locations shown on the plans or as directed. Store sign panels above the ground in a vertical position. Accept ownership of unsalvageable materials and dispose of in accordance with federal, state, and local regulations.

Unless otherwise shown on the plans, remove abandoned concrete foundations, including steel, to 2 ft. below finished grade. Cut off and remove steel protruding from the remaining concrete. Backfill with material equal in composition and density to the surrounding area, and replace surfacing with like material to an equivalent condition.

650.4. Measurement. This Item will be measured as each overhead sign support installed, relocated, or removed.

650.5. Payment. The work performed and materials furnished in accordance with this Item and measured as provided under "Measurement" will be paid for at the unit price bid for "Install Overhead Sign Supports" of the type and span lengths specified, "Relocate Existing Overhead Sign Supports," and "Remove Overhead Sign Supports." The span lengths will be the design span lengths shown on the plans rounded up to the next 5-ft. increment.

New drilled shaft foundations will be paid for under Item 416, "Drilled Shaft Foundations." New signs will be paid for under Item 636, "Aluminum Signs." New sign lights will be paid for under Item 652, "Highway Sign Lighting Fixtures." New sign walkways will be paid for under Item 654, "Sign Walkways."

- A. Installation.** This price is full compensation for furnishing, fabricating, galvanizing, assembling and erecting the overhead sign supports; furnishing and placing anchor bolts, nuts, washers and templates; furnishing concrete and reinforcing steel, construction of concrete columns and spans (when required); furnishing and placing conduit, ground rods and wiring; and equipment, materials, labor, tools, and incidentals.

652.1 to 652.3

- B. Relocation.** This price is full compensation for removing overhead sign supports; removing existing foundations; backfilling and surface placement; storing the components to be reused or salvaged; disposal of unsalvageable material; furnishing, fabricating and installing required new components; placing and securing sign supports on new foundations; furnishing and placing conduit, ground rods and wiring; loading and hauling; and equipment, materials, labor, tools, and incidentals.
- C. Removal.** This price is full compensation for removing overhead sign support components; removing the foundations; storing the components to be reused or salvaged; disposal of unsalvageable material; backfilling and surface placement; loading and hauling; and equipment, materials, tools, labor, and incidentals.

ITEM 652

HIGHWAY SIGN LIGHTING FIXTURES

652.1. Description.

- **Installation.** Furnish and install highway sign lighting fixtures.
- **Removal.** Remove highway sign lighting fixtures.

652.2. Materials. Provide new materials that comply with the details shown on the plans, the requirements of this Item, and the pertinent requirements of the following Items:

- Item 618, "Conduit"
- Item 620, "Electrical Conductors."

Furnish sign light fixtures from new materials that comply with DMS-11090, "Highway Sign Lighting Fixtures."

Provide sign light fixtures from manufacturers prequalified by the Department. The Traffic Operations Division maintains a list of prequalified sign light fixture manufacturers.

652.3. Construction.

- A. Installation.** Install lighting fixtures and associated components as shown on the plans. Test installed fixtures in accordance with Item 616, "Performance Testing of Lighting Systems." Sample fixtures for testing in accordance with Tex-1110-T.
- B. Removal.** Disconnect and isolate existing electrical power supply. Remove sign lighting fixtures without damaging materials, and salvage

when indicated on the plans. Removal includes ballast boxes and any related appurtenances no longer needed at the locations shown on the plans. Stockpile salvaged materials at the location shown on the plans or as directed. Accept ownership of unsalvageable materials and dispose of in accordance with federal, state, and local regulations.

652.4. Measurement. This Item will be measured by each highway sign lighting fixture installed or removed.

652.5. Payment. The work performed and materials furnished in accordance with this Item and measured as provided under “Measurement” will be paid for at the unit price bid for “Highway Sign Lighting Fixtures” of the types specified, or for “Remove Highway Sign Lighting Fixtures.”

New conduit will be paid for under Item 618, “Conduit.” New electrical conductors will be paid for under Item 620, “Electrical Conductors.” New electrical Services will be paid for under Item 628, “Electrical Services.” The Department will pay for electrical energy consumed by the lighting system.

- A. Installation.** This price is full compensation for furnishing, installing, and testing fixtures complete with lamps, ballasts, and ballast boxes; conduit and conductors between the fixtures and from the fixtures to the base of the tower or post supporting the sign structure; safety switches, fixture mounting bolts, hardware and internal connections; and materials, equipment, labor, tools, and incidentals.
- B. Removal.** This price is full compensation for removing various components, stockpiling, disposal of unsalvageable materials, tools, equipment, labor, and incidentals.

ITEM 654

SIGN WALKWAYS

654.1. Description.

- **Installation.** Furnish, fabricate, and erect sign walkways.
- **Removal.** Remove sign walkways.

654.2. Materials. Provide materials and construct sign walkways and handrails in accordance with the details shown on the plans, the

654.2 to 654.4

requirements of this Item, and the pertinent requirements of the following Items:

- Item 441, “Steel Structures”
- Item 445, “Galvanizing.”

654.3. Construction.

- A. Standard Designs.** Provide sign walkways as shown on the plans. Submit shop drawings in accordance with Item 441, “Steel Structures.” Submit shop drawings for the sign walkways with the shop drawings for overhead sign supports. Submit separate shop drawings for the sign walkways when installing sign walkways on existing overhead sign supports. Walkways of identical design and dimensions require only a single shop drawing submission. Unless otherwise shown on the plans, submit the shop drawings to the Bridge Division.
- B. Fabrication.** Fabricate and weld sign walkways in accordance with Item 441, “Steel Structures,” the requirements of this Item, and AWS D1.1, *Structural Welding Code—Steel*.
Conformance to the plans and other approved drawings does not relieve the Contractor of the responsibility for providing proper fit of components.
- C. Galvanizing.** Galvanize all fabricated parts in accordance with Item 445, “Galvanizing.” Punch or drill permitted holes in steel parts or members prior to galvanizing. Repair galvanizing for any steel part or member damaged in assembly, transit, or erection or for any steel part or member welded after galvanizing. Make all galvanizing repairs in accordance with Item 445, “Galvanizing.”
- D. Delivery and Installation.** Deliver each sign walkway as a complete unit or with sub-assemblies marked for field assembly. Install all fittings and hardware, or package all parts together with their associated major components during shipment. Erect the sign walkway in accordance with the details shown on the plans.
- E. Removal.** Remove sign walkways without damaging materials, and salvage them when indicated on the plans. Stockpile salvaged materials at the location shown on the plans and as directed. Accept ownership of unsalvageable materials, and dispose of them in accordance with federal, state, and local regulations.

654.4. Measurement. This Item will be measured by the foot installed or by each sign walkway removed.

This is a plans quantity measurement Item. The quantity to be paid for is the quantity shown in the proposal, unless modified by Article 9.2 “Plans Quantity Measurement.” Additional measurements or calculations will be made if adjustments of quantities are required.

654.5. Payment. The work performed and materials furnished in accordance with this Item and measured as provided under “Measurement” will be paid for at the unit price bid for “Sign Walkways” of the types and widths specified or for “Remove Sign Walkways.”

- A. Installation.** This price is full compensation for furnishing, fabricating, galvanizing, assembling, and erecting sign walkways; furnishing and placing required handrails, including connections, latches, plates, bolts, nuts, and washers; and equipment, material, tools, labor, and incidentals.
- B. Removal.** This price is full compensation for removing various components; stockpiling; disposal of unsalvageable material; and equipment, materials, tools, labor, and incidentals.

ITEM 656

FOUNDATIONS FOR TRAFFIC CONTROL DEVICES

656.1. Description. Construct concrete foundations for small roadside signs, traffic signal controllers, pedestal poles, roadside flashing beacon assemblies, and other small traffic control devices.

656.2. Materials. Ensure materials and construction methods conform to the requirements of this Item and the pertinent requirements of the following Items:

- Item 400, “Excavation and Backfill for Structures”
- Item 416, “Drilled Shaft Foundations”
- Item 420, “Concrete Structures”
- Item 421, “Hydraulic Cement Concrete”
- Item 432, “Riprap”
- Item 440, “Reinforcing Steel”
- Item 441, “Steel Structures”
- Item 442, “Metal for Structures”
- Item 445, “Galvanizing”
- Item 447, “Structural Bolting”
- Item 449, “Anchor Bolts”
- Item 618, “Conduit.”

656.3 to 656.3

Use Class A concrete for nonreinforced drilled shafts. Use Class C concrete for reinforced drilled shafts. Use Class B concrete or polymer concrete composed of borosilicate glass fiber, catalyzed polyester resin, and aggregate for traffic signal controller foundations. Use drilled shaft or galvanized steel screw-in type foundations for roadside flashing beacon assemblies.

Use reinforcing steel when required.

656.3. Construction. Stake and install foundations as shown on the plans. The Department may shift the foundation locations within design guidelines where necessary to secure a more desirable location or to avoid conflict with utilities. Use established industry and utility safety practices when working near underground or overhead utilities. Consult the appropriate utility prior to beginning work.

Hold anchor bolts in place with templates during concrete placement. Hold embedded items such as conduit or other hardware in place during concrete placement with templates or other approved means. Cap conduits before placing concrete. Ream conduit to remove burrs and sharp edges. Install bell ends or bushings on the conduit.

Carefully align foundation, posts, and anchor bolts. Do not spring or rake posts or anchor bolts.

Remove the top template after concrete has achieved initial set. Keep forms and other bracing intact until the concrete has cured at least one curing day.

Allow concrete for pedestal poles and roadside flashing beacon assemblies to cure at least 7 days before placing bases and poles on the foundation unless otherwise permitted in writing.

Allow concrete for traffic signal controller foundations and small roadside signs to cure at least 4 days before placing cabinets and posts on the foundation unless otherwise permitted.

Provide an ordinary surface finish to the concrete foundation extending above ground in accordance with Section 420.4.M, "Ordinary Surface Finish."

Place concrete riprap around the foundation in accordance with the plans.

Backfill disturbed surface with material equal in composition and density to the surrounding area. Replace surfacing material with similar material to an equivalent condition.

656.4. Measurement and Payment. The work performed, materials furnished, equipment, labor, tools, and incidentals will not be measured or paid for directly, but will be subsidiary to pertinent Items.

ITEM 658

DELINEATOR AND OBJECT MARKER ASSEMBLIES

658.1. Description.

- **Installation.** Install delineator or object maker assembly.
- **Removal.** Remove delineator or object marker assembly.

658.2. Materials. Furnish only new material in accordance with details shown in the plans. Sampling will be done by the Engineer in accordance with Tex-725-I or Tex-737-I.

A. Delineator and Object Marker Assemblies. Fabricate in accordance with the following:

- DMS-8600, "Delineators and Object Markers."
- DMS-4400, "Flexible Delineator and Object Marker Posts (Driveable and Surface-Mount-Type)."

B. Wing Channel Post. Furnish material of the size shown on the plans. Supply a completed material identification form with supporting mill test report certifying that the base metal is in accordance with the following:

- ASTM A 1011, SS Grade 50.
- ASTM A 499.

Galvanize material in accordance with Item 445, "Galvanizing."

658.3. Construction.

A. Installation. Locate delineators and object markers as shown on the plans or as directed.

Locate barrier reflectors as shown on the plans or as directed, and install in accordance with manufacturers recommendations.

Install winged channel post and flexible delineator posts to allow the reflector units and reflectorized panels to be installed at the specified height and orientation. Align post as shown or as directed.

Drive post plumb using a driving cap to prevent visible cross-section dimension distortion. Drill or drive a pilot hole when post cannot be driven without visibly distorting the cross-section dimension. Backfill pilot holes thoroughly by tamping in 6-in. lifts to grade.

658.4 to 658.5

Install surface-mount and other types of delineators and object markers in accordance with details shown on the plans.

Repair damaged galvanizing in accordance with Section 445.3.D, "Repairs." Install reflector units on wing channel posts after the posts have been erected.

- B. Removal.** Remove post assemblies without damaging materials and salvage when indicated on the plans. Remove post to a minimum of 6 in. below finish grade. Stockpile salvaged materials at the location shown on the plans or as directed. Accept ownership of unsalvageable materials and dispose of in accordance with federal, state, and local requirements.

658.4. Measurement. Installation will be measured by each delineator or object marker assembly installed. When removal is specified on the plans to be a pay item, it will be measured by each delineator or object marker assembly removed.

This is a plans quantity measurement Item. The quantity to be paid for is shown in the proposal unless modified by Article 9.2, "Plans Quantity Measurement." Additional measurements or calculations will be made if adjustments of quantities are required.

658.5. Payment. The work performed and materials furnished in accordance with this Item and measured as provided under "Measurement" will be paid for at the unit price bid for "Install Delineator Assemblies" or "Install Object Marker Assemblies" of the types and colors specified and for "Remove Delineator or Object Marker Assemblies."

- A. Installation.** This price is full compensation for furnishing, fabricating and mounting the delineator or object marker assemblies including posts, adhesive or pads for surface mount assemblies, back plates, reflector units, fastening plates, brackets, bolts, nuts and washers; and equipment, labor, tools, and incidentals.

- B. Removal.** Unless otherwise shown on the plans, removal will not be paid for directly but is subsidiary to bid items of the Contract.

When removal is shown on the plans as a bid item, this price is full compensation for removal and disposal of delineator and object marker assemblies and for equipment, labor, tools, and incidentals.

ITEM 662

WORK ZONE PAVEMENT MARKINGS

662.1. Description. Furnish, place, and maintain work zone pavement markings.

662.2. Materials. Provide thermoplastic, paint and beads, raised pavement markers, prefabricated pavement markings, temporary flexible reflective roadway marker tabs, or other approved materials for work zone pavement markings. Purchase all pavement marking materials on the open market.

Supply materials meeting:

- DMS-4200, “Pavement Markers (Reflectorized),”
 - DMS-4300, “Traffic Buttons,”
 - DMS-8240, “Permanent Prefabricated Pavement Markings,”
 - DMS-8241, “Removable Prefabricated Pavement Markings,”
 - DMS-8242, “Temporary Flexible-Reflective Road Marker Tabs,”
 - DMS-8200, “Traffic Paint,”
 - DMS-8220, “Hot Applied Thermoplastic,” and
 - DMS-8290, “Glass Traffic Beads.”
- A. Nonremovable Markings.** Use hot-applied thermoplastic or permanent prefabricated pavement markings for nonremovable markings. Paint and beads or other materials are not allowed for nonremovable markings unless shown on the plans.
- B. Removable and Short-Term Markings.** Use raised pavement markers, removable prefabricated pavement markings, temporary flexible reflective roadway marker tabs, or other approved materials for removable and short-term markings. Do not use hot-applied thermoplastic or traffic paint for removable markings. Use removable prefabricated pavement markings on the final pavement surface when the plans specify removable markings.

662.3. Construction. Apply pavement markings in accordance with the following Items:

- Item 666, “Reflectorized Pavement Markings”
 - Item 668, “Prefabricated Pavement Markings”
 - Item 672, “Raised Pavement Markers.”
- A. Placement.** Install longitudinal markings on pavement surfaces before opening to traffic. Maintain lane alignment traffic control devices and operations until markings are installed. Install markings in proper alignment in accordance with the TMUTCD and as shown on the plans.

662.3 to 662.3

Short-term markings will be allowed when standard markings (removable or nonremovable) cannot be placed before opening to traffic, if shown on the plans or directed.

When short-term markings are allowed for opening to traffic, place longitudinal standard markings no later than 14 calendar days after the placement of the surface. When inclement weather prohibits placement of markings, the 14-day period may be extended until weather permits proper application.

Place standard longitudinal markings no sooner than 3 calendar days after the placement of a surface treatment, unless otherwise shown on the plans.

Apply thermoplastic markings to a minimum thickness of 0.060 in. (60 mils). When paint and beads are allowed, apply to a minimum dry thickness of 0.012 in. (12 mils).

Place short-term markings in proper alignment with the location of the final pavement markings. Remove and replace short-term markings not in alignment at the Contractor's expense.

For removable placements, use of raised pavement markers to simulate longitudinal markings is at the Contractor's option. Use side-by-side raised pavement markers to simulate longitudinal lines wider than 4 in. Do not use raised pavement markers for words, symbols, shapes, or diagonal or transverse lines.

- B. Marking Removal.** Remove markings that conflict with succeeding markings in accordance with Item 677, "Eliminating Existing Pavement Markings and Markers." Remove short-term markings that interfere or conflict with final marking placement immediately before placing final pavement markings, unless otherwise directed. Remove the remainder of the short-term markings before final acceptance.

Leave as little evidence as possible of the marking when removing marking materials.

- C. Performance Requirements.** All markings must be visible from a distance of at least 300 ft. in daylight conditions and from a distance of at least 160 ft. in nighttime conditions, illuminated by automobile low-beam headlight. Determine visibility distances using an automobile traveling on the roadway under dry conditions.

Maintain the markings for 30 calendar days after installation. The end of the 30-day maintenance period does not relieve the contractor from the performance deficiencies requiring corrective action identified during the 30-day period. If markings fail to meet the requirements of

this Item during the 30-day period, remove and replace them at the Contractor's expense. The 30-calendar day performance requirement will begin again after replacement of the markings.

The daytime and nighttime reflected color of the markings must be distinctly white or yellow. The markings must exhibit uniform retroreflective characteristics.

662.4. Measurement. This Item will be measured by the foot or by each word, shape, symbol, or temporary flexible reflective roadway marker tab. Each stripe will be measured separately. Raised pavement markers used to simulate a marking will be measured by the foot of marking or by each raised pavement marker.

This is a plans quantity measurement Item. The quantity to be paid is the quantity shown in the proposal, unless modified by Article 9.2, "Plans Quantity Measurement." Additional measurements or calculations will be made if adjustments of quantities are required.

662.5. Payment. The work performed and materials furnished in accordance with this Item and measured as provided under "Measurement" will be paid for at the unit price bid for "Work Zone Pavement Markings" of the type and color specified and the shape, width, and size specified as applicable. This price is full compensation for furnishing, placing, maintaining, and removing work zone pavement markings and for materials, equipment, labor, tools, and incidentals.

Elimination of nonremovable markings will be paid for under Item 677, "Eliminating Existing Pavement Markings and Markers." Removal of short-term and removable markings will not be paid for directly, but will be subsidiary to this Item.

Type II work zone pavement markings (paint and beads) used as a sealer for Type I pavement markings (thermoplastic) will be paid for under this Item.

ITEM 666

REFLECTORIZED PAVEMENT MARKINGS

666.1. Description. Furnish and place reflectORIZED pavement markings.

666.2. Materials.

A. Type I Marking Materials. Furnish in accordance with DMS-8220, "Hot Applied Thermoplastic."

666.3 to 666.3

- B. Type II Marking Materials.** Furnish in accordance with DMS-8200, “Traffic Paint.”
- C. Glass Traffic Beads.** Furnish drop-on glass beads conforming to DMS-8290, “Glass Traffic Beads.”
- 1. Type I Markings.** Furnish Type III drop-on glass beads. Furnish Type II or double-drop of Type II and Type III drop-on glass beads where each type bead is applied separately in equal portions (by weight), only when specified in the plans. When furnishing a double-drop system, apply the Type III beads before applying the Type II beads.
 - 2. Type II Markings.** Furnish Type III drop-on glass beads or other beads specified on the plans.
- D. Labeling.** Use clearly marked containers that indicate color, mass, material type, manufacturer, and batch number.

666.3. Equipment.

- A. General Requirements.** Use equipment that:
- is maintained in satisfactory condition,
 - meets or exceeds the requirements of the National Board of Fire Underwriters and the RRC for this application,
 - uses an automatic bead dispenser attached to the pavement marking equipment, and
 - can provide continuous mixing and agitation of the pavement marking material.

Provide a hand-held thermometer capable of measuring the temperature of the marking material when applying Type I material.

- B. Material Placement Requirements.** Use equipment that can place:
- at least 40,000 ft. of 4-in. solid or broken markings per day at the specified thickness;
 - linear markings up to 8 in. wide in a single pass;
 - markings other than solid or broken lines;
 - a center-line and no-passing barrier-line configuration consisting of 1 broken line with 2 solid lines at the same time to the alignment, spacing, and thickness shown on the plans, for 3-line application;
 - white line from both sides;
 - lines with clean edges, uniform cross section and thickness, and reasonably square ends;

- skip lines between 10 and 10-1/2 ft., an approximate stripe-to-gap ratio of 1 to 3, and a stripe-gap cycle between 39-1/2 ft. and 40-1/2 ft., automatically;
- beads uniformly and almost instantly on the marking as the marking is being applied;
- beads uniformly during the application of all lines (each line must have an equivalent bead yield rate and embedment); and
- double-drop bead applications using both Type II and Type III beads from separate independent bead applicators, if double-drop bead application is used.

666.4. Construction. Place markings before opening to traffic unless short-term or work zone markings are allowed.

- A. General.** Obtain approval for the sequence of work and estimated daily production. On roadways already open to traffic, place markings with minimal interference to the operations of that roadway. Use traffic control as shown on the plans or as approved. Protect all markings placed under open-traffic conditions from traffic damage and disfigurement.

Establish guides to mark the lateral location of pavement markings as shown on the plans or as directed, and have guide locations verified. Use material for guides that will not leave a permanent mark on the roadway.

Apply markings on pavement that is completely dry and passes the following tests:

- Type I Marking Application—Place a sample of Type I marking material on a piece of tarpaper placed on the pavement. Allow the material to cool to ambient temperature, and then inspect the underside of the tarpaper in contact with the pavement. Pavement will be considered dry if there is no condensation on the tarpaper.
- Type II Marking Application—Place a 1-sq. ft. piece of clear plastic on the pavement, and weight down the edges. The pavement is considered dry if, when inspected after 15 min., no condensation has occurred on the underside of the plastic.

Apply markings:

- that meet the requirements of Tex-828-B,
- using widths and colors shown on the plans,
- at locations shown on the plans,

666.4 to 666.4

- in proper alignment with the guides without deviating from the alignment more than 1 in. per 200 ft. of roadway or more than 2 in. maximum,
- without abrupt deviations,
- free of blisters and with no more than 5% by area of holes or voids,
- with uniform cross section and thickness,
- with clean and reasonably square ends,
- that are reflectorized, and
- using personnel skilled and experienced with installation of pavement markings.

Remove all applied markings that are not in alignment or sequence as stated in the plans or as stated in the specifications at the Contractor's expense in accordance with Item 677, "Eliminating Existing Pavement Markings and Markers," except for measurement and payment.

B. Surface Preparation. Unless otherwise shown on the plans, prepare surfaces in accordance with this section.

- 1. Cleaning for New Asphalt Surfaces and Retracing of All Surfaces.** For new asphalt surfaces (less than 3 years old) and retracing of all surfaces, air-blast or broom the pavement surface to remove loose material, unless otherwise shown on the plans. A sealer for Type I markings is not required unless otherwise shown on the plans.
- 2. Cleaning for Old Asphalt and Concrete Surfaces (Excludes Retracing).** For old asphalt surfaces (more than 3 years old) and all concrete surfaces, clean in accordance with Item 678, "Pavement Surface Preparation for Markings," to remove curing membrane, dirt, grease, loose and flaking existing construction markings, and other forms of contamination.
- 3. Sealer for Type I Markings.** For asphalt surfaces more than 3 years old or for concrete, apply a pavement sealer before placing Type I markings on locations that do not have existing markings, unless otherwise approved. The pavement sealer may be either a Type II marking or an acrylic or epoxy sealer unless otherwise shown on the plans. Follow the manufacturer's directions for application of acrylic or epoxy sealers. When the sealer becomes dirty after placement, clean by washing or in accordance with Section 666.4.B.1, "Cleaning for New Asphalt Surfaces and Retracing of All Surfaces," as directed. Place the sealer in the same configuration and color (unless clear) as the Type I markings unless otherwise shown on the plans.

- C. Application.** Apply markings during good weather unless otherwise directed. If markings are placed at Contractor option when inclement weather is impending and the markings are damaged by subsequent precipitation, the Contractor is responsible for all costs associated with replacing the markings if required.
- 1. Type I Markings.** Place the Type I marking after the sealer cures. Apply within the temperature limits recommended by the material manufacturer. If during a spray application, operations cease for 5 min. or longer, flush the spray head by spraying marking material into a pan or similar container until the material being applied is at the recommended temperature.
Apply on clean, dry pavements passing the moisture test described in Section 666.4.A, "General," and with a surface temperature above 50°F when measured in accordance with Tex-829-B.
Apply Type I markings with a minimum thickness of:
 - 0.100 in. (100 mils) for new markings and retracing water-based markings on surface treatments involving Item 316, "Surface Treatments," or Item 318, "Hot Asphalt-Rubber Surface Treatments,"
 - 0.060 in. (60 mils) for retracing on thermoplastic pavement markings, or
 - 0.090 in. (90 mils) for all other Type I markings.
 The maximum thickness for Type I markings is 0.180 in. (180 mils). Measure thickness for markings in accordance with Tex-854-B using the tape method.
 - 2. Type II Markings.** Apply on surfaces with a minimum surface temperature of 50°F. Apply at least 20 gal. per mile on concrete and asphalt surfaces and at least 22 gal. per mile on surface treatments for a solid 4-in. line. Adjust application rates proportionally for other widths. When Type II markings are used as a sealer for Type I markings, apply at least 15 gal. per mile using Type II drop-on beads.
 - 3. Bead Coverage.** For Type I and Type II markings, provide a uniform distribution of beads across the surface of the stripe, with 40 to 60% bead embedment.
- D. Performance Period.** All markings and replacement markings must meet the requirements of Tex-828-B for at least 30 calendar days after installation. Unless otherwise directed, remove pavement markings that

666.5 to 668.1

fail to meet requirements, and replace at the Contractor's expense. Replace failing markings within 30 days of notification.

666.5. Measurement. This Item will be measured by the foot; by each word, symbol, or shape; or by any other unit shown on the plans. Each stripe will be measured separately.

This is a plans quantity measurement Item. The quantity to be paid is the quantity shown in the proposal unless modified by Article 9.2, "Plans Quantity Measurement." Additional measurements or calculations will be made if adjustments of quantities are required.

Acrylic or epoxy sealer, or Type II markings when used as a sealer for Type I markings, will be measured by the foot; by each word, symbol, or shape; or by any other unit shown on the plans.

666.6. Payment. The work performed and materials furnished in accordance with this Item and measured as provided under "Measurement" will be paid for at the unit price bid for "Pavement Sealer" of the size specified or "Reflectorized Pavement Markings" of the type and color specified and the shape, width, size, and thickness (Type I markings only) specified as applicable. This price is full compensation for materials, application of pavement markings, equipment, labor, tools, and incidentals.

Surface preparation of new concrete and asphalt concrete pavements more than 3 years old, where no stripe exists, will be paid for under Item 678, "Pavement Surface Preparation for Markings." Surface preparation of all other asphalt and old concrete pavement, except for sealing, will not be paid for directly but is subsidiary to this Item.

Work-zone pavement markings (Type II, paint and beads) used as a sealer for Type I markings (thermoplastic) will be paid for under Item 662, "Work Zone Pavement Markings."

If the Engineer requires that markings be placed in inclement weather, repair or replacement of markings damaged by the inclement weather will be paid for in addition to the original plans quantity.

ITEM 668

PREFABRICATED PAVEMENT MARKINGS

668.1. Description. Furnish and place prefabricated pavement markings.

668.2. Materials. Furnish prefabricated pavement marking materials meeting the requirements of DMS-8240, “Permanent Prefabricated Pavement Markings.”

Store all materials in a weatherproof enclosure and prevent damage during storage.

668.3. Construction.

A. General. Obtain approval for the sequence of work and estimated daily production. Before the end of each working day, remove all waste generated from the jobsite.

Establish guides to mark the lateral location of pavement markings as shown on the plans or as directed, and have guide locations verified. Use guide material that will not leave a permanent mark on the roadway.

Place pavement markings in alignment with the guides without deviating from the alignment more than 1 in. per 200 ft. of roadway or more than 2 in. maximum and with no abrupt deviations.

B. Placement Limitations. Do not place pavement-marking materials between September 30 and March 1 unless otherwise permitted.

1. Moisture. Apply material to pavement that is completely dry. Pavement will be considered dry if, on a sunny day after 15 min., no condensation occurs on the underside of a 1-ft.-square piece of clear plastic that has been placed on the pavement and weighted on the edges.

2. Temperature. Follow pavement and ambient air temperature requirements recommended by the material manufacturer. If the material manufacturer establishes no temperature requirements, do not place material if the pavement temperature is below 60°F or above 120°F.

C. Dimensions. Place markings in accordance with the color, length, width, shape, and configuration shown on the plans. Locate alignment as shown on the plans or as directed.

D. Methods. Place all material in accordance with the material manufacturer’s instructions, unless otherwise directed. In addition to the manufacturer’s instructions, place materials in accordance with the surface condition, moisture, and temperature requirements of this Item.

E. Surface Preparation. Prepare surface by any approved cleaning method that effectively removes contaminants, loose materials, and

668.4 to 668.5

conditions deleterious to proper adhesion. Abrasive or water-blast cleaning is not required unless shown on the plans. Blast-clean, when required, in accordance with Item 678, "Pavement Surface Preparation for Markings." Prepare surfaces further after cleaning by sealing or priming as recommended by the pavement marking material manufacturer or as directed. Use adhesive, when required, of the type and quality recommended by the pavement marking material manufacturer. Do not clean concrete pavement surfaces by grinding.

F. Performance Requirements.

1. **Adhesion.** Markings do not lift, shift, smear, spread, flow, or tear by traffic action.
2. **Appearance.** Markings present a neat, uniform appearance that is free of excessive adhesive, ragged edges, and irregular lines or contours.
3. **Visibility.** Markings have uniform and distinctive retroreflectance when inspected in accordance with Tex-828-B.

G. Performance Period. All markings and replacement markings must meet the requirements of this Item for at least 15 calendar days after installation. Remove all pavement markings that fail to meet requirements and replace at the Contractor's expense. Replace failing markings within 30 days of notification.

668.4. Measurement. This Item will be measured by the foot or by each word, shape, or symbol.

This is a plans quantity measurement Item. The quantity to be paid is the quantity shown in the proposal, unless modified by Article 9.2, "Plans Quantity Measurement." Additional measurements or calculations will be made if adjustments of quantities are required.

668.5. Payment. The work performed and materials furnished in accordance with this Item and measured as provided under "Measurement" will be paid for at the unit price bid for "Prefabricated Pavement Markings" of the type and color specified and the shape, width, and size specified as applicable. This price is full compensation for cleaning the pavement by any means other than required abrasive or water-blast cleaning or milling; furnishing and placing materials; and equipment, labor, tools, and incidentals.

Abrasive or water-blast cleaning and milling, when shown on the plans, will be paid for under Item 678, "Pavement Surface Preparation for Markings."

ITEM 672
RAISED PAVEMENT MARKERS

672.1. Description. Furnish and install raised pavement markers.

672.2. Materials.

- A. Markers.** Furnish raised pavement markers meeting the requirements of the following Department Material Specifications:
- **Jiggle Bar Tile.** DMS-4100, “Jiggle Bar Tile,” types I-A, II-A-A, W, and Y.
 - **Reflectorized Pavement Markers.** DMS-4200, “Pavement Markers (Reflectorized),” types I-A, I-C, I-R, II-A-A, and II-C-R.
 - **Traffic Buttons.** DMS-4300, “Traffic Buttons,” types I-A, I-C, I-R, II-A-A, II-C-R, W, and Y. Round or oval unless otherwise specified in the plans.
 - **Plowable Reflectorized Pavement Markers.** DMS-4210, “Pavement Markers (Plowable Reflectorized),” types I-A, I-C, I-R, II-A-A, and II-C-R.

The following are descriptions for each type of raised pavement marker:

- **Type I-A.** Type I-A must contain an approach face that retro-reflects amber light. The body, other than the retro-reflective face must be yellow.
 - **Type I-C.** Type I-C must contain an approach face that retro-reflects white light. The body, other than the retro-reflective face must be white or silver-white.
 - **Type I-R.** Type I-R must contain a trailing face that retro-reflects red light. The body, other than the retro-reflective face must be white or silver-white.
 - **Type II-A-A.** Type II-A-A must contain two retro-reflective faces (approach and trailing) each that retro-reflect amber light. The body, other than the retro-reflective faces, must be yellow.
 - **Type II-C-R.** Type II-C-R must contain two retro-reflective faces, an approach face that retro-reflects white light and a trailing face that retro-reflects red light. The body, other than the retro-reflective faces, must be white or silver-white.
 - **Type W.** Type W has a white body and no reflective faces.
 - **Type Y.** Type Y has a yellow body and no reflective faces.
- B. Adhesives.** Furnish adhesives that conform to the following requirements:

672.3 to 672.3

- DMS-6100, “Epoxies and Adhesives.”
- DMS-6130, “Bituminous Adhesive for Pavement Markers.”

C. **Sampling.** The Engineer will sample in accordance with Tex-729-I.

672.3. Construction. Remove existing raised pavement markers in accordance with Item 677, “Eliminating Existing Pavement Markings and Markers” (except for measurement and payment). Furnish raised pavement markers for each class from the same manufacturer. Place raised pavement markers on the new asphaltic concrete surface or surface treatment only after the new surface has aged at least 14 days.

When shown on the plans, prepare all surfaces in accordance with Item 678, “Pavement Surface Preparation for Markings.” Ensure that the bond surfaces are free of dirt, curing compound, grease, oil, moisture, loose or unsound pavement markings, and any other material that would adversely affect the adhesive bond.

Establish pavement marking guides to mark the lateral location of raised pavement markers as shown on the plans and as directed. Do not make permanent marks on the roadway for the guides.

Place raised pavement markers in proper alignment with the guides. Acceptable placement deviations are shown on the plans.

Remove raised pavement markers placed out of alignment or sequence, as shown on the plans or stated in this specification, at Contractor’s expense, in accordance with Item 677, “Eliminating Existing Pavement Markings and Markers” (except for measurement and payment).

Use the following adhesive materials for placement of raised pavement markers unless otherwise shown on the plans:

- epoxy adhesive for plowable reflectorized pavement markers.
- bituminous adhesive for jiggle bar tile; reflectorized pavement markers described in DMS-4200, “Pavement Markers (Reflectorized)”;
- epoxy adhesive for jiggle bar tile, reflectorized pavement markers described in DMS-4200, and traffic buttons on hydraulic cement concrete pavements.

Apply adhesives in sufficient quantity to:

- ensure that 100% of the bonding area of raised pavement markers is in contact with the adhesive, and
- ensure that raised pavement markers, except for plowable markers, are seated on a continuous layer of adhesive and not in contact with the pavement surface.

Apply adhesives in accordance with manufacturer's recommendations unless otherwise required by this Article. Apply bituminous adhesive only when pavement temperature and raised pavement marker temperature are 40°F or higher. Do not heat bituminous adhesive above 400°F. Agitate bituminous adhesive to ensure even heat distribution.

Machine-mix epoxy adhesive.

Furnish raised pavement markers free of rust, scale, dirt, oil, grease, moisture, and contaminants that might adversely affect the adhesive bond.

Place raised pavement markers immediately after the adhesive is applied and ensure proper bonding. Do not use adhesives or any other material that impairs the functional retro-reflectivity of the raised pavement markers.

672.4. Measurement. This Item will be measured by each raised pavement marker.

This is a plans quantity measurement Item. The quantity to be paid is the quantity shown in the proposal, unless modified by Article 9.2, "Plans Quantity Measurement." Additional measurements or calculations will be made if adjustments are required.

672.5. Payment. The work performed and materials furnished in accordance with this Item and measured as provided under "Measurement" will be paid for at the unit price bid for "Jiggle Bar Tile," "Reflectorized Pavement Marker," "Traffic Button," or "Plowable Reflectorized Pavement Marker" of the types specified. This price is full compensation for removing existing markers; furnishing and installing raised pavement markers; and equipment, materials, labor, tools, and incidentals.

ITEM 677

ELIMINATING EXISTING PAVEMENT MARKINGS AND MARKERS

677.1. Description. Eliminate existing pavement markings and raised pavement markers.

677.2. Materials. Furnish surface treatment materials in accordance with Item 300, "Asphalts, Oils, and Emulsions"; Item 302, "Aggregates for Surface Treatments"; and Item 316, "Surface Treatments." Use approved patching materials for repairing damaged surfaces.

677.3 to 677.5

Use a commercial abrasive blasting medium capable of producing the specified surface cleanliness. Use potable water when water is required.

677.3. Equipment. Furnish and maintain equipment in good working condition. Use moisture and oil traps in air compression equipment to remove all contaminants from the blasting air and prevent the deposition of moisture, oil, or other contaminants on the roadway surface.

677.4. Construction. Eliminate existing pavement markings and markers on both concrete and asphaltic surfaces in such a manner that color and texture contrast of the pavement surface will be held to a minimum. Repair damage to asphaltic surfaces, such as spalling, shelling, etc., greater than 1/4 in. in depth resulting from the removal of pavement markings and markers. Dispose of markers in accordance with federal, state, and local regulations. Use any of the following methods unless otherwise shown on the plans.

- A. Surface Treatment Method.** Apply surface treatment material at rates shown on the plans or as directed. Place a surface treatment a minimum of 2 ft. wide to cover the existing marking. Place a surface treatment, thin overlay, or microsurfacing a minimum of 1 lane in width in areas where directional changes of traffic are involved or in other areas as directed by the Engineer.
- B. Burn Method.** Use an approved burning method. For thermoplastic pavement markings or prefabricated pavement markings, heat may be applied to remove the bulk of the marking material prior to blast cleaning. When using heat, avoid spalling pavement surfaces. Sweeping or light blast cleaning may be used to remove minor residue.
- C. Blasting Method.** Use a blasting method such as water blasting, abrasive blasting, water abrasive blasting, shot blasting, slurry blasting, water-injected abrasive blasting, or brush blasting as approved. Remove pavement markings on concrete surfaces by a blasting method only.
- D. Mechanical Method.** Use any mechanical method except grinding. Flail milling is acceptable in the removal of markings on asphalt and concrete surfaces.

677.5. Measurement. This Item will be measured by each word, symbol, or shape eliminated; by the foot of marking eliminated; or by any other unit shown on the plans.

This is a plans quantity measurement item. The quantity to be paid is the quantity shown in the proposal unless modified by Article 9.2, “Plans Quantity Measurement.” Additional measurements or calculations will be made if adjustments of quantities are required.

677.6. Payment. The work performed and materials furnished in accordance with this Item and measured as provided under “Measurement” will be paid for at the unit price bid for “Eliminating Existing Pavement Markings and Markers” of the type and width as applicable. This price is full compensation for the elimination method used and equipment, materials, tools, labor, and incidentals. Removal of raised pavement markers will not be paid for directly and will be subsidiary to the pertinent bid items.

ITEM 678

PAVEMENT SURFACE PREPARATION FOR MARKINGS

678.1. Description. Prepare pavement surface areas before placement of pavement markings and raised pavement markers. Item 677, “Eliminating Existing Pavement Markings or Markers,” governs complete removal of existing markings.

678.2. Materials. Use a commercial abrasive-blasting medium capable of producing the specified surface cleanliness. Use potable water, when water is required.

678.3. Equipment. Furnish and maintain equipment in good working condition. Use moisture and oil traps in air compression equipment to remove all contaminants from the blasting air and prevent the deposition of moisture, oil, or other contaminants on the roadway surface.

678.4. Construction. Prepare pavement surface of sufficient area for the pavement markings or raised pavement markers shown on the plans. Remove all contamination and loose material. Avoid damaging the pavement surface. When existing pavement markings are present, remove loose and flaking material. Approved pavement surface preparation methods are sweeping, air blasting, flail milling, and blast cleaning unless otherwise specified on the plans.

For concrete pavement surfaces, in addition to the above, air blast after the removal of contamination or existing material and just prior to placing the stripe. Perform the air blasting with a compressor that is capable of

678.5 to 680.2

generating compressed air at a minimum of 150 cfm and 100 psi using 5/16-in. or larger hosing for the air blast.

Contaminants up to 0.5 sq. in. may remain if they are not removed by the following test, performed just before application of markings:

Step 1. Air-blast the surface to be tested, to simulate blasting during application of markings.

Step 2. Firmly press a 10-in.-long, 2-in.-wide strip of monofilament tape onto the surface, leaving approximately 2 in. free.

Step 3. Grasp the free end and remove the tape with a sharp pull.

678.5. Measurement. This Item will be measured by the foot for each width specified; by each word, shape, or symbol; or by any other unit except lump sum.

This is a plans quantity measurement Item. The quantity to be paid is the quantity shown in the proposal, unless modified by Article 9.2, "Plans Quantity Measurement." Additional measurements or calculations will be made if adjustments of quantities are required.

678.6. Payment. The work performed and materials furnished in accordance with this Item and measured as provided under "Measurement" will be paid for at the unit price bid for "Pavement Surface Preparation for Markings" of the type and width as applicable. This price is full compensation for the cleaning method used, and equipment, materials, tools, labor, and incidentals.

ITEM 680

INSTALLATION OF HIGHWAY TRAFFIC SIGNALS

680.1. Description. Install highway traffic signals.

680.2. Materials. Ensure electrical materials and construction methods conform to the current NEC and additional local utility requirements.

Furnish new materials. Ensure all materials and construction methods conform to the details shown on the plans, the requirements of this Item, and the pertinent requirements of the following Items:

- Item 610, "Roadway Illumination Assemblies"
- Item 625, "Zinc-Coated Steel Wire Strand"
- Item 627, "Treated Timber Poles"
- Item 634, "Plywood Signs"

- Item 636, “Aluminum Signs”
- Item 656, “Foundations for Traffic Control Devices.”

Provide controller assemblies that meet the requirements of DMS-11170, “Traffic Signal Controller Assembly,” and the details shown on the plans.

Provide controller assemblies from manufacturers prequalified by the Department. The Traffic Operations Division maintains a list of prequalified controller assembly manufacturers.

Provide flasher assemblies that meet the requirements of DMS-11160, “Flasher Controller Assembly,” and the details shown on the plans.

Provide flasher assemblies from manufacturers prequalified by the Department. The Traffic Operations Division maintains a list of prequalified flasher assembly manufacturers.

Sampling and testing of traffic signal controller assemblies will be done in accordance with Tex-1170-T.

680.3. Construction. Install traffic signal controller foundations in accordance with Item 656, “Foundations for Traffic Control Devices.”

A. Electrical Requirements.

1. **Electrical Services.** Make arrangements for electrical services and install and supply materials not provided by the utility company as shown on the plans. Unless otherwise shown on the plans, install 120-volt, single-phase, 60-Hz AC electrical service.
2. **Conduit.** Install conduit and fittings of the sizes and types shown on the plans. Conduit of larger size than that shown on the plans may be used with no additional compensation, providing that the same size is used for the entire length of the conduit run. Extend conduit in concrete foundations 2 to 3 in. above the concrete. Seal the ends of each conduit with silicone caulking or other approved sealant after all cables and conductors are installed.
3. **Wiring.** Unless otherwise shown on the plans, furnish stranded No. 12 AWG XHHW conductors. Install above-ground cables and conductors in rigid metal conduit, except for span wire suspended cables and conductors, drip loops, and electrical wiring inside signal poles. Make power entrances to ground-mounted controllers through underground conduit. Wire each signal installation to operate as shown on the plans.

Attach ends of wires to properly sized self-insulated solderless terminals. Attach terminals to the wires with a ratchet-type

680.3 to 680.3

compression crimping tool properly sized to the wire. Place pre-numbered identification tags of plastic or tape around each wire adjacent to wire ends in the controller and signal pole terminal blocks.

Splices will not be permitted except as shown on the plans, unless the Engineer approves each individual splice in writing. Make all allowed splices watertight.

4. **Grounding and Bonding.** Ground and bond conductors in accordance with the NEC. Ensure the resistance from the grounded point of any equipment to the nearest ground rod is less than 1 ohm.

Install a continuous bare or green insulated copper wire (equipment ground) throughout the electrical system that is the same size as the neutral conductor, but a minimum No. 8 AWG. Connect the equipment ground to all metal conduit, signal poles, controller housing, electrical service ground, ground rods, and all other metal enclosures and raceways.

Provide copper wire bonding jumpers that are a minimum No. 8 AWG.

- B. **Controller Assemblies.** Construct controller foundations in accordance with Item 656, "Foundations for Traffic Control Devices." Immediately before mounting the controller assembly on the foundation, apply a bead of silicone caulk to seal the cabinet base. Seal any space between conduit entering the controller and the foundation with silicone caulk.

Deliver the keys for the controller cabinets to the Engineer when the contract is complete.

Place the instruction manual and wiring diagrams for all equipment in the controller cabinet, inside the controller cabinet.

- C. **Timber Poles.** Furnish ANSI Class 2 timber poles other than for electrical services in accordance with details shown on the plans.
- D. **Preservation of Sod, Shrubbery, and Trees.** Replace sod, shrubbery, and trees damaged during the Contract.
- E. **Removal and Replacement of Curbs and Walks.** Obtain approval before cutting into or removing walks or curbs not shown on the plans to be removed or replaced. Restore any curbs or walks removed equivalent to original condition after work is completed, to the satisfaction of the Engineer.

- F. Sign Lighting.** Attach sign lighting to traffic signal equipment as shown on the plans.
- G. Intersection Illumination.** Construct luminaires on signal poles as shown on the plans.
- H. Test Period.** Operate completed traffic signal installations continuously for at least 30-days in a satisfactory manner. If any Contractor-furnished equipment fails during the 30-day test period, repair or replace that equipment. This repair or replacement, except lamp replacement, will start a new 30-day test period.

Replace materials that are damaged or have failed prior to acceptance. Replace failed or damaged existing signal system components when caused by the Contractor. The Department will relieve the Contractor of maintenance responsibilities upon passing a 30-day performance test of the signal system and acceptance of the contract.

680.4. Measurement. This Item will be measured as each signalized intersection controlled by a single traffic signal controller.

680.5. Payment. The work performed and materials furnished in accordance with this Item and measured as provided under “Measurement” will be paid for at the unit price bid for “Installation of Highway Traffic Signals” of the type (isolated, system, or flashing beacon) specified. This price is full compensation for furnishing, installing, and testing the completed installation, controller and associated equipment, controller foundations, luminaires, signs and sign lights mounted on signal equipment, timber poles, mounting hardware and steel wire strand; preservation and replacement of damaged sod, shrubbery and trees; removal and replacement of curbs and walks; and equipment, labor, tools, and incidentals. The Department will pay for electrical energy consumed by the traffic signal.

New drilled shaft foundations for traffic signal poles will be paid for under Item 416, “Drilled Shaft Foundations.” New conduit will be paid for under Item 618, “Conduit.” New electrical conductors will be paid for under Item 620, “Electrical Conductors.” New ground boxes will be paid for under Item 624, “Ground Boxes.” New electrical services will be paid for under Item 628, “Electrical Services.” New vehicle and pedestrian signal heads will be paid for under Item 682, “Vehicle and Pedestrian Signal Heads.” New traffic signal cables will be paid for under Item 684, “Traffic Signal Cables.” New traffic signal pole assemblies will be paid for under Item 686, “Traffic Signal Pole Assemblies (Steel).” New traffic signal detectors will be paid for under Item 688, “Pedestrian Detectors and Vehicle Loop Detectors.”

681.1 to 681.3

ITEM 681 TEMPORARY TRAFFIC SIGNALS

681.1. Description. Furnish, install, operate, maintain, reconfigure, and remove temporary traffic signals.

681.2. Work Methods. Install materials in accordance with Item 680, "Installation of Highway Traffic Signals." If signal equipment is furnished by the Department, obtain the equipment at locations shown on the plans. Provide electrical services in accordance with Item 628, "Electrical Services" (except for measurement and payment).

- A. Operation and Maintenance.** Maintain and operate the temporary traffic signals for the duration of the contract. Set signal timing as shown on the plans or as directed.
1. Designate in writing a sufficiently skilled individual responsible for maintenance and operation of the temporary traffic signals who is available to respond within a reasonable time, 24 hr. each day, unless otherwise shown on the plans.
 2. Provide backup power, when shown on the plans, for each location at all times.
- B. Reconfiguration.** Reconfigure temporary traffic signals in accordance with the plans, as directed, and within the requirements of this Item. Reconfiguration is any change made to an installed intersection, including relocation of poles, controller, or signal heads.
- C. Removal.** Remove all equipment installed for temporary traffic signals, as shown on the plans or as directed in writing.
1. Completely remove poles or other supports used for temporary traffic signals. When approved, a concrete foundation may remain 2 ft. or more below finish grade. Backfill the remaining hole with material equal in composition and density to the surrounding area. Replace any surfacing, such as asphalt pavement or concrete riprap, with like material to equivalent condition.
 2. Retain all removed temporary signal components, except for those furnished by the Department, unless otherwise shown on the plans.

681.3. Measurement. This Item will be measured by each temporary signalized intersection. A signalized intersection is a group of signals operated by a single controller.

681.4. Payment. The work performed and materials furnished in accordance with this Item and measured as provided under “Measurement” will be paid for at the unit price bid for “Temporary Traffic Signals.” This price is full compensation for picking up and returning materials furnished by the Department; installation, operation, maintenance, reconfiguration, and removal of the temporary traffic signal, foundations, electrical services, electrical energy consumed; and materials, equipment, labor, tools, and incidentals.

Electrical energy consumed by the Contractor on an existing Department electrical service will be paid for by the Department.

Costs for utility-owned power line extensions, connection charges, meter charges, and other charges will be paid for by the Department in accordance with Article 9.5, “Force Account.” The Department will reimburse the contractor only the amount billed by the utility. No additional amount for supervision of the utility’s work will be paid.

ITEM 682

VEHICLE AND PEDESTRIAN SIGNAL HEADS

682.1. Description. Furnish and install vehicle and pedestrian signal heads.

682.2. Materials. Furnish only new materials.

A. Definitions.

1. **Back Plate.** A thin strip of material extending outward from all sides of a signal head.
2. **Incandescent Optical Unit.** The lens, reflector, lamp, lamp receptacle, and associated supporting parts in a signal section.
3. **LED Optical Unit.** The LED lens and associated supporting parts in a signal section.
4. **Louver.** A device mounted to the visor restricting signal face visibility.
5. **Signal Section.** One housing case, housing door, visor, and optical unit.
6. **Signal Face.** One section or an assembly of 2 or more sections facing one direction.
7. **Signal Head.** A unidirectional face or a multidirectional assembly of faces, including back plates and louvers when required, attached at a common location on a support.

682.3 to 682.3

- B. General.** Provide vehicle signal heads in accordance with DMS-11120, “Vehicle Signal Heads.” Provide vehicle signal heads from manufacturers prequalified by the Department. The Traffic Operations Division maintains a list of prequalified vehicle signal head manufacturers.

Provide pedestrian signal heads in accordance with DMS-11130, “Pedestrian Signal Heads.” Provide pedestrian signal heads from manufacturers prequalified by the Department. The Traffic Operations Division maintains a list of prequalified pedestrian signal head manufacturers.

Supply either aluminum or polycarbonate signal head components that are of the same material and manufacturer for any one project.

Use galvanized steel, stainless steel, or dichromate sealed aluminum bolts, nuts, washers, lock washers, screws, and other assembly hardware. When dissimilar metals are used, ensure the metals are selected or insulated to prevent corrosion.

Use closed-cell silicone or closed-cell neoprene gaskets.

682.3. Construction.

- A. Assembly.** Assemble individual signal sections in multi-section faces in accordance with the manufacturer’s recommendations to form a rigid signal face. Assemble and mount signal heads as shown on the plans. Install louvers and back plates in accordance with the manufacturer’s recommendations. Close any openings in an assembled signal head with a plug of the same material and color as the head.

When installing a retrofit replacement LED traffic signal or pedestrian signal lamp unit into an existing signal housing, only remove the existing lens, reflector, and incandescent lamp; fit the new unit securely in the housing door; and connect the new housing unit to the existing electrical wiring or terminal block by means of simple connectors.

- B. Wiring.** Wire each optical unit to the terminal block located in that signal section by means of solderless wire connectors or binding screws and spade lugs. Wire all sections of a multi-section signal face to the section terminal blocks in which the traffic signal cable is terminated. Maintain the color coding on leads from the individual optical units throughout the signal head, except for the traffic signal cable. Use solderless wire connectors or binding screws and spade lugs for connections to terminal blocks. Use binding screws and spade lugs for field wiring.

682.4. Measurement. This Item will be measured by each vehicle signal section, pedestrian signal section, back plate, or louver.

682.5. Payment. The work performed and materials furnished in accordance with this Item and measured as provided under “Measurement” will be paid for at the unit price bid for “Pedestrian Signal Section,” “Vehicle Signal Section,” “Back Plate,” or “Louver,” of the types and sizes specified. This price is full compensation for furnishing, assembling, and installing the signal sections, back plates and louvers, and lenses and optics; mounting attachments; and equipment, labor, tools, and incidentals.

ITEM 684

TRAFFIC SIGNAL CABLES

684.1. Description. Furnish and install traffic signal cables.

684.2. Materials. Provide polyethylene-jacketed multi-conductor cables in accordance with details shown on the plans. Individual conductors must be copper with polyethylene insulation rated for 600 volts. Furnish new materials. Provide traffic signal cables in accordance with DMS-11110, “Traffic Signal Cables.”

- A. Type A Cables.** Use Type A cables meeting the requirements of IMSA 20-1 for underground conduit installation or for aerial cable supported by a messenger.
- B. Type B Cables.** Use Type B cables meeting the requirements of IMSA 20-3 as the integral messenger cable for aerial installations.
- C. Type C Cables.** Use Type C cables meeting the requirements of IMSA 50-2 for loop detector lead-in installations consisting of 2-conductor shielded cable.
- D. Types A and B Cable Materials.** Provide the following materials for Type A and B cables:
 - Use the size and number of conductors shown on the plans. Unless otherwise shown on the plans, use conductors consisting of 7 copper strands.
 - Ensure color coding of conductors and sequence for cables are in compliance with Table 1. Base color is the insulation color. Tracer color is the colored stripe that is part of or is firmly adhered to the insulation surface for the full length of the conductor.
 - Ensure 2-conductor cable is of the round twisted type with fillers used where necessary to form a round cable.

684.2 to 684.2

- For cables with more than 2 conductors, ensure individual conductors are laid up symmetrically in layers with fillers used when necessary, to produce a uniform assembly of conductors with a firm compact cylindrical core.
- Ensure fillers are a non-metallic, moisture-resistant, non-wicking material.
- Supply conductor assemblies that are covered with a wrapping of a moisture-resistant tape applied to overlap at least 10% of the tape width.
- Ensure that the taped conductor assembly is covered with a tightly fitting black polyethylene jacket that is smooth and free from holes, splits, blisters, and any other imperfections.
- Supply cables that clearly show the name of the manufacturer and the IMSA specification number applied at approximate 2-ft. intervals to the outer surface of the jacket by indent printing.

**Table 1
Conductor Color and Sequence for Cables**

Conductor No.	Base Color	Tracer Color
1	Black	
2	White	
3	Red	
4	Green	
5	Orange	
6	Blue	
7	White	Black
8	Red	Black
9	Green	Black
10	Orange	Black
11	Blue	Black
12	Black	White
13	Red	White
14	Green	White
15	Blue	White
16	Black	Red
17	White	Red
18	Orange	Red
19	Blue	Red
20	Red	Green
21	Orange	Green

- E. Additional Requirements for Type B Cable Materials.** Additional material requirements particular to Type B cable are as follows:
- Ensure cables consisting of 5 or more conductors have a 0.25-in. nominal diameter messenger. For the messenger, use Class A galvanized Extra High Strength Steel Strand with 3 or 7 wires.
 - A solid strand messenger with 0.134-in. diameter may be used for cables with less than 5 conductors.
 - To provide corrosion protection, ensure the messenger strand is coated and the interstices are flooded with a rubber asphalt compound or equivalent.
 - Ensure the integral messenger and conductors are enclosed in the jacket forming a cross section similar to a figure 8.
- F. Type C Cable Materials.** Use the following materials for Type C cables:
- Unless otherwise shown on the plans, use No. 14 AWG insulated conductors with concentric stranding with black insulation on 1 of the 2 conductors and clear insulation on the other conductor. Ensure conductors have a minimum of 2 twists per foot within the cable.
 - Use cables that have 100% shield coverage utilizing aluminum bonded to a Mylar film. Ensure the drain wire is stranded tinned copper, 2 AWG sizes less than the conductor, and in continuous contact with the aluminum side of the shield material.
 - Ensure the jacket is black polyethylene.
 - Use cables that legibly show the name of the manufacturer and the IMSA specification number applied at approximate 2-ft. intervals on a tape under the outer jacket.
- G. Sampling.** The Engineer may take samples from each roll of each size of cable for establishing conformity to IMSA. The samples will be at least 3 ft. in length. Replace any cable failing to meet IMSA requirements.

684.3. Construction. For each cable run in underground conduit, coil an extra 5 ft. of cable in each ground box.

Splices are not permitted in Type A and B cables unless shown on the plans or approved by the Engineer in writing. Ensure that splices are watertight.

Make splices between Type C cable and loop detector wires only in the ground box near the loop the cable is servicing. Use non-corrosive solder for splices. Ground the drain wire of Type C cable to earth ground only at

684.4 to 685.2

the controller or detector cabinet. Ensure the resistance from the drain wire to the ground rod is less than 1 ohm.

Test the cables after installation and prior to any connection to the cables. Cables testing less than 50 megohms insulation resistance at 500 volts will be rejected.

684.4. Measurement. This Item will be measured by the foot of traffic signal cables.

This is a plans quantity measurement Item. The quantity to be paid is the quantity shown in the proposal, unless modified by Article 9.2, "Plans Quantity Measurement." Additional measurements or calculations will be made if adjustments of quantities are required.

684.5. Payment. The work performed and materials furnished in accordance with this Item and measured as provided under "Measurement" will be paid for at the unit price bid for "Traffic Signal Cables" of the types and sizes specified. This price is full compensation for furnishing and installing materials and for equipment, labor, tools, and incidentals, except as shown below.

Cables inside traffic signal pole assemblies will be paid for under this Item.

Cables used for inside signal heads and controllers or for coils in ground boxes, pole bases, and on span wires will not be paid for directly but will be subsidiary to pertinent Items.

ITEM 685

ROADSIDE FLASHING BEACON ASSEMBLIES

685.1. Description.

- **Installation.** Furnish, fabricate, and erect roadside flashing beacon assemblies.
- **Relocation.** Remove and relocate existing roadside flashing beacon assemblies.
- **Removal.** Remove existing roadside flashing beacon assemblies.

685.2. Materials. Furnish new materials in accordance with the following Items and with details shown on the plans:

- Item 441, “Steel Structures”
- Item 442, “Metal for Structures”
- Item 445, “Galvanizing”
- Item 449, “Anchor Bolts”
- Item 656, “Foundations for Traffic Control Devices.”

Provide flasher controller assemblies in accordance with DMS-11160, “Flasher Controller Assembly.”

Provide flasher assemblies from manufacturers prequalified by the Department. The Traffic Operations Division maintains a list of prequalified flasher assembly manufacturers.

Provide pedestal pole bases in accordance with DMS-11140, “Pedestal Pole Base.”

Provide pedestal pole bases from manufacturers prequalified by the Department. The Traffic Operations Division maintains a list of prequalified pedestal pole base manufacturers.

When shown on the plans, provide solar powered flasher controller assemblies in accordance with DMS-11150, “Solar Power Flasher Controller Assembly.”

Provide solar powered flasher controller assemblies from manufacturers prequalified by the Department. The Traffic Operations Division maintains a list of prequalified solar-powered flasher controller assembly manufacturers.

Provide shop drawings for the complete assembly. Refer to the appropriate ASTM or Aluminum Association designation for all materials shown in submittals. Use the fabricator’s model number to identify the base in all tests, drawings, documentation, and other references.

685.3. Construction. For installation and relocation, install foundations in accordance with Item 656, “Foundations for Traffic Control Devices.”

- A. Fabrication.** Provide poles and bases in accordance with Item 687, “Pedestal Pole Assemblies.” Provide mild steel anchor bolts in accordance with Item 449, “Anchor Bolts.” Use galvanized bolts, nuts, and washers.
- B. Galvanizing.** Galvanize all fabricated parts in accordance with Item 445, “Galvanizing.” Repair galvanizing for any steel part or member damaged in assembly, transit, or erection, or for any steel part or member welded after galvanizing, in accordance with Item 445.3.D, “Repairs.”

685.4 to 685.5

- C. Installation.** Install roadside flashing beacon assemblies at the locations shown on the plans or as directed. Unless otherwise shown on the plans, stake the assembly locations for verification by the Engineer.

Install pole, breakaway base, connectors, wiring, signal beacons, sign, and foundation as shown on the plans or as directed. Install the flasher controller assembly on the electrical service pole. Install watertight breakaway electrical fuse holders in all line and neutral conductors at the breakaway base.

Use established industry and utility safety practices to erect assemblies near overhead or underground utilities. Consult with the appropriate utility company prior to beginning such work.

- D. Relocation.** Disconnect and isolate the electrical power supply prior to removal of the assembly. Remove existing assembly as directed. Unless otherwise directed, salvage existing components such as sign, beacons, pole, and base. Repair or replace lost or damaged components as directed.

Relocate existing assembly to the location shown on the plans or as directed. Install existing assembly at new foundations in accordance with Section 685.3.C, "Installation." Remove existing foundations in accordance with Section 685.3.E, "Removal." Accept ownership of unsalvageable materials and dispose of in accordance with federal, state, and local regulations.

- E. Removal.** Disconnect and isolate existing electrical power supplies prior to removal of the assembly. Remove existing sign panel, beacons, pole, and base from existing assembly. Store items to be reused or salvaged without damaging. Store sign panels above the ground in a vertical position at locations shown on the plans or as directed. Accept ownership of unsalvageable materials and dispose of in accordance with federal, state, and local regulations.

Unless otherwise shown on the plans, remove abandoned foundations, including steel, to 2 ft. below the finished grade. Backfill with material equal in composition and density to the surrounding area, and replace any surfacing, such as asphalt pavement or concrete riprap, with like material to equivalent condition.

685.4. Measurement. This Item will be measured by each installed, relocated, or removed roadside flashing beacon assembly.

685.5. Payment. The work performed and materials furnished in accordance with this Item and measured as provided under "Measurement"

will be paid for at the unit price bid for “Install Roadside Flashing Beacon Assemblies,” “Relocate Roadside Flashing Beacon Assemblies,” or “Remove Roadside Flashing Beacon Assemblies.” The Department will pay for electrical energy consumed by the roadside flashing beacon.

New electrical services will be paid for under Item 628, “Electrical Services.” New signs will be paid for under Item 634, “Plywood Signs,” or Item 636, “Aluminum Signs.” New signal heads will be paid for under Item 682, “Vehicle and Pedestrian Signal Heads.”

- A. Installation.** This price is full compensation for furnishing, fabricating, galvanizing, assembling, and erecting the roadside flashing beacon assemblies; foundations; furnishing and placing anchor bolts, nuts, washers, and templates; controller; and equipment, materials, labor, tools, and incidentals.
- B. Relocation.** This price is full compensation for removing the roadside flashing beacon assemblies; removing existing foundations; installing new foundations; furnishing, fabricating, and installing any new components as required and replacing the assembly on its new foundations with all manipulations and electrical work; controller; salvaging; disposal of unsalvageable material; loading and hauling; and equipment, material, labor, tools, and incidentals.
- C. Removal.** This price is full compensation for removing the various roadside flashing beacon assemblies components; removing the foundations; storing the components to be reused or salvaged; disposal of unsalvageable material; backfilling and surface placement; loading and hauling; and equipment, materials, tools, labor, and incidentals.

ITEM 686

TRAFFIC SIGNAL POLE ASSEMBLIES (STEEL)

686.1. Description.

- **Installation.** Fabricate, furnish, and erect steel cantilever traffic signal pole assemblies.
- **Relocation.** Remove and relocate steel cantilever traffic signal pole assemblies.

686.2. Materials. Provide new materials that comply with the details shown on the plans, the requirements of this Item, and the pertinent requirements of the following Items:

- Item 421, “Hydraulic Cement Concrete”
- Item 441, “Steel Structures”

686.3 to 686.3

- Item 442, “Metal for Structures”
- Item 445, “Galvanizing”
- Item 449, “Anchor Bolts.”

Furnish alloy steel or medium-strength mild steel anchor bolts in accordance with Item 449.2.A, “Bolts and Nuts.”

686.3. Construction.

- A. Standard Design.** Alternate designs are not acceptable. Deviations that affect the basic structural behavior of the pole are considered to be alternate designs. For deviations that do not affect the basic structural behavior of the pole, submit 7 sets of shop drawings to the Bridge Division for approval.
- B. Fabrication.** Fabricate and weld in accordance with Item 441, “Steel Structures”; AWS D1.1, *Structural Welding Code—Steel*; and the requirements of this Item. Fabrication tolerances are given in Table 1.

**Table 1
Fabrication Tolerances**

Part	Dimension	Tolerance (in.)
Pole and mast arm shaft	Length	±1
	Thickness	+0.12, -0.02
	Difference between flats or diameter	±3/16
	Straightness	1/8 in 10 ft.
	Attachment locations	±1
Base and mast arm mounting plates	Overall	±3/16
	Thickness	+1/4, -0
	Deviations from flat	3/16 in 24 in.
	Spacing between holes	±1/8
	Bolt hole size	±1/16
Anchor bolts	Length	±1/2
	Threaded Length	±1/2
	Galvanized Length	-1/4
Assembled shafts	Angular Orientation	1/16 in 12 in. ¹
	Centering	±3/16
	Twist	3° in 50 ft.

1. 1/8 in 12 in. between mounting plates and between mounting plates and base plates.

Provide properly fitting components. Provide round or octagonal shafts for poles and mast arms tapered as shown on the plans. Fabricate mast arms straight in the unloaded condition unless otherwise shown on the

plans. The Department will accept bolted slip joints overlapping by at least 1.5 diameters in mast arms 40 ft. and longer.

Provide circumferential welds only at the ends of the shafts. Provide no more than 2 longitudinal seam welds in shaft sections. Grind or smooth the exterior of longitudinal seam welds to the same appearance as other shaft surfaces. Ensure 100% penetration within 6 in. of circumferential base welds and at least 60% penetration at other locations along the longitudinal seam welds. Use a welding technique that minimizes acid entrapment during later galvanizing. Hot-dip galvanize all fabricated parts in accordance with Item 445, "Galvanizing."

Treat welds with Ultrasonic Impact Treatment as shown on the plans after galvanization and with the dead load (actual or simulated) applied. Repair damaged galvanizing in accordance with Section 445.3.D, "Repairs."

Connect the luminaire arm to the pole with simplex fittings. Ensure the fittings have no defects affecting strength or appearance.

Ensure that the design wind speed is identified and permanently visible on the pole base plate and mast arm mounting plate.

Deliver each traffic signal pole assembly with fittings and hardware either installed or packaged with its associated components. Ship all components with a weatherproof tag identifying the manufacturer, contract number, date, and destination of shipment.

- C. Installation.** Locate traffic signal poles as shown on the plans unless otherwise directed to secure a more desirable location or to avoid conflict with utilities. Stake the traffic signal pole locations for verification by the Engineer.

Construct foundations in accordance with Item 416, "Drilled Shaft Foundations." Orient anchor bolts as shown on the plans.

Use established industry and utility safety practices when working near underground or overhead utilities. Consult with the appropriate utility company before beginning such work.

Erect structures after foundation concrete has attained its design strength as required in the plans and Item 421, "Hydraulic Cement Concrete." Coat anchor bolt threads and tighten anchor bolts in accordance with Item 449, "Anchor Bolts."

After the traffic signal pole assembly is plumb and all nuts are tight, tack-weld each anchor bolt nut in 2 places to its washer. Tack-weld each washer to the base plate in 2 places. Do not weld components to

686.4 to 686.5

the bolt. Tack-weld in accordance with Item 441, “Steel Structures.” After tack-welding, repair galvanizing damage on bolts, nuts, and washers in accordance with Section 445.3.D, “Repairs.”

Do not grout between the base plate and the foundation.

- D. Relocation.** Disconnect and isolate traffic signal cables before removing the pole. Remove existing traffic signal poles as directed. Ensure that the poles or attached components suffer no undue stress or damage. Signs, signal heads, mounting brackets, luminaires, etc., may be left on the poles. Repair or replace damaged components as directed.

Unless otherwise shown on the plans, remove abandoned concrete foundations to a point 2 ft. below final grade. Backfill the hole with materials equal in composition and density to the surrounding area. Replace surfacing material with similar material to an equivalent condition.

Move existing poles to locations shown on the plans or as directed. Install existing poles on new foundations in accordance with Section 686.3.C, “Installation.”

Accept ownership of unsalvageable materials and dispose of in accordance with federal, state, and local regulations.

686.4. Measurement. This Item will be measured by each traffic signal pole assembly installed or relocated.

686.5. Payment. The work performed and materials furnished in accordance with this Item and measured as provided under “Measurement” will be paid for at the unit price bid for “Install Traffic Signal Pole Assemblies (Steel)” of the types and sizes specified or “Relocate Traffic Signal Pole Assemblies (Steel)” of the types specified.

New drilled shaft foundations will be paid for under Item 416, “Drilled Shaft Foundations.”

- A. Installation.** This price is full compensation for furnishing, fabricating, galvanizing, assembling, and erecting the pole upon a foundation; furnishing and erecting required mast arms and luminaire arms; furnishing and placing anchor bolts, nuts, washers, and templates; and equipment, materials, labor, tools, and incidentals.
- B. Relocation.** This price is full compensation for removing traffic signal poles; removing existing foundations; backfilling and surface placement; storing the components to be reused or salvaged; furnishing, fabricating, and installing required new components; placing and

securing traffic signal poles on new foundations; furnishing and placing conduit, ground rods, and wiring; disposal of unsalvageable material; loading and hauling; and equipment, material, labor, tools, and incidentals.

ITEM 687

PEDESTAL POLE ASSEMBLIES

687.1. Description. Furnish and install pedestal pole assemblies for vehicle and pedestrian signals.

687.2. Materials. Furnish new materials in accordance with the following Items and with details shown on the plans:

- Item 445, “Galvanizing”
 - Item 449, “Anchor Bolts”
 - Item 656, “Foundations for Traffic Control Devices.”
- A. Pedestal Pole Base.** Provide pedestal pole bases in accordance with DMS-11140, “Pedestal Pole Base.” Provide pedestal pole bases from manufacturers prequalified by the Department. The Traffic Operations Division maintains a list of prequalified pedestal pole base manufacturers.
- B. Pedestal Pole.** Provide 4-in. diameter schedule 40 steel pipe or tubing, aluminum pipe (alloy 6061-T6), or rigid metal conduit. Do not use aluminum conduit. Galvanize pedestal pole assemblies in accordance with Item 445, “Galvanizing,” unless otherwise shown on the plans.

687.3. Construction. Install foundations in accordance with Item 656, “Foundations for Traffic Control Devices.”

- A. Pedestal Pole Base.** Ground the base with connectors to the 1/2-13 NC female threaded hole. Fabricate the base for 4 L-bend anchor bolts arranged in a square pattern with a 12-3/4-in. bolt circle. Provide mild steel anchor bolts in accordance with Item 449, “Anchor Bolts,” for each base. Provide three 1/16-in.-thick and three 1/8-in.-thick U-shaped galvanizing steel shims for each base. Size shims to fit around the anchor bolts.
- B. Installation.** Install pedestal pole assemblies as shown on the plans or as directed. Pedestal pole assemblies include foundation, pole shaft, base, anchor bolts, anchor bolt nuts, anchor bolt template, shims, and miscellaneous components. Watertight breakaway electrical

687.4 to 688.2

disconnects are required for pedestal pole assemblies used in conjunction with vehicle and pedestrian heads and components.

Use established industry and utility safety practices to erect assemblies near overhead or underground utilities. Consult with the appropriate utility company prior to beginning such work.

Repair damaged galvanizing in accordance with Section 445.3.D, "Repairs."

- C. Painted Finish.** When required, paint pedestal pole assemblies in accordance with details shown on the plans.

687.4. Measurement. This Item will be measured by each pedestal pole assembly.

687.5. Payment. The work performed and materials furnished in accordance with this Item and measured as provided under "Measurement" will be paid for at the unit price bid for "Pedestal Pole Assembly." This price is full compensation for furnishing and installing the shaft; base, shims, anchor bolts, and foundation; and materials, equipment, labor, tools, and incidentals.

New signal heads will be paid for under Item 682, "Vehicle and Pedestrian Signal Heads."

ITEM 688

PEDESTRIAN DETECTORS AND VEHICLE LOOP DETECTORS

688.1. Description. Furnish and install traffic signal detectors.

688.2. Materials. Furnish and construct materials in accordance with the following:

- Item 618, "Conduit"
- Item 624, "Ground Boxes"
- Item 682, "Vehicle and Pedestrian PedestSignal Heads"
- Item 684, "Traffic Signal Cables."

Furnish all new materials.

- A. Pedestrian Detectors.** Ensure the push-button assembly is weather-tight and tamper-proof, is designed to prevent an electrical shock under any weather condition, has provisions for grounding in accordance with the NEC, and is in compliance with the Americans with Disabilities Act (ADA).

Supply a sturdy 2-piece cast-aluminum housing unit consisting of a base housing and a removable cover. Ensure the internal components provide a push button with normal open contacts, and include all electrical and mechanical parts required for operation. Supply housing or an adapter (saddle) that conforms to the pole shape, fitting flush to ensure a rigid installation. Supply adapters of the same material and construction as the housing. Provide threaded holes for 0.5-in. conduit in the housing for any necessary conduit attachment. Close unused openings with a weather-tight closure painted to match the housing. Provide a 0.75-in. hole with an insulating bushing through the back of the housing.

Meet the paint requirements of Item 682, “Vehicle and Pedestrian Signal Heads,” for the complete body of the housing.

Ensure the manufacturer’s name or trademark is located on the housing. Supply push-button switches that have single-pole, single-throw contacts and screw-type terminals and have a design life of at least 1 million operations.

Use sheet aluminum having a minimum thickness of 0.080 in. for information signs for push buttons.

- B. Vehicle Loop Detectors.** Unless otherwise shown on the plans, use stranded copper No. 14 AWG XHHW cross-linked-thermosetting-polyethylene insulated conductor rated for 600 volts AC for vehicle detector loop wire. Ensure each length of wire shows the name or trademark of the manufacturer, the insulation voltage rating, the wire gauge, and the insulation type at approximate 2-ft. intervals on the insulation surface.

When shown on the plans, use flexible vinyl or polyethylene tubing with 0.184 in. minimum I.D., 0.031 in. minimum wall thickness, 0.26 in. maximum O.D., and a smooth bore. Use tubing that does not adhere to the loop wire in any way and is capable of resisting deterioration from oils, solvents, and temperatures up to 212°F. Use tubing that is abrasion-resistant and remains flexible from -22°F to 212°F. Unless otherwise shown on the plans, use orange or red tubing.

Use sealant for the vehicle detector loops in accordance with DMS-6340, “Vehicle Loop Wire Sealant.”

688.3. Construction.

- A. Pedestrian Detectors.** Wire the push button to the nearest splicing point or terminal strip using stranded No. 12 AWG XHHW wire with

688.3 to 688.3

600-volt insulation. Do not use terminal connections or splice wire leads except in the hand holes located in the signal pole shaft, in the signal pole base, or at locations approved by the Engineer. All allowed splices must be watertight.

Attach wires to terminal posts with solderless terminals. Attach terminals to the wires with a ratchet-type compression crimping tool properly sized to the wire.

Mount a pedestrian push button sign near each push button as shown on the plans.

B. Vehicle Loop Detectors. Provide the loop location, configuration, wire color, and number of turns shown on the plans. Loops may be adjusted by the Engineer to fit field conditions.

1. **Saw Cuts.** Cut the pavement with a concrete saw to form neat lines. Do not exceed 1 in. in depth on concrete bridge slab saw cuts. Cut all other saw cuts deep enough to provide a minimum of 1 in. depth of sealant over the wire. Unless otherwise shown on the plans, cut a separate saw cut from each loop to the edge of the pavement. Ensure the cut is clean and dry when the wire and sealant are placed.
2. **Conduit.** Place conduit between the pavement and ground box as shown on the plans.
3. **Loop Wire Color.** Unless otherwise shown on the plans, use the following color code. Use white for the first loop on the right followed by black, orange, green, brown, and blue. Use the same color for all loops in the same lane. Loops installed in multi-lanes will have the same color code in the order the loops are installed. When facing the same direction that traffic flows, the color code will read from right to left for all lanes carrying traffic in that direction. If traffic moves in 2 directions, the color code will be repeated for the other direction of traffic.
4. **Loop Wire Installation.** When shown on the plans place the loop wire in a flexible vinyl or polyethylene tubing in accordance with Article 688.2, "Materials." The loop wire color requirements do not apply to wires in tubing.

Twist the wire from the loop to the ground box a minimum of 5 turns per foot. When only 1 pair of wires is in a saw cut, it need not be twisted while in the saw cut. Do not splice loop wire in the loop or in the run to the ground box.

Hold the loop wire in place every 2 ft. with strips of rubber, neoprene flexible tubing, or polyethylene foam sealant approximately 1 in. long. Leave these strips in place, and fill the slot with loop sealant.

Splice the loop lead-in cable and loop detector wires only in the ground box near the loop it is serving. Use non-corrosive solder for splices, and ensure that the splice is watertight. Ground the drain wire of the loop lead-in cable to earth ground only at the controller or detector cabinet. Ensure the resistance from the drain wire to the ground rod is less than 1 ohm.

688.4. Measurement. This Item will be measured by the foot of saw cut containing loop wire and by each pedestrian push button.

This is a plans quantity measurement Item. The quantity to be paid is the quantity shown in the proposal, unless modified by Article 9.2, "Plans Quantity Measurement." Additional measurements or calculations will be made if adjustments of quantities are required.

688.5. Payment. The work performed and materials furnished in accordance with this Item and measured as provided under "Measurement" will be paid for at the unit price bid for "Vehicle Loop Detectors" of the type specified or "Pedestrian Detectors" of the type specified. This price is full compensation for furnishing, installing, and testing the detectors; saw-cutting, excavation, backfill, sealant, and sealant placement; pavement repair associated with saw-cutting; and equipment, materials, labor, tools, and incidentals, except as follows.

The conduit and loop wire from the edge of pavement to the ground box used for the vehicle loop detectors will not be measured or paid for directly, but will be subsidiary to this Item.

New ground boxes will be paid for under Item 624, "Ground Boxes." New loop lead-in cable will be paid for under Item 684, "Traffic Signal Cables."

ITEM 690

MAINTENANCE OF TRAFFIC SIGNALS

690.1. Description. Furnish, install, modify, repair, replace, or remove components of a traffic signal.

690.2. Materials. Unless otherwise noted on the plans, the Department will only furnish traffic signal poles, mast arms, and controllers that become part

690.2 to 690.4

of the final installation. Submit a material list to the Engineer for all poles, mast arms, and controllers needed. Pick up materials at the locations and times shown on the plans. Designate in writing the persons authorized to pick up the material.

Assume responsibility for all materials furnished by the Department. Use material furnished by the Department for this Contract only. Return unused or removed material deemed salvageable by the Engineer to the Department upon completion of the work and prior to final payment at location shown on the plans or as directed. Dispose of any material deemed not salvageable by the Engineer in accordance with federal, state, and local regulations. When materials are required to be furnished by the Contractor, meet the material requirements of the pertinent Item for the material requirements.

690.3. Equipment. Required equipment includes but is not limited to an aerial device capable of reaching overhead work, trenching machine, boring machine, concrete saw, and digger-boom truck. Use only equipment, tools, and machinery in good repair and operating condition. Repair or replace any equipment that, in the opinion of the Engineer, may affect the quality of work or safety.

690.4. Work Methods. Conform to the NEC, local utility requirements, the requirements of this Item, and the pertinent requirements of the following Items:

- Item 416, “Drilled Shaft Foundations”
- Item 421, “Hydraulic Cement Concrete”
- Item 476, “Jacking, Boring or Tunneling Pipe or Box”
- Item 610, “Roadway Illumination Assemblies”
- Item 618, “Conduit”
- Item 620, “Electrical Conductors”
- Item 622, “Duct Cable”
- Item 624, “Ground Boxes”
- Item 625, “Zinc-Coated Steel Wire Strand”
- Item 627, “Treated Timber Poles”
- Item 628, “Electrical Services”
- Item 634, “Plywood Signs”
- Item 636, “Aluminum Signs”
- Item 656, “Foundations for Traffic Control Devices”
- Item 680, “Installation of Highway Traffic Signals”
- Item 682, “Vehicle and Pedestrian Signal Heads”
- Item 684, “Traffic Signal Cables”
- Item 685, “Roadside Flashing Beacon Assemblies”
- Item 686, “Traffic Signal Pole Assemblies (Steel)”

- Item 687, “Pedestrian Pole Assemblies”
- Item 688, “Pedestrian Detectors and Vehicle Loop Detectors.”

Perform the following work as directed:

- A. **Conduit.** Install, replace, remove, or modify conduits in accordance with Item 618, “Conduit”; as shown on the plans; or as directed. Use 90° “sweep” type elbow on conduits entering a ground box.
- B. **Foundations.** Install, replace, or remove foundations for traffic signal pole and ground mount controller cabinets in accordance with Item 416, “Drilled Shaft Foundations”; in accordance with Item 656, “Foundations for Traffic Control Devices”; as shown on the plans; or as directed.
- C. **Concrete.** Install concrete in accordance with Item 421, “Hydraulic Cement Concrete.”
- D. **Ground Boxes.** Install, repair, replace, remove, or modify ground boxes in accordance with Item 624, “Ground Boxes”; as shown on the plans; or as directed.
- E. **Vehicle and Pedestrian Detectors.** Install, repair, replace, remove, or modify pedestrian push buttons and vehicle loop detectors in accordance with Item 688, “Pedestrian Detectors and Vehicle Loop Detectors”; as shown on the plans; or as directed.
- F. **Electrical Service.** Install, repair, replace, remove, or modify an electrical service assembly in accordance with Item 628, “Electrical Services”; as shown on the plans; or as directed. Mount any or all of the following on an electrical service support assembly: conduit, weather head, load center, meter base, lightning protection, wiring, and associated hardware.
- G. **Signal Pole.** Install, repair, replace, remove, or modify signal poles in accordance with pertinent Items, as shown on the plans, or as directed. Comply with Item 627, “Treated Timber Poles,” for timber signal poles with guy wires and anchors and with Item 686, “Traffic Signal Pole Assemblies (Steel),” for steel poles with concrete foundations. Remove timber poles and anchors completely, to 24 in. below ground level, or as directed. Remove concrete foundations to 24 in. below ground level or as directed.

Install, repair, replace, remove, or modify pedestrian signal pole assemblies in accordance with Item 687, “Pedestrian Pole Assemblies”; as shown on the plans; or as directed. Install, repair, replace, remove, or modify roadside flashing beacons in accordance with Item 685,

690.4 to 690.4

“Roadside Flashing Beacon Assemblies”; as shown on the plans; or as directed.

- H. Down Guy.** Install, replace, remove, or modify down guy with guard or down guy with guard and anchor.
- I. Steel Wire Strand.** Install, replace, or remove steel wire strand in accordance with Item 625, “Zinc-Coated Steel Wire Strand”; as shown on the plans; or as directed. Attach span wire on timber poles using a 5/8-in. straight thimble-eye bolt. Attach span wire on metal poles using at least 2 turns of wire around the pole. Place and properly tighten the 3-bolt clamp as near as possible to the pole.
- J. Luminaire Head and Mast Arm.** Install, replace, remove, or modify luminaire heads, arms, bulbs, photocells, and hardware on timber or steel signal poles. Install material using manufacturer’s specifications. Fuse luminaires individually in the signal pole hand hole. Install a separate cable from the breaker load panel to each luminaire.
- K. Signal Head Assembly.** Install, repair, replace, remove, or modify pedestrian signal heads or vehicle signal head assemblies in accordance with Item 682, “Vehicle and Pedestrian Signal Heads”; as shown on the plans; or as directed. Mount signal heads by a span wire hanger clamp, bracket arm assembly, or mast arm bracket assembly. Signal head assemblies consist of 1 to 12 signal sections. Install signal heads as shown on the plans or as directed.

Assemble the signal heads with backplates, louvers, and brackets as needed. Mount all signal heads at the same elevation. Install signal head perpendicular to the travel lane it controls. Plumb all signal heads vertically and horizontally.
- L. Traffic Signal Controller Cabinet, Ground Mount.** Install, repair, replace, remove, or modify ground-mounted cabinet. Plumb and tighten the cabinet. Apply silicone sealant around the base of the cabinet. Coil all cabling that enters the cabinet neatly on the cabinet floor. Mark and terminate each cable as shown on the plans or as directed.
- M. Traffic Signal Controller Cabinet, Pole Mount.** Install, repair, replace, remove, or modify pole-mounted cabinet. Plumb and tighten the cabinet. Coil all cabling that enters the cabinet neatly on the cabinet floor. Mark and terminate each cable as shown on the plans or as directed.
- N. Flashing Beacon Controller Cabinet.** Install, repair, replace, remove, or modify flasher cabinet. Plumb and tighten the cabinet. Coil all

cabling that enters the cabinet neatly on the cabinet floor. Mark and terminate each cable as shown on the plans or as directed.

- O. Cables.** Install, repair, replace, remove, or modify signal, loop lead-in, electrical, communication, or illumination cables in conduits or along messenger cables in accordance with Item 620, “Electrical Conductors”; in accordance with Item 684, “Traffic Signal Cables”; as shown on the plans; or as directed.

Attach aerial cable at 1-ft. intervals using approved cable ties along a messenger span cable. Install a drip loop of at least 2 turns at each pole, signal head, and weather head.

Label each cable brought into the controller cabinet. Coil 5 ft. of cable neatly on the traffic signal controller cabinet floor for each cable.

Install solderless pressure connectors that meet the requirements of the NEC for all wires attached to terminal posts. Use a ratchet-type full-circle crimper for insulated terminals to provide a solderless pressure connector.

- P. Sealing.** Install, repair, replace, remove, or modify sealant in detector saw slots, at the open end of all conduits terminated at the roadway edge, and in ground boxes. Apply sealant as shown on the plans or as directed.
- Q. Salvage Operations.** Remove traffic signal when no replacement is required. Return unused or removed material deemed salvageable by the Engineer to the Department. Dispose of all other material.
- R. Signal-Related Signs.** Install, repair, replace, remove, or modify small post-mounted or overhead signs.
- S. Curbs, Ramps, and Sidewalks.** Install, repair, replace, remove, or modify curbs, ramps, and sidewalks. Secure permission to install traffic signal items before cutting into or removing curbs, ramps, and sidewalks. Replace all curbs, ramps, and sidewalks as shown on the plans. Install pedestrian access ramps as shown on the plans.
- T. Protection of Utilities.** Locate and protect all public lines and utility customer service lines in the work area. Notify the utility company and locate and mark, uncover, or otherwise protect all such lines in the construction area. Obtain information on the location and grade of water, sewer, gas, telephone, electric lines, and other utilities in the work area from the utility company. This information does not relieve the Contractor of responsibility for protecting utilities.

690.5 to 690.5

Reimburse the utility line owner for expenses or costs (including fines that may be levied against the utility company) that may result from unauthorized or accidental damage to any utility lines in work area.

- U. **Preservation of Sod, Shrubbery, and Trees.** Preserve all sod, shrubbery, and trees at the site during the Contract. Obtain permission to remove any sod, shrubbery, or tree branches. Preserve and restore sod and shrubbery into their original position. Replace damaged sod or shrubbery at the Contractor's expense.

690.5. Measurement. Measurement will be as follows:

- A. **Removal of Conduit.** By the foot of conduit.
- B. **Installation of Conduit by Trenching.** By the foot of the trench containing conduit, regardless of the size of conduit.
- C. **Installation of Conduit by Jacking or Boring.** By the foot of road bore made. Pits for jacking or boring are subsidiary to this Item.
- D. **Installation of Vehicle Detectors.** By the foot of saw cut containing detector wire.
- E. **Removal, Replacement, or Installation of Ground Boxes.** By each box removed, replaced, or installed, regardless of the type of box. A concrete apron around the box will be considered subsidiary to this Item.
- F. **Removal, Replacement, or Installation of Cables.** By the foot of traffic signal cables removed, replaced, or installed, except that measurement will not be made for cable inside signal heads and controllers or for cable coiled in ground boxes, in pole bases, and on span wires.
- G. **Installation of Duct Cables.** By the foot of trench containing duct cable.
- H. **Removal, Replacement, or Installation of Cables by Messenger Cable.** By the foot removed, replaced, or installed.
- I. **Removal, Replacement, or Installation of Span Cable Assembly.** By the foot of span removed, replaced, or installed. A span is defined as the distance from one pole to the next pole.
- J. **Replacement or Installation of Electrical Service.** By each electrical service replaced or installed. The removal of the existing assembly will be considered subsidiary to this Item.

- K. Removal, Replacement, or Installation of Timber Poles.** By each timber pole removed, replaced, or installed. Attachment of required hardware is subsidiary to this Item.
- L. Removal, Replacement, or Installation of Signal Head Assemblies.** By each head removed, replaced, or installed. Assembly and wiring are subsidiary to this Item.
- M. Removal, Replacement, or Installation of Signal Related Signs.** By each sign assembly removed, replaced, or installed.
- N. Removal, Replacement, or Installation of Pedestrian Push Buttons.** By each push button removed, replaced, or installed.
- O. Removal, Replacement, or Installation of Traffic Signal Pole Foundations.** By the foot, of the type of foundation removed, replaced, or installed.
- P. Installation of Foundations for Ground Mount or Pole Mount Cabinets.** By each foundation installed.
- Q. Removal, Replacement, or Installation of Controller Cabinet, Ground Mount.** By each cabinet removed, replaced, or installed.
- R. Removal, Replacement, or Installation of Controller Cabinet, Pole Mount.** By each cabinet removed, replaced, or installed.
- S. Removal, Replacement, or Installation of Flasher Cabinet.** By each cabinet removed, replaced, or installed.
- T. Installation of Foundations for Roadside Flashing Beacon Assemblies.** By each foundation installed.
- U. Removal, Replacement, or Installation of Roadside Flashing Beacon Assemblies.** By each assembly removed, replaced, or installed.
- V. Removal, Replacement, or Installation of Signal Pole Assemblies.** By each assembly, according to the type of pole assembly removed, replaced, or installed. Wiring in the pole and hardware is subsidiary to this Item.
- W. Removal, Replacement, or Installation of Curbs.** By the foot removed, replaced, or installed.
- X. Removal, Replacement, or Installation of Pedestrian Ramps.** By each ramp removed, replaced, or installed.
- Y. Removal, Replacement, or Installation of Sidewalks.** By the square foot removed, replaced, or installed.
- Z. Removal of Concrete Foundations.** By each foundation removed.

690.6 to 690.6

AA. Removal, Replacement, or Installation of Luminaire Heads. By each luminaire head removed, replaced, or installed.

BB. Removal, Replacement, or Installation of Luminaire Mast Arms. By each mast arm removed, replaced, or installed.

690.6. Payment. The work performed and the materials furnished in accordance with this Item and measured as provided under “Measurement” will be paid for at the unit prices for the various designations. This price is full compensation for furnishing all material, equipment, labor, fines, tools, and incidentals. The Department will pay for electrical energy consumed by the traffic signal.

Wiring in the pole; splices; backfill (soil or concrete); sealing of conduit ends and loop detector saw slots; installation of loop wire and PVC for encased loops; protection of utilities; and preservation of sod, shrubbery, and trees will not be measured or paid for directly but will be subsidiary to pertinent Items.

700 ITEMS — MAINTENANCE

ITEM 700

POTHOLE REPAIR

700.1. Description. Repair potholes, spalled areas, depressions, and raveled or damaged pavement edges in roadway surfaces.

700.2. Materials. Furnish materials, unless otherwise shown on the plans. Use materials that meet the requirements of the following Items, as shown on the plans:

- Item 300, “Asphalt, Oils, and Emulsions”
- Item 330, “Limestone Rock Asphalt Pavement”
- Item 334, “Hot-Mix Cold-Laid Asphalt Concrete Pavement”
- Item 340, “Dense Dense-Graded Hot-Mix Asphalt (Method)”
- DMS-9201, “Asphaltic Concrete Patching Material (Performance Guaranty)”
- DMS-9202, “Asphaltic Concrete Patching Material (Stockpile Storage)”
- DMS-9203, “Asphaltic Concrete Patching Material (Containerized)”
- DMS-9204, “Fiber Additives for Bituminous Mixtures.”

700.3. Work Methods. Work requests are made on a callout basis. Begin physical repair within 24 hr. of notification, 3 hr. if emergency mobilization is required, unless otherwise shown on the plans.

- A. Standard Repair.** Remove loose and foreign materials from the repair area. Remove water, dry, and apply tack coat to surfaces of the repair area unless otherwise directed.
- B. Saw-Cut Repair.** Square the sides of the repair area by saw-cutting or other approved methods. Remove loose and foreign material. Clean and dry the repair area. Apply tack coat to surfaces of the repair area unless otherwise directed.

Place repair material in horizontal lifts no more than 3 in. deep. Finish to grade and compact to conform to roadway surface. Compact with hand tamp, mechanical tampers, or rollers as directed or approved. Compact to achieve full consolidation.

Repair pavement edges to the line and grade of original pavement. Clean roadway surface after repair operations. Dispose of materials removed as directed or approved.

700.4 to 712.1

700.4. Measurement. Emergency mobilization will be measured by each emergency work request. Pothole repair will be measured by the square yard of surface area or by the cubic yard, ton, or pound of material used. For Contracts with callout work without emergency mobilization, the minimum quantity per callout respectively is 5 sq. yd., 1/2 cu. yd., 1/2 ton, or 150 lb., unless otherwise shown on the plans.

- A. Area.** The surface area of repairs will be measured.
- B. Volume.** Trucks will be measured and the loose volume in cubic yards will be calculated for legally transported loads. Level the load for measurement before beginning work. Level off the material remaining on the last load for measurement. Material not used at the end of the day will be deducted from the volume. Dispose of hot-mix asphalt concrete pavement remaining at the end of a day.
- C. Weight (Ton).** Trucks will be weighed on certified scales. Provide weight tickets. Material not used at the end of the day will be deducted from the weight. Dispose of hot-mix asphalt concrete pavement remaining at the end of a day. Measurement will be in accordance with Item 520, "Weighing and Measuring Equipment."
- D. Weight (Pound).** Materials furnished in a container will be measured by the pound as shown on the container.

700.5. Payment. The work performed and materials furnished in accordance with this Item and measured as provided under "Measurement" will be paid for at the unit prices bid for "Pothole Repair (Standard)" or "Pothole Repair (Saw-Cut)" and for "Emergency Mobilization," if required. The price bid for pothole repair is full compensation for furnishing materials, unless otherwise shown on the plans; application of the tack coat; removal and disposal of debris and excess material; leveling off or weighing the load for measurement; and equipment, labor, tools, and incidentals.

The price bid for emergency mobilization is full compensation for beginning physical work within 3 hr. of notification. Emergency mobilization will be paid for in addition to pothole repair.

ITEM 712

CLEANING AND SEALING JOINTS AND CRACKS

(ASPHALT CONCRETE)

712.1. Description. Clean and seal joints and cracks in asphalt concrete roadway surfaces.

712.2. Materials. Furnish materials unless otherwise shown on the plans. Furnish sealant materials as shown on the plans in accordance with Item 300, "Asphalts, Oils, and Emulsions." Furnish an approved fine aggregate.

712.3. Equipment. Furnish equipment, tools, and machinery for proper prosecution of the work.

- A. Hot Applied Sealants.** Heat in a double-jacketed heater using a heat transfer oil so that no direct flame comes in contact with the shell of the vessel containing the sealing compound. Provide a heater capable of circulating and agitating the sealant during the heating process to achieve a uniform temperature rise and to maintain the desired temperature. Provide gauges to monitor the temperature of the vessel contents and to avoid overheating the material. Provide a heater equipped with a gear-driven asphalt pump with adequate pressure to dispense the sealant.
- B. Cold Applied Sealants.** Provide equipment with adequate pressure to dispense the sealant in a continuous flow.

712.4. Work Methods. Clean and seal joints and cracks that are 1/16 in. or greater in width. When required, rout joints and cracks to the configuration shown on the plans. Clean joints and cracks with air blast cleaning or other acceptable methods to a depth of least twice the joint or crack width. Joints and cracks must be free of moisture before sealing. Dispose of materials removed as directed or approved. Apply sealing material with a pressure nozzle. Completely fill cracks and joints. Squeegee material to no more than 3 in. wide and 1/8 in. above the pavement surface. Prevent tracking with an application of fine aggregate as directed.

712.5. Measurement. This Item will be measured by the foot, gallon, pound, or lane mile. Shoulders wider than 6 ft. are considered additional lanes.

712.6. Payment. The work performed and materials furnished in accordance with this Item and measured as provided under "Measurement" will be paid for at the unit price bid for "Joint and Crack Sealing" of the sealant material specified and "Joint and Crack Routing and Sealing" of the sealant material specified. This price is full compensation for routing, cleaning, and sealing joints and cracks; furnishing and placing materials; and equipment, labor, tools, and incidentals.

720.1 to 720.4

If measurement is by the lane mile, shoulders 6 ft. or narrower will not be paid for directly but will be subsidiary to work on the adjacent travel lane.

ITEM 720

REPAIR OF SPALLING IN CONCRETE PAVEMENT

720.1. Description. Repair spalling and partial-depth failures in concrete pavement.

720.2. Materials. Furnish either rapid-set concrete or polymeric patching material unless otherwise shown on the plans.

A. Rapid-Set Concrete. Provide concrete that meets DMS-4655, "Rapid-Hardening Cementing Materials for Concrete Repair."

Use a packaged blend of hydraulic cement, sand, and gravel (maximum size 3/8 in.) which requires the addition of water and has a maximum shrinkage of 0.15% in accordance with ASTM C 928.

Do not use chlorides, magnesium or gypsum to accelerate setting time.

Before spall repair operations, demonstrate that the mixture achieves flexural strength of at least 425 psi in 5 hr., a minimum compressive strength of 5,100 psi in 7 days, and 6,300 psi in 28 days. Test in accordance with Tex-418-A and Tex-448-A.

B. Polymeric Patching Material. Provide polymeric patching material that meets DMS-6170, "Polymeric Materials for Patching Spalls in Concrete Pavement," and matches the color of the pavement.

720.3. Equipment. Furnish equipment in accordance with Item 429, "Concrete Structure Repair," or as approved.

720.4. Work Methods. Repair areas as shown on the plans or as directed. Dispose of debris off the right of way in accordance with federal, state, and local regulations.

A. Hydraulic Cement Concrete Material. Saw at least 1 1/2 in. deep around repair area before concrete removal, unless otherwise directed, providing a vertical face around the perimeter of the repair area.

Provide a uniform rough surface free of loose particles and suitable for bonding. Remove concrete to a depth of 1 1/2 in. or the depth of deteriorated concrete, whichever is greater. Use chipping hammers not heavier than the nominal 15-lb. class or hydrodemolition equipment for the removal of concrete below 1 1/2 -in. depth. Mix, place, and cure in

accordance with manufacturer's recommendations. Do not place concrete if the air temperature is below 40°F. Screed concrete to conform to roadway surface. Provide a rough broom finish.

- B. Polymeric Patching Material.** Submit for approval a statement from the manufacturer identifying the recommended equipment and installation procedures. Remove the deteriorated concrete to the dimensions shown on the plans or as directed. Dry and abrasive-blast the repair area to ensure it is free from moisture, dirt, grease, oil, or other foreign material that may reduce the bond. Remove dust from the abrasive blasting operation. Apply primer to the repair area. Reapply primer if conditions change before placing patching material. Mix, place, and cure in accordance with manufacturer's recommendations. Begin placement of material at the lower end of sloped areas. Screed polymeric patching material to conform to the roadway surface. Provide a non-skid finish with a notched trowel.

720.5. Measurement. This Item will be measured as follows:

- A. Hydraulic Cement Concrete Material.** By the cubic foot of concrete repair material placed.
- B. Polymeric Patching Material.** By the gallon of polymeric patching material placed.

720.6. Payment. The work performed and materials furnished in accordance with this Item and measured as provided under "Measurement" will be paid for at the unit price bid for "Spalling Repair" of the type (Hydraulic Cement; Polymeric, Flexible; or Polymeric, Semirigid) specified. This price is full compensation for sawing, chipping, milling, cleaning, abrasive-blasting, repairing spalled concrete pavement, disposal of materials, materials, equipment, labor, tools, and incidentals.

ITEM 730 ROADSIDE MOWING

730.1. Description. Mow roadside vegetation.

730.2. Equipment.

- A. Mowers.** Provide either rigid-frame or batwing rotary mowers equipped with sharp blades to cleanly cut vegetation and with deflection devices to prevent flying debris ejected by the mowers,

730.3 to 730.3

unless otherwise shown on the plans. Do not use rigid-frame mowers wider than 9 ft. in cutting width.

- B. Emblems.** Provide slow-moving vehicle emblem affixed to rear of mowers.
- C. Warning Lights.** Provide highly visible omni-directional amber flashing warning lights on tractors and work trucks.
- D. Trimmers.** Provide trimmers for hand trimming.

730.3. Work Methods.

A. Requirements.

- Set mower cutting height 5 to 7 in. or as directed.
- Perform mowing sequence as directed or as approved.
- Do not mow wet ground when rutting can occur, unless otherwise approved.
- Do not mow designated non-mow areas.
- Immediately remove debris ejected onto the roadway. Remove mowed grass from roadway when determined to be a hazard.
- Hand-trim around fixed objects within mowed area. Complete hand trimming on each roadway within 24 hr. of mowing. Do not damage trees or shrubs.
- Restore appurtenances damaged by mowing operations, in accordance with Article 7.12, "Contractor's Responsibility for Work."
- Do not mow stands of wildflowers before seeds have matured, unless otherwise directed.

B. Mowing Types.

1. Strip Mowing.

- Mow a strip of vegetation along edge of pavement or unpaved shoulder, in accordance with details shown on the plans.
- Mow to provide sight distance at horizontal curves, intersections, driveways, and ramps.
- Mow to right of way line where specified.
- Mow around appurtenances within the strip width.
- Mow entire right of way under bridges and in drainage channels.
- Provide a 6-to-1 transition between the strip width and other areas requiring a different width.
- Mow the entire width of medians and outer separations (areas between main lanes, ramps, and frontage roads), except for non-mow areas.

2. **Full-Width Mowing.** Mow vegetation in the entire right of way, except for non-mow areas.
3. **Spot Mowing.** Work requests are made on a callout basis. Begin mowing designated areas within 48 hr. of notification, unless otherwise shown on the plans.

730.4. Measurement. This Item will be measured by the acre.

- A. **Strip and Full-Width Mowing.** “Strip Mowing” and “Full-Width Mowing” are plans quantity measurement items. The quantity to be paid is the quantity shown on plans, unless modified by Article 9.8, “Plans Quantity Measurement.” Additional measurements or calculations will be made if adjustments of quantities are required.
- B. **Spot Mowing.** “Spot Mowing” will be measured by the acre mowed. The minimum quantity per callout is 3 acres, unless otherwise shown on the plans.

730.5. Payment. The work performed and materials furnished in accordance with this Item and measured as provided under “Measurement” will be paid for at the unit price bid for “Strip Mowing,” “Full-Width Mowing,” or “Spot Mowing.” This price is full compensation for furnishing and operating equipment and for materials, tools, and incidentals.

ITEM 734

LITTER REMOVAL

734.1. Description. Remove and dispose of litter. Litter includes matter not part of the highway facility, such as trash, garbage, scrap metals, paper, wood, plastic, glass products, animal remains, rubber products, tires, auto parts, furniture, mattresses, household appliances, and large bulky items.

734.2. Materials. Furnish bags and containers.

734.3. Equipment. Provide equipment and tools. Provide highly visible omni-directional amber flashing warning lights on work vehicles. Provide equipment that prevents the accumulated debris from being strewn along the roadway during transport.

734.4. Work Methods. Remove bagged litter on the same day it is collected. Do not remove dead animals larger than 150 lb. or hazardous materials; instead notify the Department for removal. Dispose of litter off

734.4 to 735.3

the right of way in accordance with federal, state, and local regulations. Perform litter removal and disposal according to the following types.

- A. **Litter.** Remove and dispose of litter from the right of way, including shoulders but excluding the traveled lanes and shoulders next to barriers, to the limits shown on the plans.
- B. **Spot Litter.** Work requests are made on a callout basis. Begin removing litter within 3 hr. of notification, unless otherwise shown on the plans.

734.5. Measurement. This Item will be measured as follows.

- A. **Litter.** By the cycle or acre.
- B. **Spot Litter.** By the acre. The minimum quantity per callout is 3 acres, unless otherwise shown on the plans.

734.6. Payment. The work performed and materials furnished in accordance with this Item and measured as provided under “Measurement” will be paid for at the unit prices bid for “Litter Removal” or “Litter Removal (Spot).” This price is full compensation for collecting, hauling, and disposing of litter and for equipment, labor, materials, tools, and incidentals.

ITEM 735 DEBRIS REMOVAL

735.1. Description. Remove and dispose of debris discarded or deposited on or adjacent to the pavement. Debris includes objects not part of the highway facility, such as dead animals, tires, tire fragments, wood, furniture, mattresses, household appliances, and scrap metal.

735.2. Equipment. Provide highly visible omnidirectional flashing warning lights on work vehicles. Provide equipment that prevents the accumulated debris from being strewn along the roadway during transport.

735.3. Work Methods. Remove debris at locations shown on the plans. Dispose of debris off the right of way in accordance with applicable federal, state, and local regulations.

- A. **Center Medians and Mainlanes.** Remove and dispose of debris from the main travel lanes, paved medians, paved shoulders, and an additional 5 ft. adjacent to the pavement, unless otherwise shown on the plans.

- B. Frontage Roads.** Remove and dispose of debris from frontage roads, shoulders, U-turn lanes, and intersecting streets to the right-of-way line, including turn lanes, underpasses and overpasses, and an additional 5 ft. adjacent to the pavement, unless otherwise shown on the plans.
- C. Entrance and Exit Ramps.** Remove and dispose of debris from ramps, shoulders, and an additional 5 ft. adjacent to the pavement, unless otherwise shown on the plans.
- D. Spot Debris Removal.** Work requests are made on a callout basis. Remove and dispose of debris as directed. Begin removing debris within 3 hr. of notification, unless otherwise shown on the plans.

735.4. Measurement. This Item will be measured as follows:

- A. Center Medians and Mainlanes, Frontage Roads, and Entrance and Exit Ramps.** By the cycle or right-of-way centerline mile. A right-of-way centerline mile is defined as the distance from beginning reference marker location to ending reference marker location, regardless of the number of roadbeds.
- B. Spot Debris Removal.** By the roadbed mile. The minimum quantity per callout is 1 roadbed mile, unless otherwise shown on the plans.

735.5. Payment. The work performed and materials furnished in accordance with this Item and measured as provided under “Measurement” will be paid for at the unit prices bid for “Debris Removal” of the specified types. This price is full compensation for collecting, hauling and disposing of debris and for equipment labor, materials, tools, and incidentals. Traffic control will not be paid for directly but will be subsidiary to this Item, unless otherwise shown on the plans.

Debris removal required for work orders issued under Item 734, “Litter Pickup,” or Item 738, “Cleaning and Sweeping Highways,” will be subsidiary to that Item unless otherwise shown on the plans.

ITEM 738

CLEANING AND SWEEPING HIGHWAYS

738.1. Description. Clean and sweep highway facilities.

738.2. Equipment. Furnish equipment and tools capable of dislodging crusted debris from road surfaces and removing and collecting materials from roadway. Provide highly visible omni-directional flashing warning lights on work vehicles. Equipment must have a water tank with adequate

738.2 to 738.4

spray assemblies for dust control and a dirt hopper with sufficient capacity to allow progress with minimum interference to traffic. Provide other types of cleaning and sweeping equipment, including hand tools, when required.

738.3. Work Methods. Completely remove debris from pavement surfaces and other areas designated on the plans, such as all sides of raised pavement markers, barrier drain slots, slotted drains, inlet openings, attenuators, and guardrails. Collect the debris and dispose of it off the right of way in accordance with federal, state, and local regulations. Do not sweep around any debris. Do not blow debris onto traffic lanes. Debris is defined as dirt and other matter not part of the highway facility. The types of cleaning and sweeping are as follows.

- A. Center Median Cleaning and Sweeping.** Clean and sweep the paved center medians or left paved shoulders and left paved gutters.
- B. Outside Main Lane Cleaning and Sweeping.** Clean and sweep the outside lanes or right paved shoulders and paved gutters. Clean and sweep intersecting streets to the right-of-way line.
- C. Frontage Road Cleaning and Sweeping.** Clean and sweep the right and left paved shoulders and paved gutters on all frontage roads. Clean and sweep U-turn lanes and intersecting streets to the right-of-way line, including turn lanes, underpasses, and overpasses.
- D. Entrance and Exit Ramp Cleaning and Sweeping.** Clean and sweep right and left paved shoulders and paved gutters of ramps.
- E. Aggregate Removal.** Clean and remove aggregate from designated areas following adverse weather conditions.
- F. Spot Sweeping.** Work requests are made on a callout basis. Clean and sweep roadways in designated areas. Begin sweeping within 3 hr. of notification, unless otherwise shown on the plans.
- G. Handwork.** Clean and sweep areas as shown on the plans or as directed.

738.4. Measurement. Right-of-way centerline mile is defined as the distance measured from the beginning point to the ending point shown on the plans and is measured once regardless of the number of lanes or roadbeds.

Ramp centerline mile is defined as the distance measured along each ramp regardless of the number of lanes. A roadbed mile is defined as the distance along each roadbed regardless of the number of lanes.

Types of cleaning and sweeping will be measured as follows.

- A. **Center Median.** By the cycle or right-of-way centerline mile.
- B. **Outside Mainlane.** By the cycle or right-of-way centerline mile.
- C. **Frontage Road.** By the cycle or right-of-way centerline mile.
- D. **Entrance and Exit Ramp.** By the cycle or ramp centerline mile.
- E. **Aggregate Removal.** By the roadbed mile.
- F. **Spot.** By the roadbed mile. The minimum quantity per callout is 1 roadbed mile, unless otherwise shown on the plans.
- G. **Handwork.** By the square yard.

738.5. Payment. The work performed and materials furnished in accordance with this Item and measured as provided under “Measurement” will be paid for at the unit price bid for “Cleaning and Sweeping” of the specified type. This price is full compensation for cleaning, sweeping, collecting, hauling, and disposing of debris and for equipment, labor, materials, tools, and incidentals.

When work requests include multiple bid Items and overlap occurs, the measurement and payment priority will be determined by the order shown in “Measurement.”

Cleaning of items such as raised pavement markers, barrier drain slots, slotted drains, inlet openings, and areas adjacent to attenuator and guardrail supports will not be paid for directly but will be subsidiary to this Item unless otherwise shown on the plans.

ITEM 740

GRAFFITI REMOVAL AND ANTI-GRAFFITI COATING

740.1. Description. Remove graffiti or apply anti-graffiti coating on concrete or steel.

740.2. Materials. Furnish paint meeting the requirements of Item 446, “Cleaning and Painting Steel,” for steel structures. Furnish Class B coating meeting the requirements of Item 427, “Surface Finishes for Concrete,” for concrete structures unless otherwise shown on the plans. Furnish anti-graffiti coating of the type specified, in accordance with DMS-8111, “Anti-Graffiti Coatings.” Furnish graffiti removal chemicals as approved.

740.3. Work Methods. Graffiti is defined as inscriptions or drawings placed on fixtures, structures, riprap, etc. Do not remove graffiti from signs unless otherwise specified.

740.3 to 740.3

Work requests are made on a callout basis. Begin graffiti removal within 24 hr. of notification, unless otherwise shown on the plans.

Shape treated area to a rectangular configuration. Control dust or water to prevent a hazard to traffic. Ensure that treated areas exhibit a uniform clean appearance upon completion. When using a chemical cleaning method, follow the manufacturer's recommendations and use a low-pressure (less than 1,000 psi) water wash.

A. Graffiti Removal. Remove graffiti by any of the following methods as approved:

1. Concrete Structures.

a. Surfaces Without Anti-Graffiti Coating.

- (1) **Blast Cleaning.** Use abrasive blasting, water blasting, or steam cleaning.
- (2) **Chemical Cleaning.** Follow the manufacturer's recommendations.
- (3) **Painting.** Prepare surface by approved methods before painting. Paint over the graffiti on concrete in accordance with Item 427, "Surface Finishes for Concrete." Match the color of the existing surface.

b. Surfaces with Anti-Graffiti Coating.

- (1) **Sacrificial Anti-Graffiti Coating.** Do not paint over existing anti-graffiti coatings.
 - (a) **Blast Cleaning.** Use abrasive blasting, water blasting, or steam cleaning.
 - (b) **Chemical Cleaning.** Follow the manufacturer's recommendations.
- (2) **Permanent Anti-Graffiti Coating.** Use chemical cleaning.

2. Metal Surfaces.

a. Painted Surfaces. Prepare surface as approved. Paint over the graffiti on metal in accordance with Item 446, "Cleaning and Painting Steel." Match the color of the existing surface.

b. Galvanized or Unpainted Surfaces. Use chemical cleaning.

B. Application of Anti-Graffiti Coating. Apply anti-graffiti coatings on concrete surfaces only. Anti-graffiti coatings require a dry surface. Apply anti-graffiti coatings when the temperature of the atmosphere,

substrate surface, and material is 50°F or above. Do not apply anti-graffiti coatings when impending weather conditions might result in injury to the fresh coating. Do not apply anti-graffiti coatings over any existing appearance coating unless otherwise shown on the plans.

Blast-clean all surfaces in accordance with Item 427, "Surface Finishes for Concrete," to remove old coatings, laitance, curing compound, dirt, grime, and other contaminants.

Apply a primer, when required by the manufacturer, in accordance with the manufacturer's recommendations. Apply anti-graffiti coatings by spray, by roller, or by brush at the application rates recommended by the manufacturer. Do not thin the anti-graffiti coating without prior approval. Replace permanent anti-graffiti coatings not meeting a methylethyl ketone rub test when tested in accordance with ASTM D 4752.

740.4. Measurement. This Item will be measured by the square foot. The minimum quantity per callout is 50 sq. ft., unless otherwise shown on the plans.

740.5. Payment. The work performed and materials furnished in accordance with this Item and measured as provided under "Measurement" will be paid for at the unit price bid for "Graffiti Removal (Blast Cleaning)," "Graffiti Removal (Painting)," "Graffiti Removal (Chemical Cleaning)," "Anti-Graffiti Coating (Sacrificial)," and "Anti-Graffiti Coating (Permanent)." This price is full compensation for cleaning, painting, equipment, labor, materials, tools, and incidentals.

ITEM 745

PICNIC AND REST AREA MAINTENANCE

745.1. Description. Perform janitorial and grounds maintenance at picnic and rest areas.

745.2. Materials. Furnish materials and supplies unless otherwise shown on the plans. Obtain approval of materials before use.

745.3. Work Methods. The number and location of picnic or rest areas, the number of attendants, work days and specified staffing hours, frequency of maintenance, and other scheduled work items will be as shown on the plans, or as directed.

745.3 to 745.3

Report any needed repairs or vandalism when discovered. Secure “Lost and Found” items and report items found daily. Do not accept tips or other gratuities.

For maintenance operations in rest areas:

- Use separate crews for grounds and for janitorial maintenance unless otherwise approved.
- Store equipment and supplies in the designated storage area. Keep materials and tools in storage area when not in use.
- Keep the area clean and orderly. Lock the storage area when not in use.
- Do not allow employee’s relatives or visitors to stay in the rest area during working hours.
- Provide at least one English-speaking employee per rest area unless otherwise approved.
- Unless otherwise approved, wear uniforms consisting of khaki or navy blue pants, khaki shirt with “Rest Area Contractor” emblem embroidered on the chest area above the pocket, and a khaki colored baseball cap with “Rest Area Contractor” emblem embroidered on the front.
- Report malfunctions immediately. The Department is responsible for facility repairs, except for damage caused by Contractor operations.

A. Janitorial Maintenance.

1. **Rest Areas Only.** Perform the following services twice daily or more often as needed, or as shown on the plans:
 - Staff the facility for the specified hours.
 - Clean floors with solution of water and cleaner. Thoroughly remove cleaning solution. Furnish and display “Caution Wet Floor” signs until floor is dry.
 - Clean doors, woodwork, handrails, partitions, and walls adjacent to restroom fixtures. Thoroughly remove cleaning solution. Clean other walls and ceilings as directed. Do not use abrasive cleaning powders to clean walls and ceilings.
 - Clean surfaces of lavatories, including levers, spouts, and drains. Thoroughly remove cleaning solutions and wipe dry.
 - Scrub inner surfaces of urinals and toilets. Clean seat, rim, and other surfaces of fixtures. Wipe dry exterior surfaces and rims. Disinfect and deodorize toilet fixtures.
 - Clean glass mirrors with glass cleaner and wipe dry. Clean stainless steel mirrors with a mild liquid soap and wipe dry with soft cloth.
 - Empty trash receptacles.
 - Supply toilet tissue and hand soap.

- Close one restroom at a time for a maximum of 20 min. during each cleaning operation. Do not close restrooms or stalls unless they are being cleaned or are out of order.
- Remove graffiti immediately in accordance with Item 740, “Graffiti Removal and Anti-Graffiti Coating,” except for measurement and payment. If graffiti is painted over, display “Caution Wet Paint” signs.
- Keep drinking fountains clean. Turn off and drain water to drinking fountains if freezing temperatures are forecast. Clean inside and outside of display cases. Clean acrylic material with soft cloth and warm soapy water only.

2. Picnic and Rest Areas. Perform the following work daily, or as needed, for rest areas, and on Mondays, Wednesdays, and Fridays for picnic areas unless otherwise shown on the plans:

- Clean tables, benches, concrete pads, arbors, barbecue pits, fire boxes, and other outdoor appurtenances.
- Clean soiled or stained items with an approved cleaner or disinfectant. Rinse thoroughly with clean water. Do not apply disinfectant to tables or benches unless surfaces can be rinsed immediately. Do not use brushes or cloths used to clean restrooms to clean tables or benches.
- Remove graffiti immediately in accordance with Item 740, “Graffiti Removal and Anti-Graffiti Coating,” except for measurement and payment. If graffiti is painted over, display “Caution Wet Paint” signs.
- Remove spider webs, wasp nests, etc.
- Clean slabs, walks, and driveways.
- Keep sidewalks and grounds free of litter, including, but not limited to, trash, garbage, scrap metals, paper, wood, plastic, glass products, bottle caps, ring-pull tabs, cigarette butts, chewing gum, feces, and animal remains.
- Empty trash receptacles and replace liners. Clean trash receptacles periodically as directed. Approval is required for on-site temporary storage of collected trash. Dispose of collected trash off the right of way in accordance with federal, state, and local regulations.

B. Grounds Maintenance. Perform grounds maintenance at the frequency shown on the plans or as directed.

- 1. Mowing, Edging, and Trimming.** Pick up litter before mowing. Mow areas shown on the plans as directed. Set mower cutting height at 2 to 3 in. or as directed. When required, use push-type

745.4 to 745.5

lawn mowers or hand-held trimmers around trees, arbor units, and other appurtenances. Use tractor-driven mowers in other areas, if approved. Do not damage trees or other vegetation. Replace vegetation damaged by improper operations. Edge sidewalks, arbor units, curbs, and concrete pavement. Trim around buildings, trees, shrubs, light poles, trash receptacles, sign posts, guard posts, delineator posts, culvert headwalls, ground lights, plant beds, and other appurtenances. Remove all dirt and trimmed vegetation from curbs, walks, slabs, and parking areas. Remove weeds, grass, and other undesirable growth from plant beds and shrubs. Remove and dispose of clipping and cutting windrows and piles as directed.

2. **Watering.** Water grass, trees, and shrubs during the early morning hours at the frequency shown on the plans or as directed.
3. **Tree Pruning and Leaf Removal.** Prune dead and undesirable growth from trees and shrubs, as needed or directed. Remove and dispose of tree clippings, limbs, leaves, and pine needles as shown on the plans or as directed.
4. **Fertilizing.** Fertilize as shown on the plans.

745.4. Measurement. This Item will be measured as follows:

A. Janitorial Maintenance.

1. **Rest Areas.** By the month.
2. **Picnic Areas.** By the month or by the cycle.

B. Grounds Maintenance.

1. **Mowing and Trimming.** By the cycle or acre.
2. **Tree Pruning and Leaf Removal.** By the cycle.

745.5. Payment. The work performed and materials furnished in accordance with this Item and measured as provided under “Measurement” will be paid for at the unit prices bid for “Janitorial Maintenance (Rest Areas)” for the number of hours per day specified, “Janitorial Maintenance (Picnic Areas),” “Grounds Maintenance (Mowing and Trimming),” and “Grounds Maintenance (Tree Pruning and Leaf Removal).” A site number or numbers will be specified corresponding to the detail location description in the plans when multiple sites are bid separately. This price is full compensation for furnishing and operating equipment; for removal and disposal of prunings, limbs, clippings, leaves, and trash; and for labor, materials, tools, and incidentals.

Watering and fertilizing will not be paid for directly and will be subsidiary to the grounds maintenance mowing work.

Graffiti removal and anti-graffiti coating will not be paid for directly, but will be subsidiary to the janitorial maintenance Item.

If payment is by the month, for any day when janitorial maintenance services are not satisfactorily completed, one day's pay will be deducted from the Contractor's monthly payment. One day's pay will be determined by dividing the monthly bid price by 30 days.

ITEM 751

LANDSCAPE MAINTENANCE

751.1. Description. Perform landscape maintenance, litter pickup, mowing and edging, and irrigation repair of landscaped areas.

751.2. Materials. Furnish materials in accordance with Section 193.2, "Materials," unless otherwise shown on the plans.

751.3. Work Methods. Perform landscape maintenance as follows in designated areas at the frequency shown on the plans or as directed. Dispose of any debris off the right of way in accordance with federal, state, and local regulations.

- A. Fertilizer Application.** Apply fertilizer at the specified locations, at the analysis, times, and rate of application shown on the plans.
- B. Herbicide Application.** Comply with license requirements in Section 193.3.A, "Plant Maintenance." Control undesirable vegetation in riprap areas, plant beds, tree areas, and other locations by application of herbicide using manufacturers' recommendations, as directed. Remove dead plant debris.
- C. Irrigation System Operation and Repair.** Perform irrigation system work under the supervision of a person possessing an irrigator's license issued by the TCEQ, and provide documentation of this license. Repair deficiencies as shown on plans. Perform backflow preventer testing as necessary or as directed. Ensure that all zones are functioning properly and providing adequate moisture to maintain healthy plants using an approved watering schedule. When shown on plans, winterize the system to prevent freeze damage. Repair system using replacement parts of the same type and manufacturer as originally installed or approved equal. Provide plant irrigation by an approved alternate

751.4 to 751.4

method at no cost to the Department if the system fails due to the Contractor's actions or neglect.

- D. Leaf Removal.** Remove and dispose of tree clippings, limbs, leaves, and pine needles as shown on the plans or as directed
- E. Litter Pickup.** Pick up litter in accordance with Item 734, "Litter Removal."
- F. Mowing, Trimming, and Edging.** Mow and trim in accordance with Section 745.3.B, "Grounds Maintenance," and Item 730, "Roadside Mowing," as approved.
- G. Mulching and Reshaping of Plant Beds.** Reshape plant basins and beds. Apply and maintain mulch to a minimum depth of 2 in., unless otherwise shown on the plans. Areas and species to be mulched will be shown on the plans.
- H. Plant Bed Maintenance.** Physically remove weeds and undesirable grasses, including their root systems, from within plant beds. Trim ground covers and perform additional maintenance to plants within plant beds as required on the plans.
- I. Pruning.** Prune and trim shrubs, bushes, and trees in accordance with ANSI A300.
- J. Vegetative Watering.** Water areas not containing irrigation systems, as shown on the plans. Provide adequate moisture to maintain healthy plants. Haul water to locations where there is no municipal supply or well.

751.4. Measurement. This Item will be measured as follows:

- A. Fertilizer Application.** By the cycle.
- B. Herbicide Application.** By the cycle.
- C. Irrigation System Operation and Repair.** By the month.
- D. Leaf Removal.** By the cycle.
- E. Litter Pickup.** By the acre or by the cycle.
- F. Mowing, Trimming, and Edging.** By the acre or by the cycle.
- G. Mulching and Reshaping of Plant Beds.** By the cycle.
- H. Plant Bed Maintenance.** By the cycle.
- I. Pruning.** By the cycle.
- J. Vegetative Watering.** By the thousand gallons of water hauled or by the month.

751.5. Payment. The work performed and materials furnished in accordance with this Item and measured as provided under “Measurement” will be paid for at the unit prices bid for “Fertilizer Application,” “Herbicide Application,” “Irrigation System Operation and Repair,” “Leaf Removal,” “Litter Pickup,” “Mowing, Trimming, and Edging,” “Mulching and Reshaping of Plant Beds,” “Plant Bed Maintenance,” “Pruning,” and “Vegetative Watering” at locations specified.

This price is full compensation for equipment, labor, materials, tools, and incidentals.

Disposal of debris, leaves, and dead plants and trees will not be paid for directly, but will be subsidiary to pertinent Items.

ITEM 752

TREE AND BRUSH REMOVAL

752.1. Description. Remove and dispose of trees, brush, shrubs, and vines. Trim trees and shrubs.

752.2. Materials. Furnish commercially available pruning paint.

752.3. Equipment. Provide equipment necessary to complete the work.

752.4. Work Methods. Perform tree and brush removal and trimming from right of way line to right of way line or other widths and locations shown on the plans. Do not damage trees, shrubs, and other landscape features that are to remain. Unless otherwise approved, dispose of debris within 48 hr. of cutting, off the right of way, in accordance with federal, state, and local regulations. When approved, chip debris and spread in a thin layer on the right of way.

- A. Tree Removal.** Remove trees of various diameters as shown on the plans or as directed. Remove tree stumps to at least 12 in. below the surrounding terrain unless otherwise shown on the plans, or as directed. Backfill holes with acceptable material and compact flush with surrounding area.
- B. Tree Trimming.** Remove dead tree limbs. Remove tree limbs to the limits shown on the plans. Make cuts as close as possible to the trunk or parent limb without cutting into the branch collar or leaving a protruding stub. Remove suckers to the height of the lowest main branch.

When removing limbs 2 in. in diameter or larger:

752.5 to 752.6

- Undercut 1/3 way through the limb 8 to 12 in. from the main stem.
- Remove limb 4 to 6 in. outside the first cut.
- Remove stub with an even flush cut so that a trace (collar) protrudes approximately 1/2 in.
- Do not allow limb to fall free if it can damage other limbs or items.
- Treat exposed cuts on oak trees with pruning paint within 15 min. of the cut.

When trimming oak trees and when shown on the plans, disinfect tools with 70% methyl alcohol, chlorine solution, or other approved disinfectant before moving from one tree to another.

- C. Brush Removal.** Remove brush including but not limited to bushes, small trees, and vines growing within the right of way by cutting parallel to and within 1 in. of the ground and to the limits shown on the plans. Remove brush from under bridges, around culverts, and in channels to the limits shown on the plans.
- D. Channel Work.** Trim trees and remove brush to the limits shown on the plans, including areas under bridges.

752.5. Measurement. This Item will be measured as follows:

- A. Tree Removal.** By each tree of the diameter specified. The diameter will be measured 3 ft. above the ground. Trees less than 4 in. in diameter are considered brush. Trees with multiple trunks at the point of measurement will be measured separately and paid for according to the specified diameter.
- B. Tree Trimming and Brush Removal.** By the centerline mile. “Centerline mile” is defined as the continuous measurement along the center of the right of way.
- C. Tree Trimming and Brush Removal for Channels.** By the acre.

752.6. Payment. The work performed in accordance with this Item and measured as provided under “Measurement” will be paid for at the unit price bid for “Tree Removal” of the diameter specified, “Tree Trimming,” “Brush Removal,” and “Tree Trimming and Brush Removal.” This price is full compensation for removal, trimming, disposal, equipment, traffic control, labor, and incidentals.

When not shown on the plans as a separate pay item, payment for tree trimming and brush removal in channels will be included in payment by the centerline mile. When shown on the plans as a separate pay item, tree trimming and brush removal in channels will be paid for at the unit price bid for “Tree Trimming and Brush Removal (Channels).”

The limits shown on the plans are the limits for pay purposes unless otherwise modified in accordance with Article 4.2, "Changes in the Work."

ITEM 760

CLEANING AND RESHAPING DITCHES

760.1. Description. Clean and reshape ditches.

760.2. Work Methods. Excavate and remove excess material from ditches and from around fixtures within the limits of the excavation. Reshape ditches in conformance with the lines, grades, and typical cross-sections shown on the plans or as directed. Dispose of excess material in accordance with applicable federal, state, and local regulations, or place on right of way, as directed. Maintain ditch drainage during cleaning and reshaping work.

760.3. Measurement. Measurement will be as follows:

- A. Foot.** By the foot, measured along the centerline of the ditch.
- B. Cubic Yard in Place.** By the cubic yard in its original position computed by the method of average end areas.
- C. Cubic Yard in Vehicle.** By the cubic yard in vehicles measured at the point of excavation.

760.4. Payment. The work performed in accordance with this Item and measured as provided under "Measurement" will be paid for at the unit price bid for "Ditch Cleaning and Reshaping (Foot)," "Ditch Cleaning and Reshaping (Cubic Yard in Place)," or "Ditch Cleaning and Reshaping (Cubic Yard in Vehicle)." This price is full compensation for excavation, disposal of removed materials, reshaping, equipment, labor, tools, and incidentals.

ITEM 764

PUMP STATION AND DRAINAGE SYSTEM CLEANING

764.1. Description. Perform hydraulic cleaning and vacuum removal and disposal of debris in drain inlets, pump station wells, basket and inlet pipes, downspouts, sumps, storm sewers, and slotted drains. Debris is defined as dirt and other material not part of the drainage system.

764.2 to 764.5

764.2. Materials. Furnish materials unless otherwise shown on the plans. Furnish water that is free of industrial wastes and other objectionable material.

764.3. Equipment. Provide a self-contained, single-unit vehicle with a high-pressure water pump capable of pumping at least 60 gpm at 2,000 psi with at least 500 ft. of hose and a water storage tank of at least 1,300 gal. capacity. For pump station well and basket and inlet pipe cleaning, or if required on the plans, also provide a debris storage bin of at least 14 cu. yd. capacity and an air conveying vacuum system capable of cleaning pump station wells up to 55 ft. deep through 8 in. diameter tubing.

764.4. Work Methods. Remove and dispose of debris and wash water off the right of way in accordance with federal, state, and local regulations.

Perform hydraulic cleaning and vacuum removal as follows:

- A. Drain Inlet.** Clean the drain inlet including the top. Drain inlet cleaning includes cleaning curb inlets, grate inlets, catch basins, or manholes.
- B. Pump Station Well.** Clean the pump well floor, excluding the basket and inlet pipes.
- C. Basket and Inlet Pipe.** Clean the basket and inlet pipes at the pump station well. Unless otherwise shown on the plans, clean inlet pipes for a minimum distance of 10 ft. from inlet pipe entry into the well.
- D. Downspout.** Clean downspouts from the drain inlet on the bridge deck to the junction box, manhole, storm sewer trunk system, or outfall.
- E. Sump.** Clean the sump box.
- F. Storm Sewer.** Clean storm sewer pipe or box culvert, regardless of size or shape, for the distance required.
- G. Slotted Drain.** Clean the slotted drain, including the drainpipe below the slot. Clean the drainpipe from the downstream end of the slotted drain to the pipe outfall or to the next slotted drain in accordance with Section 764.4.F, "Storm Sewer."

764.5. Measurement. This Item will be measured by the each or foot as follows:

- A. Drain Inlet.** By each drain inlet cleaned.
- B. Pump Station Well.** By each pump station well cleaned.
- C. Basket and Inlet Pipe.** By each basket and inlet pipe cleaned.

- D. Downspout.** By each downspout cleaned.
- E. Sump.** By each sump cleaned.
- F. Storm Sewer.** By the foot of storm sewer pipe or box culvert cleaned, as measured by the hose extended into the pipe or culvert.
- G. Slotted Drain.** By the foot of drain measured along the slot. Cleaning of the drainpipe from the downstream end of the slotted drain to the pipe outfall or to the next slotted drain will be measured by the foot of hose extended into the drainpipe.

764.6. Payment. The work performed and materials furnished in accordance with this Item and measured as provided under “Measurement” will be paid for at the unit price bid for “Drain Inlet Cleaning,” “Pump Station Well Cleaning,” “Basket and Inlet Pipe Cleaning,” “Downspout Cleaning,” “Sump Cleaning,” “Storm Sewer Cleaning” of the type and size specified, and “Slotted Drain Cleaning.” This price is full compensation for cleaning, removing and disposing of debris and wash water, equipment, labor, materials, tools, and incidentals.

ITEM 770

GUARD FENCE REPAIR

770.1. Description. Repair guard fence elements, posts, terminal anchor sections, single guard fence terminals, and other appurtenances.

770.2. Materials. Furnish the following materials, unless otherwise shown on the plans:

- rail elements, posts, blockouts, fittings, and anchor concrete meeting Item 540, “Metal Beam Guard Fence”;
- single Guardrail Terminal, in accordance with Item 544, “Guard Rail End Treatments”;
- steel posts with base plates or terminal anchor posts to match original design, meeting ASTM A 36 or better;
- paint as required;
- concrete for structural repair, in accordance with Item 429, “Concrete Structure Repair”;
- grout meeting the requirements of Item 421, “Hydraulic Cement Concrete”; and
- backfill material as approved.

770.3 to 770.3

770.3. Work Methods. Replace guard fence, including thrie beam, curb, and transitions, in accordance with Item 540, "Metal Beam Guard Fence," and as shown on the plans or as directed. Work requests are made on a callout basis. Begin physical work within 72 hr. of notification, unless otherwise shown on the plans. Replace end treatments in accordance with Item 544, "Guardrail End Treatments," and as shown on the plans or as directed. Weld in accordance with Item 448, "Structural Field Welding." Repair concrete in accordance with Item 429, "Concrete Structure Repair." Remove guard fence in accordance with Item 542, "Removing Metal Beam Guard Fence." Replace rail and posts removed during the same workday, unless otherwise approved.

- Protect unattached rail elements left overnight, as approved.
 - Cover or fill postholes at the end of each day.
 - Place rail to a smooth line and grade, with posts plumb to the correct height, in accordance with the plans.
 - Remove salvageable rail elements in original lengths. Remove fittings from posts and rail elements. Deliver salvageable materials to a designated stockpile site and neatly stack as directed. Reuse salvageable materials in the repair as approved.
 - Dispose of debris and damaged components in accordance with all federal, state, and local regulations.
- A. Repair of Rail Element.** Remove and replace rail elements as directed. Bolt rail elements end to end and lap in the direction of traffic in the lane adjacent to the guard fence. Provide prefabricated curved rail when needed. Field-drill, punch, or use other approved methods to create holes for special details. Tighten nuts. Replace bridge end connection when required, in accordance with Item 540, "Metal Beam Guard Fence."
- B. Removal and Replacement of Timber or Steel Post.** Replace posts as directed. Dispose of any concrete removed. Drill new post holes as needed. Clean postholes free of loose dirt and debris, and thoroughly compact bottom of hole to the correct elevation for placement of post. Place post to the correct alignment, elevation, and plumb. Backfill with select material by thoroughly tamping in 4-in. layers. Concrete foundations will not be replaced unless directed. When replacing posts in riprap, use grout to fill space between riprap and posts.
- C. Realignment of Posts.** Realign existing posts to a smooth line and grade.

- D. Repair of Terminal Anchor Post.** Repair the steel anchor post by straightening or welding to the existing post above the concrete foundation.
- E. Replacing Terminal Anchor Posts.** Remove and replace damaged anchor posts with foundation or install new anchor posts with foundation. Remove anchor and clean existing holes or drill new holes, as approved.
- F. Removal of Guardrail End Treatment and Replacement with Single Guardrail Terminal (SGT).** Remove damaged guard fence end treatment and replace with complete new SGT.
- G. Repair of SGT.** Remove damaged SGT components and replace with new components. Salvage and reuse components as approved.
- H. Repair of Steel Post with Base Plate.** Replace damaged steel posts with base plates. Drill anchor holes and install new bolts or weld new anchor bolts to existing bolts as directed. Field-weld in accordance with Item 448, "Structural Field Welding," or shop-weld in accordance with Item 441, "Steel Structures." Repair damaged galvanized coating in accordance with Section 445.3.D, "Repairs."

770.4. Measurement. This Item will be measured as follows:

- A. Repair of Rail Element (W-Beam, Thrie-Beam, or Thrie-Beam Transition to W-Beam).** By the foot along the face of the rail from center to center of the slotted hole at each end of the rail elements repaired, including the terminal anchor section, but excluding the first 2 rail elements of the single guardrail terminal section.
- B. Removal and Replacement of Timber or Steel Posts without Concrete Foundation.** By each post replaced.
- C. Removal and Replacement of Timber or Steel Posts with Concrete Foundation.** By each post replaced.
- D. Realignment of Posts.** By each post realigned.
- E. Repair of Terminal Anchor Posts.** By each post repaired.
- F. Replacement of Terminal Anchor Posts.** By each post replaced.
- G. Removal of Guardrail End Treatment and Replacement with SGT.** By each SGT.
- H. Replacement of SGT Impact Head.** By each head.
- I. Replacement of SGT Rail.** By the foot from center to center of posts.

770.5 to 772.2

- J. Replacement of Single Guardrail Terminal Post.** By each post replaced.
- K. Replacing Steel Blockouts with Wood Blockouts.** By each blockout replaced.
- L. Repair of Steel Post with Base Plate.** By each post repaired.

770.5. Payment. The work performed and the materials furnished in accordance with this Item and measured as provided under “Measurement” will be paid for at the unit price bid for: “Repair Rail Element (W-Beam),” “Repair Rail Element (Thrie-Beam),” “Repair Rail Element (Thrie-Beam Transition to W-Beam),” “Remove and Replace Timber or Steel Post Without Concrete Foundation,” “Remove and Replace Timber or Steel Post with Concrete Foundation,” “Realign Posts,” “Repair of Terminal Anchor Posts,” “Replace Terminal Anchor Posts,” “Remove Guardrail End Treatment and Replace with SGT,” “Replace Single Guardrail Terminal Impact Head,” “Replace Single Guardrail Terminal Rail,” “Replace Single Guardrail Terminal Post,” “Replacing Steel Blockouts with Wood Blockouts,” and “Repair Steel Post with Base Plate.”

This price is full compensation for repairing rail and for furnishing equipment, materials, labor, tools, and incidentals. Realignment of existing rail without removing will not be paid for directly but will be considered subsidiary to realigning posts. Replacement of concrete riprap around posts, removal and replacement of curbs, and bridge end connection will not be paid for directly, but will be considered subsidiary to the various bid items. Concrete repair will be paid for in accordance with pertinent Items. Payment for repair of steel posts with base plate includes work performed above the concrete foundation.

ITEM 772

POST AND CABLE FENCE

772.1. Description. Install, repair, or remove post and cable fence.

772.2. Materials. Furnish materials as follows, unless otherwise shown on the plans.

- A. Posts.** Furnish timber posts meeting DMS-7200, “Timber Posts and Blocks for Metal Beam Guard Fence.”
- B. Cable.** Furnish wire cable meeting ASTM A 475 and the following requirements:

- 3/8 in. nominal strand diameter,
 - 7-wire strand, common grade,
 - minimum breaking strength of 4,000 lb., and
 - 0.30 oz. per square foot minimum weight of zinc coating.
- C. Fittings and Anchors.** Furnish fittings and anchors galvanized in accordance with ASTM A 153.
- D. Concrete.** Furnish concrete meeting Item 421, “Hydraulic Cement Concrete,” of the class shown on the plans.
- E. Reflectors.** Furnish reflectors as shown on the plans.
- F. Backfill.** Furnish backfill material as approved.

772.3. Work Methods. Install, repair, or remove post and cable fence, including reflectors and related items as shown on the plans.

- A. Removal.** Remove concrete anchors, posts, and cable. Backfill and thoroughly compact post and anchor holes. Materials removed become the property of the Contractor, unless otherwise shown on the plans. Dispose of removed materials in accordance with federal, state, and local regulations.
- B. Installation.** Place new anchors, posts, and cable as shown on plans. Set posts on firm foundation and plumb to the required lines and grades. Thoroughly compact backfill in 4 in. layers. Space pull posts as shown on the plans. Lengthen or shorten one pull post space per continuous section if necessary to accommodate site conditions. Cover or fill open holes at the end of each workday.

Existing installations may maintain their current pull post spacing if approved. Straighten undamaged posts that are more than 1 in. out of plumb. Stretch cable to remove sag between posts. One cable splice will be allowed between posts, adjacent to the post, but not more than 2 splices in any 100 ft. of cable. Painting is not required, unless otherwise shown on the plans

772.4. Measurement. This Item will be measured as follows:

- A. Post and Cable Fence Removal.** By the foot from center to center of pull posts.
- B. Concrete Anchor Removal.** By each anchor removed.
- C. New Installation of Post and Cable Fence.** By the foot of fence from center to center of pull posts for each continuous section installed.
- D. New Concrete Anchor.** By each anchor installed.

772.5 to 774.3

- E. Removal and Replacement of Posts.** By each post removed and replaced.
- F. Removal and Replacement of Concrete Anchors.** By each anchor removed and replaced.
- G. Removal and Replacement of Cable.** By the foot of cable removed and replaced.

772.5. Payment. The work performed and the materials furnished in accordance with this Item and measured as provided under “Measurement” will be paid for at the unit price bid for “Post and Cable Fence (Removal),” “Post and Cable Fence (Remove Concrete Anchor),” “Post and Cable Fence (New Installation),” “Post and Cable Fence (New Concrete Anchor),” “Post and Cable Fence (Remove and Replace Posts),” “Post and Cable Fence (Remove and Replace Concrete Anchors),” or “Post and Cable Fence (Remove and Replace Cable).” This price is full compensation for cable splices, straightening posts, tightening cable, backfilling posts and anchor holes, installation of reflectors, materials, equipment, labor, tools, and incidentals.

ITEM 774 ATTENUATOR REPAIR

774.1. Description. Repair or replace damaged attenuators or crash cushions.

774.2. Materials. Furnish materials in accordance with details shown on the plans.

774.3. Work Methods. Repair or replace attenuators as approved. For Contracts with callout work, begin physical repair within 72 hr. of notification, unless otherwise shown on the plans. Repair damaged components, such as foundation, concrete, anchors, and pavement, as necessary to ensure the final installation functions as designed. Sweep and clean area around attenuator. Dispose of debris and damaged components in accordance with federal, state, and local regulations. Weld in accordance with Item 448, “Structural Field Welding,” as directed or approved. Salvage materials as directed.

- A. Removal and Replacement.** Remove existing attenuator and replace with a system shown on plans or as directed.

- B. Repair.** Remove and replace damaged elements of attenuators and repair to meet the installation requirements of the system shown on the plans and the specifications that pertain to that appropriate system.

774.4. Measurement.

- A. Removal and Replacement.** When replacing a complete unit, measurement will be by each unit.
- B. Repair.** Repair will be measured by the each for the component specified or by the foot.

774.5. Payment. The work performed and the materials furnished in accordance with this Item and measured as provided under “Measurement” will be paid for at the unit price bid for “Remove and Replace” or “Repair” of the type or component specified. This price is full compensation for repairing or replacing attenuators; furnishing materials; salvage and disposal; and equipment, labor, tools, and incidentals.

ITEM 776

METAL RAIL REPAIR

776.1. Description. Repair metal traffic or pedestrian rail.

776.2. Materials. Furnish materials in accordance with Item 450, “Railing,” and details shown on the plans.

776.3. Work Methods. Remove damaged steel or aluminum rail and repair to match the original or details shown on the plans. For Contracts with callout work, begin physical repair within 72 hr. of notification, unless otherwise shown on the plans. Repair damaged components, anchors, etc., as necessary to ensure the final installation functions as originally constructed. Drill anchor holes and install new bolts or weld new anchor bolts to existing bolts as directed. Weld in accordance with Item 441, “Steel Structures,” or Item 448, “Structural Field Welding.” Repair damaged galvanized coating in accordance with Section 445.3.D, “Repairs.” Paint repaired areas of painted rail to match existing color, in accordance to Item 446, “Cleaning and Painting Steel.” Repair railing removed for repair during the same workday unless otherwise approved. Deliver salvageable materials to a designated stockpile site and dispose of debris and damaged components in accordance with federal, state, and local regulations.

776.4 to 780.3

776.4. Measurement. Rail repair will be measured by the foot between centers of the first undamaged post on each side of the repair or to the end of the rail. Repairing metal post with base plate will be measured by each post repaired.

776.5. Payment. The work performed and the materials furnished in accordance with this Item and measured as provided under “Measurement” will be paid for at the unit price bid for “Repair” of the type specified and “Repair Metal Post with Base Plate” of the type specified. This price is full compensation for removing and repairing rail; salvage and disposal; and materials, tools, equipment, labor, and incidentals. Concrete repair will be paid for in accordance with Item 429, “Concrete Structure Repair.”

ITEM 780 EPOXY INJECTION

780.1. Description. Seal and bond cracks in concrete with pressure-injected epoxy.

780.2. Materials. Furnish materials meeting the following:

- A. Epoxy for Crack Injection.** Meet DMS-6100 Type IX. Mix in accordance with manufacturer’s recommendations;
- B. Epoxy for Sealing the Surface of Cracks.** Meet DMS-6100 Type V or VII (light gray in color). Mix in accordance with manufacturer’s recommendations; and
- C. Fine Aggregate.** Meet Section 421.2.E.2 “Fine Aggregate.” Gradation may be modified as approved.

Do not add solvents to epoxies or use epoxies containing solvents.

780.3. Equipment. Provide positive displacement pumps with pump interlock to ensure proper mixing of the components to within $\pm 5\%$ of the ratio recommended by the epoxy manufacturer. Provide a mixing head capable of thoroughly mixing components just before injection.

To clean cracks before injection of epoxy, provide compressed-air equipment with moisture and oil traps to prevent the deposition of moisture, oils, or other contaminants in the cracks; or provide vacuum equipment. Provide routers or drills as necessary to prepare the crack surface and install injection ports.

780.4. Work Methods. Inject cracks as shown on plans or as directed. Do not inject epoxy when the concrete surface temperature or ambient temperature is 50°F or below, unless otherwise approved.

- A. Crack and Surface Preparation.** Clean the interior of cracks using either compressed air or vacuum systems to remove all loose materials entrapped in the cracks. If the surface of the concrete at the edge of the crack has deteriorated, V-groove the cracks by routing as directed. Provide a clean surface free of dust, laitance, oil, or grease around the cracks to be injected.
- B. Injection Port Installation.** Use bonded flush-fitting or vacuum-drilled and inserted ports for injection ports. Place a port at the lowest end of the crack. Space the ports to ensure epoxy saturation of the full depth of the crack before the epoxy flows out of the next port. Do not exceed a 12-in. spacing between ports.
 - 1. Bonded Flush-fitting Ports.** Bond the port over the center of the crack with sealing epoxy and ensure the port opening is not blocked.
 - 2. Vacuum-drilled and Inserted Ports.** Drill a hole following the crack using a vacuum chuck or core bit for a depth of 1/2 in. to 3/4 in. Remove all debris from the hole before inserting the port. Anchor the entry port using surface-sealing epoxy.
- C. Surface Crack Sealing.** Seal the exterior of the crack with surface-sealing epoxy before injection. Do not block the injection ports with epoxy. Allow the surface-sealing epoxy to cure at least 6 hours or as recommended by the manufacturer.
- D. Epoxy Injection.** Inject epoxy using positive displacement pumps, an air- or hand-actuated caulking gun, or a paint pressure pot. Provide a drip-free connection between the injection nozzle and the injection port. Inject the epoxy at the lowest pressure necessary to completely fill the crack. Do not exceed an injection pressure of 15 psi, unless otherwise approved. Start the injection at the lowest elevation port and inject epoxy into each port working to the highest port. Inject epoxy in each port until the epoxy begins to run out of the adjacent port. Remove the injection nozzle, seal the port, and begin injecting in the adjacent port. If the epoxy begins to flow out of a nonadjacent port, temporarily plug that port until the epoxy begins to flow out of the adjacent port. Intermittently remove the temporary plug at a nonadjacent port to ensure epoxy flow through the crack. Inject epoxy within 10 seconds of mixing. Sample epoxy from the injection nozzle at the beginning of injection operations and at selected intervals to verify proper epoxy

780.5 to 784.4

mixing and equipment operation. For cracks wider than 1/4 in., a filler (fine aggregate) may be added to modify the epoxy if the mixture will flow from the adjacent port and is approved. The quality of work may be verified in accordance with Article 5.7, "Inspection," using core testing.

- E. Crack Surface Finishing.** Remove all epoxy from the concrete surface by grinding or other approved methods. Finish the surface of the cracks flush with the adjacent concrete surfaces with no indentations or evidence of port fittings.

780.5. Measurement. This Item will be measured by the foot of exterior crack length, by the injected gallon, or by the lump sum.

780.6. Payment. The work performed and the materials furnished in accordance with this Item and measured as provided under "Measurement" will be paid for at the unit price bid for "Epoxy Injection" of the type specified. This price is full compensation for epoxy injection, saw-cutting, materials, equipment, labor, tools, and incidentals.

ITEM 784

REPAIRING STEEL BRIDGE MEMBERS

784.1. Description. Repair steel bridge members such as beams, girders, diaphragms, trusses, and piling.

784.2. Materials. Furnish materials conforming to the following:

- Epoxy in accordance with DMS-6100, "Epoxies and Adhesives,"
- Grout in accordance with Item 421, "Hydraulic Cement Concrete,"
- Replacement steel in accordance with Item 442, "Metal for Structures," and
- Paint in accordance with Item 446, "Cleaning and Painting Steel."

784.3. Equipment. Provide equipment, including restraining equipment when required, capable of indicating the amount of force applied.

784.4. Work Requirements. Repair or replace steel bridge members in accordance with the plans. Submit a plan that includes the repair method, application of heat and restraint, material, temporary bracing or shoring, and equipment. Obtain approval of the plan before beginning work. Field-weld in accordance with Item 448, "Structural Field Welding." Perform heat straightening using welding personnel certified for unlimited thickness and

all positions in accordance with Item 448. Perform shop fabrication in accordance with Item 441, "Steel Structures."

- A. Heat Straightening.** Return all distorted members to their original section, tilt, and straightness by heat straightening. Use approved mechanical devices to restrain the member while applying heat to straighten the distorted metal. Do not use mechanical forces to straighten or bend the metal. Do not apply impact loads such as hammer blows. Repair minor dents, nicks, and gouges by grinding the defect to an acceptable contour and appearance with all corners rounded to a 1/16-in. radius. Grind so that the finished grinding marks run in the direction of the applied stresses. Straighten steel members to the tolerances of Table 1.

Table 1
Straightening Tolerances

Greatest Cross-Section Dimension	Maximum Cross-Section Displacement	Maximum Departure from Straightness (per foot of length)
Over 36"	0.5"	0.05"
12" – 36"	0.375"	0.0375"
Under 12"	0.25"	0.025"

- 1. Restraining Force.** When jacks are used, apply and lock off load before applying heat. Limit restraining forces, applied before heating, to the values shown on the plans or as approved. Do not load the member in a manner that causes material to yield without the application of heat.
- 2. Heating process.** Do not exceed the maximum allowable temperatures shown in Table 2 when applying heat to steel.

Table 2
Maximum Temperature Limits for Heat Application

Grade	Maximum Temperature (°F)
36	1,200
50, 50S, 50W, HPS 50W	1,200
HPS 70W, Q&T and TMCP	1,100
100/100W and HPS 100/100W	1,100

Use only orifice tips, and proportion tip size to the thickness of the material. Manipulate heating torches to guard against overheating. When vee or rectangular heat patterns are used, mark the patterns

784.5 to 784.6

on the steel prior to heating. Bring steel within the planned temperature as rapidly as possible without overheating. Guard against buckling when heating relatively thin, wide plates. Closely monitor temperatures with temperature-sensitive crayons, pyrometers, or infrared non-contact thermometers. Measure the temperature 5–10 seconds after the heating flame leaves the area to be tested.

3. **Cooling.** Cooling with dry compressed air after the steel has cooled to below 600°F is permitted. Do not cool the steel with water or mist. Allow the steel to cool to below 250°F before applying another set of heating patterns.
- B. Section Replacement.** Replace sections of steel members as shown on the plans or as approved.
 - C. Bearing Establishment.** Repair areas of incomplete bearing between the slab and the beam by epoxy injection in accordance with Item 780, “Epoxy Injection,” or placement of a grout mixture in accordance with Item 421, “Hydraulic Cement Concrete,” as directed.
 - D. Painting.** Complete repairs before painting. Paint repaired area only, unless otherwise shown on plans, in accordance with Item 446, “Cleaning and Painting Steel.” Use System II unless otherwise shown on the plans. Match the color of the existing appearance coating.

784.5. Measurement. This Item will be measured by each repaired member or by lump sum for the entire bridge. A member is defined as one of the following individual components:

- steel beam or girder over the length of 1 span, unless otherwise shown on the plans;
- diaphragm and its connecting hardware between adjacent steel beams;
- truss vertical;
- truss diagonal;
- truss sway brace;
- piling; or
- other elements shown on the plans.

784.6. Payment. The work performed and materials furnished in accordance with this Item and measured as provided under “Measurement” will be paid for at the unit price bid for “Repairing Steel Bridge Members” of the component specified when measured by each member, or for “Repairing Steel Bridge Members” when measured by lump sum. This price is full compensation for repairing steel bridge members and for steel, grout, epoxy, materials, equipment, labor, tools, and incidentals.

No additional payment will be made if the Contractor elects to replace a member indicated to be repaired.

ITEM 788

CONCRETE BEAM REPAIR

788.1. Description. Repair damaged beams. Beam damage may include delamination, surface spalling, section loss, and cracking.

788.2. Materials. Submit a schedule of repair materials for approval. Trial batches of the concrete and crack injection material may be required to verify their ability to perform satisfactorily.

Furnish materials meeting the pertinent requirement of the following:

- Item 426, “Prestressing”
- Item 429, “Concrete Structure Repair”
- Item 441, “Steel Structures”
- Item 442, “Metal for Structures”
- Item 780, “Epoxy Injection.”

788.3. Equipment. Provide equipment in accordance with Item 429, “Concrete Structure Repair” and Item 780, “Epoxy Injection” or as approved.

788.4. Work Methods. Repair damaged concrete beams by patching spalls and injecting cracks as shown on the plans or as directed. Perform the following work in accordance with Item 429, “Concrete Structure Repair,” with Item 780, “Epoxy Injection,” or as directed:

- If shown on the plans, preload the damaged beam before repair work. Preload with a loaded 10-yd. dump truck or other approved method. Keep the preload in place until curing requirements are complete.
- Remove damaged bridge protective assembly as directed.
- Remove damaged concrete as shown on the plans or as directed.
- Saw-cut the perimeter of the repair area.
- Prepare surface for patch.
- Insert epoxy injection tubes into cracks to be covered with repair material, when required.
- Repair damaged prestressing tendons as shown on the plans or as directed.
- Tie required reinforcing steel as shown on plans or directed.
- Install forms and ensure that the epoxy injection tubes remain accessible and functional.

788.5 to 788.6

- Apply bonding agents, apply repair material, and cure the patch areas.
- Rework or replace defective or debonded work, as directed. Required reworking of the repair work will be at the Contractor's expense.
- Inject epoxy.
- Provide an ordinary surface finish or higher class of finish, as shown on the plans, in accordance with Item 427, "Surface Finishes for Concrete."
- Apply supplemental exterior strengthening as shown on the plans.
- Repair damaged diaphragms, shown on the plans, in accordance with Item 429, "Concrete Structure Repair."
- Replace bridge protective assembly in accordance with Item 441, "Steel Structures," as shown on the plans.

The Engineer will test the quality of the work with hammer blows and any other means necessary to ensure satisfactory work. Rework the unsatisfactory repair items at the Contractor's expense.

788.5. Measurement. This Item will be measured by the each beam to be repaired.

788.6. Payment. The work performed and the materials furnished in accordance with this Item and measured as provided under "Measurement" will be paid for at the unit bid price for "Concrete Beam Repair." This price is full compensation for beam repair, epoxy injection, supplemental exterior strengthening, repairing diaphragms, removing and replacing damaged bridge protective assemblies, and furnishing equipment, labor, materials, tools, and incidentals.