

COLORADO DEPARTMENT OF TRANSPORTATION STAFF BRIDGE BRIDGE DESIGN MANUAL	Subsection: Table of Contents Effective: May 1, 2009 Supersedes: August 1, 2002
TABLE OF CONTENTS	

<b>SECTION 1 -- GENERAL POLICY AND PROVISIONS</b>		**	*
<b>1.1</b>	<b>CDOT BRIDGE DESIGN MANUAL</b>	05/01/92	3
1.1.1	General		
1.1.2	Distribution and Maintenance		
1.1.3	Revisions		
1.1.4	Supplemental Staff Bridge Publications		
	A. Staff Bridge Engineer Memorandums		
	B. CDOT Bridge Detailing Manual		
	C. CDOT Staff Bridge Worksheets		
	D. Bridge Rating Manual		
	E. Project Special Provisions		
	F. Staff Bridge BRIAR/BMS Records and Publications		
<b>1.2</b>	<b>CDOT STAFF BRIDGE WORKSHEETS</b>	05/01/92	2
1.2.1	General		
1.2.2	Distribution and Maintenance		
1.2.3	Revisions		
<b>1.3</b>	<b>PROJECT SPECIAL PROVISIONS</b>	05/01/92	2
1.3.1	General		
1.3.2	Distribution and Maintenance		
1.3.3	Revisions		
<b>SECTION 2 -- CLEARANCES AND GENERAL FEATURES OF DESIGN</b>			
<b>2.1</b>	<b>BRIDGE RAILS</b>	05/01/92	2
2.1.1	Bridges Carrying Federal-Aid Routes		
2.1.2	Bridges Over, Without Direct Access by, a Federal-Aid Route		
2.1.3	Bridges Over, With Direct Access by, a Federal-Aid Route		
<b>2.2</b>	<b>PEDESTRIAN BRIDGES AND PEDESTRIAN WALKWAYS</b>	11/01/99	4
2.2.1	Reference		
2.2.2	Width and Clearance		
2.2.3	Ramps		
2.2.4	Lighting		
2.2.5	Pedestrian Railings		
2.2.6	Chain Link Fence		
2.2.7	Bicycle Railing		
2.2.8	Deflection and Loads		
<b>2.3</b>	<b>BRIDGE TYPICAL SECTIONS AND MINIMUM CLEARANCES</b>	05/01/92	8
<b>2.4</b>	<b>RAILROAD CLEARANCES</b>	08/01/02	9
2.4.1	Revision		
2.4.2	References		
2.4.3	General		
<b>2.5</b>	<b>PROTECTIVE SCREENING, SPLASHBOARDS, AND DRAINS OVER RAILROADS</b>	07/20/88	2
<b>2.6</b>	<b>WIDTH OF ABUTMENT BERM</b>	12/12/88	1
<b>2.7</b>	<b>ACCESS FOR INSPECTION</b>	05/01/92	3
2.7.1	General		
2.7.2	Steel and Concrete Box Girders		

\* Number of pages.

\*\* Effective date, mo/day/yr

**SECTION 3 -- DESIGN CRITERIA AND LOADS**

<b>3.1</b>	<b>STRUCTURAL CAPACITY</b>	11/05/91	2
3.1.1	General		
3.1.2	Construction		
3.1.3	Seismic		
3.1.4	Superstructure Buoyancy		
<b>3.2</b>	<b>COLORADO PERMIT VEHICLE</b>	11/01/99	3
<b>3.3</b>	<b>COLLISION LOAD (CT)</b>	05/01/09	5
3.3.1	New Structures		
3.3.2	Temporary Works		
3.3.3	Existing Structures		

**SECTION 4 -- FOUNDATIONS**

<b>4.1</b>	<b>PILING</b>	11/02/87	2
4.1.1	General		
4.1.2	Spacing		
4.1.3	Orientation		
<b>4.2</b>	<b>CAISSON DESIGN</b>	04/01/91	1

**SECTION 5 -- RETAINING WALLS**

<b>5.1</b>	<b>EARTH RETAINING WALL DESIGN REQUIREMENTS</b>	10/01/91	6
5.1.1	General Requirements for All Wall Types		
	A. General		
	B. Wall Types and Selection Study Report		
	C. Wall Default Design and Design Alternatives		
	D. Objectives and Constraints of Retaining Wall Design Project		
	E. Geology Reports and Request of Additional Boring Logs		
	F. Wall Design Based on Plane Strain Condition		
	G. Bridge Abutment Wall		
	H. Quality Assurance of Wall Design and Construction		
5.1.2	Concrete Cantilever Retaining Wall		
	A. Top of Wall		
	B. Footing Sloped or Stepped		
	C. Footing Pressure		
	D. Footing Cover		
	E. Gutter		
	F. Equivalent Fluid Weight		
5.1.3	Earth Wall (M.S.E. Walls and Soil Nailing Walls)		
	A. Construction and Erection		
	B. Wall Facing		
	C. Impervious Membrane		
	D. Drainage Blanket		
	E. Fill Material of Metallic Reinforced Zone		
	F. Corrosion Protection of Carbon Steel Reinforcements		
	G. Limitations on Soil Nailing Wall		
	H. Durability of Polymeric Reinforcements		
	I. Fill Material of Polymeric Reinforced Zone		
	J. Quality Assurance of Construction		
<b>5.2</b>	<b>CDOT PROCEDURES OF PROPRIETARY WALL APPROVAL</b>	10/01/91	5
<b>5.3</b>	<b>EARTH RETAINING WALL CLASSIFICATION</b>	10/01/91	3

<b>5.4</b>	<b>WALL SELECTION FACTORS AND PROCEDURE</b>	05/01/92	9
5.4.1	Spatial Constraints		
5.4.2	Behavior Constraints		
5.4.3	Economic Considerations		
5.4.4	Evaluation Factors Used on Selected Conceptual Wall Designs		
5.4.5	Notes on Rating of Evaluation Factors		
<b>5.5</b>	<b>WORKSHEETS FOR EARTH RETAINING WALL TYPE SELECTION</b>	10/01/91	5
<b>5.6</b>	<b>EARTH RETAINING WALL MEASUREMENT AND PAYMENT</b>	10/01/91	1
<b>5.7</b>	<b>REQUIREMENTS FOR CONSTRUCTION OF ALTERNATE WALL</b>	10/01/91	2
<b>5.8</b>	<b>REQUIREMENTS FOR ASSIGNING ALTERNATE WALLS</b>	05/01/92	3
<b>5.9</b>	<b>DESIGN PROCEDURES OF A CANTILEVER RETAINING WALL</b>	10/01/91	7
<b>SECTION 6 -- CULVERTS</b>			
<b>SECTION 7 -- SUBSTRUCTURES</b>			
<b>7.1</b>	<b>WINGWALLS FOR U-TYPE ABUTMENTS</b>	11/02/87	4
7.1.1	Wingwall Design Length		
7.1.2	Wingwall Foundation Support		
7.1.3	Wingwall Design Loads		
<b>7.2</b>	<b>INTEGRAL ABUTMENTS</b>	11/01/99	3
<b>7.3</b>	<b>USE OF APPROACH SLAB</b>	05/01/92	1
<b>SECTION 8 -- REINFORCED CONCRETE</b>			
<b>8.1</b>	<b>REINFORCEMENT</b>	06/20/89	6
8.1.1	Revision		
8.1.2	General		
8.1.3	Epoxy Coated Reinforcing		
	A. Background		
	B. Policy		
	C. Bond and Basic Development Length of Epoxy Coated Reinforcing		
	D. Splice Lengths for Epoxy Coated Reinforcing		
<b>8.2</b>	<b>CONCRETE BRIDGE DECKS</b>	12/27/91	8
8.2.1	General		
8.2.2	Waterproofing Membrane		
8.2.3	Permanent Deck Forms		
8.2.4	Overhangs		
8.2.5	Design		
<b>8.3</b>	<b>CONCRETE DECKS FOR DOUBLE TEES AND PRECAST BOX GIRDERS</b>	12/27/91	2
8.3.1	Composite Double Tees and Precast Box Girders		
8.3.2	Noncomposite Double Tees and Precast Box Girders		
<b>8.4</b>	<b>GIRDERS</b>	05/01/92	1
8.4.1	General		
8.4.2	C.I.P. Concrete Box Girders		
<b>8.5</b>	<b>PIER CAP REINFORCING DETAILS</b>	12/31/87	3
8.5.1	Integral Pier Caps for C.I.P. Girders		
8.5.2	Pier Caps for Steel and Precast Girders		
<b>8.6</b>	<b>SPIRALS FOR ROUND COLUMNS</b>	05/01/92	1

**SECTION 9 -- PRESTRESSED CONCRETE**

<b>9.1</b>	<b>DESIGN OF PRESTRESSED BRIDGES</b>	08/01/02	11
9.1.1	General		
9.1.2	Cast-in-Place or Post-tensioned		
9.1.3	Precast or Pretensioned		
<b>9.2</b>	<b>PRECAST PRESTRESSED CONCRETE COMPOSITE BRIDGE DECK PANELS</b>	11/04/91	1
<b>9.3</b>	<b>PRECAST GIRDER DESIGN AIDS</b>	06/01/98	5

**SECTION 10 -- STEEL STRUCTURES**

<b>10.1</b>	<b>DESIGN OF STEEL BRIDGES</b>	11/05/91	12
10.1.1	General		
10.1.2	Materials		
10.1.3	Cover Plates		
10.1.4	Welded Girders		
10.1.5	Fatigue		
10.1.6	Stiffeners		
10.1.7	Bearing Stiffeners		
10.1.8	Splices		
10.1.9	Connections		
10.1.10	Shear Studs		
10.1.11	Control Dimension		
<b>10.2</b>	<b>BRACING FOR STEEL GIRDERS</b>	11/05/91	4
10.2.1	General		
10.2.2	Diaphragms		
10.2.3	Additional Requirements for Box Girders		
<b>10.3</b>	<b>STRUCTURAL STEEL FRACTURE CRITICAL MEMBERS</b>	11/05/91	3
<b>10.4</b>	<b>AASHTO AND ASTM STRUCTURAL STEEL DESIGNATIONS</b>	08/18/89	1

**SECTION 13 -- TIMBER STRUCTURES**

**SECTION 14 -- BEARINGS**

<b>14.1</b>	<b>BRIDGE BEARING FORCES</b>	01/01/90	1
14.1.1	Downward Force		
14.1.2	Transverse Force		
14.1.3	Longitudinal Force		
14.1.4	Uplift Force		
14.1.5	Other Forces		
<b>14.2</b>	<b>BEARING DEVICE TYPE I AND TYPE IV</b>	08/01/02	2
<b>14.3</b>	<b>BEARING DEVICE TYPE II AND TYPE V</b>	05/20/91	1
<b>14.4</b>	<b>BEARING DEVICE TYPE III</b>	10/31/88	1

**SECTION 15 -- JOINTS**

<b>15.1</b>	<b>BRIDGE DECK EXPANSION JOINTS</b>	06/01/98	1
<b>15.2</b>	<b>DESIGN PROCEDURE FOR 0" TO 4" EXPANSION DEVICE</b>	12/12/88	5
<b>15.3</b>	<b>DESIGN PROCEDURE FOR MODULAR EXPANSION DEVICE</b>	07/10/89	4

**SECTION 16 -- HYDRAULICS AND DRAINAGE**

<b>16.1</b>	<b>BRIDGE DRAINAGE</b>	11/01/99	2
<b>16.2</b>	<b>DECK DRAINS</b>	12/27/91	1
<b>16.3</b>	<b>SCOUR</b>	05/01/92	1

**SECTION 17 -- UTILITIES, LIGHTING, AND SIGNS**

<b>17.1</b>	<b>TELEPHONE CONDUITS</b>	03/20/89	1
<b>17.2</b>	<b>UTILITY BLOCKOUTS</b>	04/10/00	2
<b>17.3</b>	<b>BRIDGE LIGHTING</b>	01/01/90	1
17.3.1	Top Mounted		
17.3.2	Underneath		
<b>17.4</b>	<b>SIGNS</b>	03/06/00	3
17.4.1	Project Procedures		
17.4.2	Minimum Design Requirements		
17.4.3	Bridge-Mounted Sign Structures		
	A. Design Considerations		
	B. Geometrics		
	C. Aesthetics		
	D. Sign Placement		
	E. Installation		

**SECTION 18 -- QUANTITIES AND COST ESTIMATING**

<b>18.1</b>	<b>COST ESTIMATING</b>	11/01/90	2
18.1.1	General		
18.1.2	Conceptual Stage		
18.1.3	Preliminary Plan Stage		
18.1.4	Design Stage		
18.1.5	Bid Proposal Stage		
<b>18.2</b>	<b>COMPUTATION OF QUANTITIES</b>	01/01/90	2
18.2.1	Responsibilities		
18.2.2	Procedure for Computation		
18.2.3	Data Source		
18.2.4	Accuracy		
18.2.5	Format		
<b>18.3</b>	<b>BID ITEMS AND QUANTITIES</b>	03/20/89	1
18.3.1	Bid Items and Pay Units		
18.3.2	Quantities and Quantity Calculations		

**SECTION 19 -- PROJECT PROCEDURES AND PROCESSES**

<b>19.1</b>	<b>MINIMUM PROJECT REQUIREMENTS FOR MAJOR STRUCTURES</b>	08/01/02	10
19.1.1	General Project Requirements for Major Structures		
	A. Standards		
	B. Project Structural Engineer		
	C. Structure Reviewer		
	D. Structure Status Meetings		
	E. Exceptions		
19.1.2	Project Scoping for Major Structures		
	A. Scoping		
	B. Schedule and Workhour Estimates		
	C. Project Survey Request		
19.1.3	Major Structure Preliminary Design		
	A. Structure Data Collection		
	B. Structure Layout and Type Study		
	C. Structure Selection Report		
	D. Foundation Investigation Request		
	E. FIR		

19.1.4	Major Structure Final Design		
	A. Structural Final Design & Preparation of Plans and Specifications		
	B. Independent Design, Detail, and Quantity Check		
	C. FOR		
	D. Bridge Rating and Field Packages		
	E. Final Design Submittal		
19.1.5	Major Structure Construction		
	A. Assisting the Project Engineer		
	B. Outside Inquires		
	C. Contractor Drawing Submittals		
	D. As Constructed Plans		
19.1.6	Standards for the Design and Construction of Structures		
	A. Standards Published by Staff Bridge		
	B. Standards Published Outside of Staff Bridge		
	C. Standards Published Outside of CDOT		
19.1.7	Major Project Milestones		
19.1.8	Definitions		
<b>19.2</b>	<b>CONTRACTOR DRAWING SUBMITTALS</b>	06/01/98	3
<b>19.3</b>	<b>SELECTING BRIDGES FOR REHABILITATION OR REPLACEMENT</b>	05/01/92	1
<b>19.4</b>	<b>COORDINATION WITH HYDRAULICS DESIGN UNIT</b>	05/01/92	2
<b>19.5</b>	<b>OVERLAYS</b>	04/10/00	1

COLORADO DEPARTMENT OF TRANSPORTATION STAFF BRIDGE BRIDGE DESIGN MANUAL	Subsection: Revision Log Effective: May 1, 2009 Supersedes: August 1, 2002
REVISION LOG	

This revision log is a record of all the revisions to the Bridge Design Manual since October 1987. It shows the date of the current and previous versions of each Subsection, and the initials of the persons who wrote the Subsection for the Staff Bridge Engineer.

**SECTION 1 - GENERAL POLICY AND PROVISIONS**

- 1.1 CDOT BRIDGE DESIGN MANUAL  
05/92 MAL 01/90 DJS 03/89 SLW
- 1.2 CDOT STAFF BRIDGE WORKSHEETS  
05/92 MAL
- 1.3 PROJECT SPECIAL PROVISIONS  
05/92 MAL

**SECTION 2 - CLEARANCE AND GENERAL FEATURES OF DESIGN**

- 2.1 BRIDGE RAILS  
05/92 AJS
- 2.2 PEDESTRIAN BRIDGES AND PEDESTRIAN WALKWAYS  
11/99 RLO/MAL 03/89 RWS 12/87 RWS
- 2.3 BRIDGE TYPICAL SECTIONS AND MINIMUM CLEARANCES  
05/92 MAL 07/88 SLW
- 2.4 RAILROAD CLEARANCES  
08/02 PJM 03/89 SLW 07/88 SLW
- 2.5 PROTECTIVE SCREENING, SPLASHBOARDS, AND DRAINS OVER RAILROADS  
07/88 SLW
- 2.6 WIDTH OF ABUTMENT BERM  
12/88 RWS
- 2.7 ACCESS FOR INSPECTION  
05/92 MAL 11/91 MAL

**SECTION 3 - DESIGN CRITERIA AND LOADS**

- 3.1 STRUCTURAL CAPACITY  
11/91 MAL 12/87 RWS
- 3.2 COLORADO PERMIT VEHICLE  
11/99 MLM 05/92 MLM 07/88 MLM
- 3.3 COLLISION LOAD (CT)  
05/2009 MLM

**SECTION 4 - FOUNDATIONS**

- 4.1 PILING  
11/87 BLP/RWS
- 4.2 CAISSON DESIGN  
04/91 JMD

**SECTION 5 - RETAINING WALLS**

- 5.1 EARTH RETAINING WALL DESIGN REQUIREMENTS  
10/91 STW 12/90 STW 11/87 RWS
- 5.2 CDOT PROCEDURES OF PROPRIETARY WALL APPROVAL  
10/91 STW 12/90 STW
- 5.3 EARTH RETAINING WALL CLASSIFICATION  
10/91 STW 12/90 STW
- 5.4 WALL SELECTION FACTORS AND PROCEDURES  
05/92 STW 10/91 STW 12/90 STW
- 5.5 WORKSHEETS FOR EARTH RETAINING WALL TYPE SELECTION  
10/91 STW 12/90 STW
- 5.6 EARTH RETAINING WALL MEASUREMENT AND PAYMENT  
10/91 STW
- 5.7 REQUIREMENTS FOR CONSTRUCTION OF ALTERNATE WALLS  
10/91 STW
- 5.8 REQUIREMENTS FOR ASSIGNING ALTERNATE WALLS  
05/92 STW 10/91 STW
- 5.9 DESIGN PROCEDURES OF A CANTILEVER RETAINING WALL  
10/91 STW

**SECTION 6 - CULVERTS****SECTION 7 - SUBSTRUCTURES**

- 7.1 WINGWALLS FOR U-TYPE ABUTMENTS  
11/87 RWS
- 7.2 INTEGRAL ABUTMENTS  
11/99 MLM 12/87 TCF/SLW
- 7.3 USE OF APPROACH SLAB  
05/92 MAL 12/87 TCF/SLW



**SECTION 8 - REINFORCED CONCRETE**

- 8.1 REINFORCED CONCRETE  
06/89 MH 12/87 SLW
- 8.2 CONCRETE BRIDGE DECKS  
12/91 MH 12/87 SLW/TCF
- 8.3 CONCRETE DECK FOR DOUBLE TREE AND PRECAST BOX GIRDERS  
12/91 MH 12/87 SLW
- 8.4 GIRDERS  
05/92 MAL 12/87 TCF/SLW
- 8.5 PIER CAP REINFORCING DETAILS  
12/87 TCS/SLW
- 8.6 SPIRALS FOR ROUND COLUMNS  
05/92 AJS

**SECTION 9 - PRESTRESSED CONCRETE**

- 9.1 DESIGN OF PRESTRESSED BRIDGES  
08/02 MLM 06/98 MLM 05/92 MLM/MAL 03/89 MLM 10/87 MLM
- 9.2 PRECAST PRESTRESSED CONCRETE COMPOSITE BRIDGE DECK PANELS  
11/91 MH/BLP
- 9.3 PRECAST GIRDER DESIGN AIDS  
06/98 MLM

**SECTION 10 - STEEL STRUCTURES**

- 10.1 DESIGN OF STEEL BRIDGES  
11/91 MAL 01/88 MC
- 10.2 BRACING FOR STEEL GIRDERS  
11/91 MAL 01/88 MC
- 10.3 STRUCTURAL STEEL FRACTURE CRITICAL MEMBERS  
11/91 MAL
- 10.4 AASHTO AND ASTM STRUCTURAL DESIGNATIONS  
08/89 RRA

**SECTION 13 - TIMBER STRUCTURES**

**SECTION 14 - BEARINGS**

- 14.1 BRIDGE BEARING FORCES  
01/90 DJS
- 14.2 BEARING DEVICE TYPE I AND TYPE IV  
08/02 RLO 05/92 MH 05/91 BLP 10/88 PKP/DLD
- 14.3 BEARING DEVICE TYPE II AND TYPE V  
05/91 BLP 10/88 PKP/DLD
- 14.4 BEARING DEVICE TYPE III  
10/88 BLP

**SECTION 15 - JOINTS**

- 15.1 BRIDGE DECK EXPANSION JOINTS  
06/98 SLW 05/92 MAL 12/88 MAL
- 15.2 DESIGN PROCEDURE FOR 0" TO 4" EXPANSION DEVICE  
12/88 GSM
- 15.3 DESIGN PROCEDURE FOR MODULAR EXPANSION DEVICE  
07/89 BLP

**SECTION 16 - HYDRAULICS AND DRAINAGE**

- 16.1 BRIDGE DRAINAGE  
11/99 DEC 01/90 PJM/AJS
- 16.2 DECK DRAINS  
12/91 MH 12/87 TCF/SLW
- 16.3 SCOUR  
05/92 AJS

**SECTION 17 - UTILITIES, LIGHTING, AND SIGNS**

- 17.1 TELEPHONE CONDUITS  
03/89 DJS
- 17.2 UTILITY BLOCKOUTS  
04/00 DEC 07/88 DJS
- 17.3 BRIDGE LIGHTING  
01/90 DJS
- 17.4 SIGNS  
03/00 RLO 10/98 RLO 01/90 DJS

**SECTION 18 - QUANTITIES AND COST ESTIMATING**

- 18.1 COST ESTIMATING  
01/90 DJS
- 18.2 COMPUTATION OF QUANTITIES  
01/90 DJS
- 18.3 BID ITEMS AND QUANTITIES  
03/89 EHH

**SECTION 19 - PROJECT PROCEDURES AND PROCESSES**

- 19.1 MINIMUM PROJECT REQUIREMENTS FOR MAJOR STRUCTURES  
08/02 RLO 04/00 RLO/MAL 06/98 MAL 01/90 DJS
- 19.2 CONTRACTOR DRAWING SUBMITTALS  
06/98 MAL 05/92 AJS
- 19.3 SELECTING BRIDGES FOR REHABILITATION OR REPLACEMENT  
05/92 RRA
- 19.4 COORDINATION WITH HYDRAULICS DESIGN UNIT  
05/92 RJS
- 19.5 OVERLAYS  
04/00 RLO 01/90 DJS

CDOT BRIDGE DESIGN MANUAL

---

### **1.1.1 GENERAL**

The Colorado Department of Transportation Bridge Design Manual provides the policy and procedures currently in effect for the design of bridges and other highway structures on the state highway system and on federally funded off-system projects.

The current AASHTO Standard Specifications for Highway Bridges is the basic document guiding the design of highway structures. The CDOT Bridge Design Manual supplements the AASHTO specifications by providing additional direction. Where discrepancy arises between this manual and the current AASHTO Specifications for Bridges, this manual will control.

Other specifications may be required for structural design, but only as referenced by this manual or the AASHTO Standard Specifications. For example, this manual and the AASHTO Standard Specifications reference the ANSI/AASHTO/AWS D1.5 Bridge Welding Code.

Using this manual does not relieve engineers of their responsibility to provide an adequate final design or to exercise sound engineering judgment. The Staff Bridge Engineer will consider requests to vary from the policies given in this manual when warranted by special conditions and sound engineering judgment. If different interpretations of a given article arise, guidance shall be obtained from the Staff Bridge Engineer or his designee. This manual is issued by the Staff Bridge Engineer and all modifications and variances must be authorized by him or his designee.

A thorough acquaintance with the contents of the Bridge Design Manual is essential for anyone designing structures for the CDOT or for federally funded off-system projects.

Previous editions of the CDOT Bridge Design Manual were titled, or referred to as, "Bridge Manual Volume I", "Bridge Design Policy Memos", "Policy Letters", and "Design Policy and Procedure Manual". These previous editions and titles are now void.

### **1.1.2 DISTRIBUTION AND MAINTENANCE**

Copies of the Bridge Design Manual are obtained from the office of the Staff Bridge Engineer or from Staff Bridge Unit 01224.

The Staff Bridge Engineer's office is responsible for maintaining the computer files and hard-copy originals containing the Design Manual. Staff Bridge Unit 01224 is responsible for coordinating revisions and making copies and updates available. Unit 01224 will also maintain a revision log showing all the revision dates that have transpired for each Subsection and the person who wrote the revision.

Before starting a structural design project, the engineers involved shall obtain a copy of the Design Manual from Unit 01224; or, if they already have a manual, shall inspect a copy of the current table of contents provided by Unit 01224 to make certain their copy of the manual is up-to-date.

### 1.1.3 REVISIONS

The Bridge Design Manual is intended to be dynamic. It will continuously incorporate revisions as new material is added and as criteria and specifications change. All revisions shall be approved by, and transmitted from, the office of the Staff Bridge Engineer.

Suggestions for improving and updating the manual are encouraged. Anyone who wishes to propose revisions should informally discuss their changes with other bridge engineers to further develop and refine their ideas. The Staff Bridge Engineer should then be presented with a preliminary draft showing the developed concept.

Alternatively, proposed revisions may be submitted to the Staff Bridge Preconstruction Engineer, or the Staff Bridge unit leader of Unit 01224, who will then present the revisions to the Staff Bridge Engineer.

On deciding to pursue the revisions, the Staff Bridge Engineer will assign them to an engineer. The engineer receiving the assignment is responsible for the final writing, distributing the revisions to all Staff Bridge personnel for their review and comment, making revisions as appropriate based on the comments received, and submitting the final draft to the Staff Bridge Engineer for approval.

Revisions will be made by Subsection. That is, whenever a revision is made, the entire Subsection containing the revision will be reissued. Whenever revisions are issued, they shall be accompanied by a cover document signed by the Staff Bridge Engineer and by an updated Table of Contents showing the new "effective dates" of the revised Subsections. The effective dates in the table of contents provide a ready means to check if a given manual is up-to-date.

### 1.1.4 SUPPLEMENTAL STAFF BRIDGE PUBLICATIONS

The following material furnished by the Staff Bridge Branch is to be used in conjunction with the CDOT Bridge Design Manual for the development of contract documents. Familiarity with the following material is essential for anyone designing structures for the CDOT or for federally funded off-system projects.

#### 1.1.4.A STAFF BRIDGE ENGINEER MEMORANDUMS

Memorandums from the Staff Bridge Engineer's office giving direction for structural design shall govern over the contents of the Bridge Design Manual and the AASHTO specifications. These memorandums are issued when expediency is required or as a means for introducing new policy and procedures. These memorandums shall be in effect for one year after their submittal unless designated otherwise by the memorandums. During the one year period the Bridge Design Manual will be revised to include the design requirements given by these memorandums unless otherwise directed by the Staff Bridge Engineer.

#### 1.1.4.B CDOT BRIDGE DETAILING MANUAL

The CDOT Bridge Detailing Manual provides the policies and procedures for developing and checking contract plans and quantities. This publication was previously referred to as the Bridge Manual Volume II, and the Bridge Detailing and Checking Manual. Copies and revisions to this manual are

obtained from the Staff Bridge Engineer's Office or from the Staff Bridge Unit 01224.

#### *1.1.4.C CDOT STAFF BRIDGE WORKSHEETS*

The CDOT Staff Bridge Worksheets are plan sheets of standardized bridge details. For further information see Subsection 1.2. In general, the CDOT Standard Plans (M & S Standards) do not provide the standard details used for bridges. There are exceptions to this. For this reason, and because structural details are often dependent on the roadway design standards, familiarity with the M & S Standards, as well as the Staff Bridge Worksheets, is essential.

#### *1.1.4.D BRIDGE RATING MANUAL*

The Bridge Rating Manual is maintained and provided by the Staff Bridge BRIAR/BMS group. This manual provides the policies and procedures for performing and submitting the structural capacity rating of bridges. All bridge designs require the submittal of a bridge rating by the design team.

#### *1.1.4.E PROJECT SPECIAL PROVISIONS*

To assist designers in preparing project special provisions, Staff Bridge maintains a file of the most commonly used structural related project special provisions. For additional information see Subsection 1.3.

#### *1.1.4.F STAFF BRIDGE BRIAR/BMS RECORDS AND PUBLICATIONS*

The records and publications maintained and provided by the Staff Bridge BRIAR/BMS group (Bridge Records, Inspection, Appraisal, Rating and Management Systems group) serve a variety of functions for structural design. Their primary use by bridge designers is for evaluating existing structures for rehabilitation or replacement. Below is a partial list of the records and publications. For further information contact the Staff Bridge BRIAR/BMS office.

*Structure Folders:* Every structure has a file whose contents include the bridge inspection reports, a list of the inventory and appraisal items, and a summary of the structural capacity rating.

*Microfilm files:* The project plans and documents for every structure are kept for the life of the structure on microfilm.

*CDOT Structure Inventory Coding Guide:* This guide lists and explains the structure inventory and appraisal items.

*Field Log of Structures:* This is a catalog of all CDOT structures listed by highway number.

CDOT STAFF BRIDGE WORKSHEETS

---

**GENERAL**

The CDOT Staff Bridge Worksheets are drawings of the department's standardized bridge details. The worksheets define bridge design policy on the details addressed. The details are directly applicable for most projects; however, project specific modifications are sometimes necessary.

These sheets were called "Bridge Standards" in the past. As such, they were occasionally used inappropriately. The current title, "Bridge Worksheets", helps establish that these are predetailed drawings that need checking on a project by project basis for applicability. The worksheet numbers are for identification only and shall be removed at the same time the designer, detailer and checkers initials are placed on the sheet.

All applications of these worksheets shall originate with a copy from the master file. The master file shall not be modified without approval of the Staff Bridge Engineer or his designee.

**DISTRIBUTION AND MAINTENANCE**

Staff Bridge Unit 01224 is responsible for coordinating revisions and making copies of the worksheets available. Unit 01224 will maintain a revision log showing all the revision dates that have transpired for each Worksheet, and the engineers and detailers who made the revisions. Unit 01224 is also responsible for maintaining the computer master file and the hard-copy master file.

The computer master file contains all of the current worksheets. It is available to Staff Bridge Personnel for read, print and copy operations only. The senior technician in Unit 01224 and his designee alone have authorization to conduct write and delete operations on this file.

The hard-copy master file contains the revision log and half-size copies of all the current worksheets. It is kept within Unit 01224 and is available to anyone for reference.

Copies from the computer master file can be obtained at any time by Staff Bridge Personnel. A few copies from the half-size hard-copy master file can be obtained at any time from Unit 01224. Obtaining full size vellums, computer files (i.e., tapes or discs), or numerous half-size copies (e.g., copies of all the worksheets), needs to be scheduled at least a day in advance with Unit 01224.

**REVISIONS**

The CDOT Staff Bridge Worksheets are intended to be dynamic. The Worksheets will continuously incorporate revisions as new material is added and as criteria and specifications change. All revisions shall be approved by the Staff Bridge Engineer or his designee.

Suggestions for improving and updating the worksheets are encouraged. Anyone who wishes to propose revisions should informally discuss their changes with other bridge engineers and detailers to further develop and refine their ideas.

The Staff Bridge Engineer should then be presented with a preliminary draft showing the developed concept.

Alternatively, proposed revisions may be submitted to the Staff Bridge Preconstruction Engineer, or the Staff Bridge unit leader of Unit 01224, who will then present the revisions to the Staff Bridge Engineer.

On deciding to pursue the revisions the Staff Bridge Engineer, or his designee, will assign them to an engineer and detailer. The engineer receiving the assignment is responsible for the final design, distributing the revisions to all Staff Bridge personnel for their review and comment, making revisions as appropriate based on the comments received, and submitting the final draft to the Staff Bridge Engineer, or his designee, for approval.

Revised and new worksheets shall have their effective date given in the lower right corner of the drawing. On receiving new and revised worksheets, Unit 01224 will update the master files and the revision log. The effective dates on the drawings and in the revision log provide a ready means to check if a given copy is up-to-date.

Engineers making revisions to the CDOT Staff Bridge Worksheets should also submit to Unit 01224 design notes documenting their revisions. These notes shall describe the changes, why they were made, and provide supporting calculations as appropriate. The notes are to be signed by the engineer and a checker.



COLORADO DEPARTMENT OF TRANSPORTATION STAFF BRIDGE BRANCH BRIDGE DESIGN MANUAL	Subsection: 1.3 Effective: May 1, 1992 Supersedes: New
--	--

---

PROJECT SPECIAL PROVISIONS

---

**GENERAL**

Contract documents are primarily composed of plan sheets and construction specifications. Structural engineers are responsible for the construction specifications, as well as the plan sheets, applicable to their structure. The construction specifications are made up of the CDOT Standard and Supplemental Specifications for Road and Bridge Construction, the Standard Special Provisions, and the Project Special Provisions.

Because the Standard Special Provisions and the Project Special Provisions take precedence over the plan sheets, it is crucial that they be carefully prepared and reviewed by the bridge designer.

Developing the Project Special Provisions is an integral part of the structure design. To assist designers Staff Bridge maintains three Project Special Provision master files (one computer master file and two duplicate hard-copy master files) of the most commonly used provisions related to structures. The provisions on file provide the Staff Bridge policy currently in effect for the subject area.

All structural related Project Special Provisions should originate with a copy from the master files, when the master files have a provision covering the subject area. The master files shall not be modified without approval of the Staff Bridge Engineer or the Staff Bridge Preconstruction Engineer.

**DISTRIBUTION AND MAINTENANCE**

The Staff Bridge Preconstruction Engineer's office is responsible for maintaining the master files, making copies of the master files available, and coordinating revisions to the master files. The Staff Bridge Preconstruction Engineer's office will also maintain a revision log with each Project Special Provision in the master files.

The revision log lists all the revisions that have transpired for the special provision by showing the date and author of the revision, accompanied by a brief explanation of the revision. Where appropriate, the explanation includes instructions on using the Project Special Provision.

The computer master file contains all of the current Project Special Provisions with their revision logs. The Staff Bridge Administrative Assistant and her designee alone have authorization to conduct write and delete operations on this file.

The hard-copy master files are two loose leaf binders kept by the Staff Bridge Engineer's office containing all of the current Project Special Provisions with their revision logs. These master files are available to anyone for reference or making copies.

**REVISIONS**

Most of the Project Provisions kept on file require little or no revision for most projects (e.g., those addressing bridge rails), while others are very project specific and require heavy revision (e.g., the alter and erect structural steel provision).

Whenever possible, revisions made to prepare a Project Special Provision for a specific project shall be made from a copy of the master files. This is necessary to minimize errors and to insure the latest policies for the subject area are accounted for.

Errors and omissions in the master files, or needed improvements, are to be reported to the Staff Bridge Preconstruction Engineer. The Staff Bridge Engineer or Preconstruction Engineer will assign the necessary changes to an engineer. The engineer receiving the assignment is responsible for the final writing, updating the revision log to include the information described above, and submitting the final draft to the Staff Bridge Preconstruction Engineer for approval and inclusion into the master files.

COLORADO DEPARTMENT OF TRANSPORTATION STAFF BRIDGE BRANCH BRIDGE DESIGN MANUAL	Subsection: 2.1 Effective: May 1, 1992 Supersedes: New
--	--

BRIDGE RAILS

POLICY	COMMENTARY
--------	------------

**2.1.1 BRIDGES CARRYING FEDERAL-AID ROUTES**

For bridges which carry Federal-aid routes, the following shall apply:

2.1.1.A Any new and/or rehabilitated bridges financed with Federal-aid funds are expected to be provided with crash-tested bridge rails. An exception to this policy can only be made for bridges to be rehabilitated by formally requesting a variance for the site based on an analysis of the following criteria:

- Existing rail type
- Condition of structure (deterioration)
- Accident history
- Traffic information (ADT, speed)
- Alignment (straight, curved)
- Replacement scheduled within the Five Year Plan

2.1.1.B Bridge rails on any existing bridges located within the limits of any Federal-aid projects are expected to be evaluated considering, at a minimum, the factors identified in 2.1.1.A. Bridge rails that meet or can be modified to meet current AASHTO specifications, but which have not been crash-tested may remain in place.

2.1.1.C The decision to leave a bridge rail in place under the conditions of 2.1.1.B is a design decision and does not require a variance approval.

2.1.1.D Should the existing railing not meet current AASHTO for reasons of inadequate height, strength or geometrics and/or is included in the Five Year Plan, a

This Subsection, 2.1, is taken directly from the Staff Bridge Engineer's 3/15/91 memorandum to the District Engineers and Branch Heads. The purpose of this 3/15/91 memorandum, which was approved by the Director of Central Engineering, was to replace the 4/18/88 memorandum from the Director of Central Engineering and to establish the Department's policies with regard to replacement and/or upgrading of bridge rails.

On 6/13/89 FHWA by publication in the Federal Register implemented a final rule on the AASHTO Guide Specifications for Bridge Rails. That publication opened up a comment period on the Guide which apparently was still open as of 3/15/91. The Federal Register published notice that the Guide was placed in 23 CFR, specifically in subsection 23 CFR 625.5, as a guide and reference. This location in 23 CFR was specifically in contrast to 23 CFR 625.4 which subsection contains Standards, Policies and Standard Specifications.

FHWA has required crash-tested rails since August 1986, to be used on all Federal-aid bridge projects which require (1) new and/or (2) reconstructed bridge rails. FHWA has not, however, taken a similarly strong position on existing rails on bridges which fall within the limits of Federal-aid projects.

May 1, 1992	Subsection No. 2.1	Page 2 of 2
POLICY		COMMENTARY

variance approval will be necessary to leave the rail in place.

**2.1.2 BRIDGES OVER, WITHOUT DIRECT ACCESS BY, A FEDERAL-AID ROUTE**

For bridges over the Federal-aid route that cannot be accessed by the traffic on the Federal-aid route; e.g., grade separations or frontage roads over the route, take either of the following actions:

2.1.2.A If no other work is being performed on the bridge with Federal funding, bridge rail upgrades are not required.

2.1.2.B If the District desires, railing may be upgraded provided the bridge carries a Federal-aid route.

**2.1.3 BRIDGES OVER, WITH DIRECT ACCESS BY, A FEDERAL-AID ROUTE**

For bridges over the Federal-aid route that can be accessed by the traffic on the Federal-aid route; e.g., interchanges, take one of the following actions:

2.1.3.A Upgrade the railing.

2.1.3.B Defer the upgrade to a later date if an upgrade of the route over is scheduled within the Five Year Plan.

2.1.3.C Evaluate a design decision for the site based on an analysis of the conditions noted in 2.1.1.B above.

COLORADO DEPARTMENT OF TRANSPORTATION STAFF BRIDGE BRIDGE DESIGN MANUAL	Subsection: 2.2 Effective: November 1, 1999 Supersedes: March 20, 1989
PEDESTRIAN BRIDGES AND PEDESTRIAN WALKWAYS	

## REFERENCE

Geometric design criteria is derived from:

- *AASHTO Policy on Geometric Design of Highways and Streets*
- *AASHTO Guide for Development of New Bicycle Facilities*
- *FHWA-RD-75-114 Safety and Location for Bicycle Facilities*
- *ADA Accessibility Guidelines, Architectural and Transportation Barriers Board, August 1991.*
- *Federal Register, Proposed Rules, December 21, 1992.*

## WIDTH AND CLEARANCE

Except for special situations, the minimum clear width for a pedestrian bridge shall be 8'-0". For an attached sidewalk on a vehicle bridge, the clear walkway shall be 4'-0" minimum, but in no case shall it be narrower than the approaching sidewalk. Additional width may be required in an urban area or for a shared pedestrian-bikeway facility.

For two-directional pedestrian traffic if the clear width is less than 5', then to meet ADA guidelines, passing spaces of at least 5' x 5' should be located at reasonable intervals, not to exceed 200'.

The minimum vertical clearance from an under-passing roadway surface to a pedestrian bridge shall be 17'-6".

The minimum vertical clearance from a pedestrian or bicycle path to an overhead obstruction shall be 8'-6", or 9'-0" for an equestrian path, measured at 1'-0" from the face of curb, parapet, or rail as shown in the sketches on page 3.

## RAMPS

Pedestrian overpass structures, if practical, may be provided with both ramps and stairways, but under no condition should a structure be built with stairs only.

Maximum grades on pedestrian bridges and approach ramps shall be 8.33%.

Landings shall be provided to accommodate a maximum rise between landings of 30 inches. The maximum spacing of landings will be 30 ft. for a 8.33% grade or 40 ft. for a 6.25% grade.

Landings are not required when the grade is 5% or less. Landings shall be level, full width of the bridge, and a minimum of 5 ft. in length.

Landings shall be provided whenever the direction of the ramp changes.

The deck shall have a non-skid surface; i.e., transverse fiber broom finish for concrete.

**LIGHTING**

Lighting for pedestrian bridges shall be provided on poles independent of the bridge structure where possible.

**PEDESTRIAN RAILINGS**

Pedestrian railings shall be designed in accordance with AASHTO Specifications.

Handrails shall be provided for all stairs and for ramps with grades greater than 5%. The rail height shall be 34 to 38 inches (per ADA guidelines) as measured from the tread at the face of the riser for stairs and from the ramp surface for ramps.

**CHAIN LINK FENCE**

Portions of pedestrian bridges or walkways over traffic shall be provided with chain link fabric or other approved fencing. The maximum size opening for chain link fabric shall be 2". Approved fencing includes the use of picket fences with a maximum clear opening of 2" between pickets. Fences shall have a minimum height of 7'-10" above the walkway surface. 7'-10" is used as the minimum instead of 8'-0" to allow use of a standard 5' wide fabric chain link fence with a standard height Bridge Rail Type 7.

In general, vertical fences shall be used. However, where warranted due to pedestrian volume or where there are recorded incidents of objects thrown from overpasses, pedestrian bridges or walkways shall be fully or partially enclosed with chain link fabric or other approved material. The enclosure shall have a minimum vertical clearance of 8'-6" at 1'-0" from the face of curb, parapet or rail as shown in the sketches on page 3.

At highway crossings, chain link fencing shall extend a minimum of 30 feet beyond the outside shoulder line on the traveled way below the bridge. The ultimate roadway section shall be used to establish fencing limits when it is available. Previously 20 feet was used for this requirement. It was increased to 30' to provide better protection from objects thrown from a vehicle, taking into consideration the forward velocity of the projectile.

**BICYCLE RAILING**

Bicycle railing shall be used on bridges specifically designed to carry bicycle traffic, and on bridges where specific protection of bicyclists is deemed necessary. The minimum height of railing used to protect a bicyclist shall be 54 inches, measured from the top of the surface on which the bicycle rides to the rail. Smooth rub rails shall be attached to the barriers at a handlebar height of 42 inches.

Chain link fence may be used in lieu of bicycle railing. However, smooth rub rails shall be attached to the fence posts at a handlebar height of 42 inches.

**DEFLECTION AND LOADS**

Design shall be in accordance with the *AASHTO Standard Specifications for Highway Bridges* except as modified by the *AASHTO Guide Specifications for Design of Pedestrian Bridges*.

Girder deflection due to design live load shall be limited to  $L/600$ . Dynamic deflection response shall be controlled by applying the vibration criteria in the *AASHTO Guide Specifications for Design of Pedestrian Bridges*.

Pedestrian/bicycle bridges shall be designed for any planned or potential use by maintenance trucks, emergency vehicles, and construction live loads. The Colorado Legal Load Type 3 Vehicle should be used for this purpose and designed for at the operating level (AASHTO Load Group IB). This will provide structural adequacy for a broad range of legal load vehicles.

If the Type 3 Legal Load has a strong effect on the bridge costs and it is clear that over the life of the bridge, the bridge will be accessed by only light maintenance and construction vehicles, then a different live load vehicle, appropriate for the situation, may be used. In no case shall the vehicle live load be less than H-5 for bridges with a clear deck width from 6' to 10', and H-10 for a clear deck width over 10'. These vehicles may be checked at the operating level. No vehicle live load is required for clear widths less than 6'.

Over the life of the bridge, the bridge may be used for different purposes, or at different locations, than originally intended. This should be considered when selecting the appropriate vehicle live load. Whenever the vehicle live load selected is less than the Type 3 Legal Load, the vehicle load capacity shall be defined on signage permanently attached to each end of the bridge. The live load used in design shall be fully defined in the plans.

The Type 3 Legal Load is a 27-ton, 3-axle vehicle with 13.5' front axle spacing, and 4' rear. The axle loads are 7 tons on the front axle and 10 tons on each of the rear axles. The H-5 and H-10 live loads are 5 and 10 ton, 2 axle, vehicles with 14' axle spacing and 80% of the total load carried by the rear axle.

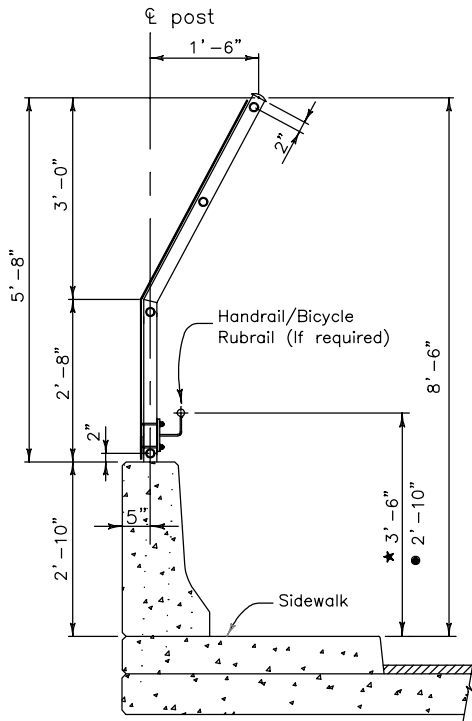

BRIDGE RAIL WITH PARTIAL ENCLOSURE

See B-607-6B for additional details.

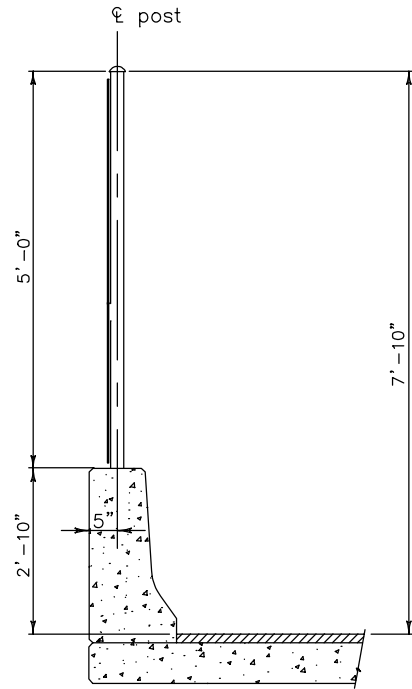

BRIDGE RAIL WITH VERTICAL FENCE

See B-607-5 for additional details.

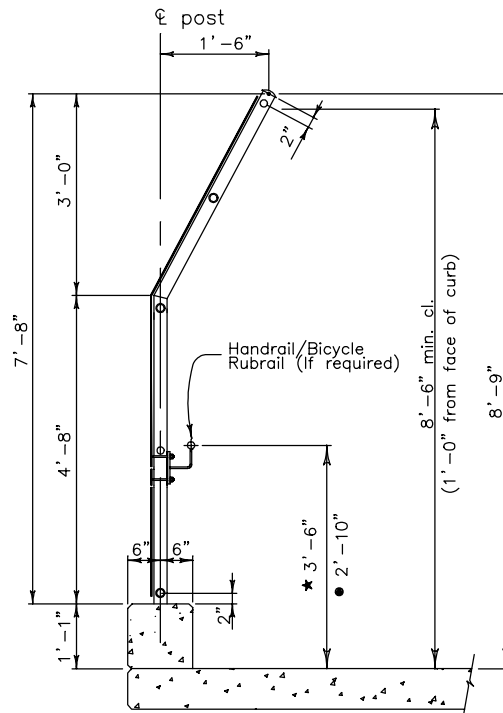

- ★ = (Bicycle Rubrail)
- = (Pedestrian Handrail)

PARTIAL ENCLOSURE

See B-607-8B for additional details



BRIDGE TYPICAL SECTIONS AND MINIMUM CLEARANCES

---

The following pages show typical bridge widths and minimum vertical and lateral clearances for various types of highways:

*Page 2* -- Typical Bridge Cross Sections. Closing the median between bridges (i.e. extending the bridge deck across the median) shall be considered and discussed with the roadway designer when the median is less than or equal to 30 feet wide. Closing the median is desirable when it leads to greater uniformity between the median treatment on the bridge and the treatment off the bridge -- this is primarily with regard to the type and location of the median barrier. Bridge inspection access, maintenance access, constructability, and safety concerns shall be considered with cost when deciding whether or not to close the median between bridges.

*Page 3* -- Standard Sidewalk Details

*Page 4* -- Lateral Clearances, Single Span Bridge, High Speed & High Volume Undercrossing, Two Lane Roadways

*Page 5* -- Lateral Clearances, Two Span Bridge, All Interstate Undercrossings, Urban & Rural, and All Other High Speed Divided Highways

*Page 6* -- Lateral Clearances, Three Span Bridge, High Speed & High Volume Undercrossings, Two Lane Roadways

*Page 7* -- Lateral Clearances, Four or Five Span Bridge, All Interstate Undercrossings, Urban & Rural, and All Other High Speed Divided Highways

*Page 8* -- Lateral Clearances, Low Speed & Low Volume Undercrossings, Two Lane Roadways

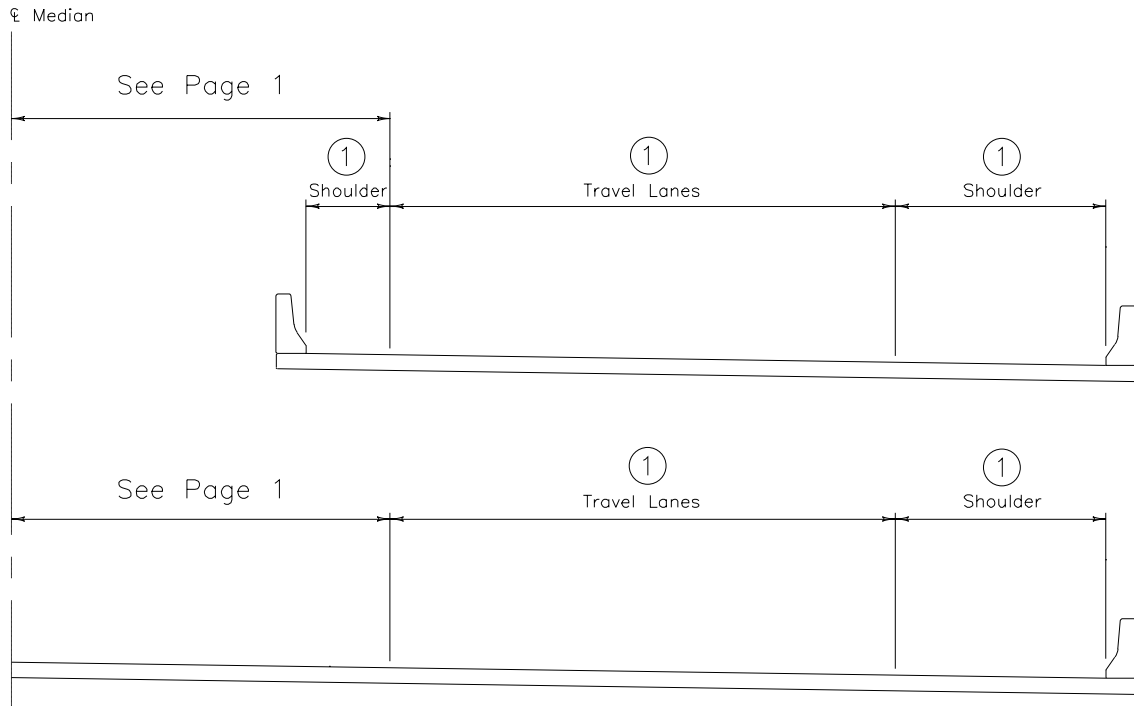

DIVIDED HIGHWAYS

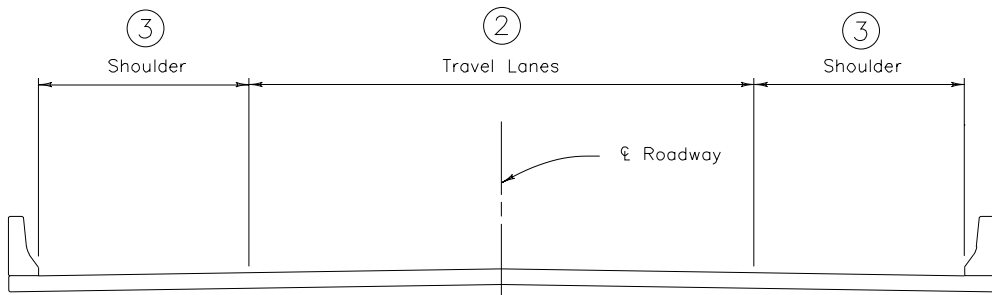

CROWNED SECTION

TYPICAL BRIDGE CROSS-SECTIONS

- ① Refer to Roadway Typical Sections.
- ② Travel lane widths are based on ADT. Refer to Roadway Typical Sections.
- ③ Full roadway shoulder plus 2 feet for shoulders less than 8 feet wide.  
Full roadway shoulder only for shoulders 8 feet or wider.

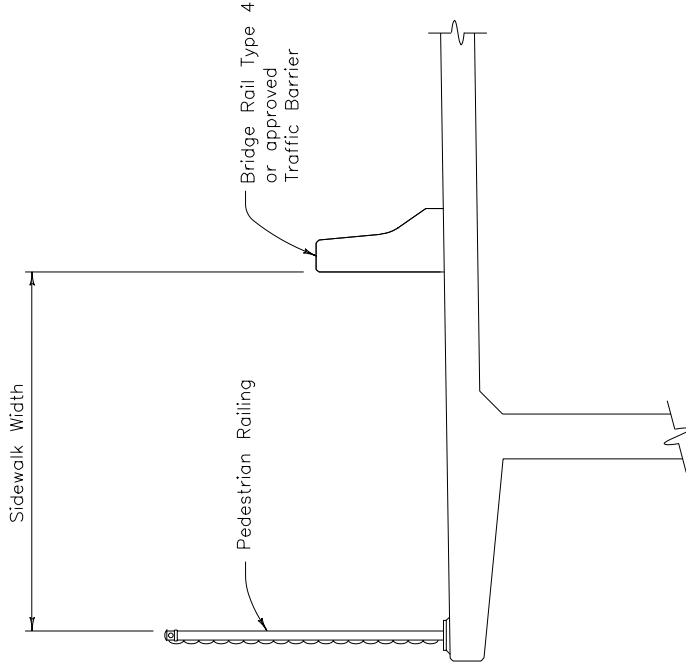

URBAN AND RURAL CROSSING

High speed, high volume roadways  
or no approach curb  
(Speed 45 MPH or greater)

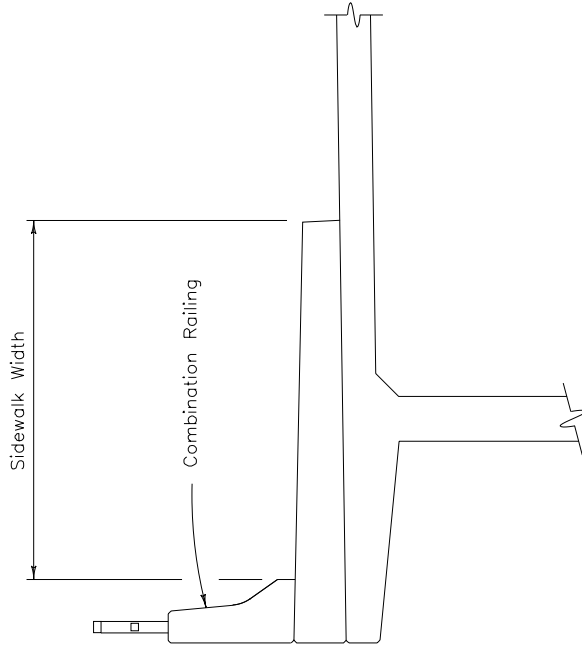

LOCAL URBAN STREET CROSSING

with approaching curb and walk  
(Speed less than 45 MPH)

STANDARD SIDEWALK DETAILS

Reference: Staff Design Bulletin 84-1, July 1984

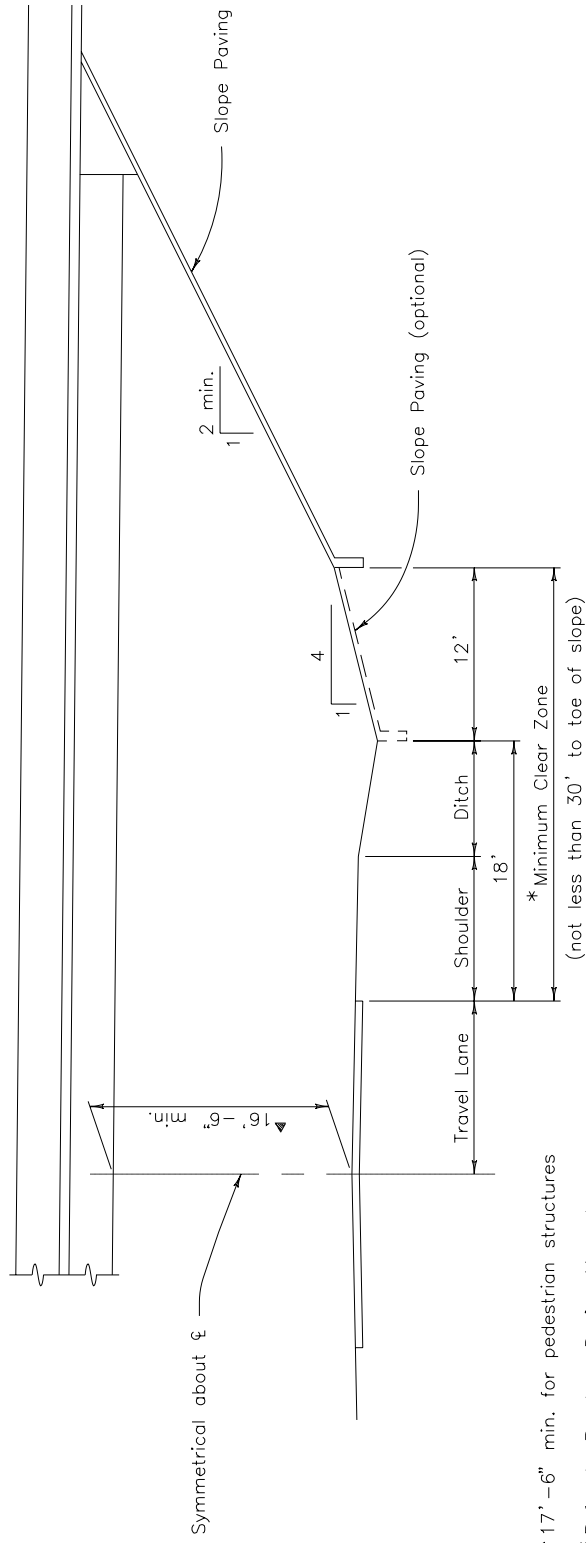

▲ 17'-6" min. for pedestrian structures  
\* Refer to Roadway Design Manual

LATERAL CLEARANCES — SINGLE SPAN BRIDGE

High speed and high volume undercrossings  
Two lane roadway (Design speed > 50 MPH & ADT > 750)

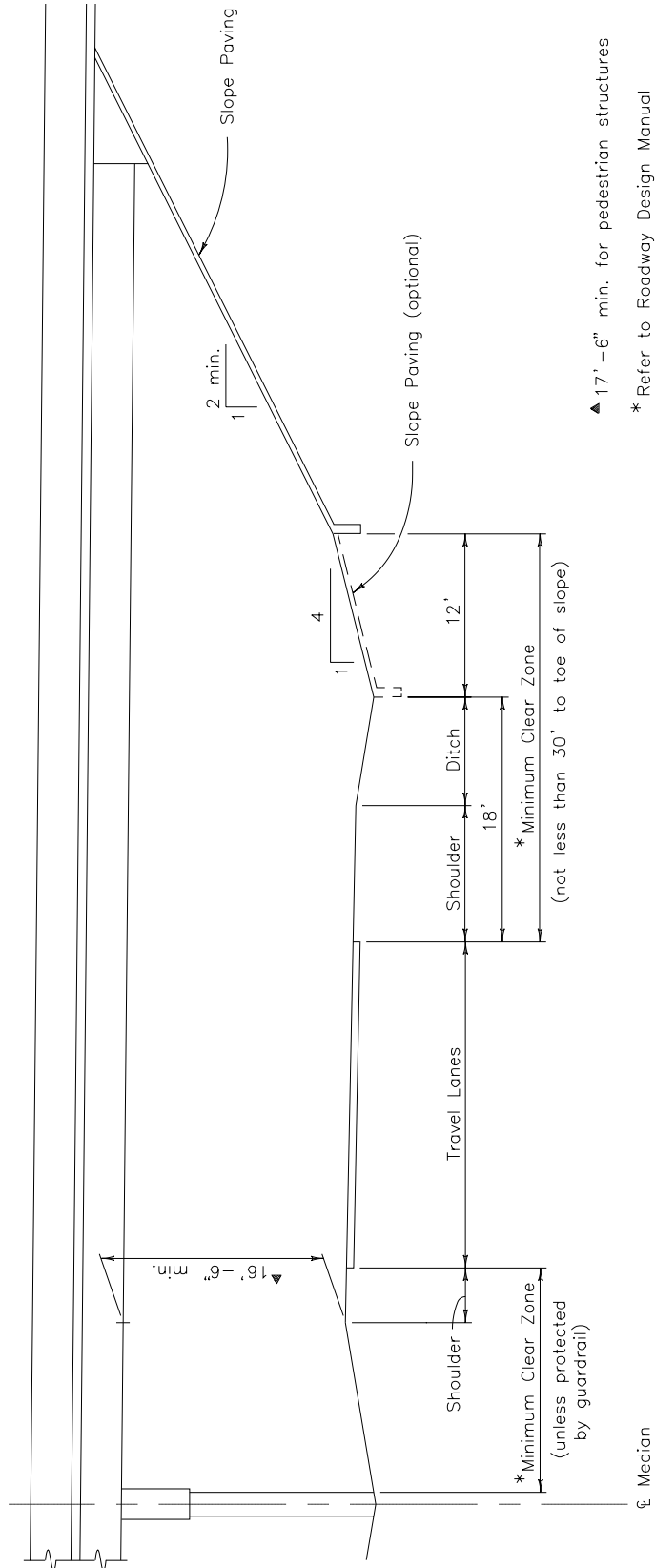

▲ 17' - 6" min. for pedestrian structures

\* Refer to Roadway Design Manual

LATERAL CLEARANCES - 2 SPAN BRIDGE (PREFERRED)

All Interstate undercrossings (urban and rural) and  
All other high speed divided highways (urban and rural)

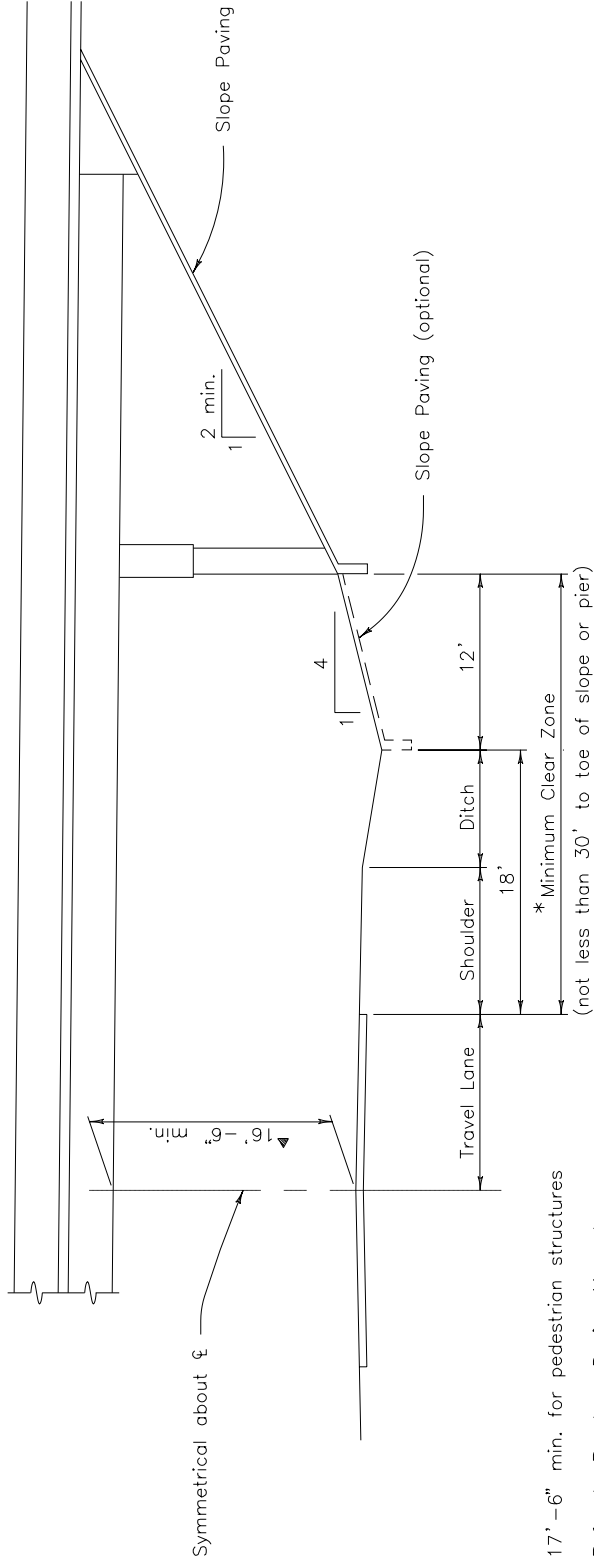

▲ 17' - 6" min. for pedestrian structures  
 \* Refer to Roadway Design Manual

LATERAL CLEARANCES - 3 SPAN BRIDGE (PREFERRED)

High speed and high volume undercrossings  
 Two lane roadway (Design speed > 50 MPH & ADT > 750)

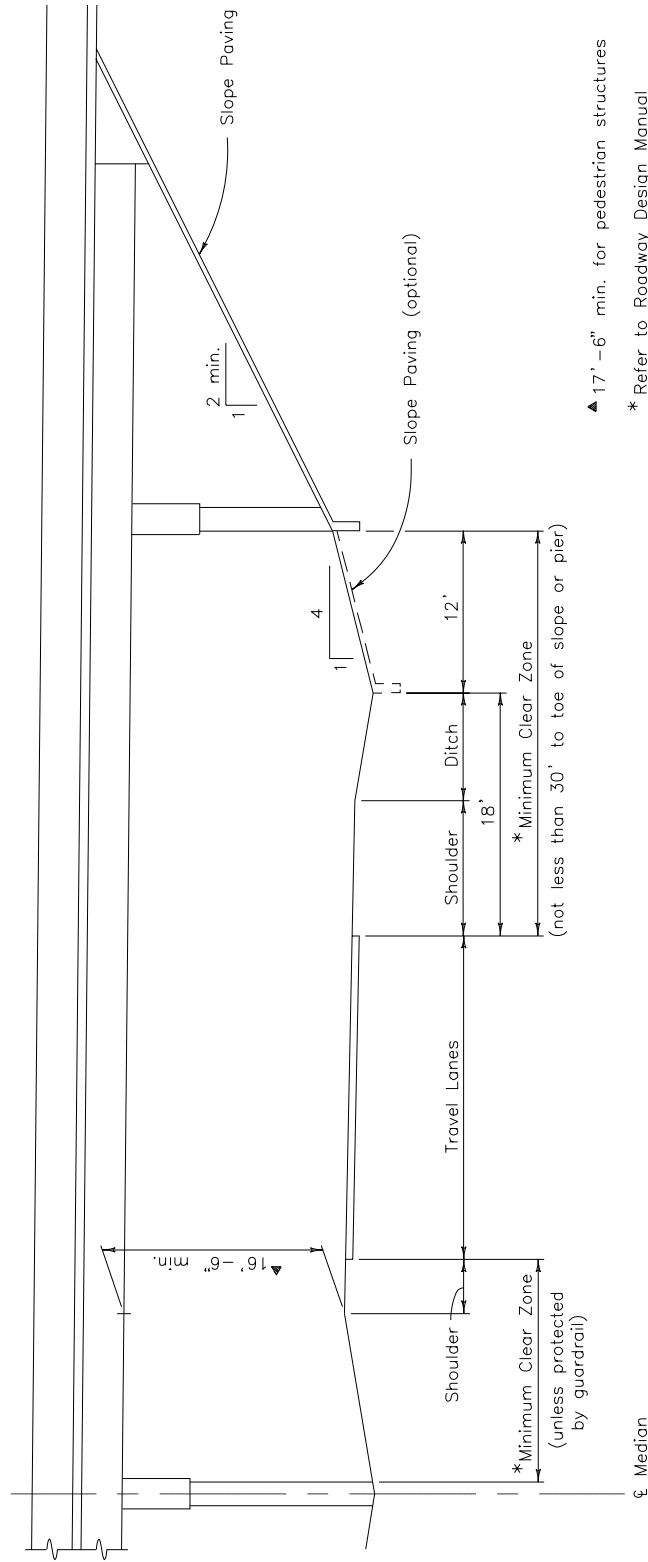

LATERAL CLEARANCES - 4 SPAN OR 5 SPAN BRIDGE

(For heavy skewed crossings and wide medians)  
All interstate undercrossings (urban and rural) and  
All other high speed divided highways (urban and rural)

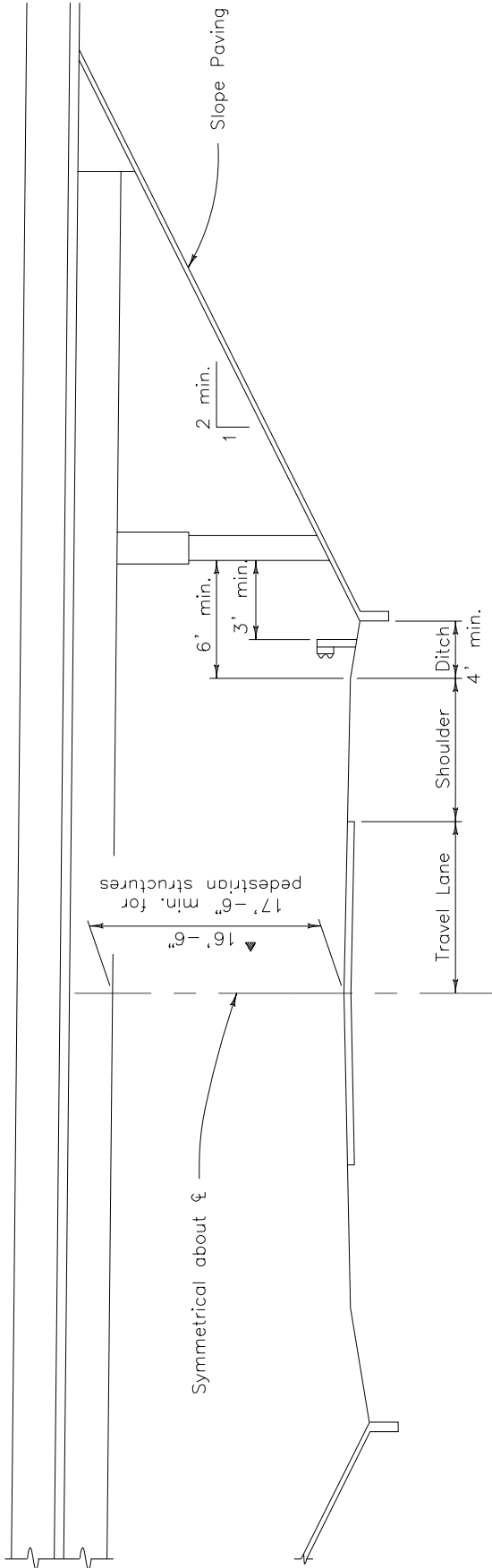

▲ This dimension may be reduced to 14' - 6" for certain local road or private entrance crossings.

### LATERAL CLEARANCES

Low speed and low volume undercrossings  
Two lane roadway (Design speed < 50 MPH & ADT < 750)



COLORADO DEPARTMENT OF TRANSPORTATION STAFF BRIDGE BRIDGE DESIGN MANUAL	Subsection: 2.4 Effective: August 1, 2002 Supersedes: March 20, 1989
RAILROAD CLEARANCES	

#### 2.4.1 REVISIONS

This revision allows the March 20, 1989 CDOT clearance requirements to lapse, and it synthesizes the clearance recommendations provided in the references that are cited in the next paragraph.

#### 2.4.2 REFERENCES

- Reference is to the Federal-Aid Policy Guide, Title 23-Code of Federal Regulations (23-CFR), Part 646, Subparts A and B as revised and published December 9, 1991, in the Federal Register, Vol. 53, and as amended on August 27, 1997 (metric units).
- Statutes and Rules Governing Public Utilities and Rules of Practice and Procedure before the Public Utilities Commission of the State of Colorado.
- Federal-Aid Highway Program Manual Volume 6, Chapter 6, Section 2, Subsection 1 with Attachment 1.
- AREMA 2000 Manual for Railway Engineering.
- AASHTO LRFD Bridge Design Specifications, 2<sup>nd</sup> Edition 1998 with 2000 Interim Revisions.

#### 2.4.3 GENERAL

All highway bridges over railroads shall meet the following requirements:

1. The minimum vertical clearance shall be 23'-0". This shall be defined by the C.L. of track at 90 degrees from the plane of top-of-rail (see figure 2) and be measured within the clearance envelope (see sheet 4 of 9). Clearances greater than 23'-0" may be approved on a project-by-project basis with special justification acceptable to both CDOT and the FHWA.
2. Attached at the end of subsection 2.4 is a six-page "For Information Only" table. In combination with this subsection, the For Information Only table replaces the (now lapsed) CDOT 1989 clearance requirements. The clearance minimums, which are typically required by railroad corporations are, listed alongside those recommended by railroad organizations, the Colorado Public Utilities Commission and the FHWA.
3. Greater clearances than those listed herein are required for tracks on a curve; see AREMA 2000, Chapter 28, subsection 1-1.
4. Bridge piers located within 25'-0" of the centerline of the outside track shall either meet the definition of being of heavy construction (see figure 1) or are to be protected by a reinforced concrete crash wall. See AREMA 2000 Chapter 8 subsection 2.1.5, the AREMA commentary C subsection 2.1.5 and AREMA figure C-2-1 for crash wall requirements.
  - A. Note to Designers and Project Engineers: Contractors have at times, been reluctant to build the reinforcing details that connect crash walls to columns. This usually arises from preferring not to drill holes through rented forms. Nevertheless, crash wall details shall be as necessary to satisfy applicable AREMA and AASHTO design requirements.

B. Criteria regarding vehicle and railway collision loads on structures found in AASHTO LRFD Bridge Design Specifications, Subsection 3, Loads; are also applicable to the design of crash walls, as appropriate.

C. Any crash wall design is to appropriately limit climbing accessibility and attractiveness to children, with regards to the child's safety.

5. Increased clearances for electrification must be validated by a formal plan for a logical, independent segment of the rail system, which must be approved by the railroad's corporate headquarters.

Per 23 CFR 646.212, the FHWA will participate in the following vertical clearances where electrification is planned:

For 25 kv lines, vertical clearance = 7.4 meters (24' - 3")

For 50 kv lines, vertical clearance = 8.0 meters (26' - 3")

6. A need for clearances greater than those shown or referenced herein must be documented by the railroad or justified by special site conditions.

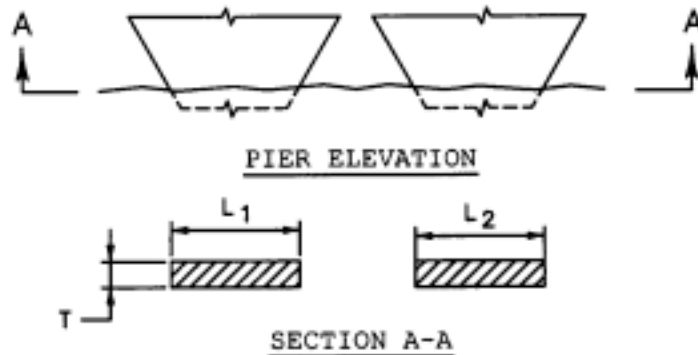

A pier is defined as being of heavy construction if:  
 $L_1 > 12'-0"$  and  $T > 2'-6"$  and the larger of its dimensions is parallel to the track.

**"HEAVY" CONSTRUCTION DETAIL  
 I.E. CRASH WALL NOT NECESSARY**

FIGURE 1



Topic	Railroad Corporation		Railroad Associations		CDOT	FHWA	FHWA	PUC	PUC
	BNRR 2000	UPRR 1998	AREMA 2000	AREA 1990	1989 Lapsed	1976	1991	1961	1988
<div style="display: flex; justify-content: space-between; align-items: center;"> <div style="border: 1px solid black; padding: 5px; width: 45%;"> <p><b>Vertical and Horizontal Clearance Envelope</b></p> <p>Dimensions of the following items, "A" through "F" are defined by the C.L. of track at 90 degrees from the plane of top-of-rail.</p> </div> <div style="text-align: center;"> </div> </div>									
<b>Vertical Envelope "A"</b>	<sup>i</sup> 23'-6" (Greater if a future flood is probable) <sup>ii</sup> Or 24'-0"	23' (Greater if a future flood is probable)	23' (7010.4 mm) (Greater if electrified)	23' (7.0104 m)	23'	23' (Greater if electrified)	23' (7.1 m) (Greater if electrified)	22'-6" min. (22' w/ telltales) Can go below 22' w/tell-tales & Commission approval	22'-6" min. (22' w/ telltales) Can go below 22' w/tell-tales & Commission approval
<b>Horizontal Envelope "B"</b>		8' - 6'	9' (2743.2 mm)	9' (2.7432 m)				8' - 6'	8' - 6'
<b>Horizontal Envelope "C"</b>		8' - 6'	6' (1828.8 mm)	6' (1.8288 m)				4'	4'
<b>Vertical Envelope "D"</b>	0'	0'	3' (914.4 mm)	3' (0.9144 m)				6' - 9'	6' - 9'
<b>Vertical Envelope "E"</b>	0'	0'	4' (1219.2 mm)	4' (1.2192 m)				4'	4'
<b>Horizontal Envelope "F"</b>	0'	0'	3' (914.4 mm)	3' (0.9144 m)				2' - 6'	2' - 6'

<i>Topic</i>	<i>Railroad Corporation</i>		<i>Railroad Associations</i>		<i>CDOT</i>	<i>FHWA</i>	<i>FHWA</i>	<i>PUC</i>	<i>PUC</i>
	<i>BNRR 2000</i>	<i>UPRR 1998</i>	<i>AREMA 2000</i>	<i>AREA 1990</i>	<i>1989 Lapsed</i>	<i>1976</i>	<i>1991</i>	<i>1961</i>	<i>1988</i>
<b><i>Criteria to Include a Future Track</i></b>	One or more future tracks as reqd. for operations	One or more future tracks as per long range planning, even along a low volume route		Adding future track where reasonably possible, depends on existing site			Fund a future track only after RR shows a demand and offers plans for its installation		It is reasonable to allow 1 future passing track at any mainline
<b><i>Track CL to Future Track CL</i></b>	25'	20'						15'	15'
<b><i>Maintenance Access Road (MAR) Width</i></b>		Offset to obstruction with MAR minus offset to obstruction w/out MAR is 7'		Add a MAR is reasonably possible, depending on existing site	Offset to ditch with MAR minus distance to ditch w/out MAR is 8'	8'	8' (0' if space for an 8" MAR is available in the adjacent span)		12' MAR or a 4' walkway on one side
<b><i>Offset to Slope from CL of Tracks @ the Plane of Top-of-Rail</i></b>		33' - 10'			20' assuming 2:1 abutment slope (28' if with MAR)	20' (22' if in cut)	20' (to be increased as indicated by drainage hydraulics or snow drifts)		

<i>Topic</i>	<i>Railroad Corporation</i>		<i>Railroad Associations</i>		<i>CDOT</i>	<i>FHWA</i>	<i>FHWA</i>	<i>PUC</i>	<i>PUC</i>
	<i>BNRR 2000</i>	<i>UPRR 1998</i>	<i>AREMA 2000</i>	<i>AREA 1990</i>	<i>1989 Lapsed</i>	<i>1976</i>	<i>1991</i>	<i>1961</i>	<i>1988</i>
<b><i>Height of Crash Wall (CW)</i></b>	6' Above Top-of-Rails where Pier is w/in 12' – 25' (CW not required if Pier is 25' or Greater from CL Track)	6' Above Top-of-Rails where Pier is w/in 12' – 25' (CW not required if Pier is 25' or Greater from CL Track)	6' Above Top-of-Rails where Pier is w/in 12' – 25' (CW not required if Pier is 25' or Greater from CL Track)	6' Above Top-of-Rails where Pier is w/in 12' – 25' (CW not required if Pier is 25' or Greater from CL Track)	6' Above Top-of-Rails where Pier is w/in 12' – 25' (CW not required if Pier is 25' or Greater from CL Track)				
<b><i>Height of CW if Pier w/in 12'</i></b>	12' Above the Top-of -Rails	12' Above the Top-of -Rails	12' Above the Top-of -Rails	12' Above the Top-of -Rails	6' Above the Top-of -Rails				
<b><i>CW Anchorage and Embedment in Ground</i></b>	Anchored to footings and columns, min. 4' below the (lowest) grade	Anchored to footings and columns, min. 4' below the (lowest) grade	Anchored to footings and columns, min. 4' below the (lowest) grade	Anchored to footings and columns, min. 4' below the (lowest) grade	Anchored to footings and columns, min. 4' below the (lowest) grade				
<b><i>Minimum CW Dimensions</i></b>	2' – 6" thick, 12' long and 1' past ends	2' – 6" thick, 12' long and 1' past ends	2' – 6" thick, 12' long and 1' past ends including a min. 6" cover over the track side of the column	2' – 6" thick, 12' long and 1' past ends	2' – 6" thick, for single column pier, 2'-0" thick for multi-columns, and 12' long including a min. 6" cover over the track side of the column				

<i>Topic</i>	<i>Railroad Corporation</i>		<i>Railroad Associations</i>		<i>CDOT</i>	<i>FHWA</i>	<i>FHWA</i>	<i>PUC</i>	<i>PUC</i>
	<i>BNRR 2000</i>	<i>UPRR 1998</i>	<i>AREMA 2000</i>	<i>AREA 1990</i>	<i>1989 Lapsed</i>	<i>1976</i>	<i>1991</i>	<i>1961</i>	<i>1988</i>
<i>Piers that are of "Heavy Construction" i.e. CW not necessary</i>	Are parallel to track w/cross section greater than that of crash wall	Are parallel to track w/cross section greater than that of crash wall	Are parallel to track w/cross section greater than that of crash wall	Are parallel to track w/cross section greater than that of crash wall					
<i>Minimum Offset to Obstruction (e.g. a pier) from CL of Tracks</i>	25' unless accompanied by a crashwall. The absolute minimum is indefinite (Piers are not to be located w/in drainage ditches)	Seemingly, 18' (25' where there is an access road between the track and an obstruction)		9' to nearest "obstruction"	9' to nearest "obstruction" (preferred that pier(s) be kept beyond toe of slope)	8' to nearest "obstruction"	9' to nearest "obstruction" (preferred that pier(s) be kept beyond ditch)	8' – 6" min. & 10' is recommended to the nearest "obstruction"	8' – 6" min. & 10' is recommended to the nearest "obstruction"
<i>Offset from CL of tracks to the Spread Footing</i>	Shoring must be a minimum of 15' from CL of nearest track. If excavation for shoring is intersected by a 1:1 line from the end of the tie; then a RR live load is applicable	No excavation allowed w/in 12' of the CL of track. Footing to be a min. 6'-0" below base of rail. Shoring and RR live loads per C.E. 106613			Determined by ½:1 slope but not less than 8' – 6"				

<i>Topic</i>	<i>Railroad Corporation</i>		<i>Railroad Associations</i>		<i>CDOT</i>	<i>FHWA</i>	<i>FHWA</i>	<i>PUC</i>	<i>PUC</i>
	<i>BNRR 2000</i>	<i>UPRR 1998</i>	<i>AREMA 2000</i>	<i>AREA 1990</i>	<i>1989 Lapsed</i>	<i>1976</i>	<i>1991</i>	<i>1961</i>	<i>1988</i>
<i>Drainage Ditch Depth; Below Plane of Top-of- Rail</i>		5.6' (6.4' if a v-shaped ditch)	3' to 4' The ditch profile may have to be steeper than the grade profile		3'	3'			
<i>Ditch Side Slopes</i>		2 H: 1 v (seemingly 1.57 H: 1 V)	Trapezoidal w/3' minimum bottom width; or V-shaped						
<i>Minimum CL Track to CL Ditch</i>		21'							



<i>Topic</i>	<i>Railroad Corporation</i>		<i>Railroad Associations</i>		<i>CDOT</i>	<i>FHWA</i>	<i>FHWA</i>	<i>PUC</i>	<i>PUC</i>
	<i>BNRR 2000</i>	<i>UPRR 1998</i>	<i>AREMA 2000</i>	<i>AREA 1990</i>	<i>1989 Lapsed</i>	<i>1976</i>	<i>1991</i>	<i>1961</i>	<i>1988</i>
<i>List of all pertinent regulations, decision, cases, standards, and recommended guidelines, i.e. of all pertinent railroad documents</i>	Burlington Northern Railroad Clearances for Highway and Pedestrian Overpasses (standard drawing) revised November 2000. Also, Guidelines for Design and Construction of Grade Separation Structures 2000.	Union Pacific Railroad Design Clearances (Standard Drawing 0035); General Shoring Requirements (C.E. 106613); Barriers, Fences and Splashboards (drawing UP-OH1); and Typical Sections at Abutment Slopes (Drawing UP-OH2); all dated 3/31/98. Also, a 7/10/97 conversation with UPRR's Kurt Anderson (concerning the horizontal envelope dimensions E and F); telephone (402) 271-5891	Recommended standards and practices as developed by the American Railway Engineering and Maintenance of Way Association's technical committees in order to assist railroad corporation(s) AREMA is a 1997 merger of the American Railway Engineering Association the American Railway Bridge and Building Association and the Roadmasters and Maintenance of Way	Recommended standards and practices as developed by the American Railway Engineering Association's technical committees in order to assist railroad corporation(s)	Bridge Design Manual Section 2.4 Standard Railroad Clearances	Federal Aid Highway Program Manual Transmittal 194; Volume 6 Chapter 6 Section 2 Subsection 1 Attachment 1	Reference is to the 23 Code of Federal Regulations (CFR) 646B	Reference is to Colorado P.U.C. Decision Nos. 38476 and 55621, Case No. 5032. Are minimum values of practice in the public interest? The P.U.C. has the authority to approve or disapprove individual projects and may determine sharing expense, up to 50% participation, by the railroad corporation, the state, county, municipality, local authority or etc.	Additional '88 references are to Colorado P.U.C. Case No. 6329-re-opened (1987) and Decision No. C88-374, April 6, 1988. The P.U.C. retains authority to approve or disapprove individual projects and may determine sharing expenses, up to 50% participation, by the railroad corporation, the state, county, municipality, local authority or etc.
<p>i Per BNRR Clearances for Highway and Pedestrian overpasses (standard drawing) dated 11/00</p> <p>ii Per BNRR Guidelines for Design and Construction of Grade Separation Structures, (2000).</p>									

PROTECTIVE SCREENING, SPLASHBOARDS, AND DRAINS OVER RAILROADS

---

All highway bridges over any railroad shall include the following:

Protective screening may be provided on both sides, full length of the bridge or 100 feet minimum from the centerline of the outside tracks.

Splashboards may be provided on both sides for the span over the tracks or for a minimum distance of 50'-0" from the centerline of the outside tracks. Splashboards shall be included in the cost of Fence Chain Link Special.

Bridge drains shall not be located within the length of the splashboard limits.

Bridge Rail Type 4 will be used for all bridges over railroads, unless the District requests the use of Bridge Rail Type 10.

See page 2 for more details.

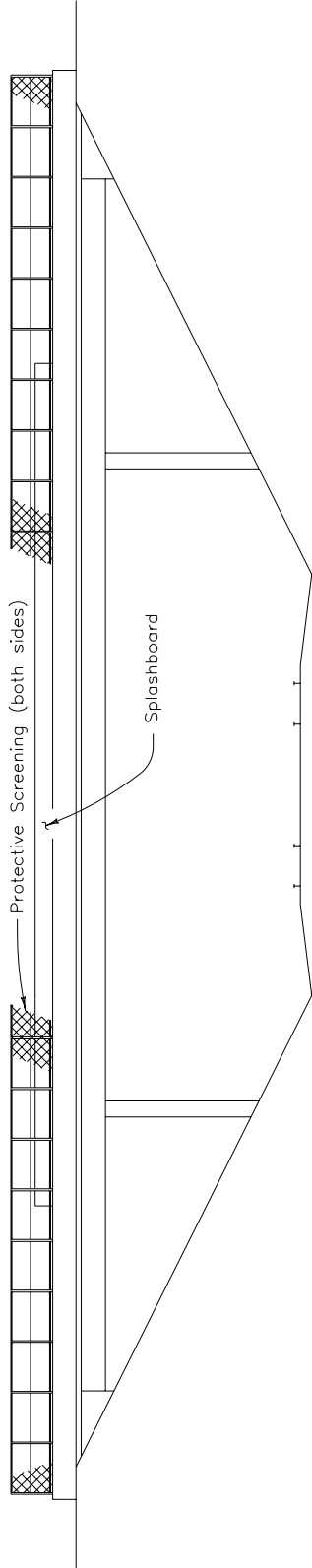

OVERPASS ELEVATION

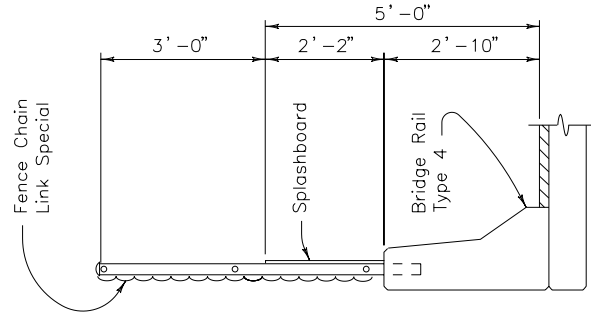

SECTION

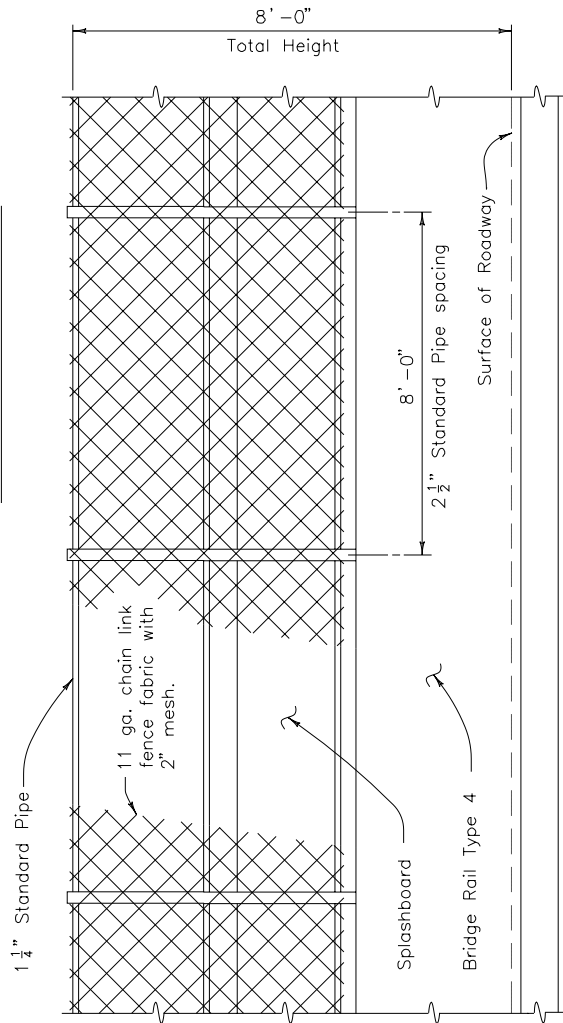

ELEVATION

SCREENED BARRIER FOR HIGHWAY OVERPASS

Drainage is to be diverted away from tracks and not discharged onto tracks and roadbed.

---

WIDTH OF ABUTMENT BERM

---

The width of the abutment berm, measured perpendicular to and in front of the front face of the abutment, shall be as indicated for the type of slope protection used:

For Concrete Slope Paving, the minimum berm width shall be two feet.

For Riprap, the minimum berm width shall be two feet plus the width of the riprap.

For 2:1 slopes, the riprap width shall be the square root of five multiplied times the riprap thickness.

See Subsection 7.2, Use of Integral Abutments, for additional information.

ACCESS FOR INSPECTION

POLICY

COMMENTARY

**GENERAL**

All bridge girders shall be made accessible either from the ground, from walkways installed within the girder bays, or by means of the "snooper" truck, as appropriate. All fracture critical details on bridges shall be made fully and readily accessible for inspection. The method of access used shall be both practical as well as the optimum method with all considerations taken into account. (C1)

**STEEL AND CONCRETE BOX GIRDERS**

Box girders with an inside depth of 5 feet or greater shall be made accessible for interior inspection. The bridge plans for these girders shall contain a note that all formwork (except steel stay-in-place deck forms and precast panel deck forms), concrete waste, and debris shall be removed from the inside of the boxes. (C2)

Steel box girders with an inside depth of less than 5 feet are discouraged. If used, they shall not be fracture critical members.

Access doors shall be aluminum, providing a 2' by 3' minimum opening, and shall open to the inside of the box girders. The doors shall be locked by a single padlock. Neither bolts nor screws may be substituted for the padlock. An example access door for steel box girders is shown on page 3 of this Subsection, and on Staff Bridge Worksheet B-618-2 for concrete box girders. (C3)

Traffic, required ladder heights or "snooper" reaches, and other obstacles shall be taken into account when locating access

C1: Parameters to determine which method should be used in a specific case are not available at this time. As a minimum, allowable ladder and snooper reaches should be provided by this memo in the future. At this time, designers must use their judgment in determining the optimum method of access to provide for.

C2: An inside depth limitation of 4', as well as 5', was initially considered. The 5' limitation was selected in order to insure that the access opening dimensions herein could be readily accommodated, and to provide the most reasonable space where entry by bridge inspectors would be required.

C3: There has been concern about corrosion between the aluminum door and the adjacent steel. With bare surfaces, this corrosion should be slow with aluminum as the sacrificial material. Therefore, problems are not anticipated within the probable life span of the structure. However, the plans should call for shop coating, as a minimum, of the aluminum to steel surfaces on painted girders. The designer may call for rubber shims at the interfaces with unpainted ASTM A588 steel if desired.

For payment, the aluminum plate should be included in the work for the girder. It should not receive a separate pay item. The plans should call for ASTM B209 aluminum plate, alloy number 6061-T6. Additional Material specifications are not needed.

May 1, 1992	Subsection No. 2.7	Page 2 of 3
POLICY		COMMENTARY

doors. Where possible, access doors near abutments should be placed 3 feet minimum to 5 feet maximum clear from top of ground to allow entry without a ladder. Where a ladder must be used above slope paving, support cleats or level areas for the ladder shall be provided in the slope paving.

Access through diaphragms within boxes shall be provided by openings 2'-6" or greater in diameter. At pier diaphragms, when special considerations may be necessary, the designer may submit to the Staff Bridge Engineer a request to use an opening between 2'-0" and 2'-6" in diameter.

The bottom of the opening through diaphragms within boxes shall not exceed 2'-6" from the bottom of the girder unless details for passing through higher openings are provided; for example, step platforms, or climbing handles up the side of the diaphragm and, if necessary, along the bottom of the deck. (C4)

Attachments to diaphragms (e.g. bearing stiffeners) and other possible projections shall be detailed so they will not present a hazard to someone passing through the box.

The 2'-6" minimum diameter opening shall be provided through steel box girder intermediate diaphragms by using k-type bracing, as shown to the right.

C4: Comprehensive standard details are not available at this time. Standard practice in providing access to box girders has not evolved to where specific details, other than the requirements given by this memo, are being mandated.

MISSING FIGURE

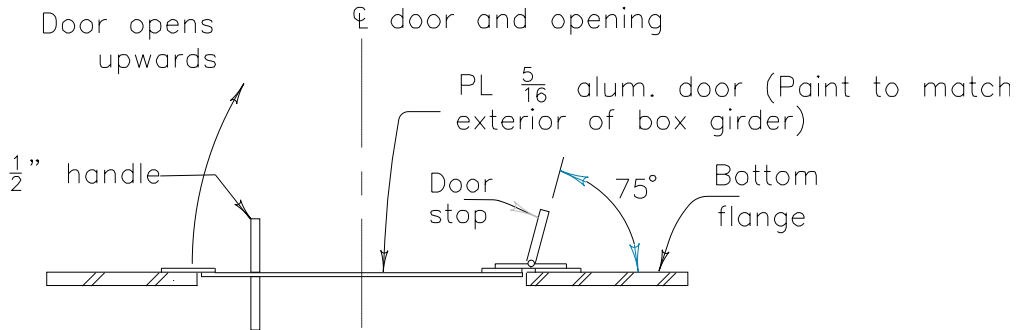
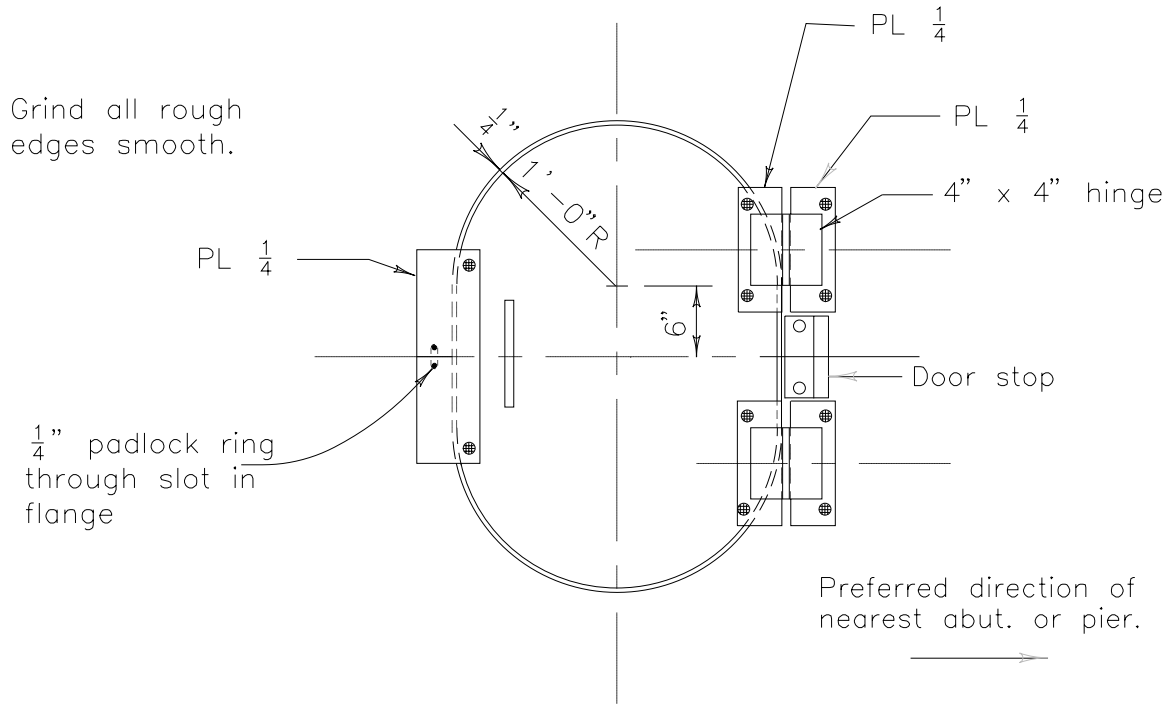

### ACCESS DOOR DETAIL

Door shall be aluminium ASTM B209 alloy no. 6061-T6. Other hardware and plates are ASTM A36 steel. Door and associated hardware to be included in Item 509 Structural Steel.

STRUCTURAL CAPACITY

POLICY

COMMENTARY

**GENERAL**

Allowable Stress Design (ASD) shall be used on all CDOT projects. Projects where steel and concrete are to be bid as alternates may be evaluated on an individual basis by the Staff Bridge Preconstruction Engineer for the possible use of Load Factor Design (LFD). Allowable Stress Design is recommended for off-system projects; however, Load Factor Design may be permitted if the local agency makes a formal request for its use. (C1)

The above policy applies where the AASHTO Standard Specifications provide the option of using either ASD or LFD. Where the option is not provided, the method required by the specifications shall be used. (C2)

For temporary loads with a probable one time application, LFD will be allowed. This will not apply to the seismic, wind, or 100 year stream condition loads on the completed structure. In addition, this will not apply to vehicle overloads. (C3)

Ultimate strength capacities, and plastic analysis, will be allowed for investigations made to identify non-redundant or fracture critical members. The members shall be sufficiently compact and braced to develop the final stress conditions assumed.

As a minimum, structures shall be designed to carry the load combinations specified in Article 3.22 of the AASHTO Standard Specifications.

C1: CDOT has historically used Allowable Stress Design. The current policy statement given here is taken from a April 30, 1986 memorandum from the Staff Bridge Engineer. With the ongoing development, and probable future acceptance, of the AASHTO Load and Resistance Factor Design Standard Specifications, Load Factor Design may eventually be phased in by CDOT. Until that time, Allowable Stress Design will continue to be used.

C2: The flexural strength checks for prestressed concrete design, and the design for negative moment over piers in prestressed precast girders made continuous, are examples of where Load Factor Design is to be used per the AASHTO specifications.

C3: Checking a pier for construction loads while the superstructure is being placed is an example of anticipated single occurrence loading where the use of Load Factor Design may be appropriate. Checking a pier for stability under the 500 year scour condition is another example.

C4: It is not possible for structural designers to anticipate all the loads that will occur during the fabrication, shipping, handling, and construction (as applicable) of structural members. However, as a minimum, completed members in their final location need to be designed for the loads they will probably receive under normal construction practices.

Generally, design engineers leave contractors free to select the methods of construction.



November 5, 1991	Subsection No. 3.1	Page 2 of 2
POLICY		COMMENTARY

**CONSTRUCTION**

Each member of a structure, once the member itself is complete and in place, shall have adequate elastic strength and stability to carry all anticipated construction loads that would occur during the remaining normal, or specified, construction phases. Members that cannot do this without falsework, except wet concrete members, shall be clearly identified in the contract documents. (C4)

**SEISMIC**

All structures shall be designed in accordance with the current AASHTO Standard Specifications for Seismic Design of Highway Bridges. (C5)

The allowable overstress (for Allowable Stress Design) and load factors (for load factor design) to use with the Seismic Performance Category A (SPC A) superstructure to substructure connection design force shall be consistent with the allowable overstress and load factor values given for SPC B.

**SUPERSTRUCTURE BUOYANCY**

For structures over waterways, provisions shall be made for the attachment of the superstructure to the substructure to prevent displacement of the superstructure due to hydraulic forces during flooding. Measures to allow entrapped air to escape, thereby decreasing buoyancy, should also be considered as necessary.

The contractor is then responsible for the integrity of the structure associated with the methods used. However, the design engineer needs to identify aspects of the structure that clearly require special considerations above and beyond typical construction practices.

Additionally, designers must make sure their structures are economical from a constructability standpoint. The means for providing adequate structural support during construction, and any uncertainties or risks contained in doing so, can be very expensive. If the support provided by the contractor has problems, the potential delays and legal claims are additional expenses to the project. It is counterproductive to carefully design the completed structure for economy while ignoring potential construction problems.

C5: As of the 1991 AASHTO Interims, all of Colorado is in Seismic Performance Category A (SPC A) with a maximum acceleration coefficient of 0.025. Designing the superstructure to substructure connections for a horizontal force equal to 20% of the dead load, and satisfying the minimum support lengths, are the only AASHTO design requirements for this category. Where the Category A superstructure to substructure design force appears too conservative, the Commentary to the AASHTO specification recommends using SPC B analysis and design procedures.

COLORADO DEPARTMENT OF TRANSPORTATION STAFF BRIDGE BRIDGE DESIGN MANUAL	Subsection: 3.2 Effective: November 1, 1999 Supersedes: May 1, 1992
COLORADO PERMIT VEHICLE	
POLICY	COMMENTARY

The axle weights and axle configuration shown below represent the Colorado Permit Vehicle. This vehicle is used to represent the maximum permit overloads allowed by CDOT on state highways. It is to be used for the AASHTO Group IB load case. It is a moving live load and is to be evaluated at the OPERATING level. The same live load distribution factors, or number of lanes loaded, and impact factors used with the HS-25 truck for checking the Group I load case shall be used with the Permit Vehicle for checking Group IB.

Deck slabs and other elements whose designs are governed by the HS-25 wheel load do not need to be checked for the Colorado Permit Vehicle.

The preferred method of assuring compliance with this provision is by providing an operating rating for the permit vehicle on the Bridge Rating Summary Sheet, see the *CDOT Bridge Rating Manual*.

To provide an indication of when this vehicle governs the design, a table is provided showing simple span moments and reactions for a vehicle 3/5 as heavy as this Permit Vehicle; for the HS-25 truck and lane loads; and for the military load.

In addition, rating values are shown for the HS live load (truck or lane load) equivalent to the Permit Vehicle at inventory and operating levels. The inventory value, based on load factor design criteria, is the HS live load equivalent to 3/5 of the Permit Vehicle. The operating value is the weight of the HS live load equivalent to the full Permit Vehicle. These equivalent rating values are the highest in the span for either moment or reaction, and considering the span either as

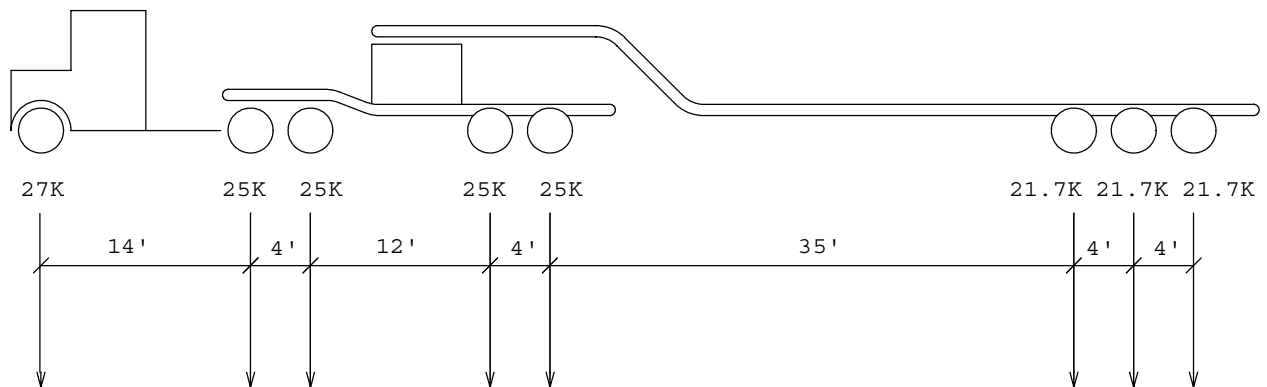

COLORADO PERMIT VEHICLE  
 192,000 LBS (96 Tons) on 8 Axles, 77 Feet Long

November 1, 1999	Subsection No. 3.2	Page 2 of 3
POLICY		COMMENTARY

For load factor designs, AASHTO 10.57.3.1, slip critical joints, may be either evaluated with 3/5 of an HS25 truck or by using the permit vehicle.

simple, or fixed-end with a hinge at the center, as shown below.



Considering the span as fixed-end with a hinge at the center is a conservative approximation of usual negative moment conditions. Typical span ratios do not provide stiffness that approach the fixed end condition. In addition, with typical span lengths, the single permit vehicle does not simultaneously load adjacent spans very effectively to produce maximum negative moment. Consequently, the permit vehicle will generally be less critical for negative moment than positive moment when checking a bridge that has been designed with the HS25 lane load.

The inventory HS rating values (HS-23 etc.) are appropriate for load factor design. They are conservative for working stress design if the operating allowable stresses are significantly higher than inventory allowable stresses (30% or so) and the live load to dead load ratios are 1.0 or lower.

Regarding the following table:

- Impact is not included.
- The values are subject to modification for loading of multiple lanes and appropriate distribution factors per the AASHTO specifications.
- The inventory rating value is the HS truck or lane load equivalent to 3/5 of the Permit Vehicle, in terms of HS.
- The operating rating value is the HS live load equivalent to the full permit vehicle, in tons.

TABLE OF MAXIMUM SIMPLE SPAN MOMENTS AND END SHEARS (ONE LANE)

SPAN (ft)	MAX. POSITIVE MOMENT (kip-feet)			END SHEAR (kips)			HS RATING				
	3/5	HS-25	INT.	3/5	HS-25	INT.	INV	OPR			
	PERMIT	TRUCK LANE	ALT.	PERMIT	TRUCK LANE	ALT.	(HS)	(tons) TRK LANE			
6	24	60*	37	36	20.0	40.0*	34.9	32.0	13	38	--
8	34	80*	51	54	22.5	40.0*	35.7	36.0	14	42	--
10	48	100*	66	77	24.0	40.0*	36.5	38.4	15	45	--
12	65	120*	82	100	26.0	40.0*	37.2	40.0	16	49	--
14	85	140*	99	123	27.9	40.0	38.1	41.1*	18	54	--
16	104	160*	116	147	29.3	45.0*	38.9	42.0	18	54	--
18	124	180*	134	171	30.4	48.9*	39.7	42.7	18	54	--
20	143	200*	152	194	31.2	52.0*	40.5	43.2	18	54	--
22	163	220*	172	218	32.7	54.5*	41.2	43.6	18	54	--
24	182	241	192	242*	35.0	56.6*	42.1	44.0	18	54	--
26	202	277*	214	266	36.9	58.5*	42.9	44.3	18	54	--
28	221	315*	236	290	38.6	60.0*	43.7	44.6	18	54	--
30	241	352*	259	314	40.0	62.0*	44.5	44.8	18	54	--
32	260	391*	282	338	41.3	63.7*	45.2	45.0	18	54	--
34	286	430*	307	361	42.4	65.2*	46.1	45.2	18	54	--
36	315	474*	332	385	44.2	66.6*	46.9	45.3	18	54	--
38	344	517*	359	408	45.9	67.9*	47.7	45.5	18	54	--
40	377	562*	385	432	47.4	69.0*	48.5	45.6	18	54	--
50	567	785*	531	552	53.2	73.1*	52.5	46.1	18	55	--
60	757	1009*	697	672	57.0	76.0*	56.5	46.4	19	57	--
70	948	1232*	884	792	59.8	78.0*	60.5	46.6	19	58	--
80	1138	1456*	1090	912	62.7	79.5*	64.5	46.8	20	59	--
90	1329	1686*	1316	1032	67.6	80.6*	68.5	46.9	21	63	--
100	1569	1905*	1562	1152	72.3	81.6*	72.5	47.0	22	66	--
110	1856	2130*	1929	1272	76.2	82.4*	76.5	47.1	23	69	--
120	2144	2354*	2115	1392	79.5	83.0*	80.5	47.2	24	72	--
130	2431	2579*	2421	1512	82.2	83.5	84.5*	47.3	25	74	--
140	2719	2804*	2747	1632	84.6	84.0	88.5*	47.3	25	76*	--
150	3006	3025	3094*	1752	86.7	84.4	92.5*	47.4	25	78	76*
160	3294	3250	3460*	1872	88.4	84.7	96.5*	47.4	25	80	75
170	3582	3405	3846*	1992	90.0	85.0	100.5*	47.4	25	82	73
180	3870	3700	4252*	2112	91.4	85.4	104.5*	47.5	24#	83	72
190	4158	3855	4679*	2232	92.7	85.6	108.5*	47.5	24#	84	70
200	4445	4150	5125*	2352	93.8	85.7	112.5*	47.5	23#	85	69
220	5021	4600	6078*	2592	95.8	86.1	120.5*	47.6	22#	87	66
240	5597	5050	7110*	2832	97.4	86.5	128.5*	47.6	21#	88	63
260	6173	5500	8222*	3072	98.8	86.7	136.5*	47.6	20#	89	60
280	6749	5950	9415*	3312	99.9	87.0	144.5*	47.7	19#	90	57
300	7325	6400	10687*	3552	101.0	87.3	152.5*	47.7	18#	91	55
330	8189	7075	12746*	3912	102.3	87.5	164.5*	47.7	17#	92	51
360	9054	7750	14985*	4272	103.3	87.6	176.5*	47.7	16#	92	48
400	10206	8650	18250*	4752	104.5	87.9	192.5	47.8	15#	93	44

# Indicates that points in the span with less than maximum moments or shears may have effects equivalent to or as high as HS-25.

\* Designates the controlling value for a span length for strength design.

COLORADO DEPARTMENT OF TRANSPORTATION STAFF BRIDGE BRIDGE DESIGN MANUAL	Subsection: 3.3 Effective: May 1, 2009 Supersedes: New
COLLISION LOAD (CT)	
POLICY	COMMENTARY

### 3.3.1 New Structures

Exposed supporting elements that can be hit by errant vehicles or trains shall be designed for the CT impact load.

Generally this will include pier columns, and non-redundant through type superstructure elements, such as thru trusses or thru arches. Due to the improbable coincidence of other loads, the analysis may be limited to the impact load and dead loads with a load factor of 1.0. (C1)

Concrete columns and compression members with a gross area greater than 2600 square inches with a minimum cross section thickness of 42 inches with minimum bonded well distributed flexural or column reinforcement in each exposed direction and with minimum stirrups or column tie transverse reinforcement need not be checked for CT loads. (C2)

Small members shall be checked for adequate load capacity. The minimum shear strength along the member shall be at least equal the applied shear from the CT load but not less than 160 kips. The shear strength need not exceed 400 kips at any point. Plastic analysis of the member may be used. (C3)

C1: While this does not happen often, collision from ships, trains and trucks is the second most common cause of bridge collapse.

C2: Concrete columns with an area greater than 2600 square inches meeting minimum longitudinal and transverse reinforcing requirements will normally have sufficient strength to resist the 400 kips collision load currently specified.

C3: Concrete columns and compression members with a cross section of less than about 450 square inches can not easily be designed to resist a 400 kips collision load. Larger concrete members with a cross section of less than about 1070 square inches may be capable of resisting a 400 kips collision load if the geometry is favorable (short members with fixity top and bottom) and they are heavily reinforced in flexure and shear. Concrete members with a larger cross section but less than 2600 square inches will normally need either a favorable geometry or greater than the minimum amounts of transverse and longitudinal reinforcing otherwise required.

The minimum shear capacity of 160 kips reflects shears that may occur very transiently due to inertial resistance of the column prior to plastic hinge formation. For example a pier restrained against translation and moment at the bottom, but unrestrained at the top would have a shear of 400 kips below the impact point and 0 kip above in a static analysis, but in the first instants of impact the inertia of the upper parts of the column and perhaps pier cap would provide lateral restraint above the impact point with an instantaneous distribution of the impact force closer to 240 kips below and 160 kips above the impact point.

Plastic analysis allows simple analysis by analyzing a non-redundant member with the moments at the top, bottom, and impact point set at the member flexural

May 1, 2009	Subsection No. 3.3	Page 2 of 5
POLICY		COMMENTARY

In unusual circumstances where members sufficiently strong to survive the impact load are impractical, the structure may be alternatively checked for adequate redundancy to resist collapse with the loss of the members that have inadequate strength to resist the impact load. This is done by analyzing the structure with the inadequate members missing with the structure subject to a load of at least 1.0 DL and 0.5 LL+I. Plastic analysis may be used. (C4)

For through type structures, such as thru trusses or thru arches, a 54 inch tall TL-5 barrier may be used to protect the through members.

### 3.3.2 Temporary Works

Temporary falsework towers that are within 30 feet of through traffic shall be able to resist a 400 kips impact load without collapse of the supported structure, or shall be protected by concrete barriers or rigid steel barriers with a minimum of 2 foot shoulder. The barriers shall have a minimum of 2 foot clear zone of intrusion from the tower to the traffic side top edge of the barrier. For speeds over 35 mph the barrier shall either be at least 54 inches tall or have 10 feet available for the zone of intrusion. If the speed is expected to be over 45 mph, or the ADTT exceeds 10,000 vehicles per day, or the through traffic is railroad or light rail traffic, then the barrier shall have the strength, stability and geometry required for a TL-5 barrier, except for cases where loss of the temporary tower would not cause collapse of the supported structure. (C5)

Guardrails protecting falsework towers or piers shall continue at full rail height for at least 30 feet each way from the tower and shall be configured with full height rigid barriers to prevent running around the rail end and hitting the tower from the opposite side of the rail. If ends transition into lower approach rails rather than crash cushions or barrels, that approach rail shall be a rigid rail type (such as Type 7) and shall not end for at least an additional 170 feet. (C6)

strength at those locations. Shears are found by the change in moments divided by distance between points.

Concrete filled steel tubes may be capable of resisting the 400 kips collision load with smaller sections than are required for concrete columns.

C4: A number of structures have survived the failure of columns, entire piers, or seemingly critical truss members without collapse. However, there is usually considerable difficulty to repair damage and the structure normally needs to be out of service for a considerable time for repairs, an issue for important structures. In addition, analysis of the alternate load paths can be difficult and lacks code guidance. Half the unfactored LRFD liveload approximates the liveload that can be expected within a slow response time up to a week.

C5: This controls the risk of collapse onto the interstate or railroad from collisions from errant vehicles. Falsework towers have been designed to resist collision loads in the past, although the typical reusable shoring is not capable of resisting collision loads of this magnitude. Eventually taller portable barrier schemes may be developed to protect these structures at low cost. Note that construction zones and lane shifts may increase the risk of errant trucks.

C6: This keeps any truck away from the temporary falsework and protects falsework towers from large debris from a head on impact between a vehicle and the end of the special barrier and prevents a vehicle mounting and straddling a barrier from reaching the tower or pier.

If the top of the barrier is smooth the length required to bring a high speed truck straddling the approach rail to a halt would be much longer. Type 3 barriers do not seem to slow straddling trucks much, but do lead the truck into the column. Methods for roughening the top of the approach rail should be considered.

May 1, 2009	Subsection No. 3.3	Page 3 of 5
POLICY		COMMENTARY

### 3.3.3 Existing Structures

When evaluating bridges for rehabilitation that may result in a potentially long remaining life, consider the risk of collapse or serious structural damage from future collision loads. If that risk is high consider adding mitigating measures such as strengthening columns or at risk members or improving approach rails protecting at risk members. (C7)

Placing a barrier in front of a pier or other obstacle should not in itself be considered as providing adequate protection. The barrier heights, offset distances, and transition guardrail treatments given in Subsection 3.3.2, the AASHTO specifications, and AASHTO Roadside Design Guide must be considered when evaluating risk of collapse or serious structural damage. Barrier height and offset distance should be optimized to help prevent high center of gravity vehicles from leaning over the barrier and into the pier or obstacle. Transition guardrail details should be optimized to help prevent vehicles from riding up on top of the barrier, or getting behind the barrier, and traveling into the pier or obstacle. (C8)

C7: It may be relatively economical and practical to strengthen a structure by adding or strengthening members, or providing or upgrading protection to prevent impacts if this work is concurrent with other widening or rehabilitation.

There is a Texas research project Funded, Contract/Grant Number: 9-4973, but not underway at this time on the issue of the CT load.

There is additional discussion and guidelines under development on this topic by CDOT Staff Bridge Branch.

C8: In addition to vehicles riding up on top of barriers, high center of gravity vehicles lean over the top of barriers. See the discussion in the *AASHTO Roadside Design Guide, 3<sup>rd</sup> edition, 2006, article 6.4.1.8, Concrete Barrier.*

The CDOT and other DOT's place barrier around pier walls and columns to protect them from traffic impacts, but the presence of the railing does not guarantee that the substructure elements won't be damaged. In the last couple of years there have been several examples of these impacts on Colorado's highways:

Structure H-02-EM, which carries County Road 26.5 over I-70 in Grand Junction, was impacted by a tanker truck in August of 2007. From the Type 3 transition guardrail the truck rode up on top of the concrete barrier and into the pier taking out one of the two pier columns. See photos 3.3-1 & 3.3-2.

Structure L-18-BA, which carries S.H. 45 over I-25 south of Pueblo, was impacted by a tractor-trailer in December of 2005 where the median barrier actually launched the truck into the outside pier column. See photos 3.3-3 & 3.3-4.

Structure F-19-AH, which carries a ramp to S.H. 36 over I-70 near Strasburg, was impacted by a tractor-trailer in March of 2008. In this case, the truck went off the road behind the railing to take out the exterior column. See photo 3.3-5.



Photo 3.3-1



Photo 3.3-3



Photo 3.3-2



Photo 3.3-4





Photo 3.3-5

---

PILING

---

**GENERAL**

1. All projects with piling shall require a minimum 26,000 ft-lb hammer; therefore, no piling should be used with a section area less than an HP 12 X 53.
2. Alternate piling no longer needs to be identified under the summary of quantities, unless the Geology Report recommends pipe piling as an alternate.
3. Pile type and tip elevations will be given in the Geology Report, and should be shown on the plans with a minimum tip elevation. This minimum tip elevation is normally 10 feet above the estimated tip elevation, unless the designer feels there is unusual geologic circumstances that warrant a recommendation from Geology. The designer should select the size of pile based on actual loads. Generally, maximum economy is achieved by using the largest size piles acceptable in keeping with a reasonable pile spacing and pile footing configuration. It is preferable to have one pile size per project.
4. If the Geology Report indicates that pre-drilling may be required, this requirement shall be discussed with the geologists to determine the reason for the uncertainty. If the requirements remain valid after a structural evaluation by the designer, a pay item should be included on the plans for pre-drilling all piling involved, as though pre-drilling is required.

**SPACING**

1. Spacing and clearances shall be as per AASHTO except as amended herein.
2. A 6" minimum clear edge distance may be used in special cases where a channel or some other structural element or method is used to align the piles.
3. Pipe piles shall be spaced no closer than 3'-0".
4. For footings only, use a 1'-6" minimum clear edge distance when a group of 5 or fewer piles is used.



---

CAISSON DESIGN

---

The capacity of the soil to support vertical loads from caissons shall be based on end bearing and/or side shear, depending on the type of geological materials in which the caisson is embedded. The plans shall indicate the values of end bearing and side shear used in design.

The use of shear rings or a roughened hole surface shall not be used as a means of increasing the design value of side shear unless the engineer can justify their use. When shear rings or roughened holes are needed the engineer shall request allowable design values for smooth holes, holes with shear rings and roughened holes. The geotechnical engineer shall be requested to dimension the size and spacing of shear rings, these dimensions shall be shown on the plans. Hole roughening methods shall be as stated in the project special provisions.

When shear rings are specified they must be inspected to positively determine the condition of the hole surface. The special provisions shall include defining the inspection method to verify the condition of the holes. No special methods will be necessary when a roughened hole surface is used but the method of roughening must be specified.

EARTH RETAINING WALL DESIGN REQUIREMENTS

---

**5.1.1 GENERAL REQUIREMENTS FOR ALL WALL TYPES**

*5.1.1.A GENERAL*

Retaining walls shall be designed for a service life based on consideration of potential long-term effects of corrosion, seepage, stray currents and other potentially deleterious environmental factors on each of the material components comprising the wall. For most application, permanent retaining walls should be designed to resist corrosion or deterioration for a minimum service life of 75 to 100 years.

*5.1.1.B WALL TYPES AND SELECTION STUDY REPORT*

All wall types as classified in Subsection 5.3 and approved proprietary wall systems as listed in the CDOT pre-approval wall list developed through the process as described in Subsection 5.2 shall be fully considered and used for a retaining wall project.

To insure all feasible wall systems are included and generate best decisions, the wall type selection process as shown in the Subsection 5.4 shall be followed. The selection process shall be documented and the work sheets, as shown on Subsection 5.5, shall be used as evidence to support the decision.

The Wall Selection Study Report shall be a stand-alone report with a cover letter and a site plan which clearly indicates the names and locations of the walls.

*5.1.1.C WALL DEFAULT DESIGN AND DESIGN ALTERNATIVE(S)*

The designer should come up with a default detailed design along with the design alternative(s) if applicable. The requirements for assigning alternate wall are described in Subsection 5.8. The default design is defined to mean the best wall obtained from the selection process. For earth retaining wall project, regardless of the type of wall actually constructed (default or alternate), the measurement and payment are based on the plans of default design as specified in Subsection 5.6. Design alternatives are the products of the selection process described in Subsections 5.4 and 5.5. The design alternatives furnished in the bidding documents shall be at the level of conceptual designs and in the form of typical profiles with dimensions. Using Subsection 5.7 as guides, the designer shall specify the requirements of the Contractor or supplier prepared designs and plans for the design alternative(s).

*5.1.1.D OBJECTIVES AND CONSTRAINTS OF RETAINING WALL DESIGN PROJECT*

For all earth retaining wall design projects the objective and constraints should be properly defined. These include, but are not limited to, wall geometry, such as: 1. Tolerance on finished product; such as vertical and horizontal position of the wall top line. 2. Allowable long-term wall settlement.

Different allowable long-term wall settlements along the alignment of the wall may be specified to facilitate a smooth transition on top of wall elevation between wall on deep foundation at one end and spread footing at other end.

#### *5.1.1.E GEOLOGY REPORTS AND REQUEST OF ADDITIONAL BORING LOGS*

For earth retaining wall projects a request for a preliminary geology report should be done right after the completion of roadway design. Without the exact locations of bridge piers and abutments a default boring log spacing may be

specified to speed up the process and provide valuable information. Wall selection should be based on the preliminary geology report. During the selection process if additional boring log information is needed and requested by the designer an intermediate report should be provided to the designer. The final geology report shall comment on the foundation(s) related to the selected wall type(s) and if applicable give the related design parameters such as properties of on-site fill material for a cut/fill scenario and properties of anchored zone for a tieback case.

#### *5.1.1.F WALL DESIGN BASED ON PLANE STRAIN CONDITION*

All walls can be designed with a unit width (except that the plane strain condition is no longer valid, when conditions exist such as wall alignment across a ravine, founded on sloped compressible layer, has a non-uniform seepage force, flood plain erosion is anticipated, etc.). In case of doubt a cross-section of the soil strata along wall alignment plus soil strata section(s) across wall alignment are needed, for serious landsliding potential and a three dimensional study may be needed to determine the pattern of fill movement and the corresponding deformation of the wall. Designer must bear this in mind.

#### *5.1.1.G BRIDGE ABUTMENT WALL*

The permissible level of differential settlement at abutment structures must be considered to preclude damage to superstructure units. The following data developed by Molten (FHWA TS-85-228) shall be used as the upper bound of serviceability criteria for abutment wall design.

For span lengths of less than 50, feet differential settlement up to 2 inches between supporting members can be tolerable with maximum negative stress increases in continuous beams on the order of 10 percent.

For span lengths in excess of 100 feet, limiting angular distortions to .005 of span length for simple span bridges and 0.004 of span length for continuous bridges would generally yield increases of maximum negative stress on the order of 5 percent.

For span lengths in the 50 to 100 feet range, differential settlement should be limited to three inches between supporting members to insure that maximum negative stress or stress increases in continuous beams is kept below 10 percent range.

#### 5.1.1.H QUALITY ASSURANCE OF WALL DESIGN AND CONSTRUCTION

A quality assurance plan is the vital center of earth retaining wall project. The plans and specifications shall outline the necessities of quality assurance in design as well as in construction.

#### 5.1.2 CONCRETE CANTILEVER RETAINING WALL

##### 5.1.2.A TOP OF WALL

For a retaining wall without a curb or concrete barrier attached, the top of the wall shall be a minimum of one foot above the ground at the back face.

##### 5.1.2.B FOOTING SLOPED OR STEPPED

Sloped footings are preferred with maximum slope of 10 percent.

Stepped footings may be used with a maximum step of 4 feet.

##### 5.1.2.C FOOTING PRESSURE

For retaining walls under 10 feet in height, or bearing pressures of 1 ton per sq. ft. or less, the designer shall determine if an Engineering Geology Report is needed.

For design height greater than 10 feet, the bearing pressure shall not exceed the allowable pressure as determined by an engineering geology report.

##### 5.1.2.D FOOTING-COVERS

The top of the footing shall have a minimum cover of 1'-6".

The bottom of the footing shall be a minimum of 3 feet below finished grade.

##### 5.1.2.E GUTTER

If the area behind the retaining wall is relatively large and a substantial amount of run-off is anticipated, a concrete gutter is required behind the wall in addition to the drainage required by AASHTO.

##### 5.1.2.F EQUIVALENT FLUID WEIGHT

The requirements and recommendations of applying lateral earth pressure are given in Subsection 5.9.

#### 5.1.3 EARTH WALL (M S E WALLS AND SOIL NAILING WALLS)

### 5.1.3.A CONSTRUCTION AND ERECTION

Construction and erection shall be as per approved construction drawings and shop drawings. If a proprietary product is used, a company representative shall be present at the project site to assist the Fabricator, Contractor and Engineer until all involved parties are familiar and confident in their functions.

### 5.1.3.B WALL FACING

For a retaining wall supporting roadways without a curb or concrete barrier attached to the top of wall, there should be a maximum of 4 to 1 slope and 3' minimum horizontal distance from back of facing to any load carrying member such as rail posts, high mast lights, edge of slab and etc. Run-off shall not be permitted to pass freely over the wall surface; rather, a wall coping, drain system, or a properly designed roadway ditch shall be used to carry run-off water along the wall and to be properly deposited.

For a retaining wall with a curb and concrete barrier attached to the top of facing there should be a minimum 8' wide (including rail), 20' long monolithically constructed reinforced concrete barrier and slab system to carry and spread loads.

A minimum 12" wide, properly attached geo-textile fabric either per vertical or horizontal joint at backside is required to protect fines from washing away.

### 5.1.3.C IMPERVIOUS MEMBRANE

For a retaining wall with reinforcement subject to corrosion (e.g., a metal reinforced MSE wall supporting a roadway which is de-iced with chemicals), an impervious membrane should be placed above the reinforced zone and sloped towards properly designed collector drains. The membrane shall have enough coverage area to intercept all de-icing agents. The impervious membrane shall be high density polyethylene, 30 mil in thickness, formulated with a minimum of 2% by weight of finely ground carbon black, 20 feet minimum roll width and conforming to the following additional requirements:

Dimensional Stability - ASTM D-1024 : + or -2 percent  
Tear Resistance - ASTM D-1004C: 22 lbs. min.  
Resistance Soil Burial - ASTM D-3083 : 90 percent Retained Strength

### 5.1.3.D DRAINAGE BLANKET

For a retaining wall supporting roadways in side hill cuts, geometric involving ground and seepage water, and fills with marginal quality, a drainage blanket should be constructed at the back of reinforced zone to intercept water.

For a retaining wall using cohesive fills a properly designed drainage system with a 2' minimum thick geo-textile bounded drainage blanket at the back of reinforced zone should be used.



*5.1.3.E FILL MATERIAL OF METALLIC REINFORCED ZONE*

Fill material shall meet the following requirements when tested with laboratory sieves:

Sieve Size	Percent Passing
3 Inches	100
3/4 Inches	20-100
No. 40	0-60
No. 200	0-5

Metallurgical slag or cinders shall not be used except as specifically allowed by the designer. Furnish material exhibits an angle of internal friction of 34 degrees or more, as determined by AASHTO-T-236, on the portion finer than the number 10 sieve. The backfill material shall be compacted to 95% of AASHTO T-99, method C or D at optimum moisture content.

Provide material meeting the following electrochemical criteria:

Criterion	TEST Method
Resistivity > 3,000 Ohm-centimeter	Cal. DOT 643
Chlorides < 50 parts per million	Cal. DOT 422
Sulfates < 100 parts per million	Cal. DOT 417
PH 6-10	Cal. DOT 643

On-site or local material of marginal quality can only be used on the default wall design with the discretion and assignment of the designer.

*5.1.3.F CORROSION PROTECTION OF CARBON STEEL REINFORCEMENTS*

Corrosion resulting from the use of de-icing salts in winter time, ph value of ground water, and chemical composition of fill material shall be considered in the design to ensure a design to meet design life. For a design which meets the requirements of this Subsection the following corrosion rates will apply.

For zinc: 15 um/year (first two years).  
4 um/year (thereafter).

For carbon steel after zinc loss:  
12 um/year

If fusion bounded epoxy coating is used on hardware and/or reinforcements, the minimum thickness shall be 18 mil.

*5.1.3.G LIMITATIONS ON SOIL NAILING WALL*

This type of wall shall not be used except on an experimental feature subject to prior approval by Staff Bridge.

*5.1.3.H DURABILITY OF POLYMERIC REINFORCEMENTS*

In the absence of reliable information regarding the quality control of the construction process, the allowable strength of the geo-synthetic should be decreased by 50 percent to account for site damage. Facings shall be used for protection from ultraviolet (UV) effect and possible vandalism. A minimum of 4.5 inches of an articulate precast reinforced concrete facing system or 6" x 6" treated timber structural solid facing is required.

*5.1.3.I FILL MATERIAL OF POLYMERIC REINFORCED ZONE*

1. Fill material shall meet the following requirements when tested with laboratory sieves:

Sieve Size	Percent Passing
3 Inches	100
No. 40	0-60
No.200	0-15

2. Plasticity Index (PI) shall not exceed 6 or internal friction shall be 25 degrees or more as determined by AASHTO-T-236.
3. Soundness; the material shall be substantially free of shale or other soft poor durability particles. The material shall have a magnesium sulfate soundness loss (or an equivalent sodium sulfate value) of less than 30 percent after four cycles.
4. Pea gravel shall be used to fill between the facing to the 1 to 1 sloped selected fill at each lift unless other provisions are made and approved by the designer to ensure the quality of compaction adjacent to facings.
5. The percent of relative compaction shall be equal to or greater than 95 percent as per T 99, or 90 percent as per T 180 of AASHTO.

On-site cohesive, or local, granular material with sharp edges having marginal quality can only be used on the default wall design with the discretion and assignment of the designer.

*5.1.3.J QUALITY ASSURANCE OF CONSTRUCTION*

1. The material supplier shall furnish material in compliance with the specifications and with copies of all test results attached.
2. During construction the CDOT shall have a plan for sampling and material testing to ensure that the material meets the specifications in the contract document.

CDOT PROCEDURES OF PROPRIETARY WALL APPROVAL

The recent growth of proprietary earth retaining systems provides many cost effective designs. Prior to being adopted and listed as feasible alternate wall systems in CDOT planning and contract documents, all proprietary products must go through the departmental approval process. The criteria for selection and placement on the approval list are as follows:

- A. A supplier or his representative must request in writing that the proprietary wall or wall system be placed on the CDOT pre-approved alternate systems. All new systems shall go through the Department's Product Evaluation Procedure (DPEP) and be approved prior to use on Department projects. The request of application form of product evaluation (Form No. 595) and all correspondences shall address to

Product Evaluation Coordinator,  
Department of Transportation,  
Staff Material Branch,  
4340 East Louisiana,  
Denver, CO 80222

Phone No. (303)757-9269

The Product Evaluation Submit Package shall contain the followings:

- \* A cover letter,
  - \* DOT Form 595,
  - \* Wall Record(s) (Page 5 of 5 of this Subsection)
  - \* Supporting documents (10 items described in this Subsection).
- B. The Department will evaluate and approve the system, based on the following considerations.
- \* The system has a sound theoretical basis so that the Department can evaluate its claimed performance.
  - \* Past experience in construction and performance of proposed system, or the supplier can convince the Department of the soundness of the product by the findings of an experimental study.
  - \* A letter from a P.E. registered in Colorado certifying the product.

For this purpose, the supplier or his representative must submit a package which satisfactorily presents the following items:

1. Complete design procedure and calculations.
2. System theory and the year it was proposed.
3. Laboratory and field experiments, if applicable, including instrumentation and monitoring data which support the theory of product design.

4. Applications with descriptions, including length, height, location and photos, and a list of users including names, location, and phone numbers if available.
5. A sample of the analysis and design of wall elements with different back slope geometries (as in Exhibit 1), if applicable the design of wall attachments (Exhibit 2), all design calculations and assumptions, minimum factors of safety, estimated life, corrosion protection design for soil reinforcement elements that conforms to the latest AASHTO and related ASTM standards.
6. Design aids, design manual, design charts, or computer software may be included if applicable.
7. Sample material and construction control specifications showing material type, quality, certifications, field testing, acceptance and rejection criteria and placement procedures.
8. A well documented field construction manual describing in detail, and with illustrations where necessary, the step by step construction sequence. A copy of this manual should also be provided to the contractor and the project engineer at the beginning of wall construction.
9. Typical unit costs, supported by data from actual projects if applicable.
10. Limitations of the system, data provided must show allowable settlement, maximum toe pressure, equivalent strength parameters of backfills, precautions required during excavation and construction, as well as the possibility of internal and external failure mode.

It is the supplier's option to submit preliminary design criteria to CDOT before the development of a formal submittal for DPEP. This submittal will be given a thorough review by the Department with regard to the design, constructibility and anticipated performance of the system.

In the submittal package, a cover letter and the record information (format as shown on Exhibit 3) for each wall type submitted are required. The Department's position on the submission, i.e. acceptance, pending further information, or rejection, with technical comments will be provided by a written notification from CDOT.

Even though a system has been pre-approved, the Department retains the right to decide whether a particular system is appropriate for a given site or location. The list of the pre-approved walls will be revised periodically and the most updated list will supersede the previous one.

NOTE: The dashed line shows imaginary back of wall, and soil pressure boundary.

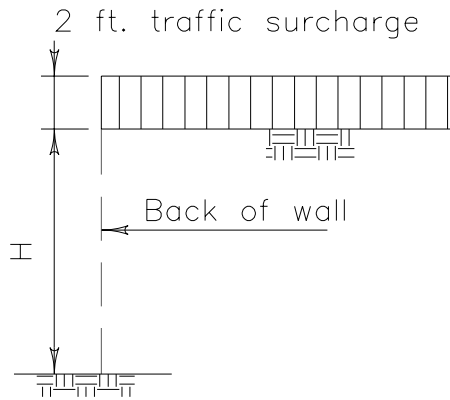

CASE 1

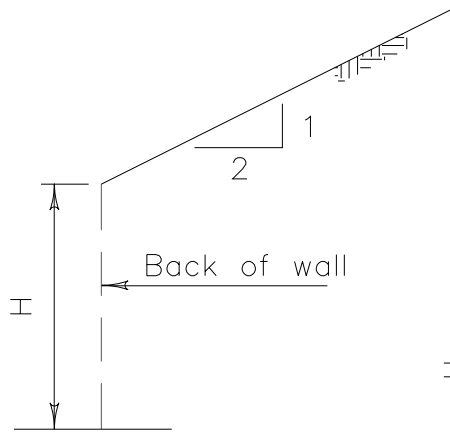

CASE 2

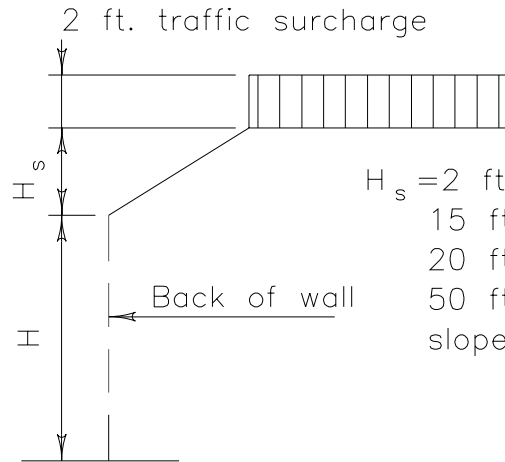

$H_s = 2 \text{ ft}, 5 \text{ ft}, 10 \text{ ft},$   
 $15 \text{ ft, if applicable}$   
 $20 \text{ ft}, 30 \text{ ft}, 40 \text{ ft},$   
 $50 \text{ ft and unlimited}$   
 $\text{slope.}$

CASE 3

EXHIBIT 1 WALL BACK SLOPE GEOMETRY

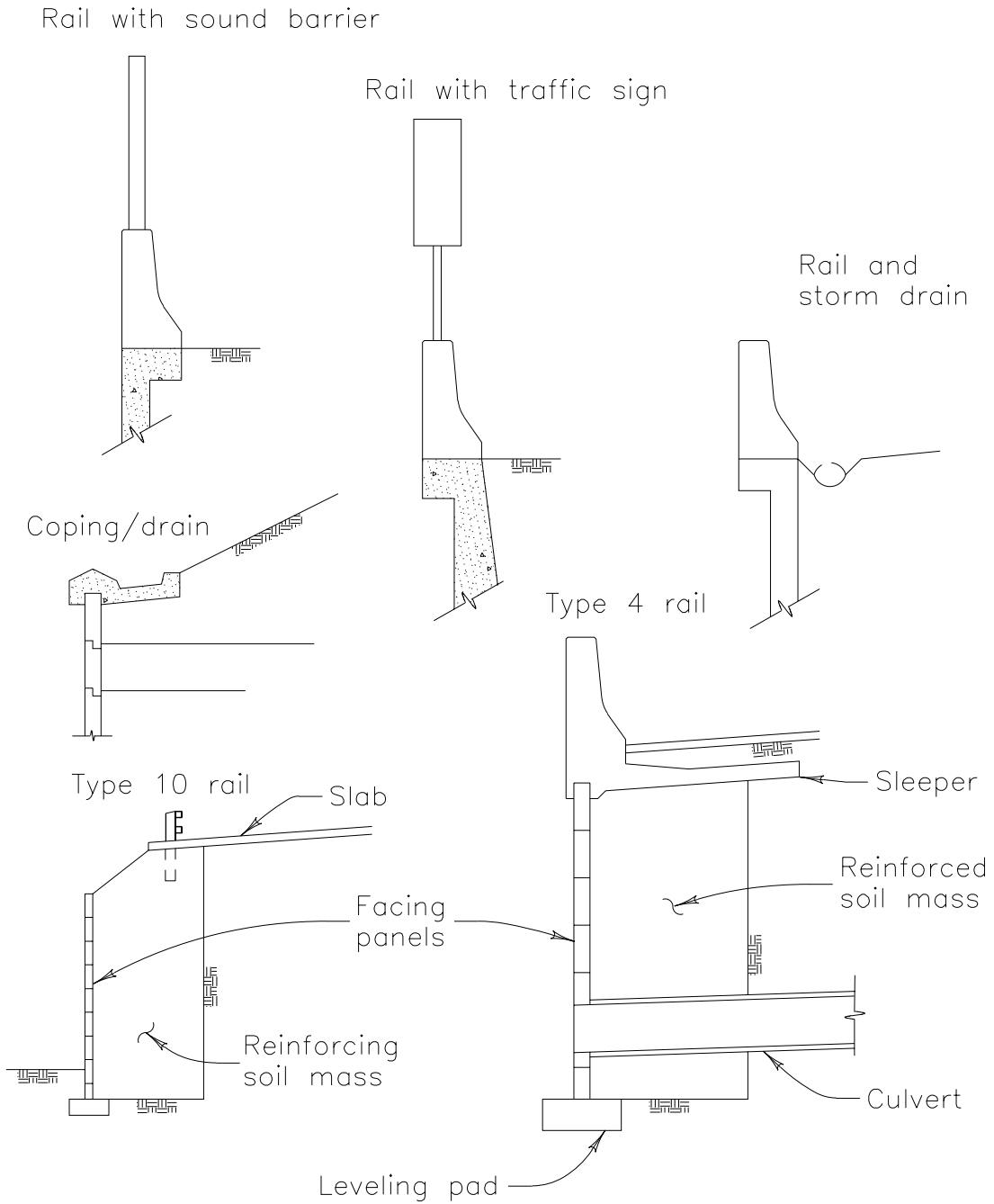

EXHIBIT 2 WALL ATTACHMENTS

WALL NAME<sup>(TM)</sup>: \_\_\_\_\_

PATENT INFORMATION (no. and duration of validity): \_\_\_\_\_

RANGE OF WALL HEIGHT: \_\_\_\_\_

WALL SCENARIO (if applicable):

\* TYPE AND CONDITION OF STRUCTURAL BACKFILL MATERIAL: \_\_\_\_\_

\* TYPE AND CONDITION OF RETAINED FILL: \_\_\_\_\_

\* EQUIVALENT STRENGTH PARAMETERS OF REINFORCED SOIL MASS FOR GLOBAL STABILITY ANALYSIS OF INTERNALLY STABILIZED SYSTEM: \_\_\_\_\_

\* DRAINAGE DESIGN AND/OR ASSUMED WATER PRESSURE: \_\_\_\_\_

\* MINIMUM DEPTH OF TOE COVER: \_\_\_\_\_

\* MAX. ESTIMATED POST-CONSTRUCTION WALL LATERAL MOVEMENT (ROTATION AND TRANSLATION): \_\_\_\_\_

\* MAX. ALLOWABLE SETTLEMENT OR DIFFERENTIAL SETTLEMENT: \_\_\_\_\_

\* MAX. TOE PRESSURES (@ 5' increment to max. height): \_\_\_\_\_

\* SURFACE TREATMENT OF BACKFILL: \_\_\_\_\_

WALL ATTACHMENTS (circle proper applicable items):

* RAIL,	* SOUND BARRIER,	* TRAFFIC SIGN,
* WALL COPING/DRAIN,	* RAIL WITH EMBEDDED POST,	
* RAIL WITH SLEEPER SLAB,	* POST WITH CHAIN LINK,	* FACING PANEL,
* LEVELING PAD.		
* OTHER (SPECIFY) _____		

WALL APPLICATION (circle proper applicable items):

* EARTH RETAINING,	* BRIDGE ABUTMENT,	* EMBANKMENT,
* FLOOD CONTROL,	* UNDERPASS,	* LANDSCAPING.
* OTHER (SPECIFY) _____		

(FORM TO BE FILLED IN WITH COVER LETTER BY APPLICANT)  
(ATTACH MORE SHEETS IF NEEDED)

EXHIBIT 3 CDOT PRE-APPROVAL WALL FORMAT

---

EARTH RETAINING WALL CLASSIFICATION

---

A classification system is the essential part of the description and selection of different earth retaining wall types.

The earth retaining walls can be logically classified into three categories according to basic mechanisms of retention and source of support.

1. An externally stabilized system uses a physical structure to hold the retained soil. The stabilizing forces of this system are either mobilized through the weight of a morpho-stable structure or through the restraints provided by the embedment of wall into the soil, if needed, plus the tieback forces of anchorages.
2. An internally stabilized system involves reinforced soils to retain fills and sustain loads. Adding reinforcement either to the selected fills as earth walls or to the retained earth directly to form a more coherent stable slope. These reinforcements can either be layered reinforcements installed during the bottom-to-top construction of selected fills, or be driven piles or drilled caissons built into the retained soil. All this reinforcement must be oriented properly and extend beyond the potential failure mass.
3. A hybrid or mixed system is one which combines elements of both externally and internally stabilized systems.

The conventional earth retaining wall types can be grouped as gravity walls, semi-gravity walls and non-gravity walls as follows:

The gravity walls derive their capacity through the dead weight of integrated mass which can be either externally or internally stabilized systems. They can further be classified into four types; First is an externally stabilized system, generic walls such as masonry, stone, dumped rock and gabion wall; Second is an externally stabilized system; modular walls which can be either precast concrete or prefabricated metal bin wall; Third is an internally stabilized system; earth walls with either facing covered cuts in situ with doweled with uniformly spaced top-to-bottom constructed nails or selected fills reinforced with tensile reinforcements which can be either metal (inextensible) reinforcements or geo-textile (extensible) reinforcements, and Fourth is an externally stabilized cast-in-place mass concrete wall or low cost cement treated soil wall with anchored precast concrete facings.

The semi-gravity walls derive their capacity through the combination of dead weight and structural resistance. Concrete cantilever walls designed with different shapes can be further classified into two groups; First is the conventional cast in place wall, and Second is a prefabricated system wall, wall with cast-in-place base and all kinds of innovative precast post-tensioned stems. They are, in general, externally stabilized systems and can be either on spread footings or deep foundations such as caissons or piles.



The non-gravity walls derive lateral resistance either by embedment of vertical wall elements into firm ground or by anchorages provided by tiebacks, dowel actions provided by piles or drilled caissons into stabilized zone. They can be classified into: First, an externally stabilized system with embedded cantilever walls, with or without ties such as sheet pile walls or slurry concrete walls with or without multiple anchorages. Second, an internally stabilized system such as creeping slopes externally covered with multi-anchored facings and internally doweled with pile/caisson inclusions.

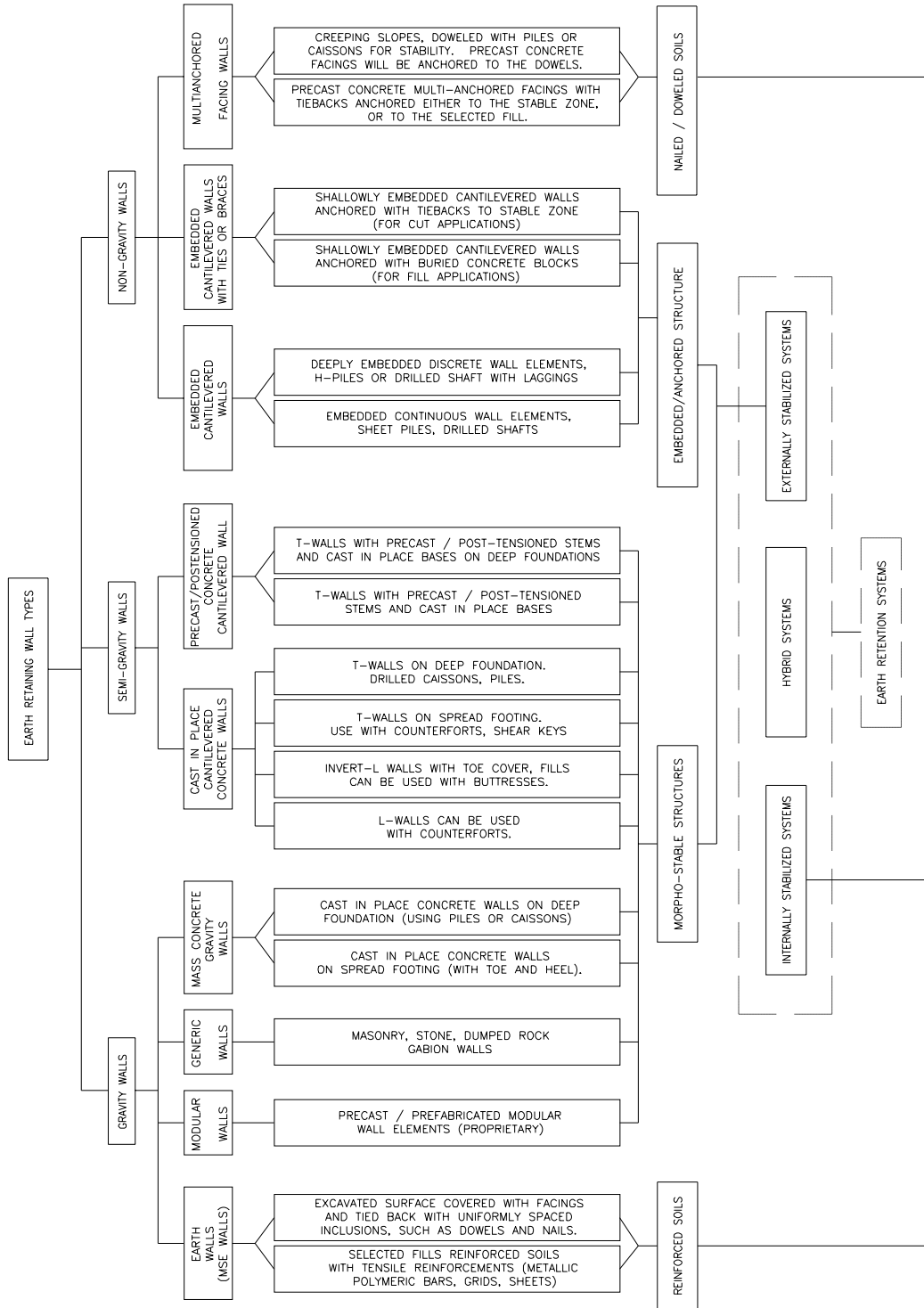

WALL SELECTION FACTORS AND PROCEDURE

The wall selection process is an iteration process which involves cycles of preliminary design and cost estimation. The first step of this process is to define the optimal design problem properly. This includes design objectives and constraints. The objective of almost all design problems is least cost. Costs, such as material and construction are much easier to quantify than that of aesthetic and environmental costs. It is difficult to verify which one of the feasible solutions is the best (i.e. both feasible and optimal). In order to find solutions which are at least feasible, constraints such as serviceability requirements (wall horizontal movement, vertical differential settlement, etc.) and spatial limitations (right of way, underground easement etc.) should be defined as comprehensively as possible. Designs (wall types) which meet the prescribed constraints are all feasible solutions. A rating on these feasible solutions (wall types) is required. Ideally the wall with the highest rank should be adopted for detailed design, and the rest can be used as design alternatives. At the beginning of the selection process, wall names associated with rough sketches should be adequate to screen out unfeasible wall types. As the selection process proceeds, a conceptual design with preliminary dimensions should be generated. Factors affecting the selection of an earth retaining structure are grouped into three categories. There are spatial constraints, behavior constraints and economic considerations as follows:

**5.4.1 SPATIAL CONSTRAINTS**

*\* FUNCTIONS OF WALL \**

- ROADWAY AT FRONT OF WALL.
- ROADWAY AT BACK/TOP OF WALL.
- GRADE SEPARATION OR LANDSCAPING OR NOISE CONTROL.
- RAMP OR UNDERPASS WALL.
- TEMPORARY SHORING OF EXCAVATION.
- STABILITY OF STEEP SIDE SLOPE.
- FLOOD CONTROL.
- BRIDGE ABUTMENT.
- OTHER (SPECIFY) \_\_\_\_\_

*\* SPACE LIMITATIONS AND SITE ACCESSIBILITY \**

- RIGHT OF WAY BOUNDARIES.
- GEOLOGICAL BOUNDARIES.
- ACCESS OF MATERIAL AND EQUIPMENT.
- TEMPORARY STORAGE OF MATERIAL AND EQUIPMENTS.
- MAINTAINING EXISTING TRAFFIC LANES OF WIDENING.
- TEMPORARY AND PERMANENT EASEMENT.
- OTHER (SPECIFY) \_\_\_\_\_

*\* PROPOSED FINISHED PROFILE \**

- USING DIFFERENT COMBINATION OF WALL TYPES ALONG THE WALL ALIGNMENT MAY BE THE OPTIMAL SOLUTION.
- LIMIT OF RADIUS OF WALL HORIZONTAL ALIGNMENT.
- CUT/FILL WITH RESPECT TO ORIGINAL SLOPE.
- MINIMAL SITE DISTURBANCE:
  - ANCHORED WALL WITH MINIMAL CUT.
  - STEPPED-BACK WALL ON TERRACE PROFILE WITH BALANCED CUT/FILL.
  - SUPERIMPOSED/STACKED LOW WALLS.
  - MSE WALL WITH TRUNCATED BASE / TRAPEZOIDAL REINFORCED ZONE.

\* CHECK AVAILABLE SPACE VERSUS REQUIRED DIMENSIONS \*

- WORKING SPACE IN FRONT OF WALL (SHORING, FORMWORK, etc.).
- WALL BASE DIMENSION.
- WALL EMBEDMENT DEPTH.
- EXCAVATION BEHIND WALL.
- UNDERGROUND EASEMENT.
- WALL FRONT FACE BATTERING.
- SUPERIMPOSED WALLS OR TRAPEZOIDAL PROFILE OF WALL BACK.

#### 5.4.2 BEHAVIOR CONSTRAINTS

\* EARTH PRESSURE ESTIMATION (MAGNITUDE AND LOCATION) \*

- The magnitude of the earth pressure exerted on a wall is dependent on the amount of movement that the wall undergoes.
- Rankine or similar method, pressure increases with depth.
- The vertical component of earth pressure is a function of the coefficient of friction and/or relative displacement (settling) between wall (stem, facing and reinforced earth mass) and retained fill.
- Terzaghi and Peck or similar method, pressure might be as great near the top of the wall as its bottom.
- Compaction of confined soil may result in developing of earth pressure greater than active or at rest condition.
- For complex or compound walls such as bridge abutments, battered faced wall, superimposed walls and walls with trapezoidal backs, a global limit equilibrium analysis is required.
- For embedded cantilever wall profile of lateral pressures acting on both sides of wall are affected by the location of center of wall rotation (pivot point) under the dredge line which is construction dependent.
- For multi-anchored embedded cantilever wall using a minimum penetration depth where there is no static pivot point below dredge line, soil pressure profile is anchorage design dependent and should be developed with the recognition of beam-on-elastic foundation.
- At ultimate limit state the location of the horizontal earth pressure resultant moves up from 0.33 to 0.40 of the wall height.

\* GROUND WATER TABLE \*

- reduce hydrostatic pressure.
  - reduce corrosion.
  - prevent soil saturation.
- An appropriate ground water drainage system is required except when water table level prevents settlement of adjacent structure.

\* FOUNDATION PRESSURE ESTIMATION \*

- uniform average pressure by Meyerhof effective width method.
- maximum toe pressure by flexural formula method.

\* ALLOWABLE BEARING CAPACITY ESTIMATION \*

- allowable bearing capacity is limited by and related to preset settlement or differential settlement criteria.
- earth walls integrated with wider flexible bases are allowed higher bearing capacity and tolerate more settlement than rigid walls on spread footings.

\* ALLOWABLE DIFFERENTIAL SETTLEMENT \*

- settlement is a time dependent behavior.
- top of wall settlement is a sum of settlement from wall and from sub-soil strata.

- allowable settlement shall be evaluated by considering tolerable movement of superstructure and wall precast facings.
- simple span bridges tolerate more angular distortion between adjacent footings than continuous span bridges.
- tolerable (vertical and horizontal) movement of wall facing is a function of panel joint width and pattern of connection.

\* EARTH PRESSURE ON WALL FACING \*

- the rigidity and slope of wall facing affects the development of lateral pressure and displacement at facing.
- the earth pressure is reduced with a decrease in facing stiffness while the facing deformation is only slightly increased for a decrease in stiffness.

\* SETTLEMENT AND BEARING CAPACITY IMPROVEMENT TECHNIQUES \*

- surcharge (two-phase construction).
- drainage (wick drain).
- compaction.
- reinforced sub-soil.
- compensated foundation.
- light weight fill material.

\* METHODS OF REDUCING SETTLEMENT ON REINFORCED MASS \*

- increase compaction of fill material.
- using more reinforcements (length, area and spacing of reinforcements).
- cement treated of fills.
- reducing clay content of fill.
- using high density in-situed micro nails.

\* EARTH PRESSURE APPLIED AT FACING \*

- High: facing with post-tensioned anchors.
- Medium/high: MSE wall with full height panels.
- Medium: rigid concrete facing with inextensible reinforcements.
- Medium/low: concrete panel facing with extensible reinforcements.
- Low: concrete panel facing with nailed soil.

\* WALL BASE WIDTH \*

- Wall types, foundation types.
- Allowable bearing capacity of spread footing.
- No tension allowed at heel of spread footing.
- Internal and external stability of wall.
- Reinforcement length to control lateral movement of reinforced earth wall.
- Hybrid walls reduce wall base width.

\* TOE PENETRATION DEPTH OF EMBEDDED CANTILEVER WALL \*

- Water cutoff consideration.
- Heave in front of wall.
- Bearing capacity.
- Stability or passive toe kickout.
- Slope of ground in front of wall.
- Using anchorages.

\* WALL SENSITIVITY TO DIFFERENTIAL SETTLEMENT \*

- High: cast-in-place concrete retaining walls.
- Medium: earth walls with inextensible reinforcements, geo-grid walls with facings, precast modular walls.

- Medium/low: geo-fabric walls without facing.
- Low: gabion walls, crib walls, embedded cantilever walls, multi-anchored cantilever walls.

\* POTENTIAL SETTLEMENT OF RETAINED MASS \*

- High: embedded cantilever walls.
- High/medium: some concrete modular walls, geo-fabric walls.
- Medium: cast-in-place concrete retaining wall, concrete modular walls, geo-grid walls.
- Medium/low: earth walls with inextensible reinforcements.
- Low: multi-anchored embedded cantilever walls.

\* RELATIVE CONSTRUCTION TIME \*

- Long: cast in place concrete walls.
- Medium: earth walls with reinforcements.
- Short: embedded cantilever walls, multi-anchored embedded cantilever walls, precast modular walls.

\* WALL DESIGN LIFE \*

- Structural integrity.
- Color and appearance.

\* LOAD CARRYING CAPACITY AND SETTLEMENT OF DEEP FOUNDATION \*

- Maximum frictional resistance along the pile shaft will be fully mobilized when the relative displacement between the soil and the pile is about 1/4" irrespective of pile size and length.
- Maximum point resistance will not be mobilized until the pile tip has gone through a movement of 10 to 25 percent of the pile width (or diameter). The lower limit applies to driven piles, and the upper limit is for bored piles.
- The ultimate load carrying capacity is the sum of pile point and total frictional resistance.
- Pile to cap compatibility should be considered, especially with battered piles and semi-rigid pile cap connection.
- For the estimation of group efficiency in vertical and horizontal displacement, calculation of pile group, pile diameter, spacing, soil type and total number of piles should be considered.

\* FILL MATERIAL PROPERTIES \*

- The lower the soil friction angle, the higher the internal earth pressure restrained by the wall.
- The lower the soil friction angle, the lower the apparent friction coefficient for frictional reinforcing system.
- The higher the plasticity of the backfill, the greater the possibility of creep deformations, especially when the backfill is wet.
- The greater the percentage of fines in the backfill, the poorer the drainage and more severe the potential problem from high water pressure.
- The more fine grained and plastic the fill, the more potential there is for corrosion of metallic reinforcement.

\* *FILL RETENTION VERSUS CUT RETENTION* \*

<u>FILL RETENTION</u> (bottom-to-top construction)	<u>CUT RETENTION</u> (top-to-bottom construction)
1. Earth Walls (extensible and inextensible tensile reinforcements)	1. Earth Walls (soil nails)
2. All semi-gravity walls	2. All non-gravity walls
3. Modular walls, generic walls and mass concrete walls.	

**5.4.3 ECONOMIC CONSIDERATIONS**\* *Environmental constraints* \*

- ECOLOGICAL IMPACTS ON WET LAND.
- CORROSIVE ENVIRONMENT ON STRUCTURAL DURABILITY.
- WATER POLLUTION, SEDIMENT OR CONTAMINATED MATERIAL.
- NOISE/VIBRATION CONTROL POLICY.
- STREAM ENCROACHMENT.
- FISH/WILDLIFE HABITATION OR MIGRATION ROUTES.
- UNSTABLE SLOPE.
- OTHER (SPECIFY)

\* *Aesthetic constraints* \*-URBAN VERSUS RURAL.

- DESIGN POLICY OF SCENIC ROUTES.
- ACOUSTIC/AESTHETIC PROPERTIES OF WALL FACING.
- ANTI-GRAFFITI WALL FACING.
- AVOIDING VALLEY EFFECT OF LONG/HIGH WALL.
- OTHER (SPECIFY)

\* *Economic factors* \*

- CONSTRUCTION SCHEDULE.
- AVAILABILITY OF FILL MATERIAL.
- SUPPLY OF LABORERS.
- HEAVY EQUIPMENT REQUIREMENTS.
- FORMWORK, TEMPORARY SHORING.
- DEWATERING REQUIREMENTS.
- AVAILABLE STANDARD DESIGNS.
- 'BUY COLORADO' IMPACT.
- TEMPORARY VERSUS PERMANENT WALL AND FUTURE WIDENING
- COST OF DRAINAGE SYSTEM.
- DESIGN AND INSTALLATION OF WALL ATTACHMENTS.
- NEGOTIATED BIDDING AND DESIGN/BUILD ON NON-STANDARD PROJECTS.
- MAINTENANCE COST, READJUSTMENT AND REMODELING.
- UNCERTAINTY OF SITE AND WALL LOADS.
- COMPLEXITY OF PROJECT:
  - HEIGHT DIFFERENCES IN FINISHED OR BASE GRADES.
  - NUMBER OF WALL TURNING POINTS.
  - SCALE OF PROJECT.
  - LENGTH/HEIGHT OF WALL - QUALITY CONTROL OF FILL MATERIAL.
  - POST-TENSIONING, GROUTING, TRENCHING, SLURRY.
  - PILE DRIVING, CAISSON DRILLING.
  - PRE-CASTING, TRANSPORTATION AND INSPECTION.
  - QUANTITY OF EXCAVATION.
  - QUANTITY OF BACKFILL MATERIAL.

- EXPERIENCE AND EQUIPMENT OF LOCAL CONTRACTOR.
- PROPRIETARY PRODUCT AND QUALITY ASSURANCE.
- OTHER (SPECIFY)

small figure

The logical sequence of considering these factors is to reduce the number of the feasible wall types. The first stage of the decision process eliminates the obviously inappropriate walls through spatial and behavior constraints before considering economic factors. The behavior constraints involve the properties of the earth the wall is required to retain and the ground it rests on. A detailed geological investigation and soil property report is needed in the second stage of the decision process. At this stage conceptual designs with dimensioned wall sections and sub-soil strata are required. In the third stage behavior constraints and economic constraints should be repeatedly or simultaneously considered.

After identification of the feasible set of wall types (only a subset of the available walls), the more refined or detailed preliminary designs proceed, then a rating of the these feasible designs should be made.

To work with the factors during the selection process the work sheets attached in Subsection 5.5, along with the properly defined design problem (objectives and constraints), and the requirements of wall cost study as shown in the last page of this Subsection shall be used and form a part of the documentation in support of the final selection(s).

After completing the work sheets, a list of selected wall types with conceptual designs will be generated. A rating matrix shall then be developed for a qualitative evaluation of the selected alternatives. Based on each evaluation factor, a qualitative rating between one and five can be given each alternate. The qualitative ratings are usually multiplied by weight factors reflecting the importance of the factors -- usually, cost and durability related factors are given higher weights than the rest. The alternative(s) with the highest score is (are) then selected for final design and detailed cost estimation.

The intent of this procedure is to identify equally satisfactory alternative wall-types. The plans/specifications will provide the opportunity for the contractor to select from the acceptable alternatives. The designer shall make his decision to assign alternate walls as the case A or B on Page 3 of 3 of Subsection 5.8. The specifications will outline the acceptable alternatives with dimensioned conceptual designs and indicate the requirements for the contractor to submit final site specific details (Subsection 5.8). These submitted (design/build) shop drawings, which clearly establish that the design criteria are satisfied, include but not limited to, aesthetic features, bearing capacity and stability requirements, and design computations



for the alternative site specific selection, signed and sealed by a Colorado licensed P.E., and other data as may be necessary to document compliance with project needs (Subsection 5.7).

#### **5.4.4 EVALUATION FACTORS USED ON SELECTED CONCEPTUAL WALL DESIGNS**

- \* CONSTRUCTIBILITY
- \* MAINTENANCE
- \* SCHEDULE
- \* AESTHETICS (APPEARANCE)
- \* ENVIRONMENT
- \* DURABILITY OR PROVEN EXPERIENCE
- \* AVAILABLE STANDARD DESIGNS
- \* COST (see page 9 of this Subsection)

#### **5.4.5 NOTES ON RATING OF EVALUATION FACTORS**

1. The sum of all weight factors shall be a total of 100 points.
2. The sum of weight points of any two major factors shall be less than or equal to 70 points.
3. For simplicity minor factor(s) can be removed from the rating matrix if they are (is) given the same score on all selected wall types.

WALL GEOMETRY AND CONSTRAINS:  
 WALL HORIZONTAL ALIGNMENT  
 WALL VERTICAL ALIGNMENT(TOP OF WALL ELEVATION)  
 FINISHED GRADE ELEVATIONS(FRONT AND BACK)  
 RIGHT OF WAY LIMITATIONS  
 TOLERANCES OF FINISHED WALL  
 WALL FACADE OR ARCHITECTURAL TREATMENT  
 WALL ATTACHMENTS (BARRIER, RAIL, LIGHT, CULVERT, ETC.)  
 -----  
 BORING LOGS(IN BOARD AND OUT BOARD)



WALL CONCEPTUAL DESIGN  
 (DIMENSIONED PROFILE)

- \* data base of previous project
- \* standard design
- \* generic software/design aid
- \* vendor's software



WALL HEIGHTS VS. COSTS TABLE  
 (detailed itemized costs)

- \* excavation/shoring
- \* structural backfill,  
 reinforced conc. soil  
 reinforcements, tieback  
 anchors
- \* facing/rail/barrier/drainage
- \* backfill

- \* previous cost  
 data books
- \* vendors' information
- \* quantity index method
- \* vendors' site specific  
 price quotes
- \* old reports



WALL HEIGHTS VS. LENGTHS DISTRIBUTION STUDY

- \* total wall length
- \* average height and standard deviation



GROUND IMPROVEMENT COST AND MISC.  
 (including deep foundation)



WALL TOTAL CONSTRUCTION COST

REQUIREMENTS OF WALL COST STUDY

**WALL COST STUDY SPREAD SHEET - TABLE 1 (SAMPLE OF CPI WL)**

FT	UNIT COST PER SQUARE FOOT					COST/ST	COST/SF
WL HT	EXCAV	BACKFILL	CONC	STEEL RAIL		WALL COST	
	\$7.00	\$14.00	\$200	\$0.4		\$140	
4	1.78	1.19	0.33	17.0	1	\$240.0	\$61.30
6	1.89	1.62	0.51	22.0	1	\$290.0	\$48.27
8	2.11	2.38	0.67	27.0	1	\$339.0	\$42.40
-							
-							
-							

**WALL COST STUDY SPREAD SHEET - TABLE 2 (SAMPLE OF MSE WL)**

FT	UNIT COST PER SQUARE FOOT					COST/FT	COST/SF
WL HT	EXCAV	BACKFILL	GRIL	FACING	RAIL	WALL COST	
	\$6.00	\$12.00	\$1.25	\$7.50		\$180.	
4							
6							
8							
-							
-							
-							

**WALL HT DISTRIBUTION AND COST SPREAD SHEET - TABLE 3 (SAMPLE)**

WL HT	STATION NUMBERS	WALL LENGTH	PERCENTAGE OF TOTAL	CPI WALL \$/FT TOTAL	MSE WALL \$/FT TOTAL
4	64100	145	15%	350.5 50750.	340.0 49300.
6	63955	80	22%	440.0 35200.	480.5 38440.
8	36875	60	25%	520.5 31200.	600.0 36000.
-					
-					
-					
TOTAL		900'	100%	<u>\$850,000.</u>	\$650,000.

WORKSHEETS FOR EARTH RETAINING WALL TYPE SELECTION

**NOTES ON USING WORKSHEETS**

1. Factors that can be evaluated in percentage of wall height:
  - Base dimension of spread footing.
  - Embedded depth of wall element into firm ground.
2. Factors that can be described as 'large (high)', 'medium (average)', or 'small (low)':

Quantitative Measurement

  - amount of excavation behind wall.
  - required working space during construction.
  - quantity of backfill material.
  - effort of compaction and control.
  - length of construction time.
  - cost of maintenance.
  - cost of increasing durability.
  - labor usage.
  - lateral movement of retained soil.

Sensitive Measurement:

  - bearing capacity.
  - differential settlement.
3. Factors that can be appraised with 'yes', 'no' or 'question (insufficient information)'
  - Front face battering.
  - Trapezoidal wall back.
  - Using marginal backfill material.
  - Unstable slope.
  - High water table/seepage.
  - Facing as load carrying element.
  - Active (minimal) lateral earth pressure condition.
  - Construction dependant loads.
  - Project scale.
  - Noise/water pollution.
  - Available standard designs.
  - Facing cost.
  - Durability.
4. Factors that can be approximated from recorded height:
  - Maximum wall height.
  - Economical wall height

GRAVITY WALL WORK SHEET

SYSTEM NAMES AND DESCRIPTIONS			BEHAVIOR FACTORS													ECONOMIC FACTORS								
			SPATIAL FACTORS						BEHAVIOR FACTORS							ECONOMIC FACTORS								
			FTG. WIDTH (EMB. DEPTH) TO HEIGHT RATIO	EXCAVATION BEHIND WALL	WORKING SPACE OF WALL	FRONT FACE BATTERING	TRAPEZOIDAL WALL BACK	SENSITIVITY OF MARGINAL BEARING CAPACITY	SENSITIVITY OF DIFFERENTIAL SETTLEMENT	LATERAL MOVEMENT	MARGINAL BACKFILL MATERIAL	UNSTABLE SLOPE	SCOUR AND FLOOD	LOAD CARRYING STRUCTURE	ACTIVE EARTH PRESSURE CONDITION	CONSTRUCTION DEPENDENT LOADS	NOISE/WATER POLLUTION	FILL COMPACTION AND CONTROL	CONSTRUCTION TIME	COST OF MAINTENANCE	AVAILABILITY OF STANDARD DESIGN	LABOR USAGE	FACING AS AN EXTRA COST	SYSTEM DURABILITY PROBLEM
			L	M	S	Y	H	L	Y	Y	Y	Y	Y	Y	L	L	Y	H	Y	H	Y	Y	Y	
			L	M	S	Y	H	L	Y	Y	Y	Y	Y	Y	L	L	Y	H	Y	H	Y	Y	Y	
			L	M	S	Y	H	L	Y	Y	Y	Y	Y	Y	L	L	Y	H	Y	H	Y	Y	Y	
			L	M	S	Y	H	L	Y	Y	Y	Y	Y	Y	L	L	Y	H	Y	H	Y	Y	Y	
			L	M	S	Y	H	L	Y	Y	Y	Y	Y	Y	L	L	Y	H	Y	H	Y	Y	Y	
			L	M	S	Y	H	L	Y	Y	Y	Y	Y	Y	L	L	Y	H	Y	H	Y	Y	Y	
			L	M	S	Y	H	L	Y	Y	Y	Y	Y	Y	L	L	Y	H	Y	H	Y	Y	Y	
			L	M	S	Y	H	L	Y	Y	Y	Y	Y	Y	L	L	Y	H	Y	H	Y	Y	Y	
			L	M	S	Y	H	L	Y	Y	Y	Y	Y	Y	L	L	Y	H	Y	H	Y	Y	Y	
			L	M	S	Y	H	L	Y	Y	Y	Y	Y	Y	L	L	Y	H	Y	H	Y	Y	Y	
			L	M	S	Y	H	L	Y	Y	Y	Y	Y	Y	L	L	Y	H	Y	H	Y	Y	Y	
			L	M	S	Y	H	L	Y	Y	Y	Y	Y	Y	L	L	Y	H	Y	H	Y	Y	Y	
			L	M	S	Y	H	L	Y	Y	Y	Y	Y	Y	L	L	Y	H	Y	H	Y	Y	Y	
			L	M	S	Y	H	L	Y	Y	Y	Y	Y	Y	L	L	Y	H	Y	H	Y	Y	Y	
			L	M	S	Y	H	L	Y	Y	Y	Y	Y	Y	L	L	Y	H	Y	H	Y	Y	Y	
			L	M	S	Y	H	L	Y	Y	Y	Y	Y	Y	L	L	Y	H	Y	H	Y	Y	Y	
			L	M	S	Y	H	L	Y	Y	Y	Y	Y	Y	L	L	Y	H	Y	H	Y	Y	Y	
			L	M	S	Y	H	L	Y	Y	Y	Y	Y	Y	L	L	Y	H	Y	H	Y	Y	Y	
			L	M	S	Y	H	L	Y	Y	Y	Y	Y	Y	L	L	Y	H	Y	H	Y	Y	Y	
			L	M	S	Y	H	L	Y	Y	Y	Y	Y	Y	L	L	Y	H	Y	H	Y	Y	Y	
			L	M	S	Y	H	L	Y	Y	Y	Y	Y	Y	L	L	Y	H	Y	H	Y	Y	Y	
			L	M	S	Y	H	L	Y	Y	Y	Y	Y	Y	L	L	Y	H	Y	H	Y	Y	Y	
			L	M	S	Y	H	L	Y	Y	Y	Y	Y	Y	L	L	Y	H	Y	H	Y	Y	Y	
			L	M	S	Y	H	L	Y	Y	Y	Y	Y	Y	L	L	Y	H	Y	H	Y	Y	Y	
			L	M	S	Y	H	L	Y	Y	Y	Y	Y	Y	L	L	Y	H	Y	H	Y	Y	Y	
			L	M	S	Y	H	L	Y	Y	Y	Y	Y	Y	L	L	Y	H	Y	H	Y	Y	Y	
			L	M	S	Y	H	L	Y	Y	Y	Y	Y	Y	L	L	Y	H	Y	H	Y	Y	Y	
			L	M	S	Y	H	L	Y	Y	Y	Y	Y	Y	L	L	Y	H	Y	H	Y	Y	Y	
			L	M	S	Y	H	L	Y	Y	Y	Y	Y	Y	L	L	Y	H	Y	H	Y	Y	Y	
			L	M	S	Y	H	L	Y	Y	Y	Y	Y	Y	L	L	Y	H	Y	H	Y	Y	Y	
			L	M	S	Y	H	L	Y	Y	Y	Y	Y	Y	L	L	Y	H	Y	H	Y	Y	Y	
			L	M	S	Y	H	L	Y	Y	Y	Y	Y	Y	L	L	Y	H	Y	H	Y	Y	Y	
			L	M	S	Y	H	L	Y	Y	Y	Y	Y	Y	L	L	Y	H	Y	H	Y	Y	Y	
			L	M	S	Y	H	L	Y	Y	Y	Y	Y	Y	L	L	Y	H	Y	H	Y	Y	Y	
			L	M	S	Y	H	L	Y	Y	Y	Y	Y	Y	L	L	Y	H	Y	H	Y	Y	Y	
			L	M	S	Y	H	L	Y	Y	Y	Y	Y	Y	L	L	Y	H	Y	H	Y	Y	Y	
			L	M	S	Y	H	L	Y	Y	Y	Y	Y	Y	L	L	Y	H	Y	H	Y	Y	Y	
			L	M	S	Y	H	L	Y	Y	Y	Y	Y	Y	L	L	Y	H	Y	H	Y	Y	Y	
			L	M	S	Y	H	L	Y	Y	Y	Y	Y	Y	L	L	Y	H	Y	H	Y	Y	Y	
			L	M	S	Y	H	L	Y	Y	Y	Y	Y	Y	L	L	Y	H	Y	H	Y	Y	Y	
			L	M	S	Y	H	L	Y	Y	Y	Y	Y	Y	L	L	Y	H	Y	H	Y	Y	Y	
			L	M	S	Y	H	L	Y	Y	Y	Y	Y	Y	L	L	Y	H	Y	H	Y	Y	Y	
			L	M	S	Y	H	L	Y	Y	Y	Y	Y	Y	L	L	Y	H	Y	H	Y	Y	Y	
			L	M	S	Y	H	L	Y	Y	Y	Y	Y	Y	L	L	Y	H	Y	H	Y	Y	Y	
			L	M	S	Y	H	L	Y	Y	Y	Y	Y	Y	L	L	Y	H	Y	H	Y	Y	Y	
			L	M	S	Y	H	L	Y	Y	Y	Y	Y	Y	L	L	Y	H	Y	H	Y	Y	Y	
			L	M	S	Y	H	L	Y	Y	Y	Y	Y	Y	L	L	Y	H	Y	H	Y	Y	Y	
			L	M	S	Y	H	L	Y	Y	Y	Y	Y	Y	L	L	Y	H	Y	H	Y	Y	Y	
			L	M	S	Y	H	L	Y	Y	Y	Y	Y	Y	L	L	Y	H	Y	H	Y	Y	Y	
			L	M	S	Y	H	L	Y	Y	Y	Y	Y	Y	L	L	Y	H	Y	H	Y	Y	Y	
			L	M	S	Y	H	L	Y	Y	Y	Y	Y	Y	L	L	Y	H	Y	H	Y	Y	Y	
			L	M	S	Y	H	L	Y	Y	Y	Y	Y	Y	L	L	Y	H	Y	H	Y	Y	Y	
			L	M	S	Y	H	L	Y	Y	Y	Y	Y	Y	L	L	Y	H	Y	H	Y	Y	Y	
			L	M	S	Y	H	L	Y	Y	Y	Y	Y	Y	L	L	Y	H	Y	H	Y	Y	Y	
			L	M	S	Y	H	L	Y	Y	Y	Y	Y	Y	L	L	Y	H	Y	H	Y	Y	Y	
			L	M	S	Y	H	L	Y	Y	Y	Y	Y	Y	L	L	Y	H	Y	H	Y	Y	Y	
			L	M	S	Y	H	L	Y	Y	Y	Y	Y	Y	L	L	Y	H	Y	H	Y	Y	Y	
			L	M	S	Y	H	L	Y	Y	Y	Y	Y	Y	L	L	Y	H	Y	H	Y	Y	Y	
			L	M	S	Y	H	L	Y	Y	Y	Y	Y	Y	L	L	Y	H	Y	H	Y	Y	Y	
			L	M	S	Y	H	L	Y	Y	Y	Y	Y	Y	L	L	Y	H	Y	H	Y	Y	Y	
			L	M	S	Y	H	L	Y	Y	Y	Y	Y	Y	L	L	Y	H	Y	H	Y	Y	Y	
			L	M	S	Y	H	L	Y	Y	Y	Y	Y	Y	L	L	Y	H	Y	H	Y	Y	Y	
			L	M	S	Y	H	L	Y	Y	Y	Y	Y	Y	L	L	Y	H	Y	H	Y	Y	Y	
			L	M	S	Y	H	L	Y	Y	Y	Y	Y	Y	L	L	Y	H	Y	H	Y	Y	Y	
			L	M	S	Y	H	L	Y	Y	Y	Y	Y	Y	L	L	Y	H	Y	H	Y	Y	Y	
			L	M	S	Y	H	L	Y	Y	Y	Y	Y	Y	L	L	Y	H	Y	H	Y	Y	Y	
			L	M	S	Y	H	L	Y	Y	Y	Y	Y	Y	L	L	Y	H	Y	H	Y	Y	Y	
			L	M	S	Y	H	L	Y	Y	Y	Y	Y	Y	L	L	Y	H	Y	H	Y	Y	Y	
			L	M	S	Y	H	L	Y	Y	Y	Y	Y	Y	L	L	Y	H	Y	H	Y	Y	Y	
			L	M	S	Y	H	L	Y	Y	Y	Y	Y	Y	L	L	Y	H	Y	H	Y	Y	Y	
			L	M	S	Y	H	L	Y	Y	Y	Y	Y	Y	L	L	Y	H	Y	H	Y	Y	Y	
			L	M	S	Y	H	L	Y	Y	Y	Y	Y	Y	L	L	Y	H	Y	H	Y	Y	Y	
			L	M	S	Y	H	L	Y	Y	Y	Y	Y	Y	L	L	Y	H	Y	H	Y	Y	Y	
			L	M	S	Y	H	L	Y	Y	Y	Y	Y	Y	L	L	Y	H	Y	H	Y	Y	Y	
			L	M	S	Y	H	L	Y	Y	Y	Y	Y	Y	L	L	Y	H	Y	H	Y	Y	Y	
			L	M	S	Y	H	L	Y	Y	Y	Y	Y	Y	L	L	Y	H	Y	H	Y	Y	Y	
			L	M	S	Y	H	L	Y	Y	Y	Y	Y	Y	L	L	Y	H	Y	H	Y	Y		



NON-GRAVITY WALL WORK SHEET

SYSTEM NAMES AND DESCRIPTIONS		SPATIAL FACTORS										BEHAVIOR FACTORS										ECONOMIC FACTORS			
		FTG. WIDTH (EMB. DEPTH) TO HEIGHT RATIO	EXCAVATION BEHIND WALL	WORKING SPACE OF WALL	FRONT FACE BATTERING	SENSITIVITY OF WALL BACK	SENSITIVITY OF MARGINAL SETTLEMENT	LATERAL MOVEMENT	MARGINAL BACKFILL BEARING CAPACITY	UNSTABLE SLOPE	SCOUR AND FLOOD	HIGH WATER TABLE/SEEPAGE	LOAD CARRYING STRUCTURAL FACING	CONSTRUCTION PRESSURE CONDITION	QUANTITY OF BACKFILL MATERIAL	FILL COMPACTION AND CONTROL	PROJECT SCALE AFFECTS COST	AVAILABILITY OF MAINTENANCE	LABOR USAGE	SYSTEM DURABILITY PROBLEM	FACING AS AN EXTRA COST				
MEASUREMENT INDICATORS: L LARGE H HIGH Y YES M MEDIUM M MEDIUM ? S SMALL L LOW N NO		L	L	L	Y	H	H	L	Y	Y	Y	Y	Y	L	L	Y	H	Y	Y	Y					
EMBEDDED CANTILEVER WALLS	SHEET PILES, CONTINUOUS DRILLED CAISSONS, SLURRY TRENCHED CONCRETE DIAPHRAGM WALLS.	M	M	?	M	M	?	?	?	?	?	?	?	M	M	?	M	?	?	?					
	H-PILES, WOOD PILES, CONCRETE PILES, DRILLED CAISSONS WITH LAGGINGS, TWO ROWS OF CLOSE-PACKED CAISSONS.	S	S	N	L	L	S	N	N	N	N	N	N	S	L	S	N	L	N	N					
SHALLOW EMBEDDED CANTILEVERED WALLS WITH TIES OR BRACES	SHALLOW EMBEDDED CONTINUOUS OR DISCRETE CANTILEVERED ELEMENTS ANCHORED WITH BURIED CONCRETE BLOCKS CLOSE TO GROUND.																								
	SHALLOW EMBEDDED CONTINUOUS DISCRETE CANTILEVERED ELEMENTS WITH TIEBACKS ANCHORED TO THE STABILIZED ZONE.																								
MULTI-ANCHORED FACING WALLS	PRECAST CONCRETE MULTI-ANCHORED FACINGS WITH TIEBACKS ANCHORED EITHER TO THE STABILIZED ZONE, OR TO THE SELECTED FILL.																								
	CREEPING SLOPES DOWELED WITH CAISSONS OR PILES FOR STABILITY. PRECAST CONCRETE FACINGS ARE ANCHORED TO THE DOWELS.																								
TYPICAL ILLUSTRATIONS																									





EARTH RETAINING WALL MEASUREMENT AND PAYMENT

1. Earth retaining structures will be measured and paid for by the square foot. Regardless of the type of earth retaining structure actually constructed (default or alternate wall), and regardless of footing type, the square foot area computed for payment shall be based on vertical heights which are defined by the top of wall elevation and the elevation 18" down from finished grade at the face of wall. In order to accommodate a variable base, the computations shall be made at 20 foot maximum intervals from the beginning to the end station shown on the plans for the default wall design.
2. The unit price bid defined above shall be full compensation for furnishing, handling, and placing of concrete materials; fabricating curing and finishing the wall face; finishing and placing all means of soil reinforcements, joint fillers, waterstops, filter material and incidentals; for all reinforcing steel; for all excavation; for all backfill, including select backfill; for all labor and material required to construct wall facing and concrete leveling pads to the line and grades as shown on the plans; wall erection; sprinkling and rolling for granular backfill material; for finishing and placing all temporary shoring, including soldier shafts or piling; cost of all means of subsoil improvement; deep foundation cost of additional subsoil exploration; and for all labor, tools, equipments and incidentals necessary to complete the work. The unit price bid shall apply for the default wall selection shown on the plans or any allowable alternate which the Contractor elects to construct.
3. An average wall height and standard deviation shall be computed and marked on the default wall design drawing by the designer for record and future cost estimation.
4. Payment of earth retaining wall project shall conform to both Subsection 5.3 (wall classification) and CDOH ITEM BOOK. For retaining wall project allowing alternates payment shall be made under:

<u>Pay Item</u>	<u>Pay Unit</u>
Alternate Retaining Wall (wall descriptions)	Sq Ft

For the purpose of useful record and future selection study, wall descriptions shall contain wall type, wall length, wall average height/standard deviation, type of facing, type of foundation improvement, barrier and rail if applicable.

REQUIREMENTS FOR CONSTRUCTION OF ALTERNATE WALL

1. The successful bidder will be required to indicate the wall type he intends to construct by written notice within three working days after contract award if the wall is not default wall.
2. The Contractor shall submit a detailed design and shop drawings of a proposed alternate wall and have it approved no less than 30 days prior to the beginning of wall construction. The department retains the right to require the construction of the default wall if the Contractor is unable to furnish a satisfactory detailed design or shop drawings to meet the requirement of this Subsection. Any project delay costs resulting from this action by the Department shall be at the expense of the Contractor nor will a project time extension be granted.
3. There will be no allowance of time extension of the contract scheduled completion date for the construction of alternate wall.
4. A plan and elevation sheet or sheets for a proposed alternate wall shall follow the format of the plan drawings for the default wall. They shall contain but not limited by the following:
  - A. An elevation view of the wall which shall indicate the elevation at the top of wall, at all horizontal and vertical break points and at least every 50 foot along the wall for case with segmental facing, elevations at the top of leveling pads and footings, the distance along the face of wall to all steps in the footing and leveling pads, the designation as to the type of panel the length, size and number of mesh or strips, and the distance along the face of wall to where changes in length of the mesh or strips occur, and the location of the original and final ground lines.
  - B. A plan view of the wall which shall indicate the offset from the construction centerline to the face of wall at all changes in horizontal alignment, the limit on the dimension of the widest mesh or strip and the size and the centerline of any structure or pipe which is behind or passes under or through the wall.
  - C. Any general notes required for design and construction of the wall.
  - D. A listing of the summary of quantities provided on the elevation sheet of each wall for all items including incidental items.
  - E. Cross section showing limits of construction and fill sections, limits and extent of select granular backfill material placed above original ground, and of the location at any structure or pipe together with the treatment strips in the vicinity of each pipe.
  - F. Limits and extent of reinforced soil volume.

5. All details including reinforcing bar bending details. Bar details such as rail and barrier shall be in accordance with Department Standards.
6. All details for foundations and leveling pads, including details for steps in the footings or leveling pads, as well as allowable and actual maximum bearing pressures.
7. All facing elements shall be detailed. The details shall show all dimensions necessary to construct the element, all reinforcing steel in the element, and the location of reinforcement element attachment devices embedded in the facing.
8. All details for connections to traffic barriers, coping, parapets, noise wall, and attached lighting shall be shown.
9. Details of the beginning and end of wall including details of connection to the adjacent wall if different wall types are used side by side.
10. Design computations shall include, but are not limited to internal and external, wall stability, bearing capacity and settlement, drainage or waterstop membrane, durability or corrosion protection. The computations shall include a detailed explanation of any symbols and computer programs used in the design of walls.
11. The plans shall be prepared and signed by a professional engineer, licensed in the state of Colorado. Two sets of design drawings and detail design computations shall be submitted to the Bridge Engineer or Branch through the Project Engineer for record purposes. Except in unusual circumstance, such as where insufficient information is submitted for a proper review, it is expected that the Department will issue a notice to proceed within 30 days.

REQUIREMENTS FOR ASSIGNING ALTERNATE WALLS

1. When a designer deems an alternate wall or walls to be appropriate in a given location, in addition to default wall design, he shall study a conceptual design of at least one typical section wall of less than 300' in total length. For walls of 300 feet or longer a conceptual design shall be studied for every 200 feet length of wall. The conceptual design shall include the minimum safety requirements as common to all wall types which is an evaluation of the external stability of the wall against overturning, sliding, bearing/vertical and horizontal movement and global soil shear failure.
2. In those instances where proprietary products are assigned as alternate walls the designer shall provide a matrix or summary of acceptable product names along with the appropriate beginning and ending stations. It is desirable that at least three proprietary product options be named; however, until such time as the Department's approved product list contains at least three systems, as many as possible systems shall be named. If a cast-in-place wall on a spread footing is selected as the default wall, no less than two proprietary systems shall be identified.
3. Mechanically Stabilized Earth (M.S.E.) walls are considered to be a generic wall system and may be reinforced using wire mesh, metal strap, geo-grid or geofabric systems. If M.S.E. wall type is elected as default, the designer may either design it as generic and allow alternates or she/he may adopt/assign proprietary products in the design as alternate with no default. The requirements of this Subsection for assigning alternate walls with no default shall be applied to modular wall as well.
4. Unless otherwise noted the alternate wall facing type and architecture shall meet the requirements specified for the default wall system.
5. The designer shall indicate that special attention is needed for all walls, including alternate wall systems for the following conditions:
  - Where storm drains, underground utilities, and/or conduits pass through or are continuous and parallel to the wall alignment.
  - Where barrier and/or sign mounting systems are required.
  - Where backfill drainage system is required.
  - Where low bearing capacity exists.
  - Where any other special requirements exist.
6. The designer shall provide LOG OF TEST BORING'S on the final plans which give enough information to support the default wall design and to facilitate the contractor prepared detail design of the identified alternative wall.
7. If the designer selects on-site backfill material for the alternative walls, he shall provide a summary of the site specific material properties from the soils report as well as the minimal

requirement of workmanship and proper drainage system of that backfill material. The wall shall be designed for equivalent fluid weight lateral pressure as described in Subsection 5.9.

8. The CDOT wall design decision matrix is shown on page 3 of this Subsection. The assignment of alternate walls shall be based on a documented wall selection study report using the procedures outlined in Subsection 5.4 and 5.5. For a long wall, the selection of a combination of different wall types may result in the optimum solution.
9. The designer is responsible for preparing a complete set of stand-alone design drawings and specifications for each alternate wall that is to be included in the project's contract documents along with the default wall. This applies to both Case A and Case B alternate walls, as defined by the decision matrix on the following sheet. The contents of this independent set of plans and specifications shall include, but not be limited to, the following:
  - A. A site plan showing the locations of all numbered walls and the relative location of the subject wall.
  - B. A complete description of the wall's geometry, which shall include wall alignment, the layout line, contour lines, utility lines, drainage lines as well as landscape features and nearby structures.
  - C. A plan and elevation view of the wall. The total square facial footage with average wall height and standard deviation (or range of height) per Subsection 5.6 shall be given.
  - D. Cross sectional views at appropriate intervals, showing the minimum allowable dimensions of wall components if applicable. These views shall show, but not be limited to, the following:
    - Original and finished grade profile.
    - Type, and compaction requirements, of backfill material.
    - The minimum or range of wall dimensions.
    - The type of reinforcement and its minimum length.
    - Wall front erosion condition and backslope protection.
    - The minimum embedment depth and size of footing.
    - The drainage system along and across the wall.
    - The location of the salt barrier membrane.
    - The facing system and its connection to reinforcement.
    - The rail/sleeper slab, sound barrier, and any high-mast lighting.
    - Any overexcavation or bearing capacity improvement scheme.
    - The architectural requirements of the wall facing.
  - E. Boring logs, and a phone number for accessing the geology report. The following information shall also be provided as necessary to implement the designer's intent for the foundation:
    - A summary of applicable information from the geology report.
    - The acceptable foundation types and their corresponding allowables for bearing capacity and settlement.

WALL DESIGN DECISION MATRIX			
CASES	DEFAULT WALL	ALTERNATE WALLS	DESCRIPTIONS
A	N/A	YES	Height less or equal to 16 feet with class 1 backfill, toe pressure 3 ksf or less, secondary or temporary wall, no bearing capacity and/or settlement problems, mse or modular proprietary walls.
B	YES	YES	Walls on spread footing with correctable settlement and bearing capacity problems, alternate designs tend to be cost effective, or need attention on wall geometry, facade, rail, attachments, site specific detailed design, on-site backfills.
C	YES	YES	Special walls, foundation on difficult soil or site specific marginal backfill material, walls need deep foundation, scour protection, walls inappropriate to design separately.
REMARKS:			
<ul style="list-style-type: none"> <li>▶ Case A - Designer shall provide wall alignment, grading, wall geometry, architectural specials, etc., assign alternates but no default detail design. Contractor shall provide the signed and sealed detail design/shop drawings for the alternates she/he selects to build</li> <li>▶ Case B - Designer shall provide a full design for the default walls and conceptual designs for the alternative walls. Contractor shall provide the signed and sealed detailed design/shop drawings for the alternate wall if he/she elects no to build the default wall.</li> <li>▶ Case C - Designer shall provide a full design and not allow an alternate as documented in wall selection report.</li> <li>▶ A combination of different cases may be applied along the same alignment for a long wall</li> </ul>			

## Assignment of Alternate Walls

DESIGN PROCEDURES OF A CANTILEVER RETAINING WALL

CDOH Standard Specifications for Road and Bridge Construction will govern the selection and use of backfill materials, including backfill materials behind retaining walls. CDOH Specification Item 703.08 makes reference to Structural Backfill Classes I and II. In most cases these backfill materials shall be assumed in the design of retaining walls as follows.

1. With a proper drainage system and backfilling controlled such that no compaction induced lateral loads are applied to the wall, the Class I or better material may be used. The assumption of a minimal lateral earth pressure of 30 psf/ft (equivalent fluid weight) for level backfills or 40 psf/ft for 2:1 sloped fills shall be acceptable.
2. Class II backfill materials is assumed on site inorganic material; however, depending upon its class designation will need to be designed for varying equivalent fluid weight lateral pressures as contained on page 4 of this Subsection. Therefore, should the designer select a Class II backfill it is incumbent upon him to more clearly specify the backfill material be a supplemental project special provision in order that he use an appropriate equivalent fluid weight lateral pressure for design.

With the design aids provided on pages 4 to 7 of this Subsection, the design of a cantilever cast-in-place retaining wall, based on the Rankine Theory of earth pressure, shall proceed as follows.

1. Obtain soil parameters for both backfill and foundation. Usually the cohesionless backfill as shown by the crosshatched part behind wall on page 5 is slightly larger than Rankine zone. This enables designer to use the properties of backfill material to estimate earth loads, otherwise the properties of retained material shall be used.
2. Determine the design cases and load combinations, such as:
  - a. SLOPED OR LEVELED FILL W/O RAIL      D + E
  - b. LEVELED FILL W/RAIL                      D + E + SC (Surcharge)
  - c. LEVELED FILL W/RAIL                      D + E + RI (Rail Impact)
  - d. LEVELED FILL W/RAIL & FENCE            D + E + SC + W
3. Determine the overall design height including footing thickness (T) and stem height (H), and select trial footing width dimension (B). Usually the toe width (b) is approximately 1/3 to 1/2 of B. The ratio of footing width to overall height shall be in the range from 0.4 to 0.8 for T-shape walls as shown by the design preliminaries on pages 6 and 7 of this Subsection. In these preliminaries, wide base L-shape walls (footing width to height ratios are larger than 0.8) are used for low wall heights (less than 10'), and the factor of safety with respect to overturning is relaxed from a minimum of 2.0 to 1.5 when considering lateral earth pressure that may be relieved by rail impact (Case:D+E+RI).

4. Draw a vertical line from the back face of footing to the top of fill. This line serves as the boundary of the free body to which the earth pressure is applied. The applied active earth pressure shall be estimated by Rankine theory, and direction assumed parallel to the backfill surface. Compute the resultant (P) of the applied earth pressure and associated loads. Resolve P into its horizontal and vertical components (Ph & Pv) and apply it at 1/3 of the total height (TH) of the imaginary boundary from the bottom of footing.
5. Take a free body of the stem and compute the loads applied at the top of stem as well as loads along the stem (height H), and find the moment and shear envelope to meet all the design cases at several points along the height. The WSD method and the concept of shear friction shall be used to calculate the shear strength at the cold joint between footing and stem.
6. Compute the weight (Wt) which is the sum of the weight of concrete and the weight of soil bounded by the back of the concrete wall and the vertical line defined by the step 4 above. Find the distance from the extremity of toe to the line of action of Wt which is the stabilizing moment arm (a).
7. Compute the overturning moment (OM) applied to wall body with respect to the tip of toe as:

$$OM = Ph * TH/3,$$

compute the resisting moment (RM) with respect to the tip of toe as

$$RM = (Wt * a) + (Pv * B),$$

and the factor of safety against overturning is

$$\begin{aligned} \text{F.S. (overturning)} &= RM/OM \\ &= [(Wt * a) + (Pv * B)] / (Ph * TH/3). \end{aligned}$$

The required F.S. (overturning) shall be equal to or greater than 2.0 unless otherwise accepted and documented by the Engineer (See step 3).

8. Compute the eccentricity (ec) of the applied load with respect to the center of footing through calculating the net moment (NM),

$$\begin{aligned} NM &= RM - OM, \\ ec &= (B/2) - (NM/Wt), \end{aligned}$$

The resultant shall be within the middle third of the footing width, i.e. |ec| less than or equal to (B/6) to avoid tensile action at heel.

9. For simplicity toe pressure (q) can be evaluated and checked by the following equations:

$$q = (Wt/B) * (1 + 6 * ec/B),$$

The toe pressure (q) shall be equal to or less than the allowable bearing capacity as noted by the soils report. Toe pressure is most effectively reduced by increasing the toe dimension.



10. The footing, both toe and heel, shall be designed by WSD for soil reaction acting upward and all superimposed loads acting downward. The heel design loads shall include a portion of the vertical component (Pv) of earth pressure which is applied to heel as shown on page 4 of this Subsection. For the toe design loads and stability, the weight of the overburden shall not be used if this soil could potentially be displaced at some time during the life of the wall.
11. Check factor of safety against sliding without using shear key. The coefficient of friction between soil and concrete is approximated to be  $\tan(2/3 * \emptyset)$ . Neglect the passive soil resistance in front of toe. The sliding resistance (SR) can be evaluated as:

$$SR = (Wt + Pv) * \tan (2/3 * \emptyset).$$

The required F.S. (sliding) which is (SR/Ph) shall be equal to or greater than 1.5. If F.S. (sliding) < 1.5, then either the width of footing shall be increased or a shear key shall be installed at the bottom of footing.

If shear key is the choice, the depth of the inert block (c) is computed by the sum of the key depth KD and the assumed effective wedge depth which is approximated to be half the distance between the toe and the front face of shear key (b1/2). Using the inert block concept and knowing the equivalent fluid weight ( $\gamma_p$ ) of passive soil pressure, and neglecting the top one foot of the toe overburden (TO), the toe passive resistance (Pp) is

$$Pp = 0.5 * \gamma_p * [ (TO + T + c - 1)^2 - (TO + T - 1)^2 ].$$

Total sliding resistance (F) from friction is the sum of the horizontal component of the resistance from toe to shear key (f1) and the resistance from shear key to heel (f2), then

$$F = [\text{horizontal component of } f1] + [f2] \\ = [(\cos(2/3 \emptyset))^2 * R1 * \tan(\emptyset)] + [R2 * \tan(2/3 \emptyset)],$$

where  $\emptyset$ : internal friction angle of base soil,  
 R1: soil upward reaction between toe and key,  
 R2: soil upward reaction between key and heel.

Sliding resistance is

$$SR = F + Pp.$$

The F.S.(sliding) which is (SR/Ph) shall be equal to or greater than 1.5.

12. Except step 5 which is stem design, repeat steps 3 through 11 as appropriate until all design requirements are satisfied.

CDOT STRUCTURAL BACKFILL CLASS DESIGNATION	TYPE OF SOIL COMPACTION CONFORMS WITH AASHTO 90-95% T180	TYPICAL VALUES FOR EQUIVALENT FLUID UNIT WEIGHT OF SOILS (PCF)	
		LEVEL BACKFILL	2 (H) ON 1 (V) BACKFILL
BORROWED SELECTED COARSE GRAINED SOILS GRADATION PER 703.08  CLASS I <sup>4</sup>	LOOSE SAND OR GRAVEL	40 (ACTIVE)	50 (ACTIVE)
		55 (AT REST)	65 (AT REST)
	MEDIUM DENSE SAND OR GRAVEL	35 (ACTIVE)	45 (ACTIVE)
		50 (AT REST)	60 (AT REST)
	DENSE <sup>5</sup> SAND AR GRAVEL 95% p T180	30 (ACTIVE)	40 (ACTIVE)
		45 (AT REST)	55 (AT REST)
ON-SITE INORGANIC COARSE GRAINED SOILS, LOW % OF FINES  CLASS II-A <sup>6</sup>	COMPACTED CLAYEY SANDY GRAVEL	40 (ACTIVE)	50 (ACTIVE)
		60 (AT REST)	70 (AT REST)
	COMPACTED CLAYEY SILTY GRAVEL	45 (ACTIVE)	55 (ACTIVE)
		70 (AT REST)	80 (AT REST)
ON-SITE INORGANIC LL < 50%  CLASS II-B	COMPACTED SILTY/SANDY GRAVELLY LOW/MEDIUM PLASTICITY LEAN CLAY	SITE SPECIFIC MATERIAL, USE WITH SPECIAL ATTENTION, SEE GEOTECHNICAL ENGINEER AND NEED SOILS REPORT ON WORKMANSHIP OF COMPACTION, DRAINAGE DESIGN AND WATERSTOP MEMBRANE.	
ON-SITE INORGANIC LL > 50%  CLASS II-C	FAT CLAY, ELASTIC SILT WHICH CAN BECOME SATURATED	NOT RECOMMENDED	

## FOOTNOTES:

1. AT REST PRESSURE SHALL BE USED FOR EARTH THAT DOES NOT DEFLECT OR MORE.
2. ACTIVE PRESSURE STATE IS DEFINED BY MOVEMENT AT THE TOP OF WALL OF 1/240 OF THE WALL HEIGHT.
3. THE EFFECT OF ADDITIONAL EARTH PRESSURE THAT MAY BE INDUCED BY COMPACTION OR WATER SHALL BE ADDED TO THAT OF EARTH PRESSURE.
4. CLASS I: 30% OR MORE RETAINED ON NO. 4 SIEVE AND 80% OR MORE RETAINED ON NO. 200 SIEVE.
5. DENSE: NO LESS THAN 95% DENSITY PER AASHTO T180.
6. CLASS II-A: 50% OR MORE RETAINED ON NO. 200 SIEVE.<sup>3</sup>

Typical Values for Equivalent Fluid Pressure of Soils



C.I.P Concrete T-Wall Preliminaries (1/2)

(MISSING FIGURE)

C.I.P. Concrete T-Wall Preliminaries (2/2)  
(MISSING FIGURE)

---

WINGWALLS FOR U-TYPE ABUTMENTS

---

**WINGWALL DESIGN LENGTH**

The design length of the wingwall shall be from the back face of the abutment and shall end approximately 4 feet beyond the point of intersection of the embankment slope with the finished roadway grade.

**WINGWALL FOUNDATION SUPPORT**

Normally, a wingwall will be cantilevered off of the abutment with no special foundation support needed for the wingwall.

When the required wingwall length exceeds the length for a practical wing cantilevered off the abutment, a retaining wall shall be used along with a nominal length of cantilevered wing to provide the needed wingwall length. The foundation support shall be the same as that of the abutment. This is to reduce the risk of the retaining wall settling, subsequent misalignment, and leaking, and broken joints that are unmaintainable.

**WINGWALL DESIGN LOADS**

The design shall be based on an equivalent fluid pressure of 36 pounds per cubic foot and a live load surcharge of 2 feet of earth. The equivalent fluid pressure and live load surcharge shall be applied to the full depth of the wingwall at the back face of the abutment and to a depth 3 feet below the elevation of the embankment at the outside of the end of the wing. This pattern of loading shall be used only for wingwalls cantilevered off the abutment. Retaining walls shall be fully loaded as required for their design height.

The design of wings cantilevered off the abutment also shall provide for a 16 kip wheel load with impact located 1'-0" from the end of the wingwall. Under this vertical loading condition, a 50 per cent overstress is allowed in combination with other forces.

The design of wingwalls also shall provide for the 10 kip horizontal force applied to the bridge railing and distributed according to AASHTO. Under this horizontal loading condition, no other loads, including earth pressure, need be considered.

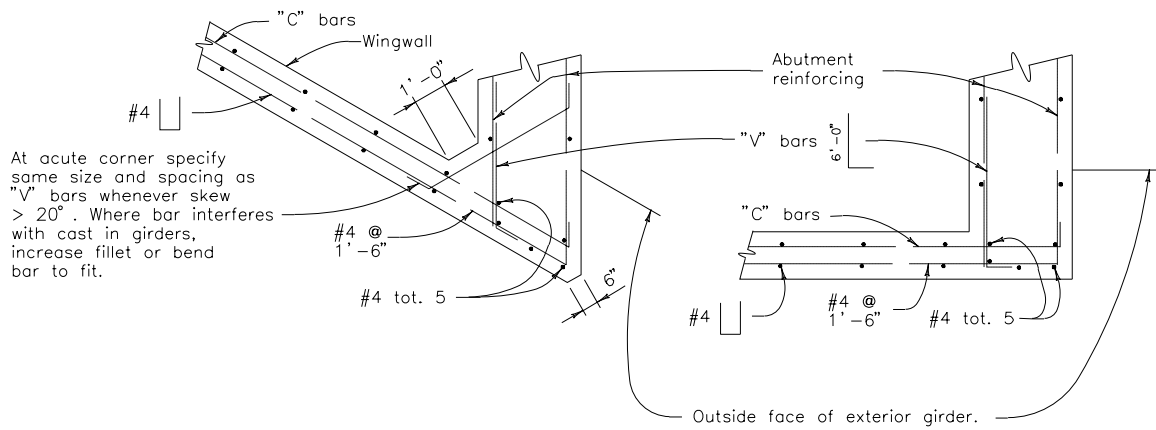
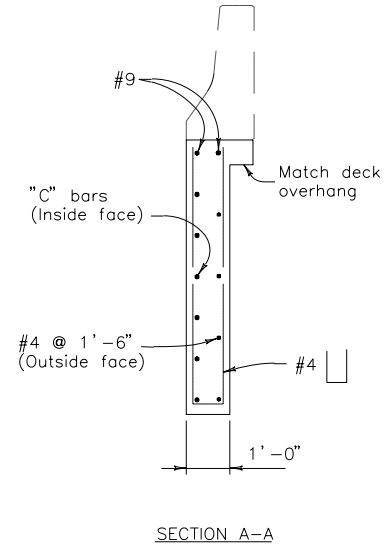
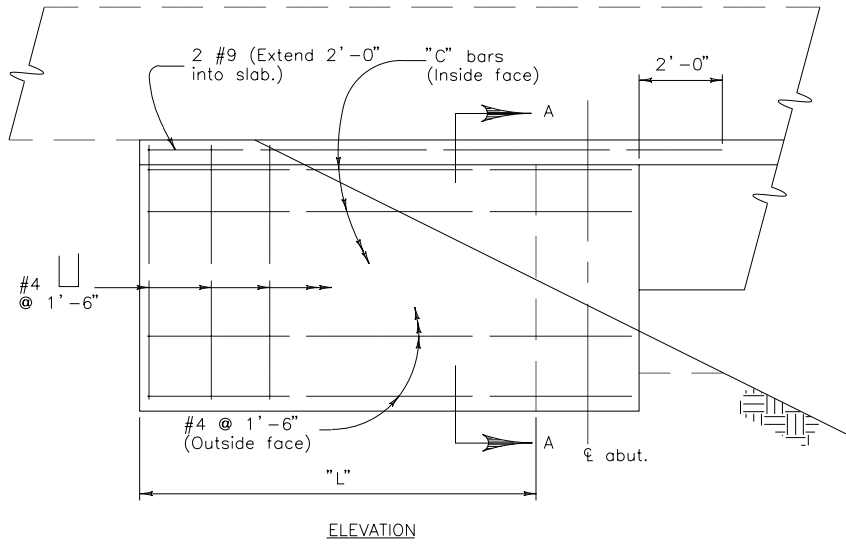

"L"	"C" bars	"V" bars
10'	#5 @ 1'-0"	#4 @ 1'-6"
12'	#5 @ 9"	#4 @ 1'-6"
14'	#6 @ 9"	#4 @ 1'-6"
16'	#7 @ 9"	#5 @ 1'-6"

"L" may be exceeded by 1'-0" before using next longer length. Reinforcement based on 2'-6" wide abutment and 1'-0" wingwall.

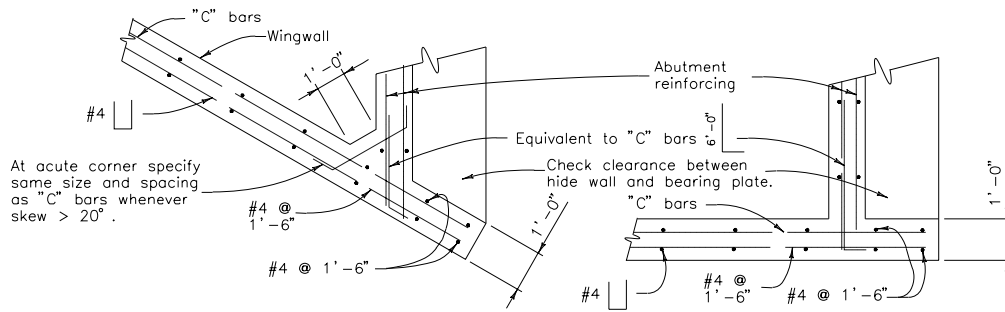
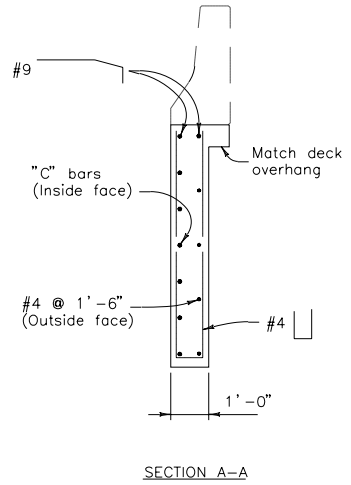
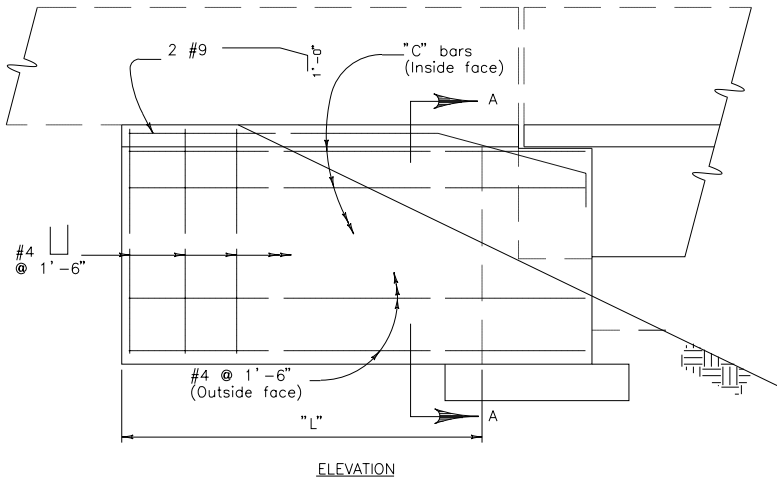

"L"	"C" bars
10'	#5 @ 1'-0"
12'	#5 @ 9"
14'	#6 @ 9"
16'	#7 @ 9"

"L" may be exceeded by 1'-0" before using next longer length.



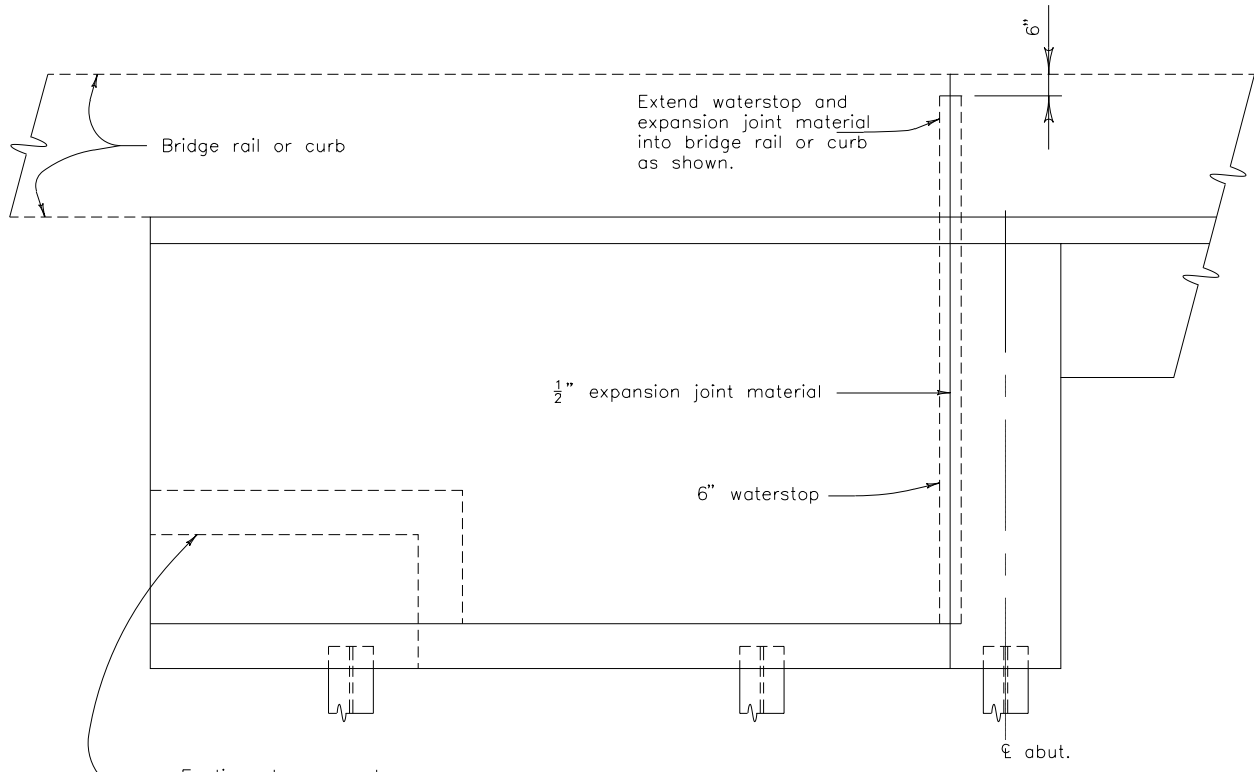

ELEVATION

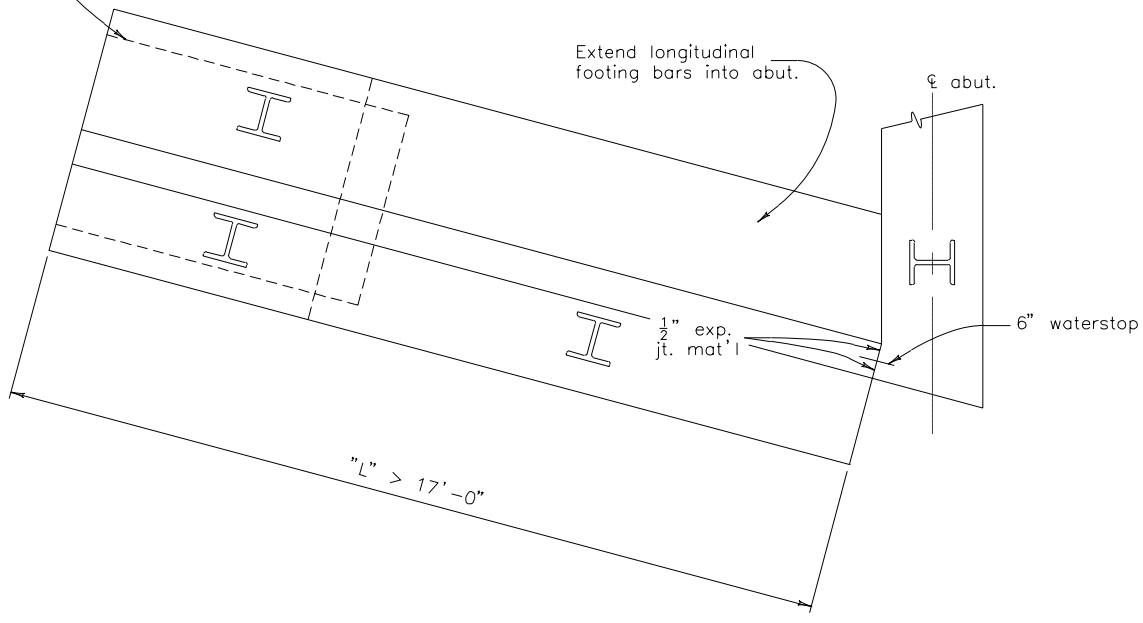

PLAN

COLORADO DEPARTMENT OF TRANSPORTATION STAFF BRIDGE BRIDGE DESIGN MANUAL	Subsection: 7.2 Effective: November 1, 1999 Supersedes: December 31, 1987
INTEGRAL ABUTMENTS	

There are many on system bridges that were designed and built with integral, end diaphragm type abutments on a single row of piles. Although these bridges were built without expansion devices or bearings, they continue to perform satisfactorily. The primary objective of this type of abutment is to eliminate or reduce joints in bridge superstructures. Secondly it can simplify design, detailing, and construction. The integral abutment eliminates bearings and reduces foundation requirements by removing overturning moments from the foundation design.

Integral, end diaphragm type, abutments without expansion devices or bearings shall be used where continuous structure lengths are less than the following. These lengths are based on the center of motion located at the middle of the bridge, and a temperature range of motion of 50 mm (2 in.). The temperature range assumed is 45 degree C (80 degree F) for concrete decked steel structures and 40 degree C (70 degree F) for concrete structures, as per the *AASHTO Guide Specifications for Thermal Effects in Concrete Bridge Superstructures*:

<u>TYPE OF GIRDER</u>	<u>MAXIMUM STRUCTURE LENGTH</u>
Steel	195 M (640 Ft.)
Cast place or Precast Concrete	240 M (790 Ft.)

Pretensioned or post-tensioned concrete should have a provision for creep, shrinkage, and elastic shortening, if this shortening plus temperature fall motion exceeds 25 mm (1 in.). Temporary sliding elements between the upper and lower abutment may be used, or details that increase the flexibility of the foundation as discussed below. Steps must also be taken to ensure the movement capability at the end of the approach slab is not exceeded.

Greater lengths may be used if analysis shows that abutment, foundation, and superstructure design limits are not exceeded, and motion at the end of approach slab is within the capabilities there. The calculations backing up the decision shall be included with the design notes for the structure.

In some cases, site conditions and/or design restraints may not allow the use of this type of abutment, but oversized holes drilled for the piling and filled with sand or a cohesive mud (which flows under long term creep shortening) may be used to compensate for a lack of pile flexibility. If caissons or spread foundations are used in lieu of the piles shown on the next page, sliding sheet metal with elastomeric pads may be used on top of caissons or spread foundations when a pinned connection does not provide enough flexibility.

Integral abutments may be placed on shallow or deep foundations behind retaining walls of all types. Integral diaphragms have been founded on old retaining wall stems or old abutment seats as well. Several structures with tall integral abutments have been built with a gap between the abutment and reinforced fill to reduce earth pressures. This could be used to extend the locked up length capability as well. However, it may be impractical to extend the thermal motion capabilities substantially as the joint at the end of the approach slab has a limited capability and this is not a maintainable location for a modular device.

Poorly balanced earth pressures due to severe skews (less than 56 degrees between abutment axis and the allowed direction of motion) may be dealt with by battering piles perpendicular to the planned allowed motion to resist the unbalanced earth pressures.

Standard integral, end diaphragm type, abutment on piling details are shown on the following page.

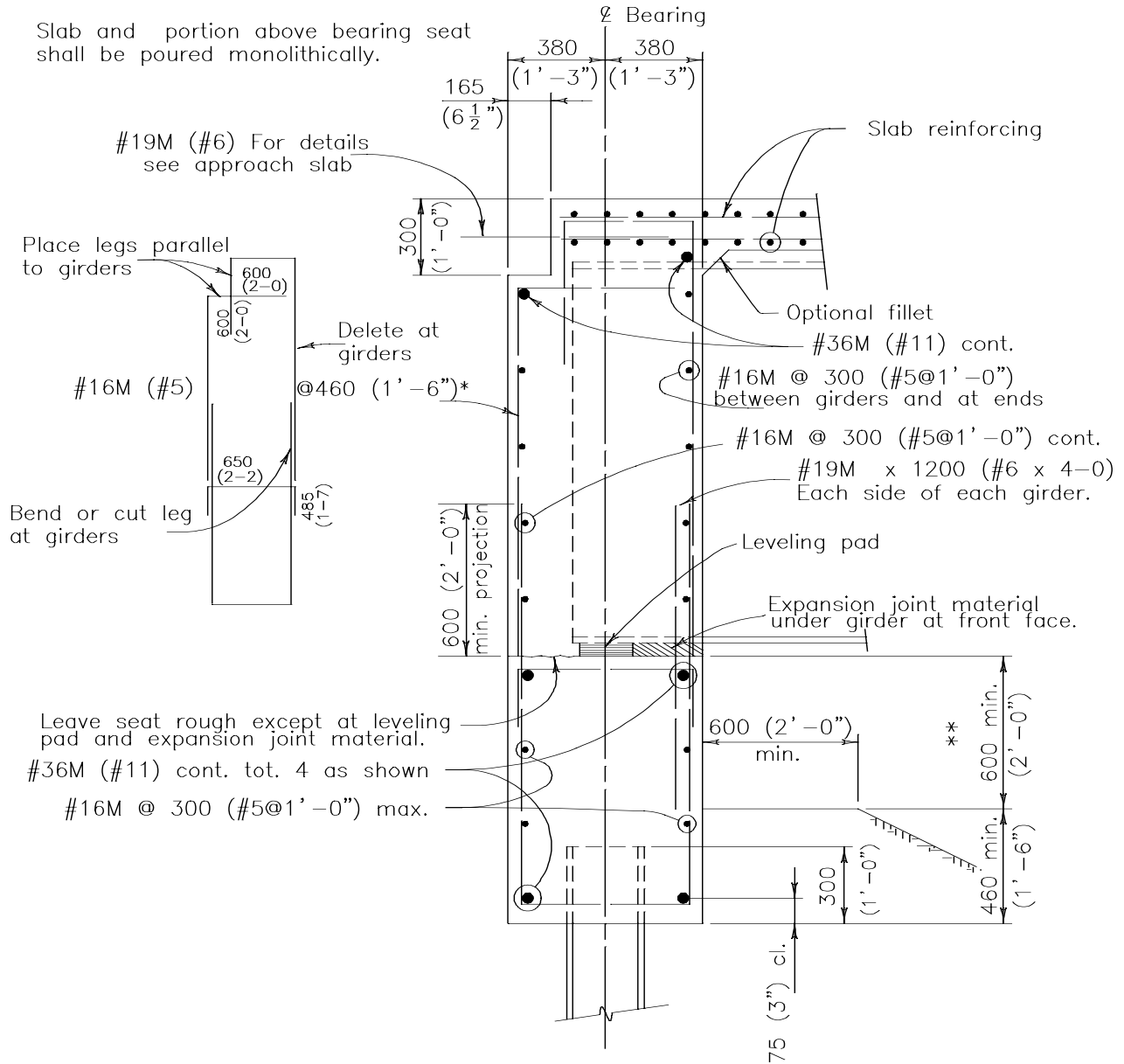

TYPICAL ABUTMENT SECTION

Note: All abutment and wingwall concrete shall be Class D (Bridge)

Extend strands from the bottom of precast sections into abutment, anchor the bottom of steel sections to abutment with studs, bearing stiffeners, anchor bolts, or diaphragm gussets.

\* 300 (1'-0") if structure length longer than 90M (300') or \*\* greater than 1050 (3'-6").

USE OF APPROACH SLAB

---

Approach slabs are used to alleviate problems with settlement of the bridge approaches relative to the bridge deck. The main causes of this settlement are movement of the abutment, settlement and live load compaction of the backfill, moisture, and erosion.

Approach slabs shall be used under the following conditions:

1. Overall structure length greater than 250 feet.
2. Adjacent roadway is concrete.
3. Where high fills may result in approach settlement.
4. When the District requests them.
5. All post-tensioned structures.

In all cases, the approach slab shall be anchored to the abutment. When the adjacent roadway is concrete, an expansion device shall be required between the end of roadway and the end of approach slab.

Approach slab notches shall be provided on all abutments, regardless of whether or not an approach slab will be placed with the original construction.

For details of an approach slab notch, see *Subsection 7.2*.

REINFORCEMENT

**8.1.1 REVISION**

Splice lengths per AASHTO 14th Edition - Section 8.25.2.3, policy change with regard to epoxy-coated reinforcing.

**8.1.2 GENERAL**

Grade 60 reinforcing is required for #4 bars and larger.

No reinforcing smaller than #4 bars shall be used except as shown on standard details for precast members.

Reinforcing larger than #11 i.e., #14 and #18, may be used to eliminate reinforcement congestion if availability from suppliers is verified through the Staff Design Cost Estimates Unit.

Splice lengths shall be shown on the plans in a table included with the General Notes. These lengths are to be Class B splices as modified for 6 inch or greater spacing and shall reflect a 15% increase in length for epoxy coated reinforcing. WHEN ANY OTHER SPLICE LENGTH IS NECESSARY, IT MUST BE DETAILED ON THE PLANS. The following table gives the minimum Class B lap splice length for epoxy coated reinforcing and shall be used in lieu of the length shown in paragraph 4.6 of the Detailing Manual.

BAR SIZE	#4	#5	#6	#7	#8	#9	#10	#11
SPLICE LENGTH	1'-3"	1'-6"	2'-0"	2'-8"	3'-6"	4'-5"	5'-7"	6'-10"

FOR CLASS A  
OR B CONCRETE

SPLICE LENGTH	1'-3"	1'-6"	1'-10"	2'-2"	2'-10"	3'-7"	4'-7"	5'-7"
---------------	-------	-------	--------	-------	--------	-------	-------	-------

FOR CLASS D  
OR S CONCRETE

**8.1.3 EPOXY-COATED REINFORCING**

*8.1.3.A BACKGROUND*

Corrosion in reinforcing steel and the lack of concrete durability are two of the most severe deterioration problems for bridges today. Colorado has experienced both of these problems. In an effort to minimize the problems which became apparent in about the 1960's, various bridge deck protective strategies have been employed, either singularly or in combination, as follows:

*8.1.3.A.1 DURABILITY OF CONCRETE*

Before 1960, concrete durability was usually considered the ability of concrete to resist freeze-thaw deterioration, consisting of scale, popouts and reactive aggregates. Freeze-thaw scale in concrete has been effectively addressed through the incorporation of an air entraining agent that is now a standard practice for bridge decks, other structural concrete, and in fact, concrete generally.

Additionally, the water-cement ratio has been decreased to a point such that in bridge decks a target ratio of 0.44 is specified. Both experience and research results suggest that a variation of  $\pm .03$  from the specified value can be expected. Thus, in any extended life predictions, for the improved water-cement ratio a value of 0.47 is used. In any event, a lower water-cement ratio is not used as an exclusive protection strategy.

This background is merely to record that durability has been addressed by improved water-cement ratio considerations in addition to air entraining agents. It is also included to support the future direction toward lower water cement ratios through the use of admixtures which can provide workability during placement of concrete with reduced water in the mix. A lower water-cement ratio will help limit corrosion if it occurs and is therefore desirable.

#### *8.1.3.A.2 WATERPROOFING MEMBRANES WITH ASPHALT OVERLAYS*

One of the earlier responses to freeze-thaw scale was to use an asphalt overlay. The overlay smoothed the roadway and was thought to be effective in waterproofing the bridge deck against future scaling. Alone, an asphalt overlay proved to have the opposite effect, letting water and salt through the asphalt, but reducing evaporation and keeping the concrete surface saturated with water. With the introduction of membranes, this combination strategy has proven to be fairly effective. The research and experience in Colorado verifies that this combined strategy alone is effective and under certain conditions of low deicer salt applications can provide a deck life in excess of 50 years.

The need for maintenance of the overlay and more particularly the membrane is open to question. Research in Colorado has shown minor failures in the membrane effectiveness. Nationwide research suggests that membranes do deteriorate over time.

Nevertheless, waterproof membranes and asphalt overlays are still in common use throughout Europe and the United States, as well as in Colorado, as a principle protective system. However, it is reasonable to assume that a preventive maintenance approach may need to be initiated to avoid a breakdown in the system's waterproofing effectiveness. The breakdown of the membrane could go undetected because it is hidden from view; and the result being severe deterioration of the deck.

#### *8.1.3.A.3 COVER OVER REINFORCING STEEL*

Increased cover over reinforcing steel was one of the earlier responses to bridge deck deterioration. This direction was taken primarily for two reasons; (1) to ensure a minimum desired cover, it is necessary to start with an increased target cover because of statistical variations in rebar placement resulting from many construction practices; and (2) to prevent the intrusion of deicer chemicals into decks causing corrosion in black rebars and resulting in delamination and subsequent rapid deterioration. Research has generally concluded that covers of 1-3/4" or more decrease the risk of corrosion. To assure a minimum cover of 1-3/4" an extra amount, perhaps 1/2", should be added to allow for construction tolerances, resulting in a cover of 2-1/4". Colorado has responded to this and now requires a minimum of 2-1/2" clear cover to the top mat of reinforcing steel in bridge decks.

#### 8.1.3.A.4 EPOXY-COATED REBARS

Fusion-bonded epoxy-coated reinforcement reached the commercial market in 1976 and almost immediately became a major bridge deck protective strategy. In 1981, an ASTM Standard Specification for Epoxy-Coated Reinforcing Steel Bars was issued. The use of such bars for all practical purposes stopped corrosion of reinforcing steel. As one would expect, the epoxy-coated bars do not affect the physical condition or quality of concrete.

However, it is still important not to abandon vigilance in seeking durable concrete (air-entrainment, low water-cement ratio, and perhaps a silica fume admixture). Epoxy-coated rebars do not bond quite as effectively as black steel therefore have a tendency to "slip" more. Also, some research has indicated increases in crack occurrence and crack width. In some particularly severe corrosion environments (such as Florida), questions are being raised about the effectiveness of epoxy-coated bars. Clearly no such indication has been found.

#### 8.1.3.B POLICY

Recognizing that the totality of a Colorado Bridge Deck Protective Strategy is not the sole prerogative of the Bridge Branch, the following Policy is established for the use of epoxy-coated bars. A continuing effort will be made to consider a total strategy (see Table 1).

The use of epoxy-coated reinforcing bars is intended to be responsive to three categories of needed protection based in part on the anticipated level of de-icing salt applications as follows:

*HIGH* - Bridges, including interstates or urban freeways and expressways, or a bridge in a metropolitan or urbanized area where heavy de-icing salt application is anticipated. These bridges would generally include those within the five counties of Adams, Arapahoe, Denver, Douglas, and Jefferson.

*MODERATE* - Bridges on all other interstates, primary and secondary systems or a bridge along a major arterial where moderate de-icing salt application is anticipated.

*LOW* - Bridges where little or no de-icing salt application is anticipated. Off-system bridges are included in this category unless the jurisdiction responsible for the bridge de-icing indicates otherwise, at which time such bridges will be designed in the moderate category.



*8.1.3.C BOND AND BASIC DEVELOPMENT LENGTH OF EPOXY-COATED REINFORCING*

Recent ACI research indicates that the required development length for epoxy-coated reinforcing is greater than uncoated reinforcing. For epoxy-coated reinforcing, the basic development length,  $l_d$ , in AASHTO Section 8.25 shall be increased by 15% if the clear cover is 3 times the bar diameter or greater, and the clear spacing is 6 times the bar diameter or greater. If the clear cover is less than 3 bar diameters, or the clear spacing is less than 6 bar diameters, the basic development length shall be increased by 50%.

*8.1.3.D SPLICE LENGTHS FOR EPOXY-COATED REINFORCING*

Development length used to calculate Class B and Class C splices shall be increased by 50% or mechanical splices shall be used for epoxy-coated reinforcing when the clear cover is less than 3 times the bar diameter, or the clear spacing is less than 6 times the bar diameter. Splices for slab reinforcing, however, shall be as shown in the general notes or as detailed on the plans. when lap splices become excessively long, use of approved mechanical splices shall be specified.

**TABLE 1**  
**POLICY FOR USE OF EPOXY-COATED REBARS**

MEMBER	TYPE OF PROTECTION	HIGH	MODERATE	LOW
Deck slabs on prestressed concrete Colorado G and box girders, Steel I and box girders.	*Top concrete cover	2-1/2" 1"	2-1/2" 1"	2-1/2" 1"
	*Bottom concrete cover	*Top and bottom mats *(1)	*Top Mat *(1)	----- *(1)
	*Epoxy-coated rebar			
	*Water cement ratio			
Box girders Post-tensioned concrete, reinforced concrete and concrete segmentals.	*Top concrete cover	2-1/2" 1"	2-1/2" 1"	2-1/2" 1"
	*Bottom of top slab cover	*Top and bottom mats of top slab only *Vert. web steel projecting to within 5" of top slab *(1)	*Top mat of top slab only *Vert. web steel projection to within 5" of top slab *(1)	----- *(1)
	*Epoxy-coated rebar			
	*Water cement ratio			
Prestressed DBLT's with no cast in place slab. (Colorado Double-T Std. Bridges)	*Top concrete cover	2-1/2" 1"	2-1/2" 1"	2-1/2" 1"
	*Bottom concrete cover	*Deck and projections into Deck per above two practices *(1)	*Deck and projections into Deck per above two practices *(1)	----- *(1)
	*Epoxy-coated rebar			
	*Water cement ratio			
Reinforced and Post-tensioned concrete slabs.	*Top concrete cover	2-1/2" 1"	2-1/2" 1"	2-1/2" 1"
	*Bottom concrete cover	*Top and bottom mats of slab *(1)	*Top mat of slab *(1)	*(1)
	*Epoxy-coated rebar			
	*Water cement ratio			
Reinforced and Post-tensioned concrete T-Girders	*Top concrete cover	2-1/2" 1"	2-1/2" 1"	2-1/2" 1"
	*Bottom Concrete Cover	*Top and bottom mats of slab *Web steel projecting to within 5" of top slab *(1)	*Top mat of slab *Web steel projecting to within 5" of top slab *(1)	----- ----- *(1)
	*Epoxy-coated rebar			
	*Water cement ratio			
Approach slab	*Top concrete cover	2-1/2"	2-1/2"	2-1/2"
	*Bottom Concrete Cover	3"	3"	3"
	*Epoxy-coated rebar	*Top mat of slab (When there is no asphalt mat)	-----	-----
Prestressed concrete Colorado G and Box Girders	*Epoxy-coated reinforcing	*All stirrup bars and shear connectors projecting into deck and reinforcing within eight feet of an expansion device in the bridge deck	*All stirrup bars and shear connectors projecting into deck and reinforcing within eight feet of an expansion device in the bridge deck	-----

(1) Not to exceed 0.44

**TABLE 1**  
**POLICY FOR USE OF EPOXY-COATED REBARS**  
(Continued)

MEMBER	TYPE OF PROTECTION	HIGH	MODERATE	LOW
Box culverts at grade or having 2'-0" or less cover	*Top slab, bottom slab, and webs concrete cover	*(2)	*(2)	*(2)
	*Epoxy-coated bars	*Top and bottom mats of top slab and projections to within 5" of top slab	*Top mat of top slab and projections to within 5" of top slab	-----
	*Water cement ratio	*(1)	*(1)	*(1)
Box culverts having greater than 2'-0" cover	*Top slab, bottom slab, and webs concrete cover	*(2)	*(2)	*(2)
	*Epoxy-coated bars	-----	-----	-----
	*Water cement ratio	*(2)	*(2)	*(2)
Concrete diaphragms	*End diaphragms epoxy-coated rebars	*All Reinf.	*All Reinf.	-----
	*Interior diaphragms epoxy-coated rebars	-----	-----	-----
Parapets	*Epoxy-coated rebars	*All Reinf.	*All Reinf.	-----
Pier caps on structure with joints over caps	*Concrete cover	*(2)	*(2)	*(2)
	*Epoxy-coated rebars	*All reinf. bars within 5" of top of concrete	*All reinf. bars within 5" of top of concrete	-----
Pier caps on structures with closed decks	*Concrete cover	*(2)	*(2)	*(2)
	*Epoxy-coated bars	*All reinf. bars within 5" of top slab	-----	-----
Columns and caisson	*Concrete cover	*(2)	*(2)	*(2)
	*Epoxy-coated rebars	*All reinf. except caissons (3)	-----	-----
Retaining walls	*Concrete cover	*(2)	*(2)	*(2)
	*Epoxy-coated rebars	----- (3)	-----	-----
Abutments and Wingwalls	*Concrete cover	*(2)	*(2)	*(2)
	*Epoxy-coated rebars	*All reinf. in bridge seat and roadway side of wingwall	*All reinf. in bridge seat	*All reinf. in bridge seat

(1) Not to exceed 0.44

(2) Per AASHTO Standard Specifications

(3) Where retaining wall and columns are within splash zone, approximately 10'-0" beyond edge of roadway shoulder, consideration to use of epoxy-coating of bars projecting above the footing shall be given by the designer.

COLORADO DEPARTMENT OF TRANSPORTATION STAFF BRIDGE BRANCH BRIDGE DESIGN MANUAL	Subsection: 8.2 Effective: December 27, 1991 Supersedes: December 31, 1987
--	--

CONCRETE BRIDGE DECKS

POLICY	COMMENTARY
--------	------------

**GENERAL**

Concrete deck slabs shall have 2-1/2" the top layer of reinforcing. For bare concrete deck slabs with a mechanical saw cut finish, the minimum cover to the top layer of reinforcing shall be 3 inches. Top of concrete box culverts shall have 2-1/2 inches of cover when the fill height is 2 feet or less and 2 inches of cover when fill height is greater than 2'-0".

New concrete deck slabs shall be designed to include the dead load due to 4 inches of asphalt = 48 psf. Bare concrete deck slabs shall be designed to account for the dead load due to 2 inches of future asphalt.

Uplift at supports and girder stresses due to deck pouring sequence shall be considered during design.

The deck pouring sequence should progress from one end of the bridge to the other. When this progressive sequence cannot be accommodated in design, the pouring sequence shall be shown on the plans. All bridges with decks containing more than 300 cubic yards of concrete shall have the pouring sequence shown on the plans. Individual pours within the sequence given by the plans may exceed 300 cubic yards if approved by the Staff Bridge Engineer. Pours should end near the 3/4 point of a span in the direction of pour to minimize cracking in the negative moment regions. The deck pour should progress in the direction of increasing grade. A continuous pour will be an acceptable alternate, unless stated otherwise on the plans.

December 27, 1991	Subsection No. 8.2	Page 2 of 8
POLICY		COMMENTARY

**WATERPROOFING MEMBRANE**

New bridge construction with asphalt pavement or an asphalt overlay over concrete pavement approaching the bridge shall have asphalt and waterproofing membrane applied over the concrete bridge deck and approach slabs. (C1)

C1: Waterproofing membranes and asphalt overlays are used to protect the exposed surface of concrete bridge decks. However, an asphalt overlay may not be desirable where concrete roadway is adjacent to the bridge.

New bridge construction and approach slabs with bare concrete pavement approaching the bridge will require a bare deck with a concrete sealer. (C2)

C2: Concrete sealer will penetrate into the deck to protect against deterioration.

On bridge widening and rehabilitation projects the bridge deck surfacing will be compatible with the conditions at the bridge site. The design engineer will choose the surfacing with consultation of the district preconstruction engineer.

**PERMANENT DECK FORMS**

The use of permanent bridge deck forms is required under the following conditions:

1. Where the structure crosses over an Interstate Highway.
2. Where the forms are deemed necessary for construction purposes.
3. Where form removal may be a problem.
4. When requested by the district.

When permanent bridge deck forms are required, the following note shall be added to the plans, "PERMANENT BRIDGE DECK FORMS ARE REQUIRED."

For all other cases, except as noted below, the use of these deck forms are optional. The following note shall be added to the plans -- "PERMANENT BRIDGE DECK FORMS ARE OPTIONAL."

December 27, 1991	Subsection No. 8.2	Page 3 of 8
POLICY		COMMENTARY

All form flutes, when steel deck forms are used, shall be filled with styrofoam or covered with sheet metal. The dead load used to design the girders and substructure elements shall include an additional 5 psf to account for the steel forms.

Permanent bridge deck forms shall not be used under the following conditions:

1. Between girders or stringers where longitudinal deck construction joints are located.
2. With box culvert structures and cast-in-place post-tensioned T-girder, or box girder bridges.
3. For cantilevered portions of decks.
4. Where architectural constraints would not allow their use.

#### **OVERHANGS**

Deck overhang shoring subject to screed rail loads and construction loads has resulted in excessive deflections and torsional rotation of the exterior girders. In order to eliminate potential construction problems from deflections and rotation, the limits for deck overhangs shall be as follows.

Multi-girder structures with precast concrete or steel I-girders, use the greater of:

$$L = s/3 \quad \text{and}$$

$$L = (b/2 + 12")$$

Steel box girders and multi-girder structures with girders continuously shored, use:

$$L = s/2$$

December 27, 1991	Subsection No. 8.2	Page 4 of 8
POLICY		COMMENTARY

Where:

- s = center-to-center spacing of girders or cast-in-place box webs.
- b = top flange, or web, width.
- L = average overhang width from centerline girder, or web, to edge of deck.

The maximum overhang may exceed the average overhang by not more than 1'-0". The minimum overhang shall extend beyond the edge of the top flange or web by 6 inches to prevent water from dripping onto girder and the bottom flange shall not extend beyond the drip line of the deck.

These overhang criteria may be exceeded with the approval of the Staff Bridge Engineer.

#### DESIGN

To maintain consistency and to standardize the bridge deck details, slab design charts have been prepared for both working stress and load factor design (see attached charts).

These charts are to be used for all slab designs with three or more girders. The deck slab overhang shall be designed for each project.

For concrete decks supported on Colorado prestressed G-Girders, effective span 'S' shall be the clear distance between edges of top flange ('S' shall be measured along direction of transverse rebar). (C3)

Single cell box girders, post-tensioned slabs, and effective slab spans greater than 12'-0" will require project specific designs. Slabs for noncomposite double tees and precast box girders placed side-by-side shall conform to Subsection 8.3.

C3: Regarding Article 3.24.1.2 of the AASHTO Standard Specifications, Staff Bridge does not consider Colorado G-54 and G-68 girders ( $b/t = 5.09 > 4$ ) as thin flange girders because of large continuous fillets. Paragraph (b) of the above Article is appropriate for AASHTO Type V, VI and Bulb tee type girders. Note, paragraph (b) was revised by the 1990 Interims to include thin flange prestressed girders.

December 27, 1991	Subsection No. 8.2	Page 5 of 8
POLICY		COMMENTARY

Composite decks for precast boxes meeting the requirements of the AASHTO Standard Specifications, Article 3.23.4.1, shall conform to the CDOT Bridge Design Manual Subsection 8.3 for composite double tees.

Load factor design shall be used only where the longitudinal girder design is done using the load factor method and as approved by the Staff Bridge Engineer.

The minimum deck thickness shall be 8 inches. (C4)

C4: The minimum deck thickness has been raised to 8 inches due to demonstrated higher performance of thicker decks. Slab longevity increases significantly with increased thickness.



CONCRETE SLAB DESIGN DATA  
WORKING STRESS DESIGN

Effective Span S(ft.)	Top Slab Thick. T(in.)	Top Slab Reinf. Size Spa.	"D" Bars No. of #5 Bars	Bot. Slab Thickness TB(in.)	Bot. Slab Reinf. Size Spa.	
3.50	8.00	#5	8.0"	3	5.50"	#4 14"
3.75	8.00		7.5"	3		
4.00	8.00		7.5"	3		
4.25	8.00		7.0"	3		
4.50	8.00		6.5"	3		
4.75	8.00		6.5"	4		
5.25	8.00		6.0"	4		
5.50	8.00		5.5"	5		
5.75	8.00		5.5"	5		
6.00	8.00		5.0"	5		
6.25	8.00		5.0"	5		
6.50	8.00		5.0"	6		
6.75	8.00		5.0"	6		
7.00	8.00		5.0"	6		
7.25	8.00		5.0"	6	5.50"	
7.50	8.00		5.0"	6	5.75"	14"
7.75	8.00		5.0"		6.00"	13"
8.00	8.00		5.0"	7	6.00"	13"
8.25	8.00		5.0"	7	6.25"	12"
8.50	8.25		5.0"	7	6.50"	12"
8.75	8.25	#5	5.0"	7	6.75"	11"
9.00	8.25	#6	6.5"	8	6.75"	11"
9.25	8.25		6.5"	9	7.00"	11"
9.50	8.25		6.5"	9	7.25"	11"
9.75	8.25		6.5"	9	7.50"	10"
10.00	8.50		6.5"	9	7.50"	#4 10"
10.25	8.50		6.0"	10		
10.50	8.50		6.0"	10		
10.75	8.75		6.0"	11		
11.00	8.75		6.0"	11		
11.25	8.75		5.5"	12		
11.50	8.75		5.5"	12		
11.75	8.75		5.5"	12		
12.00	9.00	#6	5.5"	12		

DESIGN DATA

Live Load = HS 20  
fs = 24000 psi  
fc = 1800 psi  
n = 8  
Dead load includes  
48 psf for 4" HBP

CONCRETE SLAB DESIGN DATA  
LOAD FACTOR DESIGN

Effective Span S(ft.)	Top Slab Thick. T (in.)	Top Slab Reinf. Size Spa.	"D" Bars No. of #5 Bars	Bot. Slab Thickness TB (in.)	Bot. Slab Reinf. Size Spa.		
3.50	8.00	#5	9.0"	3	5.50"	#4	14"
3.75	8.00		9.0"	3			
4.00	8.00		9.0"	3			
4.25	8.00		8.5"	3			
4.50	8.00		8.5"	3			
4.75	8.00		8.0"	4			
5.00	8.00		8.0"	4			
5.25	8.00		8.0"	4			
5.50	8.00		8.0"	4			
5.75	8.00		7.5"	4			
6.00	8.00		7.5"	4			
6.25	8.00		7.0"	5			
6.50	8.00		7.0"	5			
6.75	8.00		6.5"	5			
7.00	8.00		6.5"	5			
7.25	8.00		6.0"	6	5.50"		
7.50	8.00		6.0"	6	5.75"		14"
7.75	8.00		6.0"	6	6.00"		13"
8.00	8.00		6.0"	6	6.00"		13"
8.25	8.00		6.0"	6	6.25"		12"
8.50	8.00		5.5"	7	6.50"		12"
8.75	8.00		5.5"	7	6.75"		11"
9.00	8.00		5.5"	7	6.75"		11"
9.25	8.25		5.5"	7	7.00"		11"
9.50	8.25		5.5"	7	7.25"		11"
9.75	8.25		5.0"	8	7.50"		1
10.00	8.25		5.0"	8	7.50"	#4	10" 0 "
10.25	8.50		5.0"	9			
10.50	8.50		5.0"	9			
10.75	8.75		5.0"	9	DESIGN DATA		
11.00	8.75		5.0"	10			
11.25	8.75		5.0"	10	Live Load = HS 20		
11.50	8.75		5.0"	10	fy = 60000 psi		
					f'c = 4500 psi		
11.75	9.00		5.0"	11	Dead Load Includes		
12.00	9.00	#5	5.0"	11	48 psf for 4" HBP		

See Bridge Rail details for curb reinf.

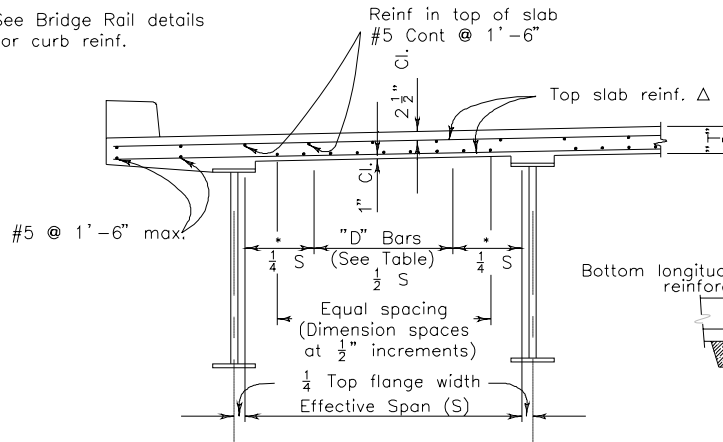

STEEL GIRDER

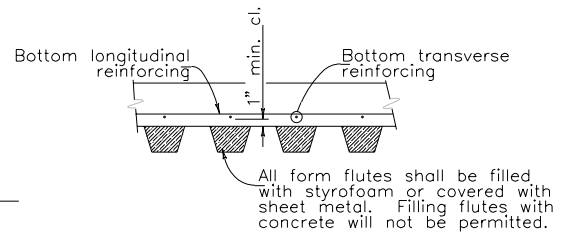

PERMANENT STEEL DECK FORM  
DETAIL

See Bridge Rail details for curb reinf.

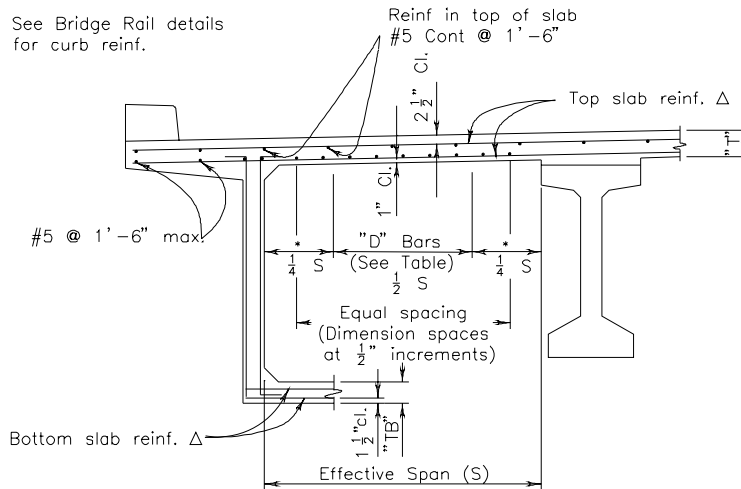

CONCRETE GIRDER

- \* Add 1 "D" bar at each  $\frac{1}{4} S$  for  $S = 3'-6"$  thru  $6'-6"$
- Add 2 "D" bars at each  $\frac{1}{4} S$  for  $S = 6'-9"$  thru  $10'-3"$
- Add 3 "D" bars at each  $\frac{1}{4} S$  for  $S = 10'-6"$  thru  $12'-0"$

Δ For curved structures place radially and space along  $\phi$  between edges of deck. When the difference in spacing between the outside edge of deck and the  $\phi$  between edges of deck becomes greater than  $\frac{1}{4}$  inch, place bars parallel.

For skews  $20^\circ$  or less place parallel to abutments and piers and space along  $\phi$  of structure.

For skews greater than  $20^\circ$  place perpendicular

CONCRETE DECKS FOR DOUBLE TEES AND PRECAST BOX GIRDERS

**COMPOSITE DOUBLE TEES AND PRECAST BOX GIRDERS**

Slabs comprised of cast-in-place concrete on top of precast elements may be considered to act as composite for live loads and additional dead loads (HBP, rails, etc.) provided the following criteria are met.

1. The overall thickness of the laminated slab shall be at least the minimum stipulated by the slab design charts in Subsection 8.2 for the effective span used for design. However, the minimum thickness of the cast-in-place concrete portion of deck shall be 4-3/4 inches.
2. The top surface of the precast element at the cast-in-place/precast concrete interface shall be roughened by approved methods. This interface shall be clean and free of laitance at the time of placing the cast-in-place concrete.

The precast flange or top slab shall be designed to support self weight, construction load, and the weight of the cast-in-place slab concrete.

**NONCOMPOSITE DOUBLE TEES AND PRECAST BOX GIRDERS**

The design of noncomposite double tee and precast box girder bridge slabs shall be based on the following criteria.

1. Use allowable stress design with  $f_c = 0.4f'_c \leq 2.4$  ksi and  $f_s = 24$  ksi.
2. Consider the slab simply supported with an effective span for positive moment analysis. The magnitude of the LL moment is to be determined in accordance with AASHTO 3.24.3, including impact, and for double tees, omitting the continuity factor.
3. Double Tees - For negative LL moment, consider a simple cantilever with an effective overhang length of L. The magnitude of this moment shall be:  $(1/(2E))(L)(P20)(1+I)$  if  $L \leq 1'-8"$  or:  $(1/E)(L-0.833')(P20)(1+I)$  if  $L > 1'-8"$ .
4. The minimum slab thickness shall be  $(1/2)(b)$  or 8 inches, whichever is greater.
5. Provide positive distribution steel in accordance with Section 8-2 and the slab design charts.
6. The longitudinal reinforcing in the top of the slab shall be continuous #5's at a maximum spacing of 1'-6" for simple spans.
7. For bridge slabs precast with the girder, provide 2-1/2" clear cover for top steel and 1" clear for bottom steel.

*Definition of Variables:*

- S = effective simple span length of slab between common stems of double tee.
- b = double tee stem thickness at bottom of slab (neglect fillets).
- L = effective cantilever overhang of double tee defined as: clear cantilever overhang, neglecting fillet, plus  $(1/4)(b)$ .
- E = longitudinal width of slab over which a wheel load is distributed =  $(0.8X + 3.75)$ .
- X = L if  $L \leq 1'-8"$  or,  
=  $(L - 0.8333')$  if  $L > 1'-8"$ .
- P20 = load due to one rear wheel of an HS 20 truck.
- I = fractional part of impact factor.

---

GIRDERS

---

**GENERAL**

1. Live load deflections shall be limited to 1/800 of the span maximum or limited to 1/1000 of the span maximum for bridges with walks.
2. Intermediate diaphragms, when required, shall be placed perpendicular to the girders (or radially with curved girders).
3. Maximum shear stirrup spacing shall be 1'-6".
4. For (+) M in T-beams and box girders, the size of flexure steel required for positive moment at the most highly stressed section shall be determined and this size bar shall be used at every section to facilitate detailing and construction.
5. For (-) M in the top slab of T-beams or box girders, consider only the bars in the top of the top slab within the effective flange width as flexural reinforcement for (-) M. The longitudinal slab distribution bars in the bottom of the top slab shall not be considered to resist (-) M.

*CAST IN PLACE CONCRETE BOX GIRDERS*

1. Except in unusual cases, the bottom slab should be made parallel to the top slab.
2. Design shall include the additional dead load for deck formwork to be left in place. This formwork load shall be applied over a width equal to exterior web to exterior web.
3. Bottom slab drains shall be located in the low points of each cell.
4. Box girders with an inside depth of 5 feet or greater shall be made fully accessible for interior inspection. Access to each cell shall be provided by bottom slab access doors, interior web openings, or diaphragm openings. Where solid pier diaphragms are used, each span will require access doors. Bridge Standard B-618-2 shows typical bottom slab access door details. Refer to Subsection 2.7, Access for Inspection, for additional information.
5. Configuration of shear stirrups shall be according to Bridge Standards B-618-1 and B-618-2. Stirrup hooks shall extend into the lower plane of the bottom slab steel and between the upper and lower planes of top slab steel and shall be developed in accordance with AASHTO 8.27.
6. One-piece "U" stirrups shall not be used in box webs.

---

PIER CAP REINFORCING DETAILS

---

Preferred reinforcement configuration for pier caps and integral pier caps shall be as follows.

*INTEGRAL PIER CAPS FOR CAST-IN-PLACE GIRDERS*

1. Cap reinforcement shall be placed below both mats of slab steel and below the main girder reinforcement in mild reinforced T-beams and boxes. In post-tensioned T-beams and boxes, the cap reinforcement shall be placed below both mats of slab steel or between the mats of slab steel, if necessary, to provide clearance for P/T ducts.
2. Hooks on integral cap shear stirrups shall be bent away from the centerline of the cap. The hooks shall enclose a cap reinforcement bar and the stirrups shall be developed according to AASHTO 8.27.2. To insure proper concrete cover for stirrup hooks, hooks shall be below the top mat of slab steel.
3. Maximum spacing of shear stirrups shall be 1'-6".
4. See Figure 8.5.1 and 8.5.2 for details.

*PIER CAPS FOR STEEL AND PRECAST GIRDERS*

1. Cap reinforcement shall be enclosed in closed stirrups, as shown in Figure 8.5.3 and 8.5.4. Stirrups shall be developed according to AASHTO 8.27.2.
2. Maximum spacing of shear stirrups shall be 1'-6".

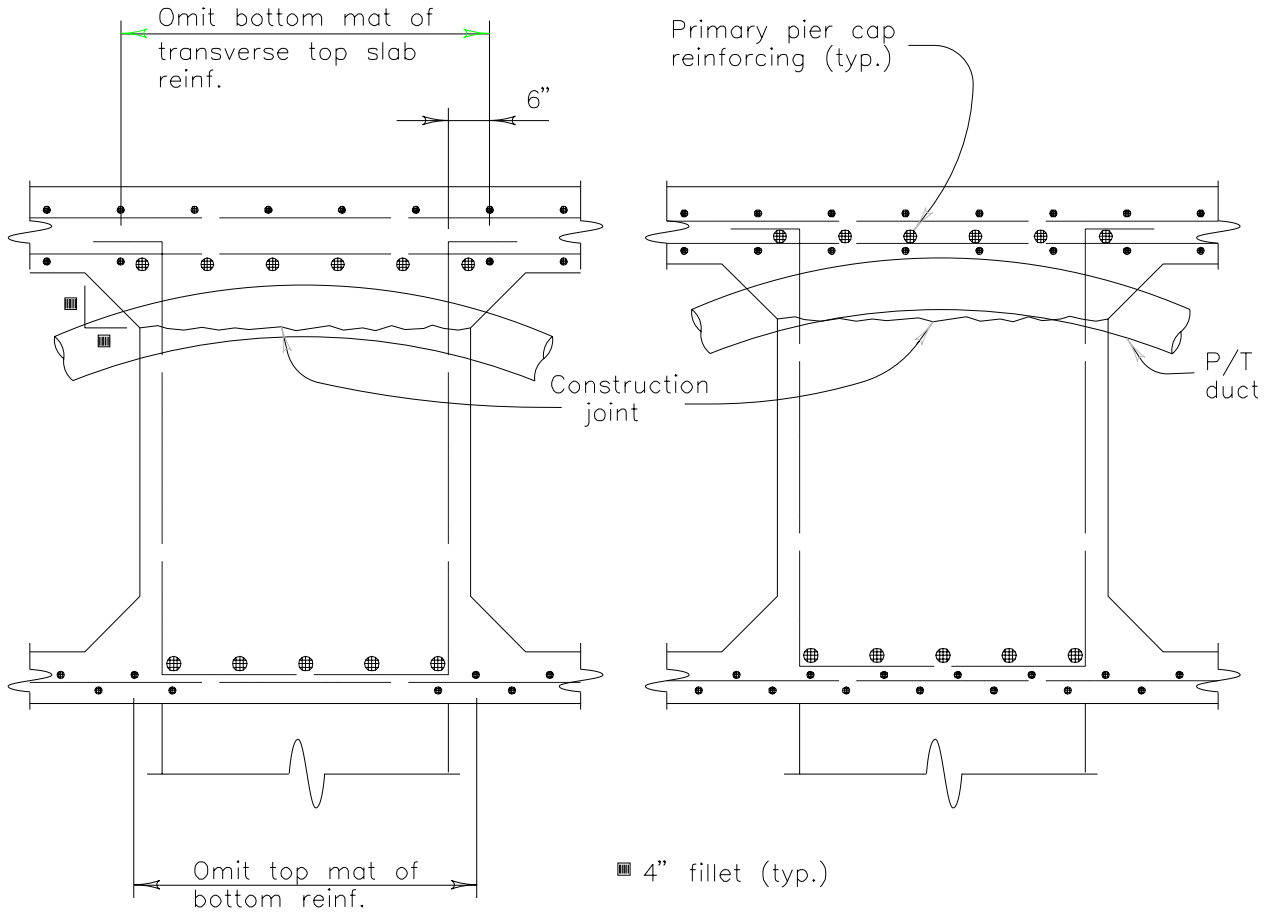

Note: Side face steel not shown.

Skew = 20° or less  
Deck reinforcing  
parallel to cap.

Skew > 20°  
Deck reinforcing  
not parallel to cap.

FIGURE 8.5.1

FIGURE 8.5.2



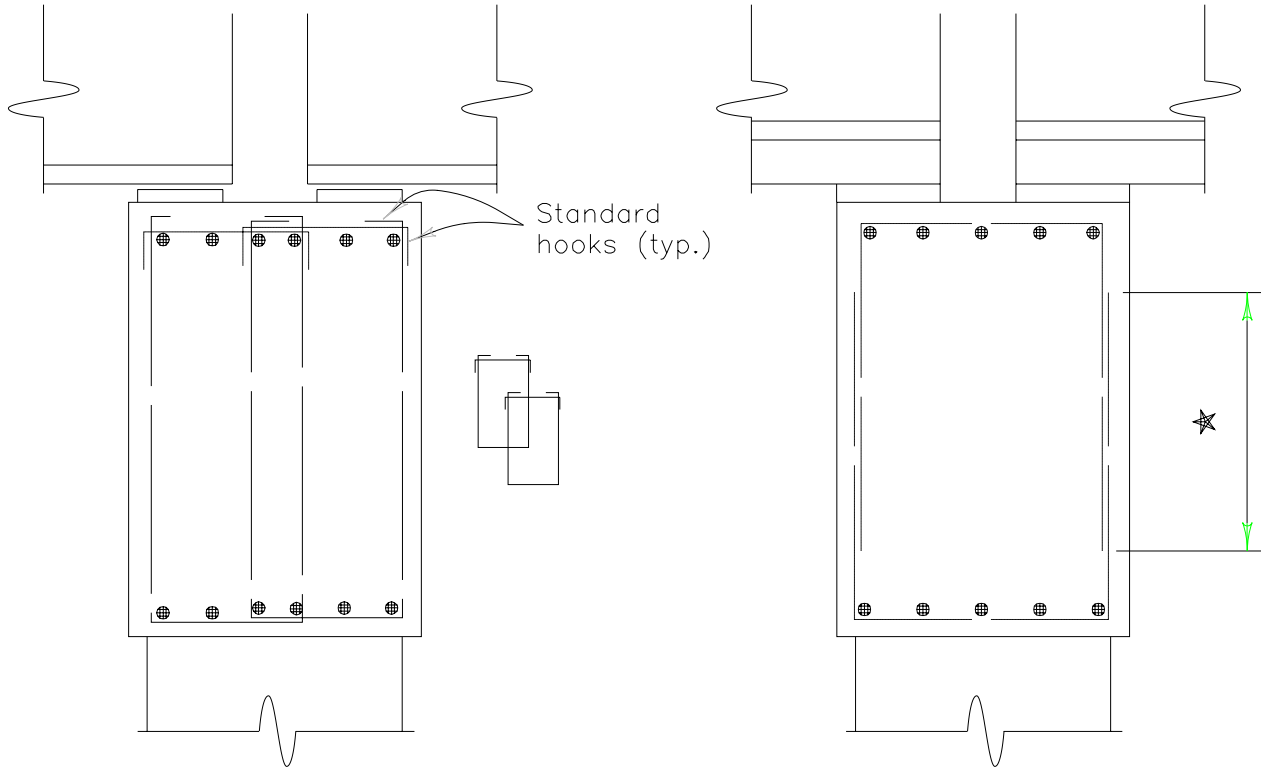

★ Minimum splice = 1.7L<sub>d</sub>  
Class C splice

Note: Side face steel not shown.

Constant depth cap.

Variable depth cap.

FIGURE 8.5.3

FIGURE 8.5.4

SPIRALS FOR ROUND COLUMNS

POLICY

COMMENTARY

Spiral reinforcement should be included in the plans as an option to the more traditional stirrup ties normally used. This option shall be provided by a note on the plans; i.e., #4 column stirrups shown, substitution shall be at the Contractor's option and expense.

This Subsection, 8.6, is taken directly from the Staff Bridge Engineer's 5/22/90 Policy Letter Number 3.

The potential benefits from the use of spiral reinforcement in round columns are such that the use of spirals should be permitted.

To establish consistent pitch and size, the following shall be used:

COLUMN DIA.	CONCRETE STRENGTH f'c, psi				
	3000	4000	4500	5000	6000
24"	#4	#4	#5	#5	#5
30"	#4	#4	#5	#5	#5
36"	#4	#4	#5	#5	#5
42"	#4	#4	#4	#5	#5
48"	#4	#4	#4	#4	#5
pitch = 3" for all of the above					

The above assumes a 2" clearance on columns. Where a greater cover is provided for conditions other than loading (caissons or example), the reinforcement requirements of AASHTO 8.18.2 are waived, as provided for in 8.18.2.1, and the above criteria shall prevail. For conditions other than described above, individual calculations should be made.

COLORADO DEPARTMENT OF TRANSPORTATION STAFF BRIDGE BRIDGE DESIGN MANUAL	Subsection: 9.1 Effective: August 1, 2002 Supersedes: June 1, 1998
DESIGN OF PRESTRESSED BRIDGES	
POLICY	COMMENTARY

**9.1.1 GENERAL**

Live load deflections shall be less than 1/800 of the span, or less than 1/1000 of the span for bridges with pedestrians. (C1)

Refer to Subsection 8.2 for deck overhang limitations.

Fully bonded internal prestressing shall be used for at least the portion of the prestressing steel needed for ultimate strength. (C2)

Partial prestressing may be used for repairs or upgrades to existing structures. The criteria for strength and allowable compression stress in Section 9 of the AASHTO Standard Specifications shall apply to partially prestressed members. The allowable tension stresses in Section 9 may be waived in lieu of the crack control provisions in Section 8 (under Serviceability Requirements, Distribution of Flexural Reinforcement). (C3)

If strand is used, the plans shall be based on the use of low-relaxation strand. (C4)

The design of curved T-beams with any horizontal curvature, and curved box girders with a radius less than 240 m (800 ft.), shall consider curvature effects such as torsion, lateral flange bending, duct blowout, lateral web bending, shear redistribution from skew (since skew can combine adversely with curvature effects), and increased load distribution to the outside webs. Any diaphragm requirements due to curvature shall also be considered. (C5)

C1: AASHTO does not give deflection limits in the prestressed concrete chapter. The values given here are taken from the AASHTO chapters on structural steel and reinforced concrete.

C2: Fully bonded internal prestressing should be used whenever possible. Doing so improves overload behavior at operating levels for both flexure and shear, and improves crack control. However external post-tensioning and unbonded strands are occasionally needed. External post-tensioning is used for repairs and segmental girders. Unbonded strands are used for temporary tensioning, to provide for future post-tensioning, and to control stresses in pretensioned members by means of sleeving. This policy provides a limit for such practices.

C3: Adding prestressing to existing structures can improve serviceability and reduce cracking. This policy allows such tensioning which may otherwise be prohibited due to a lack of code provisions for partial prestressing.

C4: There has been insufficient use of stress-relieved strand to justify continuing our previous policy of allowing the Contractor the option of either stress-relieved or low-lax strand. Low-lax strand will normally be slightly more efficient to use and have more predictable deflections.

C5: The CDOT Staff Bridge Worksheets for box girders (618-1

August 1, 2002	Subsection No. 9.1	Page 2 of 11

Curved webs with any horizontal curvature shall have cross ties at each level of ducts, a minimum of #10M at 350 mm (#3 at 14"). (C6)

Maximum stirrup spacing shall be 450 mm (18"). Minimum shear steel shall be at least  $A_v = 0.93(b')/f_y$  (square mm per mm), where  $b'$  is the web width in mm and  $f_y$  the reinforcement yield strength in MPa  $\{=135(b')/f_y$  (square inches per inch) where  $b'$  is web width in inches and  $f_y$  is in psi}. Webs for a distance  $d$  in front of anchorages and integral caps shall have at least double this minimum reinforcement. (C7)

The minimum side face steel located in webs shall be 1.5 times the above minimum shear steel area specified for areas more than distance  $d$  from supports, and spaced at 300 mm (12") maximum. This steel shall be used throughout the length of cast-in-place members (including cast-in-place segmental), and shall be located in at least the end portion of precast members. (C8)

through 618-3) were checked for curvature problems at radii greater than or equal to 240 mm (800 ft.) with a jacking force no greater than 5280 kN (1187 kips) per duct.

Curved T-girders may present web lateral bending problems at ultimate strength.

C6: These cross ties help arrest "unzipping" if duct lateral blowout is initiated by a construction flaw. Normally tendons should not be curved so sharply that the concrete alone cannot resist the blowout forces at ultimate tendon strength using the ultimate concrete tensile strength or punching shear strength.

C7: This minimum stirrup reinforcing matches our historical practice in Colorado. It provides stirrups that are adequate as temperature and shrinkage steel. It helps control the size of shear cracks, because this amount of reinforcing ensures that the member's cracked shear strength is greater than the shear necessary to crack the section. This minimum also overcomes uncertainty about adequacy of AASHTO's 0.345 MPa (50 psi) requirement with high strength concrete. The occasional need to control bursting forces which extend ahead of the typical anchorage block or abutment indicates a need for more stirrups ahead of anchorages. The lack of support induced vertical compression may induce a similar need at integral caps. We have had a few bridges with poorly controlled horizontal cracks in webs ahead of anchorages to indicate this problem.

C8: This provides distributed horizontal steel to help control cracks, which may include the nearly vertical shear cracks which occur near member ends, temperature or shrinkage cracks, cracks due to formwork or shoring settling, or flexural cracks at overload.

Note, Colorado allows trucks that weigh up to 91 Metric Tons (200 kips) to use bridges on a routine basis, if the bridges have an adequate operating capacity. Though usually much less for actual load

August 1, 2002	Subsection No. 9.1	Page 3 of 11

The negative moment zones of continuous bridges shall be designed for shear by the latest AASHTO method and not by the method given by the 1979 Interim of the AASHTO Standard Specifications. (C9)

The contract plans for post-tensioned members shall specify:

- jacking force
- area of prestressing steel
- minimum concrete strength at jacking and at 28 days
- center of gravity of prestressing force path
- jacking ends
- anchor sets
- friction constants
- long term losses assumed in the design
- strand and duct size assumed in the design
- net long term deflections and expected cambers (C10)

The contract plan for pretensioned members shall specify:

- jacking force
- area of prestressing steel
- minimum concrete strength at jacking and at 28 days
- center of gravity of prestressing force path
- final force at the critical section
- net long term deflections and expected cambers (C10)

The design shall be based on a maximum jacking force of 75% of the ultimate strength of prestressing strands. (C11)

All mild steel shall have at least 50 mm (2") clear between parallel bars, including spirals. (C12)

distributions, the calculated load may be up to 77% of the bridge members' ultimate strength. Normal code provisions may not adequately control flexural and shear cracking for routine excursions to these stress levels over the design life of the bridge.

C9: The 1979 interim methodology assumes simple span behavior. This may be unconservative for our precast girder bridges made continuous by integral pier diaphragms. Continuity can result in greater shears at continuous supports than is predicted by simple span analysis; and, large bending moments. The flexure cracks from these bending moments may propagate into the web under overloads, reducing the shear capacity.

Most often, however, the 1979 Interim methodology results in much more shear reinforcing than is required by the current AASHTO specifications.

C10: This policy provides a standard and consistent method for detailing prestressing. It also provides maximum flexibility to contractors and fabricators. In unusually difficult situations, the data for each tendon may need to be specified.

C11: This limit provides a margin for the correction of field problems, increased safety, and reduced strand breakage.

C12: This provides access for a vibrator. The segmental bridges at Vail Pass had problems with concrete consolidation at tendon anchorage's when this requirement was not met. Suppliers often specify spirals with a pitch, which will not meet this requirement. Consequently, shop drawings need to be checked for this clearance.

August 1, 2002	Subsection No. 9.1	Page 4 of 11

Immediately after tensioning, extreme fiber tension shall be less than 1.4 MPa (200 psi); except, portions of the extreme fiber that are not subject to tension under full service load (after all losses have occurred), or are not intended to be prestressed, may have tension up to  $0.62\sqrt{f'_{ci}}$  MPa ( $7.5\sqrt{f'_{ci}}$  psi) if well distributed steel is present to carry the tension. (C13)

Under full dead load, without live load and after all losses, no part of the top or bottom fiber which resists moments using prestressing shall be in tension. (C14)

Under full loads, after losses, tension due to live load will be permitted in the extreme fibers of prestressed parts of members if well bonded well distributed steel (prestressing included) is provided to carry the tension. (C15)

If any part of the top of a deck resists moments using prestressing, the tension in that part shall not exceed  $0.25\sqrt{f'_{ci}}$  MPa ( $3\sqrt{f'_{ci}}$  psi). (C16)

#### 9.1.2 CAST-IN-PLACE OR POST-TENSIONED

The  $f'_{c}$  shall be at least 30 MPa (4500 psi) when any part of the prestressed member forms any part of the deck. For cast-in-place members the required  $f'_{c}$  shall not be greater than 40 MPa (5800 psi). The required  $f'_{c}$  shown in the plans shall be equal to or greater than the  $f'_{ci}$  required. Either concrete Class D (30 MPa {4500 psi}), Class S35 (35 MPa {5000 psi}) or Class S40 (40 MPa {5800 psi}) shall be used, listed here in order of preference. (C17)

C13: These limits are from the AASHTO Standard Specifications. They help prevent cracking and distress from tensioning stresses.

C14: This ensures that live load cracks caused by overloads will close.

C15: In contrast to no tension being allowed under final dead load, live load tension is allowed to economize designs. It is not our intent to apply compression or tension limits to mild reinforced decks that are not pretensioned or post-tensioned.

C16: This provides for less deck cracking and presumably less deterioration from salt intrusion. This provision is intended for portions of decks that are pretensioned or post-tensioned.

C17: For cast-in-place concrete 6000 psi maximum has been the Department's standard practice. This has been hard converted to 5800 psi for the Department's migration to using metric units. There is typically less variation in the quality of concrete at lower strength, and lower strength concrete can be more economical, consequently Class D should be assumed initially for design. If greater strength is needed, then Class S35 should be tried, or as last preference, Class S40. In 1997 Staff Bridge with Staff Materials decided to regulate cast-in-place superstructure concrete to only three different strengths to help reduce the variations in mix designs that the Department was receiving. If the need arises, we may develop higher strength classes in the future. If higher strength is needed for a project, the Staff Bridge Engineer shall be consulted.

August 1, 2002	Subsection No. 9.1	Page 5 of 11

The plans shall show the configuration (arrangement) of the anchorage's, and the arrangement of ducts at typical high and low points which are appropriate for the duct and strand size noted on the plans. The arrangement of anchorages shall permit a center to center anchorage spacing of at least  $\sqrt{(2.2(P_j)/(f'_{ci}))}$  meters (inches), and a spacing from the center of each anchorage to the nearest concrete edge of at least half that value. If web flares are needed for this arrangement, they shall be dimensioned in the plans and included in the quantities. (C18)

The post-tensioning arrangement provided by the plans shall permit the use of either 13 mm (0.5") or 15 mm (0.6") strands. (C19)

The design shall not require the use of more than 5280 kN (1187 kips) of jacking force per duct. (C20)

Ducts shall be spaced at least 44% of the duct diameter or 38 mm (1.5") minimum clear from each other, whichever is greater. (C21)

Cast-in-place webs shall have a clear space between ducts and formwork, and between longitudinal rebar and formwork, of at least 75% of the nominal duct diameter, but not less than 75 mm (3") to facilitate concrete placement and vibrator use. At least 50 mm (2") clear should be provided between post-tensioning ducts and the outside face of precast girder webs. (C22)

C18: This requires the designer to provide a practical solution to arranging the post-tensioning in the contract plans. The designer's solution should not require a strand steel area greater than 40% of the duct inside cross section area for bundles of strands. 33% to 37% duct fill is typical. More area may be required for long ducts of the smaller diameters (under 3.5"). The combination of maximum jacking force per duct (at 75% of ultimate) and duct size should be one provided for in the current literature of one of our common suppliers of post-tensioning components, such as DSI or VSL. Alternative arrangements may be proposed by the supplier on the shop drawings.

C19: This improves competition.

C20: This maximum improves competition and it is consistent with established practice. Previously this limit was 3716 kN (835 kips). The current limit of 5280 kN (1187 kips) is reflected in CDOT Staff bridge Worksheets 618-1 through 618-6. The designer can approve shop plans with a somewhat higher jacking force per duct if it does not cause any problems. Note, the 30" thickness of CDOT's typical integral abutment is marginal for containing the bursting forces and spirals needed for this maximum jacking force.

C21: This facilitates concrete placement and helps prevent problems in curved area. The increase for 4" and larger ducts is due to recent consolidation problems with larger duct diameters.

C22: This facilitates concrete placement, vibrator access, and reduces weakened plane cracking in thin webs.

August 1, 2002	Subsection No. 9.1	Page 6 of 11

Cast-in-place concrete superstructures shall be considered during the structure selection report process. T-girders, spread box girders, full width box girders, and slabs should be investigated. The investigation should be made with structure depth, web size and web spacing optimized for each type of superstructure. (C23)

**9.1.3 PRECAST OR PRETENSIONED**

The f'ci for precast girders shall generally be limited to 45 MPa (6500 psi) and f'c to 60 MPa (8500 psi). These limits may be increased by up to 7 MPa (1000 psi) if the feasibility of efficient production (i.e., no net increase in costs) for the particular project with these strengths has been confirmed with our usual fabricators. The f'c shall not be less than 30 MPa (4500 psi). The required f'c shown in the plans, shall be equal to or greater than the f'ci required. (C24)

C23: T-girders may be less expensive than boxes in situations where the strength contribution of the bottom slab does not outweigh its cost and dead load.

The minimum web width is 250 mm (10") for 100 mm (4") diameter ducts and 290 mm (11.25") for 115 mm (4.5") ducts. These minimum widths should be used for short span situations that do not require large girder depths, large quantities of tensioning (i.e., more than two ducts per web), nor close web spacing. Otherwise 380 mm (15") wide webs should be used to allow placement of two ducts per row (staggered) and easy concrete placement.

Very long span cast-in-place box section may be an exception when the desired prestress eccentricity at mid-span for final loads cannot be used due to mid-span negative moments that occur during the deck pour. In this case 250 mm (10") webs may help control dead weight; however, 380 mm (15") may still be effective at piers where the shears are high and larger prestress eccentricity can be used.

Webs should normally be placed as far apart as practical to minimize web concrete and, especially, formwork costs, though deck costs must also be considered. 3600 mm (12') clear spacing between webs should not be considered exceptional.

C24: Previously the f'c limit for precast concrete was 54 MPa (7500 psi). This was changed to 60 MPa (8500 psi) to meet the current capability of our precast suppliers. Recent changes (1996) to the AASHTO code allowing higher service compressive stresses will typically make increasing the f'c limit unnecessary.

The higher liveload (HL93) in LRFD may make values of f'c greater than 8500 psi useful for some LRFD designs, especially with the new U girder sections which have a variable width top flange that can



August 1, 2002	Subsection No. 9.1	Page 7 of 11

Using lump sum losses for precast pre-tensioned girders is discouraged. If lump sum losses are used for precast pre-tensioned members, the tension in the extreme fiber shall be limited to  $0.25\sqrt{f'c}$  MPa ( $3\sqrt{f'c}$  psi). (C25)

End blocks shall be used for box girders. End blocks are not required for typical applications of the Colorado BT-girders using the CDOT Staff Bridge Worksheet details. (C26)

Composite precast pre-tensioned girders spliced at pier diaphragms shall typically be designed as simple spans, with reinforcing provided for the positive and negative moments resulting from continuity at and near the piers. Alternatively, this and other arrangements of spliced girders may be designed taking continuity into account if the necessary additional design considerations are conducted. When utilizing continuity for the girder design, the effects of differential shrinkage, differential temperature, and any redistribution of moments due to creep shall be investigated.

The design of precast girders should not be made dependent on continuity, or require post-tensioning, unless doing so significantly reduces the cost of the structure. For simple spans made continuous the beneficial effects of continuity on girder design should not be used unless the number of girder lines is reduced. (C27)

be adjusted to reduce weight if higher strength concretes are used.

The  $f'ci$  affects economy by dictating how long girders must remain in the casting beds. Due to improvements in fabrication practices and technology, using  $f'ci$  of 50 MPa (7000 psi) is probably practical now for limited production, and 45 MPa (6500 psi) for routine production, except in very cold weather or for large numbers of precast box girders which may need a more fluid mix than those mixes which provide the highest early strengths.

C25: We seldom use lump sum losses for precast members. Detailed losses for the sections we normally deal with indicate that the use of lump sum losses can be unconservative. The reduced allowable stress given here helps correct this.

C26: Without end blocks, the previously used Colorado G-girder sections may have had inadequate shear, bursting, and handling strengths. Our BT-girder sections have thicker webs and bar details for the associated problems and therefore do not require end blocks for ordinary usage. Adding post-tensioning anchorage's to the BT-girder is an instance where end blocks may be useful.

C27: Previously all precast pre-tensioned girders were required to be designed as simple spans. This was due to the accuracy of commonly used methods for determining the concrete stresses resulting from the primary and secondary effects of shrinkage, temperature, temperature differentials, and creep. Due to the information now available to address these issues, and to take advantage of the economy offered by continuity, in 1993 the Department began to allow continuity to be used as approved on a case-by-case basis. In 2002, this policy is further liberalized, however it is important that designers not make their design dependent on continuity, or on post-

August 1, 2002	Subsection No. 9.1	Page 8 of 11

Post-tensioning may be used with precast girders provided the staged and long term effects of the tensioning are adequately accounted for in the design. Post-tensioning may be used to optimize the design of long span girders, to facilitate splicing girders, or to optimize the fabrication process. Fabricators may be allowed the option of providing a part of intended pre-tensioning with post-tensioning. (C28)

Girder haunches shall be sized so no design changes or deck rebar shifts will be needed if the predicted camber plus the girder depth given in the plans is exceeded by 38 mm (1.5") before the deck pour. (C29)

tensioning, unless there is a significant benefit in costs.

Note, In April 2002 CDOT's policy was changed to use continuity for the rating of all precast girders, regardless of the method of design, to provide uniformity in the inventory for the operating rating for moment of these girders.

C28: Post-tensioning has been used in combination with pre-tensioning for splicing long span BT-girders and for providing the necessary tensioning when the jacking force exceeds fabricator bed capacity. The latter may be necessary to use the new BT sections efficiently, as up to 10000 kN (2250 K) of jacking force is needed to fully utilize the concrete capacity provided by these sections. However, our usual fabricators have taken steps to improve their jacking capacities to well beyond 10,000 kN (2250 K). Allowing post-tensioning to be substituted for intended pre-tensioning should be avoided if the fabricator has the ability to provide the necessary jacking forces with pre-tensioned steel only. Economics favor using pre-tensioning instead of post-tensioning, and as few post-tensioning stages as practical.

C29: The 38 mm (1.5") required here has typically been enough tolerance to cover the unreliability of camber predictions and girder depth variations. However, as we extend our span length capability, or use shallower sections or new suppliers, more tolerance or better predictions may be needed. For additional information on camber and fabrication tolerances see PCI MNL-116. PCI MNL-116 allows +25 mm (+1") camber tolerance for typical depth/span ratios, and +13 mm (+0.5") girder depth tolerance.

Most of our inadequate haunch depth problems have been due to long delays between girder fabrication

August 1, 2002	Subsection No. 9.1	Page 9 of 11

It is the designer's responsibility to verify the constants used for camber prediction by the girder design software. A sensitivity analysis is recommended, and adjustment of the constants is required, as necessary to ensure camber predictions are within the 1.5" tolerance provided in the haunch calculations. (C30)

The average minimum haunch depth due to cross-slope plus the minimum haunch due to precast deck panels (25 mm {1"}) may be used for section properties. A weighted average haunch depth may be used for dead load calculations. The weighted average haunch shall be based on a girder camber no larger than the value shown in the plans. All other dimensions (haunch depth at the ends of girders, dead load deflection, and deck geometry) shall be from values shown in the plans. (C31)

and deck placement, and inadequate allowance for deck geometry. The 38 mm (1.5") should not be relied on to solve these problems. Long delays are addressed by a note in the plans alerting contractors to monitor camber growth, and deck geometry must be addressed during design as part of the girder haunch depth calculations.

Note that camber is sensitive to the prestressing path and may be controlled to a degree by adjustments to the path during design.

C30: CDOT's recent use of the conspan software for girder design has led to camber predictions that have not been tailored for local experience or practices. More recently, the use of Opis/Virtis software has been initiated. Designers need to become familiar with the methodology used by these applications for camber prediction and make the necessary adjustments to ensure the haunch depth and deflections used for design, and shown in the plans, is adequate.

C31: Previous practice had been to treat haunches conservatively by not using them for section properties and overestimating their dead load effect. This can be overly conservative when using BT-girders and precast deck panels, both of which result in significantly larger haunches than used in the past.

$(d1+10(d2)+d3)/12$  is a calculation for the weighted average haunch for dead load where the haunch depth at centerline of girder is  $d1$  over one bearing,  $d2$  at mid-span, and  $d3$  over the other bearing. In most situations this provides a suitably accurate result for mid-span moment. This equation is derived for the mid-span moment affect assuming the haunch varies parabolically with the apex (either concave or convex) at mid-span.

August 1, 2002	Subsection No. 9.1	Page 10 of 11

The transverse reinforcing steel area in precast box girder flanges shall, as a minimum, be equal to the minimum required shear reinforcing steel for one web. (C32)

Precast girder segment joints shall be bonded with epoxy or with concrete closure pours. (C33)

The G-series girders have been discontinued and should not be used except for replacement of damaged G1730 (G68) girders and resetting existing girders. The G1370 (G54), G1730 (G68) and G1830 (G72) have been replaced as the Department's standard sections by Bulb-T girders: BT1070 (BT42), BT1370 (BT54), BT1600 (BT63), BT1830 (BT72) and BT2130 (BT84).

It is the designer's responsibility to verify stability of the girders during construction, especially the stability of exterior girders. Additional diaphragms, or modifications to CDOT's standard diaphragm details (see worksheet B-618-DF) may be needed for special situations; e.g., unusually large overhangs. Additional diaphragms, or modifications to the standard details, should not be used unless determined necessary by calculation. (C34)

CDOT now requires the LRFD specifications to be used for new structures. Until confidence in the LRFD specifications and software applications is achieved, designers will compare the results of LRFD with LFD. Differences should be expected. It is not a requirement that structures meet the requirements of LFRD as well as LFD specifications. It should be expected that various aspects of LRFD will be more, and others less, conservative than LFD. When LFD seems to indicate that an LRFD design is not adequate, the designer should verify the cause of the difference to assure no mistakes have been made. (C35)

C32: This policy helps ensure that the torsional shear strength and strand confinement, which may be needed, is provided.

C33: This practice improves waterproofing, and improves overload behavior in both flexure and shear.

C34: The BT series of girders are heavier and provide wider flanges, improving their stability during the construction stages. The notes in the worksheet (B-618-DF) provide for those situations where diaphragms are needed for additional stability against wind loads during the construction stages if full flange width leveling pads are used. The girders have been checked for stability during the deck pour when they have typical reasonable overhangs.

Designers should check that the resultant of construction loads falls within the area of the leveling pad and that the compression in the pad is less than the allowable strength (typically >2250 psi ultimate). Reasonable safety factors should be used for this check; e.g., by using the AASHTO LRFD load factors when using the ultimate strength of the leveling pad.

If the resultant falls outside of the pad, or the compression strength of the pad is exceeded, additional diaphragms should be provided to reduce eccentricity by causing the girders to overturn in concert. Improved moment connections between the diaphragm and girder (by modifying the standard connection details or using deeper diaphragms or bracing) may also be used to provide moment resistance and thereby reduce the eccentricity on the pad directly.

C35: The following factors may be expected to cause some aspects of LRFD designs to seem less conservative than prior LFD designs:

The calibration for LRFD Service III tensile stresses is likely to have

August 1, 2002	Subsection No. 9.1	Page 11 of 11

LRFD exterior girder distribution factors are invariably larger for exterior girders than interior, reversing the typical situation under LFD. To balance exterior girder designs with interior girder designs, overhangs should generally be limited to less than half the interior girder spacing. (C36)

less effect than CDOT's recent conservative use of HS25 for this serviceability check. See the LRFD commentary on service III.

LRFD sometimes uses more rational distribution factors than before, often causing up to a 27% reduction of liveload wheel lines applied to an interior girder.

LRFD MCF shear in its newest version may be slightly less conservative than some prior shear practice, especially for highly shear reinforced prestressed sections, and negative moment composite areas.

The following factors may be expected to cause prior LFD practices or designs to be less conservative than LRFD:

The HL 93 load is heavier than HS 20 or HS 25. This may effect Service I compressive stresses and Strength I, which will also be effected by the higher load factor for overlays.

C36: A balance between exterior girder design and interior has been achieved in some instances with an overhang of about 1' less than half the girder spacing.

PRECAST PRESTRESSED CONCRETE COMPOSITE BRIDGE DECK PANELS

POLICY

COMMENTARY

The deck panel and cast in place slab act compositely to resist design loads. (C1)

Panel thickness less than 3 inches shall not be used. Deck panel thickness to maximum diameter of strand should be approximately 8:1. (C2)

<u>Panel Thickness</u> (in.)	<u>Maximum Strand</u> <u>Size(in.)</u>
3	3/8
3-1/2	7/16
4 or larger	1/2

Deck panel length may range from 2 ft to 10 ft but the most common lengths are 4 ft and 8 ft. Trapezoidal deck panels may be used at bridge ends on skewed bridges with skew limited to 20° or less.

Deck panel width will vary depending on girder type and spacing used. Panel length less than 2'-3" or greater than 12'-6" shall not be used.

The minimum concrete strength at stress transfer shall be 4500 psi and minimum 28 day compressive strength shall be 6000 psi.

Top surfaces of deck panels shall be roughened (parallel to strands) to ensure composite action between the Precast and cast in place slab.

Steel girders shall be designed so that the exterior rows of studs will not interfere with the deck panels.

The minimum amount of non-prestressed longitudinal steel required in the cast-in-place portion of slab shall be 0.20 sq in per ft of slab width. (C3)

C1: Precast prestressed concrete deck panels are alternative system to steel deck forms. Deck panels with cast in place concrete topping provide a cost effective and efficient method of construction for bridge decks.

C2: PCI journal special report March/April 1988.

C3: Regarding Article 9.18.2.2 of the AASHTO Standard Specifications, 0.25 sq in per ft has been chosen to correspond to an intermediate value used in Texas tests. Tests in Pennsylvania reported satisfactory results using #4 bars at 12 inch centers. Staff Bridge shall use the lower bound of these values.

COLORADO DEPARTMENT OF TRANSPORTATION STAFF BRIDGE BRANCH BRIDGE DESIGN MANUAL	Subsection: 9.3 Effective: June 1, 1998 Supersedes: New
--	---

---

PRECAST GIRDER DESIGN AIDS

---

The following table and graphs are design aids to help with the selection of girder types and spacing to speed the preliminary design process. The graphs are intended as relative cost, preliminary design, and review aids only, and should not be used in lieu of structural analysis.

The span capabilities shown may be limited by a maximum shipping weight of 85 tons per segment or site specific limitations. For the table, assumptions are no splices in simple spans, one splice in end spans and two splices in interior spans. Haunched pier segments were not assumed but may be feasible. Pier segments may require a thickened top flange and a thickened web. Economic spliced span capabilities were based on 4' clear between flanges.

Box sections may be provided in any required height up to about 78 inches, and any width up to 72 inches. The properties shown are for 6 inch webs, 6 inch bottom flange and 4 inch top flange. Actual box depths used on a project should optimize utilization of the available superstructure depth.

Design assumptions for the table and the graphs are the same, except the  $f'_{ci}$  in the table may be up to 8500 psi at the time of post-tensioning for spliced spans.

Note, the CDOT Staff Bridge Worksheets for precast girders have enough shear reinforcing steel for the loads, spans, and girder spacings covered by these design aids, except that widely spaced BT42, BT54, and, to a lesser extent, BT63 girders may require adjustments to the pre-tensioning path and quantity to satisfy shear requirements.

When designing spliced girders and utilizing continuity (i.e., using continuity for the prediction of dead loads and live loads, as applicable) the engineer must take into account differential creep, differential shrinkage, differential temperature, and any redistribution of moments due to a change in inflection point location from any construction stage to the final stage. A high degree of accuracy is not required, nor practical, for the prediction of concrete stresses if: well distributed bonded reinforcement is provided at both extreme fibers; the ultimate strength is adequate everywhere; and compression is assured under combined deadload, prestress, differential creep, differential shrinkage, and moment redistribution.

When designing spliced girders if the deflections are highly sensitive to the assumptions concerning concrete modulus, shrinkage, creep, construction timing and the balance between prestress and deadload deflections, then the spliced structural scheme being considered may be impractical. In this situation the uncontrollable deflection variations may exceed the desirable limits for vertical curvature or grade breaks for high speed traffic. Deflections should not be allowed to vary much more than  $L \cdot L / 10000$  metric,  $L \cdot L / 30000$  English, or  $L / 800$ , where L is the span length. Deflections should also not result in grade breaks in the deck of greater than 0.3%.

Both of our current precast suppliers can now accommodate large jacking forces with their box and BT girder beds. The BT girder cross section may accommodate up to 64 - 0.6" diameter strands at 2" spacing. For large amounts of strand in BT sections the EMS should be about 5.0". A somewhat

higher EMS may be needed to control stresses for railroad girders or widely spaced girders. The EE specified should normally be less than  $0.34 \cdot (h - 22 \cdot \text{EMS}) + \text{EMS}$  for BT girders (about 20" for a BT 72), where h is the girder depth.

June 1, 1998	Subsection 9.3	Page 2 of 5
--------------	----------------	-------------

The maximum number of 0.6" diameter strands precast box girders can accommodate in two rows is equal to approximately the total box girder width in inches, minus five. For large amounts of strand in box sections the EMS should be about 3.2". The EE specified should normally be less than  $0.21 \cdot (h - 5 - EMS) + EMS$  for box girders (about 9" for a 35" deep box). These EE calculations are based on the maximum number of strands in the section. Somewhat higher values of EE are possible if the sections do not have the maximum amount of strands.



PRECAST SECTION PROPERTIES							ECONOMIC SPAN CAPABILITIES			
APPROXIMATE							SIMPLE SPAN		SPLICED	
NAME	WIDTH IN	AREA IN <sup>2</sup>	CG IN	INERTIA IN <sup>4</sup>	EMS IN	EE IN	FROM FT	TO FT	END FT	INT FT
BT84	43	948	41.7	875207	5	22	120	172	200	240
BT72	43	864	35.8	594437	5	20	106	178	180	210
BT63	43	801	31.4	425875	5	18	90	162	160	190
BT54	43	738	27	289236	5	16	72	-143	140	170
BT42	43	654	21.1	153066	5	14	55	-114	114	130
BX44	72	1128	20.5	319160	3	~9	116	133	N/A	N/A
BX44	48	906	20.7	224630	3	~12	75	128	140	170
BX35	72	1038	16.1	177917	3	~7	95	-128	N/A	N/A
BX35	48	780	16.6	129108	3	~10	65	108	110	130
BX24	72	906	11.1	68313	3	~6	-79	-88	N/A	N/A
BX24	48	666	11.3	46880	3	~7	44	-79	N/A	N/A
BX18	72	834	8.4	31885	3	~5	-65	-71	N/A	N/A
BX18	48	594	8.5	21557	3	~6	36	-65	N/A	N/A
SL16	72	1152	8	24576	2.4	2.4	41	-47	N/A	N/A
SL14	72	1008	7	16464	2.4	2.4	36	-42	N/A	N/A
SL12	72	864	6	10368	1.9	1.9	31	-40	N/A	N/A
SL10	72	720	5	6000	1.8	1.8	25	-37	N/A	N/A
SL8	72	576	4	3072	1.8	1.8	24	-31	N/A	N/A
SL6	72	432	3	1296	1.7	1.7	14	-24	N/A	N/A
SL4	72	288	2	384	1.7	1.7	0	14	N/A	N/A

- Designates a span length which requires continuity to control live load deflection.

N/A Designates sections that typically cannot benefit from spliced design.

~ Designates typical EE if harping is used. Path may be harped and/or sleeved strands and/or bottom slab thickening used near supports to control stresses.

EMS and EE may vary due to design requirements and shop capabilities, representative values are shown.

DESIGN DATA AASHTO 1996:  
 HS25-44, Alternate, Permit live load  
 70 psf added, composite deadload  
 8" slab or #5 composite topping  
 $f_c = 6500$  psi max,  $f_c = 8500$  psi max.  
 Min. haunch used for parapetities  
 Weighted avg. haunch, for loads.  
 Jacking force not limited  
 Spread boxes are 48" wide.

KEY:  
 Numbers on lines are precast slab thickness or girder spacing as appropriate.  
 Designates section too heavy to ship.  
 Designates girders side by side.  
 < Shear governs.  
 (??) designates the ratio of stiffness provided to that needed for simple spans. About (.53) is needed for spans continuous at two ends and (.66) is needed for spans of continuous at one end.

Bridges carrying both pedestrians and traffic need 25% greater stiffness.  
 NOTE:  
 This chart may be valid for the positive moment areas of continuous spans if the span is taken as the maximum distance between points of inflection for combined deadload and live load. Merit is related to total cost, including one minimum cost substructure unit per span.

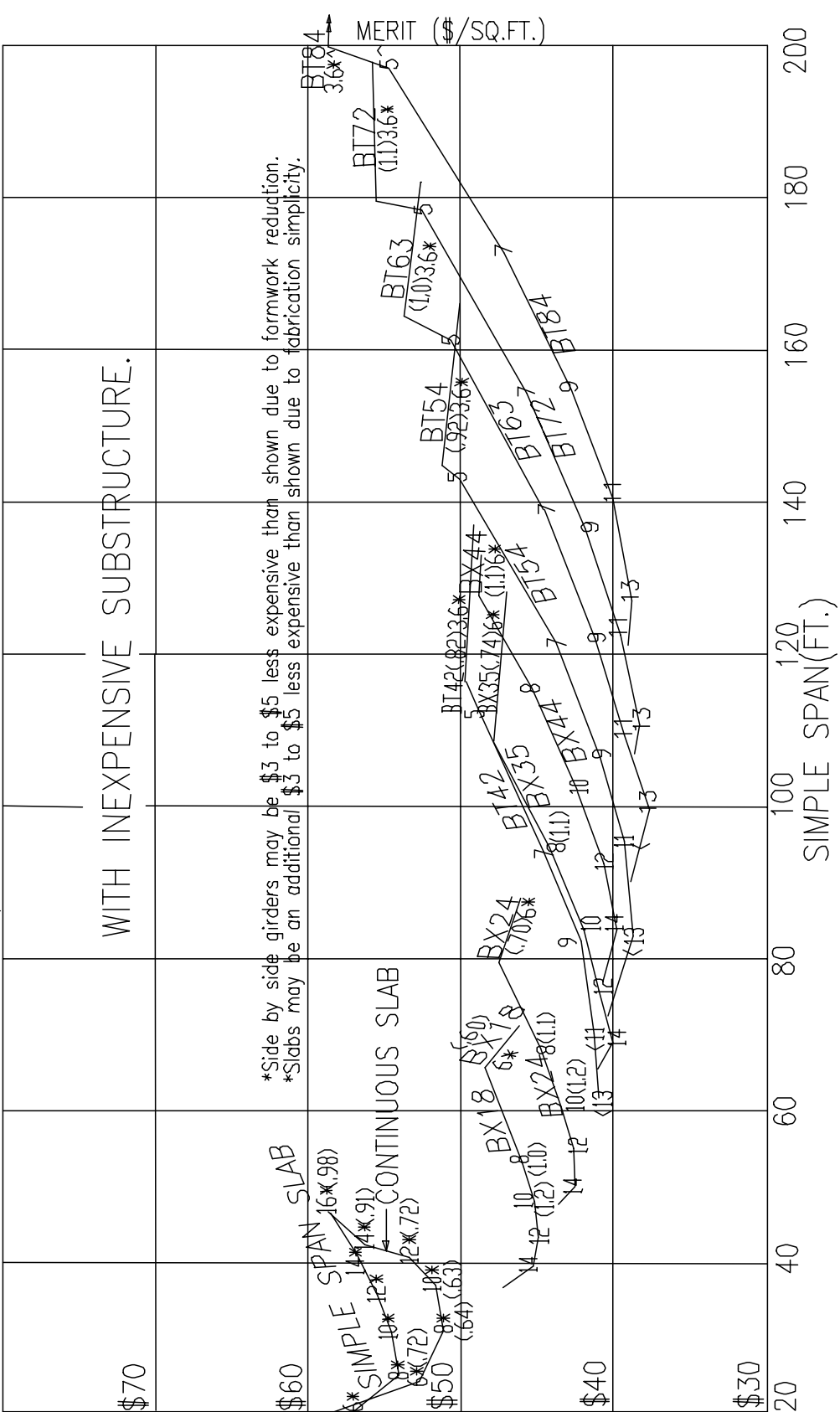

WITH INEXPENSIVE SUBSTRUCTURE.

\*Side by side girders may be \$3 to \$5 less expensive than shown due to formwork reduction.  
 \*Slabs may be an additional \$3 to \$5 less expensive than shown due to fabrication simplicity.

MERIT (\$/SQ.FT.)

SIMPLE SPAN(FT.)



COLORADO DEPARTMENT OF TRANSPORTATION STAFF BRIDGE BRANCH BRIDGE DESIGN MANUAL	Subsection: 10.1 Effective: November 5, 1991 Supersedes: January 25, 1988
--	---

DESIGN OF STEEL BRIDGES

POLICY	COMMENTARY
--------	------------

**10.1.1 GENERAL**

In addition to AASHTO Standard Specifications for Highway Bridges, with current interims, the following references are to be used when applicable for the design of steel highway bridges:

- AASHTO Guide Specification for Fracture Critical Non-redundant Steel Bridge Members.
- AASHTO Guide Specification for Horizontally Curved Highway Bridges.
- ANSI/AASHTO/AWS D1.5 Bridge Welding Code.
- AASHTO Standard Specifications for Seismic Design of Highway Bridges.

Structural steel railroad bridges shall be designed in accordance with the current AREA Specifications.

The 509 Special Provisions shall be reviewed by CDOT Staff Materials on jobs with Fracture Critical Members, jobs requiring unusual fabrication or materials, and on jobs utilizing existing structural steel. Additionally, on jobs utilizing existing steel, the District should be notified early in the project to determine if the existing paint contains hazardous materials and what associated Project Special Provisions will be required.

All girders shall be designed to be fully composite with the deck. Longitudinal reinforcing steel in the top mat, within the effective deck width, shall be used when calculating section

C1: Generally, the reinforcing steel stress limitation is an issue for shored girders. The 27 ksi was originally chosen to be consistent with the probable allowable tensile stress in the girder. It has been suggested that 24 ksi should be used to be consistent with the Working Stress Design reinforced concrete allowables. This could excessively penalize the maximum stress in grade 50 top flanges. Another suggestion was to use .55(60) ksi for grade 60 reinforcing steel.

Using reinforced concrete Load Factor Design criteria, the serviceability requirements control for common dead to live load ratios with a crack control allowable stress of 29 ksi (for #11's at 6" spacing and 2" cover -- note, a revision to 2" maximum cover for this calculation by AASHTO is anticipated) and an allowable fatigue stress range of 20 ksi. These results indicate that the 27 ksi should result in adequate strength, serviceability, and economy. Designers may use lower values where they feel necessary.

C2: In general, for primary and secondary members and member components, rolled shapes have lower fabrication costs and better fatigue characteristics than customized welded plate and bent plate members. Additionally, they generally do not require as much quality control inspection as fabricated shapes do. Consequently, where rolled shapes are otherwise sufficiently practical and economical, they are preferable to fabricated shapes.

November 5, 1991	Subsection No. 10.1	Page 2 of 12
POLICY		COMMENTARY

properties in negative moment regions. The stress in the deck reinforcing steel shall not exceed 27,000 psi. (C1)

Steel girders shall be made of rolled beams or welded plates. (C2)

Occasionally bent plates may be needed for attachments, connections, or secondary members. The AASHTO Standard Construction Specifications, and CDOT Standard Specifications, specify that plates may only be bent about an axis that is perpendicular to the direction of the plates' mill rolling. The designer shall consider the consequences of this requirement when using bent plates. (C3)

Uplift at supports and girder stresses due to the deck pouring sequence shall be considered during design. For additional requirements regarding bridge decks, see CDOT Bridge Design Manual Subsection 8.2.

#### 10.1.2 MATERIALS

Generally, ASTM A36 should be used for members and components where a higher yield strength steel would not appreciably reduce the required sections. ASTM A572 Grade 50 should generally be used for girder webs and flanges. ASTM A588 shall be used for weathering steel applications and shall be used in place of A572 for plates 3" and greater in thickness. Where A572 is used, the plans should allow A588 to be substituted for A572 at no additional cost to the project. (C4)

However, for girder members, welded shapes generally are the optimum solution for most of our steel girder applications.

C3: Bending plates parallel to the primary direction of rolling can introduce cracks along the outside of the bend, and is therefore disallowed. However, bending normal to the rolling can significantly effect the economy of long bent plate members. For example, a 10 foot long bent plate bracing member would need to be cut from a 10 foot wide plate, or cut from smaller width plates and spliced to obtain the necessary length. Also, this normal bending can result, depending on the member orientation, in the member's primary working stresses acting perpendicular to the rolling.

C4: In most cases ASTM A36 is less expensive than ASTM A572 Grade 50, and ASTM A588 is more expensive than A572. However, the toughness characteristics of A572 steel plates thicker than 2" can be unreliable. Consequently, in order to meet AASHTO welding and toughness requirements, A572 can be more expensive than A588 for these plates. This is especially true of fracture critical members where A572 plates over 1" or 1.5" may be more expensive than A588. The 3" requirement here, a thickness where the distinction between costs is more clear, is from the Staff Bridge Engineer's 1/24/91 Technical Memorandum #2. Permitting A588 to be substituted for A572 in the plans allows the fabricator to select the least expensive and most convenient material.

Bracing, stiffeners, and secondary members are examples of where yield strength oftentimes has a

November 5, 1991	Subsection No. 10.1	Page 3 of 12
POLICY		COMMENTARY

Weathering steel may not be used unless approved by the CDOT Staff Bridge Engineer. Requests to use weathering steel need to be made early in the project. (C5)

Material in tension in primary members (referred to as "main members" by CDOT Standard Specifications) shall meet the longitudinal Charpy V-notch impact test requirements. Either the plans, Project Special Provisions, or Standard Specifications shall designate the structural steel "main members" and the tensile portions of these members. Fracture Critical Members shall be clearly identified on the plans. The plans shall also show the limits of tension flanges.

**10.1.3 COVER PLATES**

Cover plates shall not be used for new construction. Larger rolled beams or welded plate girders shall be used in lieu of cover plates. This is to avoid potential fatigue problems at cover plate termini.

minimal effect on the required sections, because stiffness and stability usually control their design. In which case, A36 should be used. A572 is commonly used for box girder interior pier and abutment diaphragms, and is occasionally needed for bearing stiffeners. Longitudinal flange stiffeners should satisfy allowable bending requirements. Consequently these stiffeners are usually made the same grade of steel as the flange. Although using A36 webs with A572 flanges can provide greater economy on some girders, this Subsection currently disallows hybrid girders. Therefore, A572 webs, matching the flanges, are used.

Note, Grand Junction Steel has found using "bars" (see AISC Manual of Steel Construction for definitions of "bar" and "plate") for stiffeners is usually less expensive than cutting them from plates. Therefore, calling for A572 stiffeners because they use the same size plate as the girder web or flanges will probably increase, instead of decrease, cost and inconvenience. This is probably true of other plate members or components where "bar" could be used.

Designers should keep in mind that small quantities of a given A572 and A588 rolled shape can be very expensive. For example, on a weathering steel bridge, reducing quantities by using several different sizes of A588 bracing members may actually increase costs. Although minimizing the number of different parts is an important rule for structural design in general, it deserves additional attention here.

November 5, 1991	Subsection No. 10.1	Page 4 of 12
POLICY		COMMENTARY

**10.1.4 WELDED GIRDERS**

When designing structural steel elements, conservation of material shall not receive unwarranted emphasis. Simplification of details, reduction of fabricating operations, and ease of erection are often the best means for achieving minimum cost and maximum quality. Changes in plate sizes and the use of stiffeners should be avoided unless the savings in material is significant enough to offset the increased fabrication costs. (C6)

The minimum web plate thickness shall be 3/8 inch. The minimum flange thickness shall be 5/8 inch. The minimum flange width, except box girder bottom flanges, shall be 12 inches. For handling efficiency, the b/t ratio for tension flanges, except box girder bottom flanges, should not exceed 24. For steel box girders, the b/t ratio for the bottom flange in tension shall not exceed 120. Before using plates greater than 8 feet wide, the designer shall check their availability and the costs associated with their use. (C7)

C5: Weathering steel is not typically used in Colorado. Experiences with areas of adjacent concrete becoming stained and with uneven rusting giving non-uniform coloration and texture, as well as concerns about the potential for progressive deterioration in areas of continual moisture and/or high salt exposure, have led to its use being discouraged in the past.

C6: Less material represents economy. But, minimizing the number of stiffeners, different rolled members, and different plate thicknesses does too. Overall savings is achieved with a balance between the two, keeping in mind that as a percentage of total costs, labor costs can readily exceed material costs.

A change in flange plate size that introduces a welded splice should save 700 pounds, or  $[300+25(\text{flange area})]$  pounds to be cost effective (per a Bethlehem and USS publication, respectively). These are older guidelines. Higher values may now be appropriate.

For bridges with typical girder lines, the cost of welded flange plate splices can be reduced when the two flanges at the splice are the same width. This allows the weld to be completed before the flange plates are cut. However, this can work contrary to minimizing the number of different plate thicknesses. Again, a balance must be found.

C7: Staff Bridge has historically established minimum plate sizes to help insure efficient handling, and to provide the boundary below which rolled shapes should be used to obtain an assumed highest quality for the least cost. However, given the subsequent prohibition of cover plates, and

November 5, 1991	Subsection No. 10.1	Page 5 of 12
POLICY		COMMENTARY

On box girders, the preferred distance from exterior face of web to edge of bottom flange is 1.25". (C8)

The web and flanges of a welded girder shall be of the same grade of steel; i.e., hybrid girders may not be used.

**10.1.5 FATIGUE**

Except for bridges on interstate and primary highways, fatigue design shall be based on the 20 year projected ADTT as derived from the final Form 463 or as reported by Staff Traffic. (C9)

the difficulty in splicing rolled shapes of different sizes, these restrictions now make efficient utilization of material more difficult for continuous steel girder bridges in the smaller span lengths. If these restrictions excessively affect the cost of a project, alternative solutions may be submitted to the Staff Bridge Engineer for approval.

The b/t limit of 120 was taken from the FHWA Report Number FHWA-TS-80-205, Proposed Design Specifications for Steel Box Girder Bridges, January 1980, by Wolchek and Mayrbaurl Consulting Engineers.

Previously, plate widths exceeding 8' were prohibited by this Subsection. This was changed because wider plates are available from some steel mills. However, their availability in the length and thickness desired, the plate cost, and shipping costs, need to be determined and considered by the designer. By using longitudinal welded splices, girder webs deeper than 8' have been used. However, the cost of making this splice, and the costs associated with using a girder over 8'deep, need to be considered.

C8: This distance has been requested (and verified on 10/91) by Grand Junction Steel to provide the necessary riding surface for their welding machine.

C9: This paragraph assumes use of the AASHTO Standard Specifications for fatigue design. The AASHTO Guide Specifications for Fatigue Design of Steel Bridges offers several alternative for determining design truck volumes, but these alternatives are for when the guide specification is used.



November 5, 1991	Subsection No. 10.1	Page 6 of 12
POLICY		COMMENTARY

Fatigue design for all bridges on interstate and primary highways shall be based on the Case I stress cycles in the AASHTO Standard Specifications. (C10)

Non-redundant members are defined as members whose failure would be expected to result in collapse of the structure.

**10.1.6 STIFFENERS**

Transverse (vertical) web stiffeners and longitudinal web and flange stiffeners shall be 5/16 inch minimum thickness and shall be welded to the girder with a minimum 1/4 inch continuous fillet weld.

Longitudinal web stiffeners shall not be used, except for girder spans exceeding 165 feet between points of zero dead load moment. (C11)

Transverse stiffeners shall be normal to the top flange and placed on the non-visible side (inside) of exterior girders. The minimum spacing for the first transverse stiffener from the centerline of bearing shall be equal to one-half the depth of the web. The preferred minimum spacing at all other locations is equal to the depth of web. For longitudinally stiffened girders, use the maximum sub-panel depth, instead of the total web depth, in determining these minimum spacings. (C12)

C10: Bridge designers need to be thorough when considering fatigue. Under normal loading conditions, fatigue failure in steel girders is apparently more common than failure due to member load capacity. Unfortunately, the consequences of current fatigue design procedures will not be known for many years, well into the fatigue design life. Taking this into consideration, it was decided to conservatively use Case I fatigue for all interstate and primary highway bridges. In order to monitor the consequences of this requirement, projects where it has a heavy influence on costs should be reported to the Staff Bridge Engineer.

C11: The previous version had a 300 foot span (center to center of bearing) limitation. The current 165 feet between points of zero moment translates to 165 foot simple spans (c/c bearing) and approximately 300 foot interior spans of multi-span continuous girder bridges. It would be preferable to make the stiffeners a function of percent of total material weight saved instead of span length. Or to provide a weighted cost factor for stiffeners. However, until this matter is pursued further, the existing requirement will be used.

C12: These limitations on transverse stiffeners spacings, along with the preceding limitations on longitudinal stiffeners, mandate the use of fewer stiffeners and thicker webs. The intent is to establish a practice of pursuing economy by simplifying and reducing fabrication rather than just reducing the total weight of structural steel used. The quality of fabrication is also positively influenced by increased simplicity.

November 5, 1991	Subsection No. 10.1	Page 7 of 12
POLICY		COMMENTARY

Shop splices of stiffeners, if any, shall be made with full penetration groove welds. These welds shall be completed before the stiffeners are welded to the girder. (C13)

Rectangular sections are preferred over T-sections for bottom flange longitudinal stiffeners. To facilitate welding operations during fabrication the minimum clear distance between the longitudinal stiffener and girder web, or between adjacent longitudinal stiffeners, should preferably be 2'-4". (C14)

To facilitate fabrication, when T-sections are used for bottom flange longitudinal stiffeners, the ratio of the stiffener depth to one-half the stiffener flange width should be greater than or equal to 1.7. (C15)

**10.1.7 BEARING STIFFENERS**

Bearing stiffeners shall be placed with a tight fit against the top flange, or be connected to it by fillet welds. When the top flange is in tension, the tight fit is preferred. When the stiffener is used to connect a diaphragm, the fillet welded, or to flange connection is required.

Where this intent is otherwise satisfied, stiffener spacings less than the depth of web may be used where required for coordination with diaphragm spacing details. This is often needed on heavily curved or skewed I-girder bridges which have tight and inflexible diaphragm spacings.

Spacing stiffeners at one-half the web depth from the centerline of bearings is allowed to give greater flexibility in these high shear areas. This allowance also accommodates the current AASHTO curved girder guide specification requirement for the end of girder stiffener.

C13: CDOT has had problems getting full penetration welds and good workmanship at longitudinal stiffener splices. These welds are often not adequately addressed by the plans or the specifications. The design engineer is to ensure that they are. This applies to longitudinal web and flange stiffeners. It also applies to transverse web stiffeners, although it is unlikely they would require splicing.

C14: Welded and bolted splices are more difficult to make on T-sections than on rectangular sections. The cost of cutting and straightening a W-shape to make a WT-shape can readily exceed the costs of using a rectangular section of "bar" stock or of cut and straightened "plate".

The 2'-4' is based on requests made by Grand Junction Steel.

C15: This ratio ensures good access to the stiffener web and to the stiffener to girder weld.

November 5, 1991	Subsection No. 10.1	Page 8 of 12
POLICY		COMMENTARY

Bearing stiffeners shall be ground to bear against the bottom flange. When used to connect a diaphragm, the stiffener shall be fillet welded to the bottom flange after grinding to bear. Or, in all cases, the stiffener may be attached to the bottom flange with a full penetration groove weld. However, to prevent their potential warping effect on bottom flanges, the full penetration welds are discouraged. (C16)

The angle between bearing stiffeners and the web shall not be less than 60 degrees. Where necessary to connect diaphragms at larger skews, bent plates shall be used. Plates separate from the bearing stiffeners may be used to connect diaphragms, but the 60 degree limitation also applies to these plates. (C17)

When the final grade along centerline of girder is less than 2%, bearing stiffeners may be set perpendicular to the flanges. For 2% grades and larger, bearing stiffeners shall be set plumb. (C18)

**10.1.8 SPLICES**

All splices shall be normal to the top flange and normal to the longitudinal axis of the girder. Field splices shall preferably be located at or near the points of dead load contraflexure.

The preferred maximum length between field splices is 100feet for steel girders. Difficult haul routes and/or limited access to the bridge site may require reducing this length. Piece weights for handling during construction should also be considered when locating splices. (C19)

C16: There have been problems with warping in the bottom flange of box girders. Welds to the bottom flange, especially large welds near the center of a box girder flange, can contribute to, or cause, this warping. Although this experience has been with box girders, placing these large welds across I-girder flanges is similarly discouraged.

C17: For stiffness, bearing stiffeners are most efficient when placed perpendicular to the web. However, when connecting diaphragms, or obtaining the optimum orientation to a bearing device, it may be desirable to skew them. The maximum skew is limited by the AWS requirements for fillet welds. Welds at angles less than 60 degrees (the angle between the web and the stiffener) qualify as partial penetration groove welds and they are not be used where there may be tension perpendicular to the weld length. Note, this applies to all fillet welded t-joints, and not just those at stiffeners.

This limitation also ensures adequate access to the weld. However, the designer should watch for other obstacles to access, for example, adjacent stiffeners or diaphragm connection plates.

When placing stiffeners on skews the designer also needs to remember to calculate the required moment of inertia along the skewed girder's axis, and not an axis perpendicular to the stiffener.

C18: Placing bearing stiffeners normal to flanges can sometimes simplify fabrication. CDOT has used bearing stiffeners up to 2% out of plumb in the past. This practice constitutes the current policy.

November 5, 1991	Subsection No. 10.1	Page 9 of 12
POLICY		COMMENTARY

To facilitate fabrication, where filler plates are used in bolted splices, a note shall be added to the plans permitting the use of oversized holes in the filler plates. The applicable diameter, from AASHTO, shall be given in the note. (C20)

Flange thickness transition ratios shall not exceed 2:1 at welded splices.

The full penetration welds at girder splices shall not be made with backing. The plans shall use the following weld symbol for these connections.

### Missing figure

The designer shall review the shop drawings to ensure that full and complete weld details are shown, and that the welds selected by the fabricator are acceptable. (C21)

#### 10.1.9 CONNECTIONS

Generally, all shop connections shall be welded and all field connections shall be made with high strength bolts. Shop bolted connections should be used when welding would cause difficulty with fabrication or fatigue.

All full penetration welds shall be ground flush for testing. Ultrasonic testing shall be performed on full penetration welds in accordance with the frequency established in the Construction Standard Specifications.

C19: Previously, 100 feet was the maximum length allowed by this Subsection. Since then several steel girder bridges have had shipping lengths between 100 and 122 feet. But these lengths represent maximums which may not be practical or economical on other projects. Note, precast concrete girders up to 150 feet long have been used in the state. But again, as maximums, these lengths are not possible on all shipping routes.

Grand Junction Steel has indicated that both railroad and highway shipping costs can jump higher at lengths greater than about 85'. For instance, they found that in some cases it cost them less to make welded splices than to order plates greater than 85' long.

C20: The procedure used to drill a stack of splice plates by several fabricators requires the splice filler plates to be drilled separately from the splice plates. This can lead to fit-up problems if tolerance on the filler plate hole is not provided. This policy is taken from a 5/16/91 memorandum from the Staff Bridge Engineer.

C21: Full penetration welds made with backing have a relatively high repair rate. The repairs are necessary to eliminate cracks which result from a fusion type of defect between the backing and the base metal. The crack continues to propagate as subsequent weld passes are made. Using the weld symbol shown allows the fabricator to select the full penetration weld details which best suit the associated plate sizes and his means and methods of fabrication. This policy is from the Staff Bridge Engineer's 8/7/91 Technical Memorandum #9.

November 5, 1991	Subsection No. 10.1	Page 10 of 12
POLICY		COMMENTARY

Slip-critical connections shall be made with 3/4" or 7/8" diameter ASTM A325 bolts using Class A friction surfaces. Where special consideration is necessary, requests to use 1" diameter bolts or Class B friction surfaces may be submitted to the Staff Bridge Engineer for approval. (C22)

When Class B friction surfaces are used, the plans shall specify the connection surface conditions that must be present at the time of bolting.

Fastener spacing and edge distances shall satisfy the requirements for bearing capacity, mill and fabrication tolerances, bolt entering and tightening clearances, and AASHTO minimum spacing and edge distance criteria. (C23)

The minimum clearance for entering and tightening high strength bolts shall be determined from the AISC Manual of Steel Construction. Special evaluation will be required for non-orthogonal planes which are not covered by the AISC manual. The overall dimensions of the bolting gun, and the length of tensile control control bolts with their break-off tips attached, need to be considered for non-orthogonal planes and other obstructions.

The designer should assume that tensile control bolts, assembled with a large installation tool, will be used. Where clearances will not allow this, locations where tensile control bolts cannot be used shall be clearly noted in the plans. Tensile control bolts must be used with unpainted A588 steel. (C24)

#### 10.1.10 SHEAR STUDS

The plans shall specify the stud length and diameter used in design. To provide for construction tolerances in the

C22: ASTM A490 bolts are excluded due to potential problems with ductility and obtaining proper tension. These concerns are based on the May 1987 FHWA/R8-87/088 report, High Strength Bolts for Bridges, by the University of Texas at Austin. The construction specifications for structural steel connections submitted by the FHWA, and adopted by CDOT in 1989, similarly exclude A490 bolts.

To facilitate fabrication and construction, CDOT prefers the most commonly used high strength bolt diameters.

The policy on Class A friction surfaces is from the Staff Bridge Engineer's 5/22/90 Policy Letter #4. This letter reported that out of 15 states surveyed, all responded that they did not routinely use Class B slip critical connections.

C23: The minimum spacings and edge distances given by the AASHTO Standard Specifications are currently being interpreted by CDOT as absolute minimums with no tolerance permitted. Rather than calculating the actual total mill and fabrication tolerances needed (which can be found in the CDOT and AASHTO Standard Specifications for Construction, the AISC Manual of Steel Construction, and AWS D1.5), Grand Junction Steel has recommended calling out 3" spacing and 1.75" (2" preferably) edge distance in the plans for 7/8" diameter bolts. To date, this recommendation has been widely accepted and used.

November 5, 1991	Subsection No. 10.1	Page 11 of 12
POLICY		COMMENTARY

haunch depth, the minimum allowable cover from top of stud to top of deck, and from top of stud to bottom of deck, shall also be given. This cover shall not be less than the amount specified by AASHTO, and shall not be less than the specified cover on the deck reinforcing steel.

**10.1.11 CONTROL DIMENSION**

The control dimension "Y" shall be measured from the top of the girder web to the top of the concrete deck (see attached sketch).

To calculate the dimension "Y", add together the following 4 factors:

1. Minimum design deck thickness.
2. Correction for roadway slope = 1/2 maximum flange width times roadway cross slope. This is not required for box girders placed parallel to the cross slope of the deck.
3. Maximum top flange thickness.
4. Excess haunch to allow for fabricating tolerance in girder camber; allow 1 inch for spans 100 feet or less. Allow 1-1/2 inch minimum for spans over 100 feet.

In multiple span structures, dimension "Y" should be constant. Item 4 may be increased as necessary to achieve this. Dimension "Y" should be shown on the Typical Section and designated at the distance from the top of the deck to the top of web at the centerline of the girder and at the centerline of bearing. The concrete portion of the haunch shall not be used to determine section properties for analyzing composite sections except in unusual cases where the haunch, including flange thickness, exceeds 4".

C24: Using high strength tensile control bolts has become standard practice with contractors. Contractors will usually assume they can use tensile control bolts unless directed otherwise. Therefore, designers need to note in the plans bolt locations where, due to clearances, tensile control bolts probably cannot be used.

Uncoated rust resistant load indicating washers are not available, and CDOT has not approved the use of coated washers. The coating can be scraped off during tightening. Therefore, for direct tension indication, only tension control bolts may be used with unpainted A588 steel.

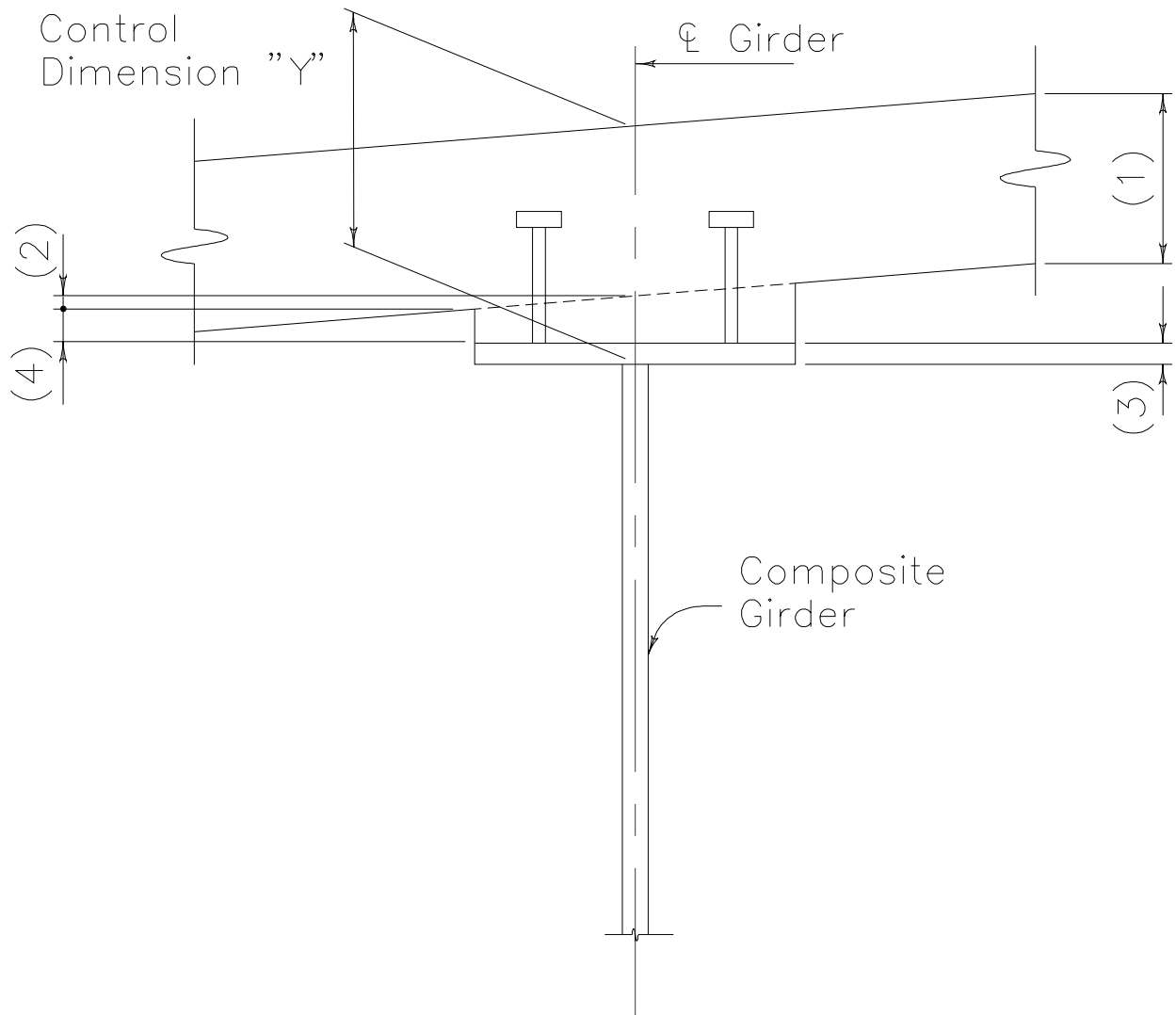

BRACING FOR STEEL GIRDERS

POLICY

COMMENTARY

GENERAL

Cross frames and lateral bracing shall normally be composed of rolled angles, structural tees, or channels and not built up sections or bent plates. The smallest angle used in bracing shall be 3" by 2-1/2" by 5/16". (C1)

There shall not be less than 2 fasteners, or the equivalent weld, at each end connection of the bracing elements. Field connections shall be made by bolting. To facilitate fabrication and erection, oversized holes in gusset plates for diaphragm and lateral bracing connections are preferred. This is a minimum. Skew, curvature, or other considerations may require larger tolerances.

All gussets and connection plates shall be 3/8 inch minimum thickness.

Intermediate diaphragms and lateral bracing shall be ASTM A36 steel except as otherwise approved by the Staff Bridge Preconstruction Engineer.

**DIAPHRAGMS**

Unless noted otherwise, "diaphragms" is used by this Subsection to refer to both beam-type and truss-type transverse bracing for girders. AASHTO refers to these as diaphragms and cross frames, respectively.

Diaphragms for curved I-girders shall be designed as main members when the central angle due to curvature exceeds the limits of Table 1.4A, "Limiting Central Angle for Neglecting Curvature in Determining Moments", of the AASHTO

C1: For internal diaphragms of large box girders, larger minimum angles may be appropriate to improve handling.

4" by 4" by 3/8" minimum angle has been suggested.

C2: The guide specification states that diaphragms are to be "designed as main structural elements to distribute torsional forces to the longitudinal girders." To make the diaphragm design criteria consistent with the criteria for girders, table 1.4A is used to determine when these distributed torsional forces are negligible.



November 5, 1991	Subsection No. 10.2	Page 2 of 4
POLICY		COMMENTARY

Guide Specification for Horizontally Curved Highway Bridges. All other intermediate diaphragms usually need to be designed for kL/r requirements only. (C2)

It is preferable to place intermediate diaphragms perpendicular to the girders (radially to curved girders). (C3)

It shall be noted in the plans when the intermediate diaphragms between two adjacent girders need to be different lengths for proper fit-up. Preferably, the distances between workpoints for each diaphragm should be given. (C4)

The diaphragms at the ends of girders should preferably be placed near and parallel to the centerline of bearing, and set parallel to and 1'-0" below the top of deck. The slab shall be haunched down and supported by the diaphragm, and connected to it with shear connectors. In lieu of these requirements, when girder ends are cast in concrete, provide minimal bracing to restrict girder movement during concrete placement, and to accommodate other loads that may be encountered during construction.

When girder to substructure skews are greater than 20 degrees, gusset plates for intermediate diaphragms (except those inside boxes) shall, as a minimum, have short slotted holes to allow for differential deflection. The following note shall be added to the plans:

Holes in gusset plates to be slotted vertically 1-1/8" x 15/16" for 7/8" diameter H.S. Bolts.

Use 1" x 13/16" for 3/4" diameter high strength bolts in the above note. This is a minimum requirement.

C3: Previously, skewed intermediate diaphragms were prohibited by this Subsection. The current writing allows skewed diaphragms in deference to the AASHTO allowance for intermediate diaphragms skewed up to 20 degrees.

It appears that the primary reason for prohibiting skewed diaphragms in the past was to alleviate fabrication difficulties. Namely, having to skew diaphragm connection plates to the web, and having to fabricate diaphragms of different lengths when the bridge is on a vertical curve. The latter concern is now addressed separately in this Subsection.

Skewed diaphragms provide some degree of restraint to girder rotation about the girder's primary bending axis. This restraint should be kept in mind by designers, especially when skewed diaphragms are used with torsionally rigid girders.

C4: In many instances changes in superelevation, or not having girders parallel to the horizontal control line, can cause the length of intermediate diaphragms to vary. Changes in grade (e.g. when bridge is on a vertical curve) can have the same effect on skewed intermediate diaphragms. In areas of superelevation transition, steel box girders should be made non-parallel to the horizontal control line, as necessary, to obtain typical diaphragm dimensions. CDOT's Bridge Geometry program can compute this varying offset due to superelevation transition.

C5: Previously this Subsection disallowed using transverse stiffeners, that were otherwise required for girder shear, and bearing stiffeners to connect diaphragms. In most applications of full depth diaphragms, the

November 5, 1991	Subsection No. 10.2	Page 3 of 4
POLICY		COMMENTARY

For all bridges, especially when there is skew or horizontal curvature, actual differential deflection should be investigated, and the corresponding requirements for diaphragm fit-up satisfied. Vertical connection plates for connecting intermediate diaphragms to webs shall be rigidly connected to the top and bottom flanges. This may be done by shop welding, or where economical due to fatigue considerations, by bolting. (C5)

ADDITIONAL REQUIREMENTS FOR BOX GIRDERS

In order to avoid problems during construction and erection, and to maintain geometric integrity, lateral bracing and cross frames shall be provided within steel box girders.

Single laced lateral bracing is preferred. Lateral bracing shall be located at, or as near as practical to, the top flange. The connection of lateral bracing to the girder web, or flange, shall be made by bolting. (C6)

The lateral bracing equations for equivalent plate thickness and required stiffness from the AASHTO Guide Specifications for Horizontally Curved Highway Bridges shall not be used. The Kollbrunner Basler equations shall be used for determining equivalent plate thickness. The required area and radius of gyration for bracing members shall be computed using standard analytical methods. (C7)

Temporary external diaphragms between boxes will be required at every other internal intermediate cross frame. When the radius of curvature,  $R$ , is less than 1000 feet, temporary external diaphragms shall be provided at every internal cross frame. (C8)

stiffeners should adequately handle the dual functions of transmitting diaphragm loads to the girder, and stiffening the web. However, the effect of this dual usage should be considered when designing the stiffeners, especially when partial depth diaphragms are used. When desired, separate connection plates for the diaphragms may be used.

C6: The closer lateral bracing is to the top flange, the more efficient it is. However, the clearance needed for forming the deck must be provided. If lateral bracing is connected to the top flange, precast panel deck forms or steel stay-in-place deck forms may be required. If they are, it shall be noted, and adequate haunch depth provided, in the plans.

C7: The lateral bracing equations for equivalent thickness and required stiffness in the current version of the AASHTO curved girder guide specification appear to be in error and therefore may not be used. The Kollbrunner and Basler equations can be found in the 1976 FHWA Curved Girder Workshop manual, and in the 1979 textbook, "Design of Modern Steel Highway Bridges" by Heins and Firmage. The FHWA workshop manual provides an example of computing the required lateral bracing section properties.

C8: These temporary frames serve to unify the overall action of the steel box girders during deck pouring while also providing additional restraint for temperature effects.

The 1000 foot radius requirement was added in the January 1988 edition of this Subsection.

This value was taken from the AASHTO Guide Specifications for

November 5, 1991	Subsection No. 10.2	Page 4 of 4
POLICY		COMMENTARY

Box girders 5 feet and greater in depth shall be made fully accessible for interior inspection. Refer to CDOT Bridge Design Manual Subsection 2.7, Access for Inspection, for additional requirements.

Horizontally Curved Highway Bridges. The specification's impact requirements were only applicable when the radius was less than 1000 feet. Until a resource more directly applicable to diaphragm loads is found, the existing value should be used as a minimum requirement.

STRUCTURAL STEEL FRACTURE CRITICAL MEMBERS

POLICY	COMMENTARY
<p>Fracture critical members or member components (FCMs) are tension members or tension components of members whose failure would be expected to result in collapse of the bridge. (C1)</p>	<p>C1: These paragraphs are taken from Articles 2 and 3 of the AASHTO Guide Specifications for Fracture Critical Non-Redundant Steel Bridge Members. This is not a design specification, but a construction specification for the fabrication of steel FCMs. To make our design policy consistent with this construction specification, the applicable portions have been used for this Subsection. The term "Engineer" in the guide specification has been revised here to refer specifically to the bridge designer.</p>
<p>The responsibility for determining which, if any, bridge member or member component is in the FCM category shall rest with the bridge design engineer. (C1)</p>	<p>C2: This paragraph is taken from the Staff Bridge Engineer's 4/6/89 Technical Memorandum #2.</p>
<p>The bridge design engineer shall evaluate each bridge design to determine the location of any FCMs that may exist. The location of all FCMs shall be clearly delineated on the contract plans. The bridge design engineer shall review the shop drawings to assure that they show the location and extent of FCMs. (C1)</p>	<p>C3: It is anticipated that ANSI/AASHTO/AWS D1.5 will eventually contain a Fracture Control Plan. When it does, CDOT will probably refer to D1.5 for its Fracture Control Plan.</p>
<p>The bridge design notes shall contain the supporting calculations and evaluations as to which members are designated FCMs and why they are so designated. (C2)</p>	
<p>On all projects with FCMs, the contract documents shall contain a Fracture Control Plan (FCP). This plan may be provided directly by the 1991 CDOT Standard Specifications, or by reference to the AASHTO specifications (AASHTO Guide Specifications for Fracture Critical Non-Redundant Steel Bridge Members) in a project special provision. The CDOT Staff Materials Branch shall be consulted as to which method to use. The final specifications and special provisions selected shall be discussed with Staff Materials. (C3)</p>	

November 5, 1991	Subsection No. 10.3	Page 2 of 3
POLICY		COMMENTARY

The Staff Bridge BRIAR unit shall be notified of any new bridge containing FCMs. The bridge designer will provide half-size copies of the bridge plan sheets showing the FCMs and their details. These members and their details shall be highlighted. In addition, the form shown below shall be filled out. This form with the highlighted plans are to be submitted to BRIAR with the Rating Package for the bridge. (C4)

By definition, fracture critical members are non-redundant. The fatigue requirements for non-redundant members given by the AASHTO Standard Specifications shall be closely followed.

C4: This requirement, and the attached form, originated from a 2/21/90 memorandum from the Staff Bridge Construction Engineer. The attached form is presented to illustrate the requested format. This format is to be expanded where necessary to include additional elements, or to give more room for descriptions and sketches. The sketches are to show the fracture critical details that should be looked at. The highlighted plans are to identify the FCMs and the locations of the fracture critical details.

FRACTURE CRITICAL INSPECTIONS

STRUCTURE TYPE: _____	STRUCTURE NO: _____
NO OF SPANS: _____	HIGHWAY NO: _____
NO OF GIRDERS PER SPAN: _____	DATE: _____
YEAR BUILT: _____	

DETAILS THAT ARE FRACTURE CRITICAL:

DETAIL 1 \_\_\_\_\_  
 \_\_\_\_\_

area to inspect: \_\_\_\_\_  
 \_\_\_\_\_

DETAIL 2 \_\_\_\_\_  
 \_\_\_\_\_

area to inspect: \_\_\_\_\_  
 \_\_\_\_\_

DETAIL 3 \_\_\_\_\_  
 \_\_\_\_\_

area to inspect: \_\_\_\_\_  
 \_\_\_\_\_

SKETCH OF DETAIL:

DETAIL 1

DETAIL 2

DETAIL 3

Inspection Date: \_\_\_\_\_  
 \_\_\_\_\_  
 \_\_\_\_\_  
 \_\_\_\_\_

Inspectors Initials: \_\_\_\_\_  
 \_\_\_\_\_  
 \_\_\_\_\_  
 \_\_\_\_\_

COLORADO DEPARTMENT OF TRANSPORTATION  
STAFF BRIDGE BRANCH  
BRIDGE DESIGN MANUAL

Subsection: 10.4  
Effective: August 18, 1989  
Supersedes: New

AASHTO AND ASTM STRUCTURAL STEEL DESIGNATIONS

POLICY

COMMENTARY

Staff Bridge and bridge design consultants shall disregard the new ASTM and AASHTO materials designations in Table 10.2A of the 14th Edition of the AASHTO bridge specifications.

ASTM & AASHTO materials specifications A36, A572, A588 still exist as does AASHTO M183, M223 & M222 in the 1989 edition of the respective materials manuals.

ASTM & AASHTO elected to group all bridge steels together under A709 and M270 respectively. Colorado however, does not use the Quenched and Tempered steels. To eliminate the possibilities of substitutions and the perceived confusion that comes with change and to conform with the new "Bridge Welding Code" ANSI/AASHTO/AWS D1.5-88 which does not address the new M270 structural steel, we will stay with the old designations as long as they are available to us.

---

BRIDGE BEARING FORCES

---

The purpose of a bridge bearing is to support the superstructure at a constant elevation, to carry all forces from the superstructure into the substructure and to allow necessary superstructure motions to take place.

Forces to be applied to bridge bearings can come from any of the loads associated with the bridges. These forces can be combined into the basic loading vectors described below.

*DOWNWARD FORCE*

This force can be considered to act directly through the center of the bearing. It is normally made up of dead load and live load.

*TRANSVERSE FORCE*

This force acts normal to the centerline of the bridge in a horizontal direction at the top of the bearing. It is made up of wind, earthquake and/or other horizontal forces, and must be resisted by keys, anchor bolts, pintles, or other suitable means. The transverse force will develop a moment within the bearing itself, which is equal to the product of the force times the height of the bearing. This moment may be significant for tall bearings and should be included in the analysis.

*LONGITUDINAL FORCE*

This is any horizontal force acting parallel to the centerline of the bridge, including thermal motion forces and forces due to concrete shrinkage. Longitudinal forces generally will not be developed in an expansion bearing. Expansion bearings may, however, develop significant longitudinal forces due to sliding or rolling friction and shear deformation forces in neoprene bearings. Where these forces may exist, they must be accounted for in the design. Curved bridges require special consideration.

*UPLIFT FORCES*

With the exception of elastomeric pads, bearings shall be designed for uplift forces due to earthquake in an amount equal to ten percent of the vertical dead load reaction of the superstructure.

*OTHER FORCES*

Rotational bearing forces in each of the three planes may be developed by a particular structure. These forces should be considered and accounted for in the design when they are significant.



---

BRIDGE BEARING FORCES

---

The purpose of a bridge bearing is to support the superstructure at a constant elevation, to carry all forces from the superstructure into the substructure and to allow necessary superstructure motions to take place.

Forces to be applied to bridge bearings can come from any of the loads associated with the bridges. These forces can be combined into the basic loading vectors described below.

*DOWNWARD FORCE*

This force can be considered to act directly through the center of the bearing. It is normally made up of dead load and live load.

*TRANSVERSE FORCE*

This force acts normal to the centerline of the bridge in a horizontal direction at the top of the bearing. It is made up of wind, earthquake and/or other horizontal forces, and must be resisted by keys, anchor bolts, pintles, or other suitable means. The transverse force will develop a moment within the bearing itself, which is equal to the product of the force times the height of the bearing. This moment may be significant for tall bearings and should be included in the analysis.

*LONGITUDINAL FORCE*

This is any horizontal force acting parallel to the centerline of the bridge, including thermal motion forces and forces due to concrete shrinkage. Longitudinal forces generally will not be developed in an expansion bearing. Expansion bearings may, however, develop significant longitudinal forces due to sliding or rolling friction and shear deformation forces in neoprene bearings. Where these forces may exist, they must be accounted for in the design. Curved bridges require special consideration.

*UPLIFT FORCES*

With the exception of elastomeric pads, bearings shall be designed for uplift forces due to earthquake in an amount equal to ten percent of the vertical dead load reaction of the superstructure.

*OTHER FORCES*

Rotational bearing forces in each of the three planes may be developed by a particular structure. These forces should be considered and accounted for in the design when they are significant.

COLORADO DEPARTMENT OF TRANSPORTATION STAFF BRIDGE BRANCH BRIDGE DESIGN MANUAL	Subsection: 14.2 Effective: August 1, 2002 Supersedes: May 1, 1992
BEARING DEVICE TYPE I AND TYPE IV	
Policy	Commentary

Type I and Type IV bearings can be fixed or expansion-type. Refer to Staff Bridge Worksheets B-512-1 and B-512-4 for details and to the CDOT Standard Specifications, Section 512, for fabrication requirements.

The design shall be in accordance with Chapters 10 and 14 of AASHTO and the AASHTO Specifications for Seismic Design. Unless approved by the Bridge Engineer, steel reinforced elastomeric bearings shall be designed in accordance with AASHTO Chapter 14, Method 'B'. (C1)

The shear strain shall not exceed 50%.

Total movement shall be determined by using the methodology provided in Section 15 for expansion joints, without a temperature safety factor, except that the skew factor will not be used to reduce the magnitude of movement.

Elastomer hardness greater than 60 Durometer shall not be used in reinforced bearings.

Leveling pads used for locked-in girders shall be included in the cost of the work and shall be designed in accordance with AASHTO Chapter 14 for dead load only without considering longitudinal, transverse and rotational movements. Leveling pads shall be thick enough to prevent girder-to-support contact due to anticipated girder rotations up through and including the deck pour.

*C1:* AASHTO Method 'B' allows higher compressive stresses and more slender bearings, which can lead to reduced horizontal forces on the substructure. However, these bearings need to be tested due to the relaxed procedures of design. It is especially important to check concrete bearing stresses when using AASHTO Method 'B'.

The plates embedded in precast girders are included in Item 618.

Type IV bearings are primarily used as a competitive alternate to Type III Bearings. Only one bearing type shall be used across the width of the bridge at any given substructure location.

Sole plates shall be a minimum 3/4" thickness.

BEARING DEVICE TYPE II AND TYPE V

---

Type II and Type V Bearings shall be used as expansion bearings. Refer to Staff Bridge Worksheets B-512-2 and B-512-5 for details and to the CDOT Standard Specifications Section 512 for fabrication requirements.

Refer to Section 10, 14, and 15 of AASHTO for compressive stress, strain, and rotation criteria and the AASHTO Specifications for Seismic Design.

The design coefficient of friction between the PTFE and stainless steel shall be 8%.

Refer to *Subsection 14.2* for additional design requirements.

Type V Bearings are primarily used as a competitive alternate to Type III bearings. Only one bearing type shall be used across the width of the bridge at any given substructure location.

BEARING DEVICE TYPE III

1. Refer to CDOT Staff Bridge Worksheet B-512-3 for details.
2. Refer to Predated Special Provision 512 for fabrication and construction requirements.
3. Refer to Section 15 of AASHTO for PTFE requirements.
4. When the loading and rotational requirements are impractical for a Type II Bearing, a Type III Bearing shall be used.
5. The coefficient of friction for the interface of PTFE and stainless steel shall be 5%.
6. The plans shall include a plan view showing the orientation of the bearings along the bent line. One line of guided bearings is desirable near the centerline of the structure.
7. Designate the bearings as follows:
  - a. Multidirectional movement EXP
  - b. Guided GD
  - c. Fixed FX
8. The lateral loading of a bearing shall not exceed 1/6 of the vertical loading. If the total lateral capacities of the FX and GD Bearings are less than the total calculated horizontal load to the bridge unit, additional lateral restraint must be provided ( i.e. pintles).
9. The allowable loading on any PTFE surface shall be 3500 psi.
10. Type I and Type II Bearing Devices shall not be mixed with Type III Bearing Devices.
11. These bearings shall be paid for as "each" under Item 512 and shall include anchor bolts, sole plates, masonry plates, and the internal manufactured components.
12. The temperature (Fahrenheit) ranges for determining movements are:
  - a. Steel girders - 140 degrees.
  - b. Concrete girders - 180 degrees (Includes a factor of 2 to account for creep and shrinkage).
  - c. The sole plates and top plates shall be oversized an additional 4 inches, longitudinally.
13. Bearings shall be removable. (This is to be accomplished by raising the structure 1/4 inch.)
14. Substructure drawings shall show locations for lifting the superstructure when removing bearing.
15. The minimum bearing height shall be 7 inches.

BRIDGE DECK EXPANSION JOINTS

---

Over the years, many different expansion device systems have been used on our bridges. Most have developed problems that have resulted in the need for replacement. Additionally; significant damage to substructures, bearings and girder ends has resulted from leaking expansion joints. However, no expansion joint system has been found that is entirely problem free.

The primary objective of expansion devices is to allow for expansion and contraction of a bridge structure yet seal the deck and provide protection for bridge girders, bearings and substructure elements from leaking water. An additional objective is to provide a smooth, quiet roadway riding surface.

The armored elastomeric strip seal joints have had the best long term performance and are the recommended joint for use on all new construction, at the ends of approach slabs, and at any joint with anticipated movement of 100 mm (4") or less. For details of these expansion devices, refer to CDOT Staff Bridge WorkSheets series B-518 and B-601-1.

For movements greater than 100 mm (4"), modular joints consisting of multiple elastomeric strip seals are recommended. For typical details of modular expansion devices refer to CDOT Staff Bridge Worksheets Series B-518.

Proper design and application of expansion joints are essential. Skews, horizontal and vertical alignment, grade and cross slopes should all be considered when selecting and designing a joint system. For projects that will have concrete pavement and unprotected concrete decks, it is recommended that the expansion joints be installed in prepared blockouts after the final pavement is in place and all irregularities have been corrected. This will allow adjusting the final profile of the joint to match the adjacent pavement. Refer to CDOT Staff Bridge Design Manual Subsection 7.2 for criteria regarding the structure length requiring bridge expansion devices.

Proper installation is the key to the adequate performance of a well designed joint. To facilitate proper alignment of joints, the bridge geometry should include a bent line with finished grade elevations at the center line of the expansion joint. Elevations are required at all curb faces, grade breaks, and at intervals sufficient to define the profile along the joint on any curve and skew. Joints should be installed in one continuous unit if at all possible.

The asphaltic plug joint system that gained recent popularity due to its ease of construction has not preformed as well as the elastomeric strip seal joints. Because of its limited movement capabilities and relatively high costs, it shall not be considered for new construction. This type of joint has only limited application for emergency repairs and temporary installation.

Use of elastomeric concrete headers is not encouraged. Removal and reconstruction of the joint anchorage portion of bridge decks is the recommended repair procedure for joints and the installation of 0-100 mm (0-4 inch) or modular expansion devices.

DESIGN PROCEDURE FOR 0" TO 4" EXPANSION DEVICE

1. Determine the portion of total length of structure that will contribute to movement at the joint under consideration.
2. For STEEL superstructures, the temperature range shall be 150° (F) and the coefficient for thermal expansion shall be 0.0000065/(degrees(F)).

For CONCRETE superstructures, the temperature range shall be 90° (F) and the coefficient for thermal expansion shall be 0.000006/(degrees (F)).

3. The sine of the skew angle between the center line roadway and the joint shall be used to determine the horizontal component of movement normal to the expansion device.
4. For STEEL girder bridges, the horizontal component due to thermal movement shall be multiplied by 1.30. This is an empirical factor which accounts for a factor of safety, movement not normal to joint, and live load rotations.

For CONCRETE girder bridges, the horizontal component due to thermal movement shall be multiplied by an empirical factor of 2.00. This accounts for a factor of safety, movement not normal to joint, live load rotations, differential shrinkage, creep, moisture content, and elastic shortening.

5. In the formula below, total horizontal movement normal to expansion device shall = HM.

HM = L(TR) (ct) (sine skew) (tn)  
l = maximum contributory length in inches  
tr = temperature range of steel or concrete from step 2  
ct = coefficient of thermal expansion of steel or concrete from step 2  
skew = skew angle defined in step 3  
tn = empirical factors for steel or concrete from step 4

6. If hm exceeds 4", stop. you cannot use this design aid. you must use the design aid for modular type expansion devices. If hm is less than 4", you are ready to determine the "a" dimension in the chart on page 2 of this Subsection.

STRUCTURE TEMPERATURE (T) °F	"A" INCHES
30	
40	
50	
60	
70	
80	
90	
100	

For steel girders, use the following formula:

$$A = HM/1.30 + (40 - T) (HM/150)$$

$$= HM(2020 - 13T)/1950$$

For concrete girders, use the following formula:

$$A = 0.25 + HM(100 - T)/(2.00) (90)$$

The 0.25" is the minimum opening to be set during placement of the device at 100° (F). In other words, the device may never be completely closed when it is placed. You may, however, use 3/16" as a minimum opening during placement of the device when determining the "A" dimension.

The examples that follow on pages 3 and 4 are to be used as a guide for using the above formulas. These examples may not reflect actual conditions or constraints of your bridge.



## EXAMPLE:

Determine the "A" dimension for 0" to 4" expansion devices at abutments 1 and 6 for a 5 span (100'-0", 100'-0", 130'-0", 100'-0", 100'-0") Welded Plate Girder Continuous Bridge, skewed 53 degrees.

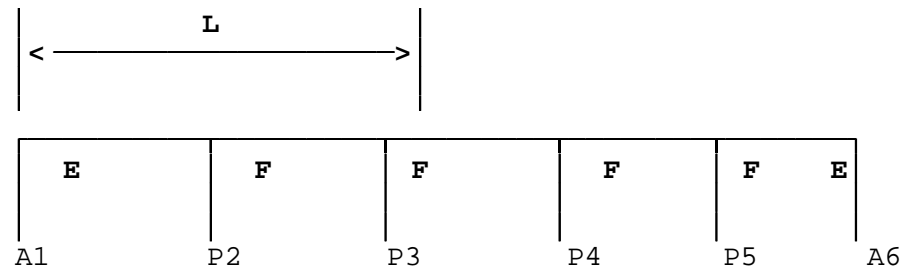

## SOLUTION:

1.  $L = ( 100 + 100 + 130/2 ) (12) = 3180"$
2.  $ct = 0.0000065/(^{\circ}F), \quad TR = 150 (^{\circ}F)$
3. Skew = 53 degrees
4.  $TN = 1.30$
5.  $HM = (3180)(150)(.0000065)(\sin 53)(1.30) = 3.219" < 4" \text{ OK}$
6.  $A = 3.219(2020 - 13(30))/1950 = 2.691" @ 30 \text{ degrees (F)}$   
 $A = 3.219(2020 - 13(40))/1950 = 2.479" @ 40 \text{ degrees (F)}$   
 $A = 3.219(2020 - 13(50))/1950 = 2.262" @ 50 \text{ degrees (F)}$   
 $A = 3.219(2020 - 13(60))/1950 = 2.046" @ 60 \text{ degrees (F)}$   
 $A = 3.219(2020 - 13(70))/1950 = 1.832" @ 70 \text{ degrees (F)}$   
 $A = 3.219(2020 - 13(80))/1950 = 1.618" @ 80 \text{ degrees (F)}$   
 $A = 3.219(2020 - 13(90))/1950 = 1.403" @ 90 \text{ degrees (F)}$   
 $A = 3.219(2020 - 13(100))/1950 = 1.189" @ 100 \text{ degrees (F)}$

Rounding to the nearest 1/16", complete chart.

STRUCTURE TEMPERATURE °F	"A" INCHES
30	2 11/16
40	2 1/2
50	2 1/4
60	2 1/16
70	1 13/16
80	1 5/8
90	1 3/8
100	1 3/16

EXAMPLE:

Determine the "A" dimension for 0" to 4" expansion devices at abutments 1 and 7 for a 6 span (85'-0", 85'-0", 140'-0", 140'-0", 85'-0", 85'-0"). Prestressed Concrete Girder Continuous Bridge, skewed 67 degrees.

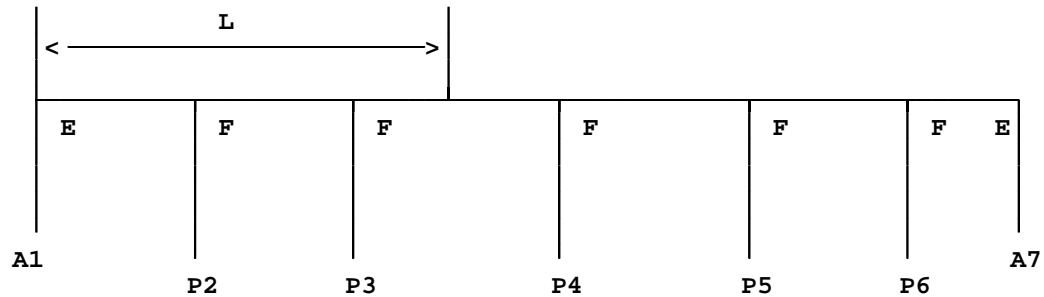

SOLUTION:

1.  $L = (85 + 85 + 140)(12) = 3720"$
2.  $ct = 0.000006/(\text{deg. F}), TR = 90 \text{ Degrees F}$
3. Skew = 67 degrees
4.  $TN = 2.00$

5.  $HM = (3720)(90)(.000006)(\sin 67)(2.00) = 3.698" < 4" \text{ OK}$
6.  $A = 0.25 + 3.698(100 - 30)/180.0 = 1.688" @ 30 \text{ degrees F}$   
 $A = 0.25 + 3.698(100 - 40)/180.0 = 1.483" @ 40 \text{ degrees F}$   
 $A = 0.25 + 3.698(100 - 50)/180.0 = 1.277" @ 50 \text{ degrees F}$   
 $A = 0.25 + 3.698(100 - 60)/180.0 = 1.072" @ 60 \text{ degrees F}$   
 $A = 0.25 + 3.698(100 - 70)/180.0 = 0.866" @ 70 \text{ degrees F}$   
 $A = 0.25 + 3.698(100 - 80)/180.0 = 0.661" @ 80 \text{ degrees F}$   
 $A = 0.25 + 3.698(100 - 90)/180.0 = 0.455" @ 90 \text{ degrees F}$   
 $A = 0.25 + 3.698(100 - 100)/180.0 = 0.250" @ 100 \text{ degrees F}$

Rounding to nearest 1/16", complete chart.

STRUCTURE TEMPERATURE °F	"A" INCHES
30	1 11/16
40	1 1/2
50	1 1/4
60	1 1/16
70	0 7/8
80	0 11/16
90	0 7/16
100	0 1/4

DESIGN PROCEDURE FOR MODULAR EXPANSION DEVICE

1. Determine the portion of total length of structure that will contribute to movement at the joint under consideration.
2. For STEEL superstructures, the temperature range shall be 150° (F) and the coefficient for thermal expansion shall be 0.0000065/f (F).

For CONCRETE superstructures, the temperature range shall be 90° (F) and the coefficient for thermal expansion shall be 0.000006/f (F).

3. The skew angle is defined as the angle between the center-line roadway and the center-line joint. If motion is not parallel to center line roadway (curved bridges, for instance), use the line of motion instead of center-line roadway. For a skew angle greater than or equal to 45f, the sine of the skew angle shall be used to determine the horizontal component of movement normal to the expansion device. For a skew angle less than 45f, racking of the device becomes significant, and therefore, the device must be designed to absorb the total movement in the direction of the center-line roadway (sine skew = 1). In other words, the device will, of course, be built along the skew, but it will be sized and the "A" dimension chart filled out as though the device was normal to the center-line roadway.
4. For STEEL girder bridges, the horizontal component due to thermal movement shall be multiplied by 1.30. This is an empirical factor which accounts for a factor of safety, movement not normal to joint, and Live Load rotations.

For CONCRETE girder bridges, the horizontal component due to thermal movement shall be multiplied by an empirical factor of 2.00. This accounts for a factor of safety, movement not normal to joint, Live Load rotations, differential shrinkage, and creep.

5. In the formula below, HMED = the size of the modular expansion device required. HMED should be rounded up to the nearest 3 inch increment.

$$\text{HMED} = L(\text{TR})(\text{ct})(\text{sine skew})(\text{TN})$$

L = maximum contributory length in inches

TR = temperature range of steel or concrete from step 2

ct = coefficient of thermal expansion of steel or concrete from step 2

Skew = skew angle defined in step 3

TN = empirical factors for steel or concrete from step 4

6. If HMED is less than 4", STOP. You cannot use this design aid. You must use the design aid for 0-4 inch Expansion Devices. If HMED is greater than 4", you are ready to determine the "A" dimension in the chart. A standard modular device cannot handle a HMED dimension greater than 22 inches.

A modular expansion device consists of premolded elastomeric expansion joint seals mechanically held in place by extruded steel separation beams.

Each elastomeric seal can absorb 3" of structure movement. Therefore, the device shown above is a 0-9 inch device. A 0-12 inch device would have one more elastomeric seal and one more separation beam, and so on.

STRUCTURE TEMPERATURE (T) °F	"A" INCHES
30	
40	
50	
60	
70	
80	
90	
100	

For STEEL GIRDERS, the elastomeric seals should be half closed at the median temperature of 40° (F). Therefore,

$$A(40^\circ) = (1-1/2") (\text{No. of elastomeric seals}) + (3") (\text{No. of separation beams})$$

To complete the "A" dimension chart, add or subtract the following unfactored 10° increment to A(40°):

$$\text{Increment} = \frac{\text{HMED}}{(1.30)} \frac{(10)}{(150^\circ)}$$

For CONCRETE GIRDERS, each elastomeric seal should be 1/4" open at 100° (F). Therefore,

$$A(100^\circ) = (1/4") (\text{No. of elastomeric seals}) + (3") (\text{No. of separation beams})$$

This results in a more closed device initially than would be obtained using the steel girder procedure. The purpose of this is to allow for creep (in prestressed girders) and shrinkage which will open the device over time. To complete the "A" dimension chart, add the following unfactored 10° increment to A(100°):

$$\text{Increment} = \frac{\text{HMED}}{(2.00)} \frac{(10^\circ)}{(90^\circ)}$$

The acceptable manufacturer's alternates for modular devices are:

Wabo-Maurer - as furnished by:

Watson-Bowman Acme  
95 Pineview Drive  
Amherst, New York, 14120                      Tel (716) 691-7566

Maurer - as furnished by:

D. S. Brown Company  
P.O. Box 158  
North Baltimore, Ohio 45872                      Tel (419) 257-3561

The example that follows is to be used as a guide for using the above formulas. This example may not reflect actual conditions or constraints of your bridge.

**EXAMPLE:**

Determine the "A" dimension for modular expansion devices at abutments 1 and 6 for a 5 span (200'-0", 200'-0", 230'-0", 200'-0", 200'-0") Welded Plate Girder Continuous Bridge, skewed 53 degrees.

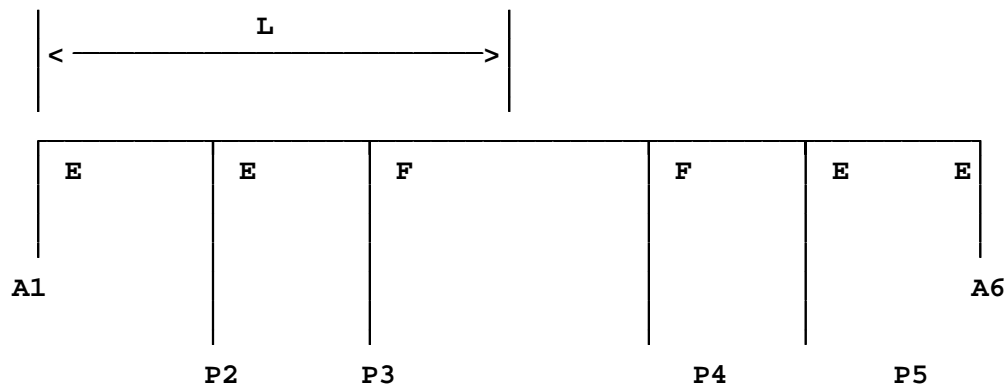

**SOLUTION:**

1.  $L = (200 + 200 + 230/2) (12) = 6180"$
2.  $ct = 0.0000065/(^{\circ}F)$ ,  $TR = 150^{\circ} (F)$
3.  $Skew = 53^{\circ}$
4.  $TN = 1.30$
5.  $HMED = (6180) (150) (0.0000065) (\sin 53) (1.30) = 6.26" > 4" \text{ OK}$
6. Use 0-9 Inch Modular

$$A(40^{\circ}) = (1-1/2)(3) + (3")(2) = 10.5"$$

$$\text{Increment} = \frac{(6.26)(10)}{(1.3)(150)} = 0.32 \text{ use } 5/16"$$

The completed chart is shown:

STRUCTURE TEMPERATURE °F	"A" INCHES
30	10 13/16
40	10 1/2
50	10 3/16
60	9 7/8
70	9 9/16
80	9 1/4
90	8 15/16
100	8 5/8

COLORADO DEPARTMENT OF TRANSPORTATION STAFF BRIDGE BRIDGE DESIGN MANUAL	Subsection: 16.1 Effective: November 1, 1999 Supersedes: January 1, 1990
BRIDGE DRAINAGE	

All bridges shall be investigated for drainage requirements. The FHWA publication, *Design of Bridge Deck Drainage*, Hydraulic Engineering Circular No. 21 (HEC-21) (Publication No. FHWA-SA-92-010, May 1993), shall be used for the design of Bridge Drainage Systems. The hydraulic design frequency shall be 5 years rather than the frequencies specified in HEC-21. The maximum spread width shall not encroach into through driving lanes.

When deck drainage is necessary, designers shall decide how it will be incorporated in a bridge early in the design process, ideally, when the girder spacing is determined. Designers need to be aware that deck drains will have an impact on other structural components that will carry throughout the design of the bridge.

A complete Bridge Drainage System (BDS) consists of a Bridge Deck Drainage System (BDDS) and a Bridge End Drainage System (BEDS). The BDDS includes all drains located on the bridge deck and the means used to convey the water collected by them. The BEDS intercepts drainage immediately upslope and downslope of the bridge and shall daylight between 150 mm and 300 mm (6" and 1') above the toe of the fill or the rip-rap at that location.

Designers shall perform a structural analysis on all bridge components modified to accommodate deck drains. The amount of reinforcing steel may need to be increased or structural components thickened in the vicinity of the deck drains depending on the outcome of the structural analysis. Designers may need to adjust the girder spacing and deck overhang length, notch the girder flange, or adjust drain locations due to the proximity of bridge rail posts to incorporate deck drains in a bridge. Flanges may be notched (with transitions) near abutments where the bending moment is low without adverse impact since the flange beyond the web does not contribute to the shear strength of the girder. Flanges may also be notched near piers on simple span girders made continuous since the negative moment reinforcing steel in the deck is in tension. Precast, prestressed girders can have voids formed in the top flange by the fabricator or if the bridge is retrofitted, a portion of the flange removed (the prestress force should redistribute in the deck).

The station and offset for each deck drain shall be specified on the plans. All deck, curb, and bridge rail reinforcing steel impacted by the presence of deck drains shall be detailed on the plans.

Drainage from structures shall not drip onto bearings, pier caps, abutment caps, nor onto roadways, railroad templates, pedestrian walkways, bicycle paths, slope paving, or unprotected fill slopes. For free fall drains, the horizontal distance necessary to keep wind-driven drainage away from piers or other features is 3 m (10'). Pipes from deck drains shall extend at least 75 mm (3") below the bottom of the adjacent girder.

When a BDS is specified, a reasonable and acceptable hydraulic path for the discharge shall be detailed on the plans, beginning at the outfall. Drainage may be allowed to discharge directly into waterways (depending on the site) provided the ADT does not exceed 30,000 per the CDOT National Pollutant Discharge Elimination System (NPDES) Task Force (August 1992). At present, this is not a regulation. When the ADT exceeds 30,000, drainage should be directed to a storm water quality management facility, including but not



limited to, a grass lined swale, grass buffer strip, or a detention pond. The preferred discharge area is not in the area occupied by the ordinary high water.

Pipes attached to deck drains should be capable of removal in the field by mechanical means. The welding of steel pipe to gray iron castings is strongly discouraged since it cannot be readily disassembled. The weld can be made with a nickel electrode, but the connection is weak. This connection should be considered and used only as a last resort.

Schedule 40 pipe shall be used for the BDDS and may be either galvanized steel or polyvinyl chloride (PVC). The PVC pipe should be painted to match the color of the adjacent bridge component such that the color doesn't contrast (the PVC should be lightly abraded to make the appropriate primer adhere). Pipes which convey drainage shall be a minimum of 203 mm (8") in diameter. Bends in pipe shall not exceed 45 degrees and shall have a 610 mm (2'-0") minimum radius. Clean outs shall be located at all bends.

The discharge end of the BDDS shall be between 150 mm and 300 mm (6" and 1') above the finished grade elevation (final ground line) at piers. Erosion protection is required since the exit velocity of the discharge is high. The erosion protection may include rip-rap with filter cloth beneath, a concrete splash block, or a concrete lined channel. See the Culvert Outlet Paving Detail shown on CDOT Standard Plan M-601-12.

Deck drain grates shall be designed for the highway wheel loading and bicycle safety, when appropriate. Deck drains available from the Neenah Foundry Company are designed for the M 18 (H 20) wheel loading. Designers may specify that deck drains be installed 15 mm (1/2") lower than the surrounding deck to reduce the snag potential of the grate from snow plow blades.

Galvanizing gray iron castings is not desirable or necessary. While the structural steel components of drains must be galvanized, the use of steel for deck drains is discouraged since gray iron offers superior corrosion resistance over galvanized steel. The use of reinforcing steel or weathering structural steel for deck drain components is prohibited.

The use of curb cuts for deck drains is discouraged due to their poor hydraulic performance and maintenance history. HEC-21 discusses a drain such as this in the last paragraph of Section 5.1. That paragraph concludes with the following sentence: "Perhaps the best comment on their usage is that they may be better than nothing." There are design concerns with curb cuts since the curb is an integral part of the bridge rail. AASHTO Article 2.7.1.1.3 states, "Traffic railings should provide a smooth continuous face of rail..." This requirement precludes any break in the curb necessary for a curb cut. If curb cuts are specified, the water captured shall be carried to a point at least 75 mm (3") below the bottom of the exterior girder before being released.

---

DECK DRAINS

---

Structures should be drained as necessary and water shall be kept away from bearing devices. If possible, drains should not be positioned above riprap. When drains must be placed over riprap, special filter fabric shall be placed under the riprap. This filter fabric shall be highly permeable and non-biodegradable.

Curb cuts shall not be used when they would allow water to drain across adjacent walkways.

Drainage from structures shall not drip onto girder flanges, bearings, pier caps, or abutment caps, nor onto roadways, railroad templates, or pedestrian/bikeways.

Pipe drains, scuppers, and grated inlet drains shall extend below bottom of deck to assure that drainage is kept off steel girder flanges.

Curb drains shall be as shown in Figure 9-2 of the CDOT Bridge Detailing Manual and shall provide a continuous curb for wheel impact.

Pipe drains shall have a minimum diameter of 6 inches and a maximum diameter of 8 inches. Pipe drains shall have internal grates 2 inches below the surface or be covered by a grate designed for HS 20 wheel loading. Inlet grates shall be removable for cleaning. Project specific details shall be included.

SCOUR

**GENERAL**

The following is taken directly from the Staff Bridge Engineer's 5/22/90 Policy Letter Number 5.

The Hydraulics unit is now designing all structures for an appropriate design frequency, then checking the channel structure for stability and scour effects for a 500 year event. This information will be plotted on the Hydraulics sheet for all major structures by the Hydraulics unit.

We will show the elevation of the maximum combined scour depth on the General Layout. If individual substructures have significantly different depths, they should all be shown separately.

The structures shall continue to be designed per AASHTO as presently done, but considering potential scour effects on your structure type. When the final scour calculations are received, a stability check of the structure will be performed and, if necessary, a redesign of the substructure units or foundations may be required.

Spread footings should be located such that the top of footings are below the total anticipated scour level and the bottom of the footings at least 6 feet below the streambed.

Each substructure unit shall be treated independently; i.e., the footing depths need not all necessarily be below the thalweg for the 500 year event.

In the event that the 500 year flow would over-top the structure, the designer should determine the appropriate AASHTO loads and groupings to apply during the stability analysis.

**FOOTING SUPPORTED BY PILES OR CAISSONS**

The following is from the Staff Bridge Engineer's 5/22/90 Technical Memorandum Number 6.

There is no benefit to be gained in the reduction of local scour by placing the top of footings supported by piles or caissons at an elevation other than flush with the streambed. This is especially the case in those instances where neither contraction scour nor general degradation are expected to be significant. As a general rule the disturbance of the streambed below this level is discouraged.

In those cases where contraction scour or general degradation is predicted in the hydraulic analysis the designer may consider locating the top of the footing at the elevation of the projected level of scour. Should contraction scour be predicted to exceed about 10% of the design depth of flow, the contracted opening should be re-evaluated. General degradation may be more difficult to control or even be aware of because of the potential lack of historical knowledge to predict at all stream locations.

The preceding two paragraphs should not be interpreted to apply to spread footings, in which case AASHTO minimums and other criteria shall apply except when otherwise controlled by hydraulic scour predictions.

---

TELEPHONE CONDUITS

---

**GENERAL**

Telephone companies may request permission to attach telephone conduits to bridge structures proposed for construction on the Colorado Highway System. All such requests should be coordinated through the District Utility Engineer, who should submit the request, in writing, to Staff Bridge Design. Such requests must state the proposed schedule for installation, the location of the conduits, the type of conduit sleeve required, and the size, spacing, capacity, and number of inserts. For Off-system projects, requests for conduits will be processed as outlined at the predesign meeting. For aesthetic and safety reasons, conduits will not be permitted under deck overhangs or on bridge railing.

The Contractor will install sleeves for conduits through abutments, pier caps, and diaphragms and will install concrete inserts. The sleeves and inserts will be supplied by the telephone company. The cost of installation will be included in the work to avoid the time and costs involved in separate contract negotiations for reimbursement from the telephone company. Installation of hangers, conduit, and expansion devices will be handled by the telephone company.

The plans shall indicate the size, spacing, and capacity of the inserts, the basis of payment for installation, and what materials are to be furnished by the telephone company.

COLORADO DEPARTMENT OF TRANSPORTATION STAFF BRIDGE BRIDGE DESIGN MANUAL	Subsection: 17.2 Effective: April 10, 2000 Supersedes: July 1, 1988
UTILITY BLOCKOUTS	

Blockouts shall be sized to accommodate only those utilities to be installed during bridge construction. When attending the FIR meeting, designers should inquire as to what utilities the bridge will carry to assure that they are accommodated.

Blockouts shall not extend below the bottom of the superstructure. Some utilities may be accommodated by placing them in PVC pipes cast in precast, prestressed concrete box girders.

The effect of the abutment backfill settling on the utility needs to be considered by the designer. The means used to prevent the utility from being pinched where it projects from the abutment shall be detailed on the plans. Collapsible cardboard void material of sufficient height, width, and length, above the utility may be one of the means used to address that problem.

Blockouts that allow for the installation of "future" utilities shall not be provided. In the past, blockouts have been provided in the exterior bays of abutments and piers of some bridges, but they were rarely, if ever, used once the "future" utility was installed. The installation of a utility through a vacant abutment blockout of an in-service bridge would require removal of portions of the approach slab (if existing), temporary excavation shoring, excavation of the abutment backfill, and traffic control, making it unlikely a utility would elect to locate there. Virtually all utilities installed on bridges in service are attached to the soffit of the deck overhang, regardless of the impact to bridge aesthetics.

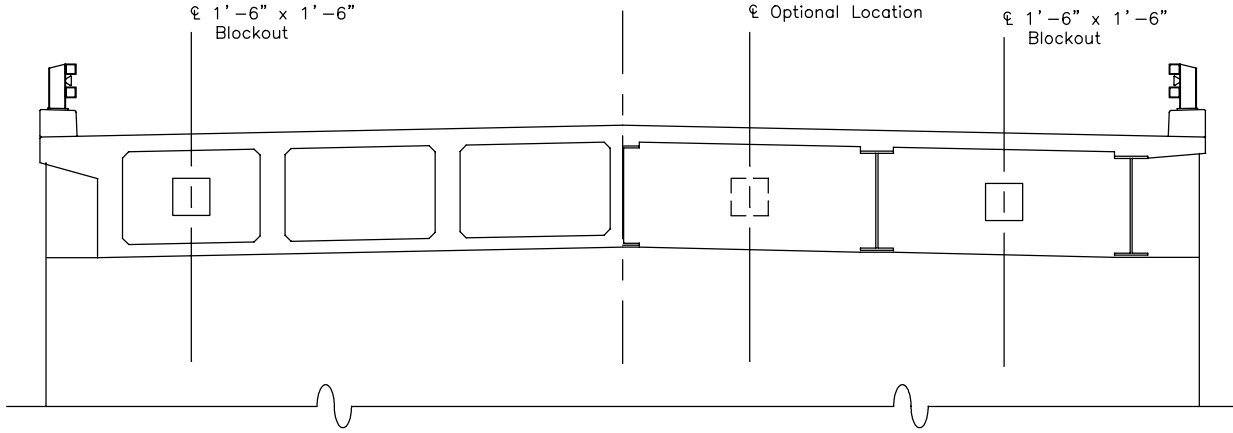

ELEVATION

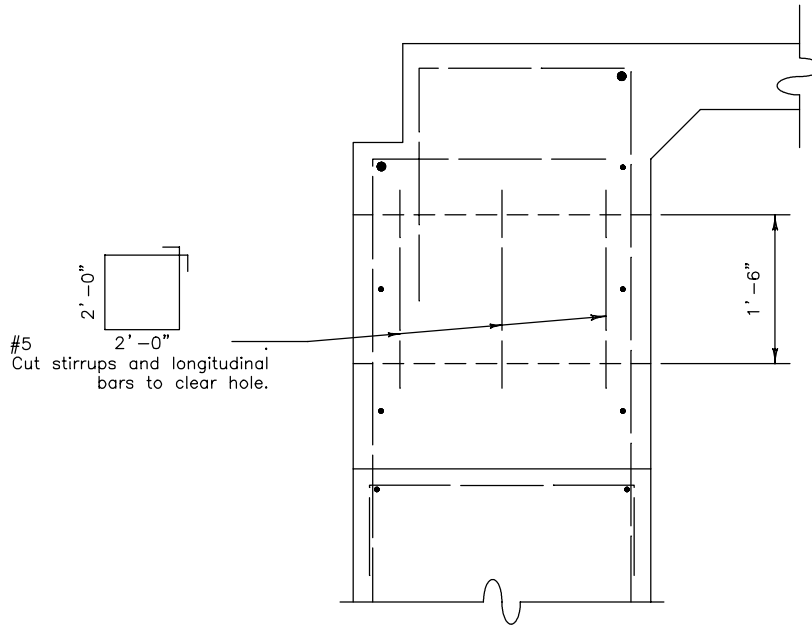

SECTION

TYPICAL ABUTMENT BLOCKOUT DETAIL

The typical abutment blockout detail should be modified as required.

BRIDGE LIGHTING

---

**TOP MOUNTED**

Bridge-mounted highway lighting shall be avoided wherever possible. The designer shall investigate the possibility of mounting the lighting on an extended pier cap. If bridge-mounted lighting cannot be avoided, it shall be located as close to a pier as is practical.

**UNDERNEATH**

Bridges crossing all public ways will have underneath lighting. The lighting location is to be determined by the District Design Unit.

COLORADO DEPARTMENT OF TRANSPORTATION STAFF BRIDGE BRIDGE DESIGN MANUAL	Subsection: 17.4 Effective: March 6, 2000 Supersedes: October 9, 1998
OVERHEAD SIGNS AND MAST ARM SIGNALS	

#### 17.4.1 PROJECT PROCEDURES

The need for sign and signal structures should be established as early as possible in the design process. If standard or special overhead signs or mast arm signals are to be used on a project, a structural engineer must be assigned to them. Special designs are made to accommodate large panels, mast arms longer than 50 feet, and variable message sign (VMS) boxes. The structural engineer can be a CDOT or a consultant employee. In either case, it is important that adequate time be scheduled for the assigned structural engineer to do the required work.

The sign and signal work shall include the following:

1. Determine whether CDOT sign and signal standard drawings can be used without a special design. If not, provide a special design.
2. For overhead sign structures, obtain a structure number from the Bridge Management Unit by calling (303) 757-9187.
3. Seal the plan sheets for all special designs.
4. Check the shop drawings for all signs and for special signal work.

The current CDOT sign and signal standards are pre-sealed documents and do not need to be sealed for individual projects. All special signs and signals must be designed and sealed on an individual basis. A structural engineer shall be assigned to each project to determine if a special design is required and to check the shop drawings.

#### 17.4.2 MINIMUM DESIGN REQUIREMENTS

The design of sign and signal supports shall be in conformance with the current issue of the AASHTO Standard Specifications for Structural Supports for Highway Signs, Luminaires, and Traffic Signals and National Cooperative Highway Research Program (NCHRP) Report 412.

NCHRP Report 412 shall be used to address fatigue issues on sign bridges (with or without VMS boxes) even though the report focuses on cantilevered signals, signs and light supports. Regardless of the structure type, the allowable stress range for main members at the tips of stiffeners as called for in Details 21 and 22 of Figure 1.9.6.1 in the Fatigue Guide shall be 11 ksi based on CDOT field observations. Use importance factors of 1.0 for the design of all CDOT overhead sign and mast arm signal structures.

Sign and signal structures shall be placed at right angles (within 10 degrees) to approaching motorists. All sign and some signal supports located within the clear zone must be shielded with a crashworthy barrier. If a barrier is used, or is required, the sign or signal structure shall be located just beyond the design deflection distance of the barrier to minimize the required span length.



### 17.4.3 BRIDGE-MOUNTED SIGN STRUCTURES

#### 17.4.3.A DESIGN CONSIDERATIONS

Design loads for sign structure supports shall be calculated by assuming an 8 ft deep sign over the entire roadway width under the sign structure. This will account for any signs that may be added in the future. Loads from the sign structure shall be included in the design of the bridge. See subsection 17.4.2 for other design information.

#### 17.4.3.B GEOMETRICS

Bridge-mounted sign structures shall be avoided wherever possible. If this cannot be done, the sign shall be located as close to a pier support as is practical. Signs shall be aligned parallel to the bridge if the skew angle is 80 degrees or more. Otherwise, the signs shall be set perpendicular to the traveling lanes underneath. For a horizontally curved roadway, signs shall be placed perpendicular to a chord intersecting the curve at a point 350 feet ahead of the sign location. The bottom of a luminaries or sign shall be placed 6 inches above the bottom of the fascia girder. The minimum vertical clearance for bridge mounted sign structures shall be 16'-6".

#### 17.4.3.C AESTHETICS

Signs shall be mounted on bridges with the following in mind:

1. Preferably, the top of the sign and its support should not project above the bridge rail.
2. Whenever possible, the support structure should be hidden from view as seen by traffic on the lower roadway when viewed from a distance.
3. The sign support shall be detailed in such a manner that it will permit the sign and lighting bracket to be installed level.
4. When the sign support will be exposed to view, care shall be taken in determining member sizes and connections to provide the best possible appearance.

#### 17.4.3.D SIGN PLACEMENT

Whenever possible, the designer should avoid locating signs under bridge overhangs which could cause partial shading or partial exposure to the elements. Avoid placing signs directly under structure drip-lines because such installations may result in uneven fading, discoloring and reading difficulty.

#### 17.4.3.E INSTALLATION

Expansion type concrete anchors are undesirable for attaching sign support brackets to the supporting structure because of vibration and pullout concerns. Instead, A307 or A325 bolts shall be used as through bolts or A307 all-thread rod may be used to make drilled-in-place anchor bolts bonded to the supporting concrete with an approved two-part epoxy system. Through and drilled-in-place anchor bolts can be used to resist direct tension and shear loads. The depth and diameter of drilled holes for bonded anchor bolts shall be 9 bolt diameters plus 2" and one bolt diameter plus 1/8" respectively. Bonded anchor bolts are 100% effective if the spacing and edge distance is equal to or greater than 9

bolt diameters and are considered to be 50% effective when the edge distance or spacing is reduced to 4.5 bolt diameters. Edge distances and spacings less than 4.5 bolt diameters are not allowed.

Use cast-in-place A307 J-bolts for new concrete work.

When an approved proprietary bolting system is specified, the following note shall be added to the plans:

The bolting system is to be installed using the manufacturer's recommendations.

When an approved two-part epoxy system is specified, the following note shall be added to the plans:

The two-part epoxy system shall be installed using the manufacturer's recommendations.

Torque all through bolts to the following values in ft-lbs and, for bonded anchor bolts, do not exceed the specified tension working limit in pounds for permanent dead loads:

ASTM Spec	Bolt Dia.	-- Torque --		Tens. Limit
		dry	lub	
A307	0.500"	25	20	1400
"	0.750"	85	60	3300
"	1.000"	200	150	6000
A325	0.500"	70	50	N.A.
"	0.750"	240	180	"
"	1.000"	350	265	"

Use interpolation to get torque and tension limit values for other size bolts.

With respect to allowed bolting materials, A36 may be substituted for A307 and A449 may be substituted for A325.

---

COST ESTIMATING

---

**GENERAL**

The quantity of the various materials involved in the construction of a project are needed for determining the cost of the project and to establish a base for the Contractor's bid and payment.

Quantities for determining cost estimates are required throughout the various stages of a project development, as their need arises, beginning with the conceptual studies to the completion of the final contract plans. These quantities are calculated from the best information available at the time. Quantity calculations shall in general be made during the following stages of the project development.

**CONCEPTUAL STAGE**

During the conceptual stage of the project, estimated quantities may be required to evaluate the most economical structure for the bridge site. The need for quantities will depend upon whether or not reasonable cost records are available from which an estimated square foot cost can be determined. Each Design Unit Supervisor will have a current Cost Data Book (Strip Set) that will include a square foot cost for most types of structures.

**PRELIMINARY PLAN STAGE**

Upon completion of the preliminary plan, estimated quantities shall be figured by the designer. It is his/her responsibility to arrive at a Preliminary Cost Estimate which is included in the transmittal letter sent to the appropriate parties along with the Preliminary General Layout. The designers files must include documentation of the items included in the Preliminary Cost Estimate. The estimate, at this stage of project development, shall include an amount of 15% for contingencies. Estimated unit prices will be taken from the current Cost Data Book. Either the average values or project-specific data may be used by the designer and included in his/her documentation.

**DESIGN STAGE**

As the design progresses, and refinements in the design are made, if new quantities x cost of the bid unit vary more than 10% of the total cost previously submitted with the General Layout, a new submittal shall be sent to the appropriate parties so that they may be made aware of the total cost revision.

**BID PROPOSAL STAGE**

The need for a basis for contractor bidding and payment requires that upon completion of a design project the quantity of certain materials involved in the construction of the project be computed. Bid items and their listed sequences are standardized and are set forth in the list of Standard Bid items found in the current Cost Data Book compiled by Cost Estimates Squad of the Staff Design Branch. On occasion, for special situations, a bid item may be required which is not a "Standard Bid Item".

Those bid items which involve payment based on a quantity of material require that the material for those items be calculated and shown in the plans in the Summary of Quantities Table.

COMPUTATION OF QUANTITIES

---

*RESPONSIBILITIES*

The structural design team has the responsibility to compute quantities. Each design team shall be responsible for alerting the appropriate parties when alterations are made in the design features which will affect the cost of the structure.

*PROCEDURE FOR COMPUTATION*

Quantities are to be computed and checked independently. Each person shall summarize his/her figures. See the section covering quantity calculations in the CDOT Bridge Detailing Manual. The two summaries are to be compared. In addition, the breakdown for each quantity shall be checked item by item. For example, the originator's figures for excavation for each of Piers 1, 2 and 3 should be compared separately against the corresponding figures made by the checker.

All quantities and summaries of quantities are to be filed in the job file with any subsequent revisions to these figures. All revisions shall be checked in the same manner as the original quantities. On the "Summary of Quantities" sheet, the original figure should not be erased, but crossed out and replaced by the new figure in a different colored pencil. If there are too many revisions, the old summary sheet should be marked void, left in the file and a new sheet filled out. The new summary sheet is to be marked "Revised" and dated.

This procedure makes it necessary that before making the calculations, the checker shall determine which method of breakdown the originator used for his or her calculations to facilitate checking. Mistakes in quantities can be very costly to the department.

*DATA SOURCE*

The completed design drawings are used in computing the quantities for determining the final estimated construction cost and listing in the bid proposal.

*ACCURACY*

Quantities used in the development of cost estimates during the conceptual stage of the design are expected to have an accuracy of  $\pm 10\%$ . The first iteration of quantities after the preliminary plan has been completed is expected to have an accuracy of  $\pm 5\%$ .

Final quantities to be listed on the Summary of Quantities sheet are to be calculated to have an accuracy of  $\pm 1\%$ .

*FORMAT*

The format is covered in the CDOT Bridge Detailing Manual under the section on quantity calculations. Also see CDOT Bridge Design Manual *Section 18.3*.

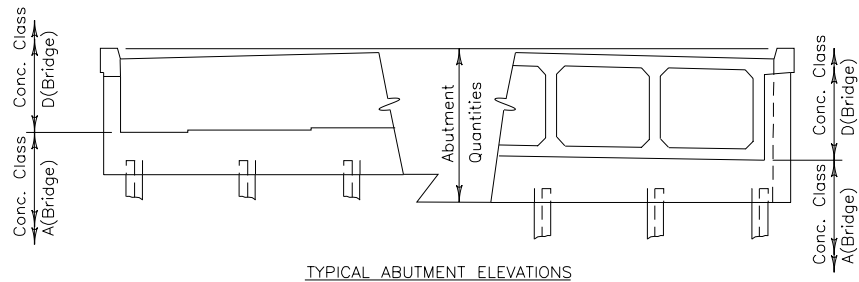

TYPICAL ABUTMENT ELEVATIONS

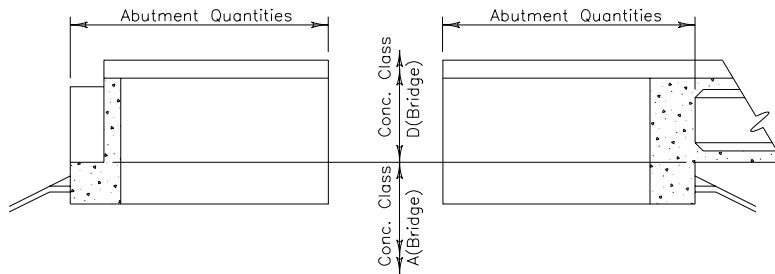

TYPICAL ABUTMENT SECTIONS & WING ELEVATIONS

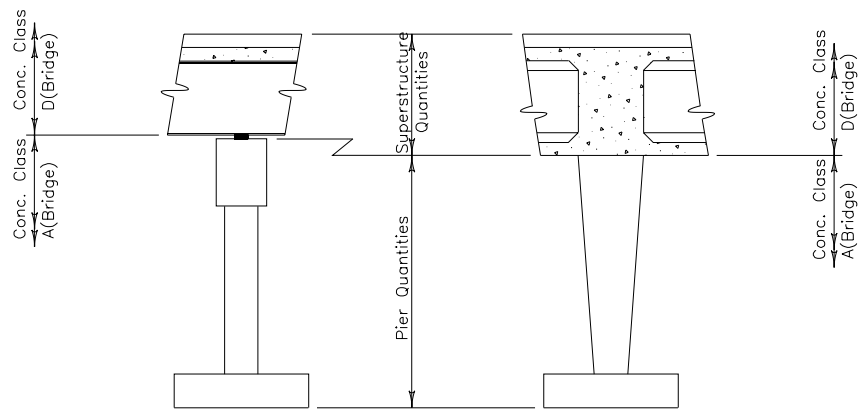

TYPICAL PIER & SUPERSTRUCTURE SECTIONS

---

BID ITEMS AND QUANTITIES

---

*BID ITEMS AND PAY UNITS*

Each bid item shown in the Summary of Quantities for Structures shall be taken from those coded and authorized by Staff Design Branch Cost Estimates Squad. Bid items are to be listed in the sequence shown in the latest edition of "Item Descriptions and Abbreviations" as compiled by the Cost Estimates Squad. For items or pay units not currently listed in the "Item Book", the Cost Estimates Squad will provide the appropriate coding sequence.

A description of the work, method of measurement and basis of payment is required for each bid item used. If this description is not given in the "Standard Specifications for Road and Bridge Construction" or a Standard Special Provision, it must be given in a Project Special Provision.

*QUANTITIES AND QUANTITY CALCULATIONS*

Two independent sets of quantities shall be calculated. Each set of quantities for each structure shall contain a quantity form filled out using proper item numbers, descriptions, and units. Differences shall be resolved and totals from the record set shall be shown in the plans. Extended totals for both sets of quantities shall be within one percent of each other, except that the totals for excavation and backfill within five percent are acceptable. Note, quantities from the two independent sets are not to be averaged.

All extended totals are to be rounded to the nearest whole unit, except timber and treated timber shall be rounded to the nearest 100 feet board measure (0.1 MFBM). Individual totals for structure elements shall be to the nearest whole unit, except concrete and timber may be shown to the nearest tenth of a unit. If necessary, adjust the element totals to agree with the rounded extended total.

Logical breaks between substructure and superstructure quantities shall be used for calculations. Such breaks may be construction joints, bearing seats, expansion devices, abutment front face, abutment back face or such breaks as indicated on the plans.

The following will be included as roadway quantities only and will not be shown on the bridge summary:

- All revetment such as slope mattress or riprap
- Excavation and backfill relating to revetment installation
- All excavation and embankment for spur dikes, channel improvements or bike paths
- Unclassified Excavation

COLORADO DEPARTMENT OF TRANSPORTATION STAFF BRIDGE BRIDGE DESIGN MANUAL	Subsection: 19.1 Effective: August 1, 2002 Supersedes: April 10, 2000
MINIMUM PROJECT REQUIREMENTS FOR MAJOR STRUCTURES	

The following presents the minimum requirements for CDOT projects which include major structures (as defined in section 19.1.8 below). This is a summary. More detailed information can be found in the standards referenced herein and other CDOT documents addressing design and construction. This summary identifies the structural staff, submittals, design and construction specifications, and project processes required for major structures.

These requirements provide for the following primary objectives when the project includes major structures.

- The minimum requirements for major structures will be similar for all projects; in-house, consultant, developer, and design-build.
- A thorough preliminary design process is required to identify the general structural solutions and the appropriate project design criteria needed to meet the Department's needs, and to help reduce costly delays and revisions during final design and construction.
- Structure final plans and specifications shall have a thorough independent quality control check by the structural design team.
- Whether or not to conduct quality assurance reviews of consultant structure design work after the FIR will be at the discretion of the Resident Engineer. Department final design reviews may be added to the contract for consultant design and design-build projects, but are not listed in this document as minimum requirements.
- Design and as-constructed documentation on major structures will be prepared and submitted to Staff Bridge for the Department's structural archives.

As pertaining to structures, any conflicts between this summary, the standards referenced herein, or any other CDOT document shall be resolved by the Staff Bridge Engineer or his designee.

Establishing CDOT's structural design policy and allowing variances to the policy is the responsibility of the Staff Bridge Engineer. It is also the responsibility of the Staff Bridge Engineer to ensure the Department's policy on major structures is clearly communicated, readily referenced, and benefits the mission of the Department. Recommendations for improvement in this regard should be communicated to either the Staff Bridge Engineer, his staff, or the Chief Engineer.

### **19.1.1 GENERAL PROJECT REQUIREMENTS FOR MAJOR STRUCTURES**

#### **19.1.1A STANDARDS**

All major structures shall be designed and constructed in accordance with the Department's structural standards as defined in section 19.1.6 of this document.

#### **19.1.1B PROJECT STRUCTURAL ENGINEER**

On projects with major structures, the design team shall include a Project Structural Engineer (see definitions). This engineer will be in responsible charge of the structural design activities and will seal the contract plans and specifications pertaining to the major structures. The Project Structural



Engineer may be either a consultant or CDOT employee. Note, in order to accomplish the independent design check discussed under 19.1.4, Final Design, the project team will also need to include, at least, a second structural engineer. This second engineer does not need to be a member of the Project Structural Engineer's staff.

#### 19.1.1C STRUCTURAL REVIEWER

On consultant design projects the design team shall include a licensed CDOT engineer with sufficient structural experience to act as the Structural Reviewer. Thorough and detailed reviews of the preliminary design submittals (as a minimum, structure selection reports and FIR plans as described below) are required. After the FIR, holding structure status meetings is the minimum requirement. Quality control is the responsibility of the Consultant Project Structural Engineer; consequently, whether or not the Structural Reviewer will conduct a quality assurance plans review after the FIR will be left to the discretion of the Resident Engineer.

#### 19.1.1D STRUCTURE STATUS MEETINGS

On consultant projects the Consultant Project Structural Engineer shall meet periodically with the CDOT Structural Reviewer to discuss the design work. Typically, these structure review meetings shall be held no less than once every two months and no more than once every two weeks. They may be held in conjunction with the general project progress meetings. Attendance by the Resident Engineer and, as appropriate, other members of the design team (e.g., geology and hydraulics) is encouraged. Holding structure status meetings for in-house design projects is also encouraged.

#### 19.1.1E EXCEPTIONS

Major structures for which the Department's M & S Standards are used (e.g., concrete box culverts and sign bridges) are excluded from the section 19.1.4 final design requirements given below. Sign bridges, cantilevers and butterflies extending over traffic are major structures but are excluded from the preliminary design sections 19.1.3.A through 19.1.3.D below as minimum requirements

The requirements in this document apply to design-build projects except the FOR activities in section 19.1.4C, and the quantity calculations under 19.1.4E.4, will not apply to the Contractor's design work.

The requirements in this document apply to developer projects (see definitions) constructed within CDOT right-of-way except for the scoping requirements in 19.1.2, and the preliminary design activities related to determining minimum construction costs (section 19.1.3B.8 primarily). FIR and FOR level submittals are generally expected, but whether or not to hold formal meetings will be at the discretion of the Resident Engineer. Field packages and construction engineering assistance (Sections 19.1.4E.4, 19.1.5A, and 19.1.5B) are not CDOT requirements if the Developer performs the construction engineering.

**19.1.2 PROJECT SCOPING FOR MAJOR STRUCTURES****19.1.2A SCOPING**

The Program Engineer and Resident Engineer will determine when to involve structural engineering staff in the project scoping. To prevent later changes to the project scope, the Department's structural employees should be involved in any scoping involving major structures. When the project involves existing structures, the information available from Staff Bridge on these structures shall be utilized.

On consultant projects, the contract Scope of Work shall be reviewed by CDOT's Structural Reviewer and the Consultant's Project Structural Engineer prior to signing the consultant's contract. The structure activities in the Scope of Work shall be consistent with the requirements outlined in this document.

**19.1.2B SCHEDULE AND WORKHOUR ESTIMATES**

When preparing schedules and workhour estimates, the Resident Engineer shall obtain estimates for the major structure activities from the Project Structural Engineer on in-house jobs, or the Structural Reviewer on consultant jobs. The Resident Engineer will establish the final schedule and work hours, however this decision is not to be made independent of information received from the CDOT structural team member. Early in the project, if the CDOT Project Structural Engineer or Structural Reviewer is not known, then an employee who may potentially act in this capacity for the project will be assigned to prepare the estimates.

**19.1.2C PROJECT SURVEY REQUEST**

The Project Structural Engineer should participate in developing the project survey request to determine if any project specific modifications to the basic information required by the Department's Survey Manual are necessary.

**19.1.3 MAJOR STRUCTURE PRELIMINARY DESIGN**

The preliminary design for major structures shall be conducted as outlined below to ensure the Department obtains a structure layout and type selection which achieves the project's objectives and minimizes revisions during the final design and construction phases. The structure selection report presents the results of the preliminary design process. The report shall document, justify and explain the Project Structural Engineers' structure layout and type selection.

All of the following topics should be considered for design-build projects, but the preliminary design shall be developed only to the extent necessary to define the Department's minimum project requirements for the structures and establish probable construction costs.

The Project Structural Engineer will be responsible for conducting the following activities.

**19.1.3A STRUCTURE DATA COLLECTION**

1. *Obtain the structure site data:* The following data, as applicable, shall be collected (see Procedural Directive 1905.1): Typical roadway section; roadway plan and profile sheets showing all alignment data, topography, utilities,

preliminary drainage plan, and right-of-way restrictions; preliminary hydraulics information; preliminary geology information; environmental constraints; lighting requirements; guardrail types; conceptual recommendations for structure type; and architectural recommendations.

2. *Obtain data on existing structures:* When applicable, collect items such as existing plans, inspection reports, structure ratings, foundation information, and shop drawings. A field investigation of existing structures will be made, with notification of the Resident Engineer.

#### 19.1.3B STRUCTURE LAYOUT AND TYPE STUDY

1. *Review the structure site data* to determine the requirements that will control the structure size, layout, type, and rehabilitation alternatives. On a continuing basis provide data and recommendations to other members of the design team (e.g., roadway, hydraulics, survey) to help finalize the structure site data.

2. *Determine the structure layout alternatives.* Determine the structure length, width, and span configurations that satisfy all horizontal and vertical clearance criteria. Working with the roadway designer, determine the necessary length of walls, and the top and bottom of wall profiles.

3. *Determine the rehabilitation alternatives.* Continued use of all or parts of existing structures shall be considered as applicable. The structural and functional adequacy of existing structures shall be investigated and reported on. Determine the modifications and rehabilitation necessary to use all or parts of existing structures and the associated costs.

4. *Determine the structure type alternatives.* Consider precast and cast-in-place concrete and steel superstructures and determine the spans and depths for each. For walls, determine the feasible wall types as discussed in CDOT Bridge Design Manual Section 5.

5. *Determine the foundation alternatives.* Consider piles, drilled shafts, spread footings, and mechanically stabilized earth foundations based on geology information from existing structures and early estimates from the project geologist. To obtain supporting information, initiate the foundation investigation as early as possible during the preliminary design phase.

6. *Develop the staged construction phasing plan,* as necessary for traffic control and detours, in conjunction with the parties performing the roadway design and traffic control plan. The impact of staged construction on the structure alternatives shall be considered and reported on.

7. *Compute preliminary quantities and preliminary cost* estimates as necessary to evaluate and compare the structure layout, type, and rehabilitation alternatives. Do not use square foot or relative cost estimates to select the final structure layout and type; i.e., compute the bid item quantities for the substructures and superstructures for each alternative in accordance with Subsections 18.2 and 18.3 and determine the cost for each of them in accordance with the requirements in Subsection 18.1. Square foot and relative cost estimates are to be used for conceptual design work only.

8. *Evaluate the structure alternatives.* Establish the criteria for evaluating and comparing the structure alternatives that encompass all aspects of the project's objectives. Elements typically considered include safety,

construction cost, constructability, life cycle costs (durability), environmental considerations, aesthetics, in service maintenance and inspection, and the ability to rehabilitate, widen and replace the new structure. Based on this criteria, select the optimum structure layout, type, and rehabilitation alternatives, as applicable, for recommendation. In the case of design-build, select the set of suitable structure alternatives.

9. *Prepare preliminary general layout* for the recommended structure. Prepare the structure layout in accordance with the CDOT Bridge Detailing Manual. Obtain a structure number from Staff Bridge to show on the layout. Special detail drawings shall accompany the general layout where appropriate. Perform the independent design check of the general layout.

#### 19.1.3C STRUCTURE SELECTION REPORT

*Prepare a structure selection report* to document, and obtain approval for, the structure preliminary design. By means of the structure general layout with supporting drawings, tables, and discussion, provide for the following as applicable:

1. Summarize the structure site data used to select and lay out the structure. Include the following:

- Project site plan
- Roadway vertical and horizontal alignments and cross sections at the structure.
- Existing structure data, including sufficiency rating and, for HBRRP (the FHWA highway bridge replacement and rehabilitation program) projects, whether or not the structure is on the Federal Select List.
- Construction phasing.
- Utilities on, below, and adjacent to the structure.
- Hydraulics: Channel size and skew, thalweg elevation, design year frequency, minimum low girder elevation, design year and 500 year high water elevations, estimated design year and 500 year scour profiles, and channel scour protection.
- Environmental constraints.
- Preliminary geology information for structure foundations.
- Architectural requirements.

2. Report on the structure layout and type selection process. Include the following:

- Discuss the structure layout, type, and rehabilitation alternatives considered.
- Define the criteria used to evaluate the structure alternatives and how the recommended structure was selected.
- Identify any deviations from the Department's structural standards as defined in section 19.1.6 of this document.
- Provide a detailed preliminary cost estimate and general layout of the recommended structure, or, for design-build, set of suitable structures.

3. *Submit the report for review and comment* by the project design team to obtain acceptance of the recommended structure type and its layout. Allow at least two weeks for review. A copy of the structure selection report shall be submitted to the Staff Bridge Preconstruction Engineer, and on Federal Aid projects and projects on the National Highway system, to the FHWA Division Bridge Engineer. The associated general layout, with the revisions resulting

from the review, will be included in the FIR plans. The work schedule shall be planned accordingly.

#### 19.1.3D FOUNDATION INVESTIGATION REQUEST

*Initiate the foundation investigation* as early in the preliminary design phase as practical. On plan sheets showing the project control line, as well as any utilities, identify the test holes needed with stations and coordinates and submit them to the project geologist. The available general layout information for the new structure shall be included in the investigation request.

#### 19.1.3E FIR

On obtaining initial approval for the structure type selection and layout, the Project Structural Engineer shall submit the general layout for inclusion in the FIR plans. After the FIR the general layout shall be revised as needed. Final approval from the Resident Engineer of the revised general layout shall be obtained before proceeding with final design.

#### 19.1.4 MAJOR STRUCTURE FINAL DESIGN

The Project Structural Engineer will be responsible for conducting the following activities after the FIR.

##### 19.1.4A STRUCTURAL DESIGN AND PREPARATION OF PLANS AND SPECIFICATIONS

1. Perform the structural analysis and design. Document the work with design notes, detail notes and computer output. The Engineer is responsible for the meaning and applicability of all computer generated information.

2. Update the general layout, as necessary, as final design information is received from the other disciplines. Keep the design team apprised of any changes. Obtain the final geology and hydraulics reports early in the design process.

3. Prepare all detail drawings in accordance with the CDOT Bridge Detailing Manual and Bridge Design Manual. Obtain the current standard worksheets and specifications from Staff Bridge.

4. Prepare the special provisions applicable to the project. The Project Structural Engineer shall provide the special provisions applicable to the major structures.

5. Compute the quantities and complete the summary of quantities.

##### 19.1.4B INDEPENDENT DESIGN, DETAIL, AND QUANTITY CHECK

1. Perform independent design and detail checks (see definitions) of the plans and special provisions. The Engineer is responsible for the meaning and applicability of all computer generated information.

2. Revise all plan sheets, special provisions and design notes to correct any deficiencies found in the design and detail checks.

3. Perform an independent check of quantities and revise the summary of quantities as necessary.

**19.1.4C FOR**

Complete structural plans and special provisions shall be submitted for inclusion in the FOR plan set. The Project Structural Engineer shall review the FOR plans to verify design information received from the other disciplines, and attend the FOR to obtain review comments on the structural design. After the FOR the plans and specifications shall be revised as needed and submitted for inclusion in the final plan set.

**19.1.4D BRIDGE RATING AND FIELD PACKAGES**

Prepare the rating packages in accordance with the CDOT Bridge Rating Manual. Prepare the structure field packages in accordance with the CDOT Bridge Detailing Manual.

**19.1.4E FINAL DESIGN SUBMITTAL**

When the final plans and specifications are submitted to the Resident Engineer, the Project Structural Engineer shall submit to the Staff Bridge records unit an independent set of the following for each major structure. A copy of the Field Package should be submitted directly to the Resident Engineer by the Project Structural Engineer.

1. A final submittal letter certifying that the structural plans and specifications have been prepared in accordance with the current design standards of the Colorado Department of Transportation.
2. The complete set of final design notes for each bridge, overhead sign structure and retaining wall (including output from computer programs). These notes shall include revisions reconciling any differences between the original design, the independent design check and any design changes resulting from subsequent reviews.
3. The complete set of final independent design check notes for each bridge, overhead sign structure and retaining wall.
4. A Field Package for each bridge: The final set of the final quantity calculations as described in the CDOT Bridge Detailing Manual, and a copy of the geology report. When the project involves the replacement, widening, or rehabilitation of an existing structure, the as-constructed plans of the existing structure shall be included in the field package. The set of quantity calculations is not required for the Contractor design work on design-build projects.
5. A Rating Package for each bridge: Rating summary sheet for girders and deck, rating information and hand calculation sheets, rating computer output, and electronic copy of rating input file. Refer to the Bridge Rating Manual for a description of these items.

**19.1.5 MAJOR STRUCTURE CONSTRUCTION****19.1.5A ASSISTING THE PROJECT ENGINEER**

The Project Structural Engineer shall be available to the construction Project Engineer for assistance in interpreting the structure plans and specifications, and for resolving construction problems related to the structure. Any changes

or additions to the structure, as defined in the contract documents, shall be communicated to the Project Structural Engineer.

#### 19.1.5B OUTSIDE INQUIRIES

After project advertisement, any inquiries from contractors, suppliers or the media regarding the structural plans and specifications shall be responded to through the Project Engineer unless approval is obtained from the Project Engineer to do otherwise. This applies to all CDOT employees and any consultants that were part of the design process.

#### 19.1.5C CONTRACTOR DRAWING SUBMITTALS

The Project Structural Engineer for a given structure shall review any shop drawings submitted for that structure. This includes Contractor designed modifications or alternates to the structure. At the Project Engineer's request, the Project Structural Engineer will assist in interpreting Contractor working drawing submittals. Staff Bridge shall receive a copy of all contractor drawing submittals for archiving.

#### 19.1.5D AS CONSTRUCTED PLANS

The Project Engineer shall document the final dimensions and details of the completed structure on the original plan sheets and submit them to Staff Bridge for archiving.

### **19.1.6 STANDARDS FOR THE DESIGN AND CONSTRUCTION OF STRUCTURES**

This is not a list of general references, but a list of required references which establish CDOT's structural design and construction requirements. Other standards are applicable as referenced by the following publications (e.g., CDOT M&S standards, CDOT Survey Manual, AREA specifications, AWS and CRSI publications, and software applications).

#### 19.1.6A CDOT STANDARDS PUBLISHED BY STAFF BRIDGE

- \* CDOT Bridge Design Manual
- \* CDOT Bridge Detailing Manual
- \* CDOT Bridge Rating Manual
- \* Staff Bridge Technical Memorandums
- \* Staff Bridge Project Special Provisions
- \* CDOT Staff Bridge Worksheets (standard drawings)

#### 19.1.6B CDOT STANDARDS PUBLISHED OUTSIDE OF STAFF BRIDGE

- \* CDOT Standard Specifications for Road and Bridge Construction
- \* CDOT Supplemental Standard Specifications for Construction
- \* CDOT Standard Special Provisions
- \* CDOT Design Manual
- \* CDOT Construction Manual

#### 19.1.6C STANDARDS PUBLISHED OUTSIDE OF CDOT

- \* AASHTO LRFD Bridge Design Specifications
- \* AASHTO Standard Specifications for Highway Bridges
- \* AASHTO Guide Specifications for Design of Pedestrian Bridges
- \* AASHTO Guide Specifications for Horizontally Curved Highway Bridges

- \* AASHTO Manual for Condition Evaluation of Bridges
- \* AASHTO Guide Specifications for Design and Construction of Segmental Concrete Bridges
- \* AASHTO Standard Specifications for Structural Supports for Highway Signs, Luminaries and Traffic Signals
- \* AASHTO Guide Specifications for Structural Design of Sound Barriers

#### 19.1.7 MAJOR PROJECT MILESTONES

The following is a list of the major milestones to be used for scheduling the project structural activities for major structures. These are only the major milestones. Other activities and submittals critical to the success of the structural work are not shown; e.g. the submittal of traffic, utility and environmental information to the structural design team. Project start-up activities such as scoping, scheduling and making the survey request are also important to the timely completion of quality structural work, but are not shown below. The hydraulic submittals shown apply to waterway crossings.

Roadway submittal to structure team

Preliminary Hydraulics submittal to structure team

Foundation investigation request by structure team

Submittal of structure selection report

Submittal of structure FIR plans

FIR

Final hydraulics submittal to structure team

Final geology report to structure team

Submittal of structure FOR plans and specifications

FOR

Final structure plans and specifications submittal to the Resident Engineer

Final structure design submittal to Staff Bridge's records unit

Submittal of as-constructed plans to Staff Bridge's records unit

#### 19.1.8 DEFINITIONS

**Major Structures:** Major structures are bridges and culverts with both a total length greater than 6 m (20'), and retaining walls with both a total length greater than 30 m (100') and a maximum exposed height at any section of over 1.5 m (5'). The length is measured along centerline of roadway for bridges and culverts, and along the top of wall for retaining walls. Overhead sign structures (sign bridges, cantilevers and butterflies extending over traffic) are also major structures. During preliminary design a structure number shall be obtained from Staff Bridge. This number should be used on all subsequent correspondence and plan sheets to identify the structure



**Project Structural Engineer:** A licensed professional engineer (by the State of Colorado), with structural design experience, acting in responsible charge for the design work of a major structure. Other than the sealing of plans and specifications, the activities described in this document pertaining to the Project Structural Engineer may be executed by his or her designee. The Project Structural Engineer may be a consultant or CDOT employee. There may be more than one Project Structural Engineer on a project as in the case when there is more than one structural design team working on separate major structures, or for design-build where the Contractor will have a Project Structural Engineer for the Contractor's portion of the structural design work.

**Structural Reviewer:** A CDOT employee with a professional engineer license and structural design experience. This employee will be responsible for the Department's structural design reviews on a consultant project. Although there should be only one Structural Reviewer on a project (to obtain uniformity in directions to consultants or projects with more than one major structure) the activities described in this document pertaining to the Structural Reviewer may be executed by his or her designee.

**Project Engineer:** As defined in CDOT's Standard Specifications for Road and Bridge Construction, the Chief Engineer's authorized representative who is responsible for the administration of a given construction contract.

**Resident Engineer:** The CDOT employee who is responsible for the administration of a project. With the Department's re-engineering program, the preconstruction project manager and the construction Project Engineer will either be the Resident Engineer or the Resident Engineer's designee.

**Program Engineer:** As defined by the Department's re-engineering program, the immediate supervisor of the Resident Engineer.

**Independent Check:** The verification of the contract documents by a person or party separate from those who prepared the documents. This key quality control requirement involves the complete verification of all design work, details, specifications and quantities to ensure structural integrity, constructability, and that all the standards listed in section 19.1.6 have been satisfied. As such, the independent check results in two sets of complete design and quantity calculations, and a review set of the final plans where all the information has been verified.

**Design Review:** A quality assurance review of selected portions of the contract documents to verify that the designers' quality control procedures have been implemented. A design review involves little to no calculations and does not ensure that structural members have been sized or detailed sufficiently for structural integrity, constructability, or satisfaction of the standards listed in Section 19.1.6.

**Developer Project:** A construction project within CDOT right-of-way sponsored and funded by either a private or public entity other than CDOT.

CONTRACTOR DRAWING SUBMITTALS

---

**19.2.1 GENERAL**

There are two type of contractor drawing submittals, shop drawings and working drawings. Shop Drawings (6 sets minimum) are submitted for formal review and are returned to the contractor. Working drawings (2 sets minimum) are not formally reviewed nor returned to the contractor. Subsection 105.02 of the CDOT Standard Construction Specifications provides a guide for which type of drawing should be submitted for different structural works, and which drawings should be sealed by the contractor's professional engineer. Designers should thoroughly familiarize themselves with Subsection 105.02 of the Standard Construction Specifications.

The Department must return the shop drawings to the contractor within 4 weeks of the contractor's submittal. Designers must therefore give a high priority to the review, keeping in mind the time necessary for processing and delivery.

**19.2.2 REVIEWING SHOP DRAWINGS**

Shop drawings are reviewed to evaluate that general compliance with the information given in the plans and specifications has been achieved. The review does not extend to accuracy of dimensions, sequences, procedures of fabrication and construction, nor to safety precautions. The shop drawing review is not a complete check and does not relieve the contractor of the responsibility for the correctness of the shop drawings. The following is a guide for reviewing bridge shop drawings.

1. On the office copy, mark with a red pencil any errors or corrections. Note, only red pencil marks will be copied onto the other copies to be returned to the contractor.

2. The items to be checked are usually as follows. Check them against Contract Plans, Special Provisions, and Standard Specifications. Note, manufacturers' details may vary slightly from contract plan requirements, but must be structurally adequate and reasonable. Engineering judgement is needed.

- a. Material specifications
- b. Size of member and fasteners
- c. Length dimensions if shown on the contract plans
- d. Finish (surface finish, galvanizing, anodizing, painting, etc.)
- e. Weld size and type and welding procedure, if required
- f. Fabrication - reaming, drilling, and assembly procedures
- g. Adequacy of details
- h. Erection procedure when required by contract plans or specifications

Item i through v are specific to post-tensioning shop plans.

- i. Stand or rebar placement, jacking procedure, stress calculations, elongation's, etc., for post-tensioned members
- j. Seating loss
- k. Friction losses
- l. Time-dependent losses
- m. Steel stress plot
- n. Elongation of strands in all tendons (will be compared with the field measurements). In case of curved bridges with different web lengths, separate elongation's for each web shall be calculated where they vary more than 2 percent in exterior webs.

- o. Anchor plate size (if smaller than those called for in plans). Check bearing stress on concrete and flexural stress in plate material. Otherwise data must be (or have been) furnished to substantiate the adequacy of the anchorage's.
- p. Conduit vents at all high and low points in the spans
- q. Adequate room for the system in the concrete members. At least 50 mm (2") clear shall be provided between parallel mild reinforcing steel. The pitch on spirals in the anchorage's shall provide at least 50 mm (2") clear between adjacent bends.
- r. Interference with other reinforcement - special emphasis to be placed on this item if P/T supplier proposes a different number of tendons than shown on the plans.
- s. Offsets, from soffit to bottom of conduits. Watch for sharp curvature of tendons near end anchorage's.
- t. Strand positions in conduit in sag and summit tendon curves.
- u. Stressing sequence.
- v. Geometric details such as size of blockout

3. The following items usually do not need to be checked. However, they should be corrected, if necessary, to be consistent with other corrections.

- a. Quantities in bill of materials
- b. Length dimensions not shown on Contract Plans except for a limited amount of spot checking

4. When finished, mark the office copy with one of the following four categories, in red pencil. If in doubt between "c" and "d", check with your Supervisor. You may suggest an acceptable detail in red and mark the plans under "b", provided the detail is clearly noted: "Suggested Correction-Otherwise Revise and Resubmit".

- a. Approved, no exceptions taken
- b. Approved as noted
- c. Revise as noted Resubmit
- d. Rejected

5. If problems are encountered which may cause a delay in the checking of the shop plans, notify your supervisor and, preferably by e-mail, the Project Engineer.

6. Return 5 sets of reviewed and appropriately marked shop drawings to the Staff Bridge records unit. Alert the Project Engineer if deviations from the Contract Plans are to be allowed.

#### **19.2.3 PARTIAL SHOP DRAWING SUBMITTALS**

Unless otherwise directed by project special provisions, packages of drawings less than for a complete bridge will be accepted and dealt with as per the contract requirements of Subsection 105.02 of the CDOT Standard Construction Specifications, and the following.

The Contractor's submittal shall reflect a girder line or lines in total length or in part so long as all attachments or connections to the full or partial girder line or lines are included on the drawings. Thus, packages may be submitted which reflect the total cross-section of a bridge, including diaphragms and connections, but the submittal need not be for the full longitudinal length of the structure. The submittal shall reflect individual girder spans, or in the case of continuous girder lengths, shall reflect units between bearings and splices or between splices.

In an effort to facilitate the construction schedule, lesser submittals such as diaphragms, stiffeners, splice plates, etc., will be reviewed, if desired by the Contractor; however, they will be considered preliminary and will only be

June 1, 1998	Subsection 19.2	Page 3 of 3
--------------	-----------------	-------------

given a cursory review and no approval unless they clearly evidence the design intent. The specifications provide that the Contractor may fabricate such elements; however, prior to approval by the engineer such work is at risk.

The Contractor's submittal of shop drawings is an intermediate step between the design final drawings and specifications and the construction of a project. CDOT Standard Construction Specifications, Section 105, requires the submission of shop drawings. This requirement, therefore, presumes that such drawings are, in fact, necessary for proper execution of the work.

There is no firmly established rule as to what information belongs in the design plans and specifications and what information is to be included in the shop drawings. Typically, the design plans and specifications set forth design criteria and project requirements; whereas, the shop drawings show how the Contractor proposes to implement these criteria and requirements.

Since the project specifications require approval of the shop drawings by the designer, it is important that such drawings be submitted in sufficient details so that the designer may be assured that the drawings will result in a product which is in conformance with the intent of the design.

This Subsection, 19.2.3, is taken directly from a August 1989 memorandum from the Staff Bridge Engineer to the District 6 Construction Engineer regarding the I76-(137) project.

SELECTING BRIDGE FOR REHABILITATION OR REPLACEMENT

---

To insure that bridge replacement and rehabilitation projects utilizing HBRRP (the FHWA Highway Bridge Replacement and Rehabilitation Program) funds are selected and categorized correctly for the Five Year Plan, the following procedure is established.

1. During development of the Five Year Plan for HBRRP projects, eligible structures will be listed in two categories:
  - (a) Sufficiency rating less than 50.
  - (b) Sufficiency rating greater than 50 and less than 80.
2. When the list of eligible structures is transmitted to the District Engineer the transmittal letter shall define the structures in category (a) as eligible for replacement, and the structures in category (b) as eligible for rehabilitation. The letter shall include instructions that the structures in category (b) can be replaced only if they meet the following conditions, as approved by the FHWA Division Administrator on a case by case basis:
  - 1) Structure type makes rehabilitation impossible, or
  - 2) existing conditions would be sacrificed by rehabilitation, or
  - 3) the cost of rehabilitation would exceed the cost of replacement.
3. The HBRRP funding selections made by the District Engineers shall be sent to the Staff Bridge Branch. Staff Bridge will then review the selections for consistency with the HBRRP program criteria. Staff Bridge will discuss its comments on the Districts' selections with the District Engineers.
4. The final approved list of projects will be forwarded by Staff Bridge to the Division of Transportation Development for inclusion in the Five Year Plan.
5. The District engineers will be advised that if during the development of a rehabilitation project it becomes apparent that a structure's deficiencies cannot reasonably be corrected by rehabilitation, then Staff Bridge shall be consulted. The FHWA will be immediately notified. Together, Staff Bridge and the District Engineer will review the facts and develop supporting documentation for submission to FHWA for approval.

COORDINATION WITH HYDRAULICS DESIGN UNIT

---

The following procedures were developed in December 1991 by a Staff Bridge and Staff Design joint committee to improve the coordination between bridge and hydraulics designers on projects with major structures.

The bridge design unit leader, bridge designer and hydraulics designer will hold a short meeting after the hydraulics designer has completed a preliminary hydrology and is prepared to make a site review. They will coordinate a time for the bridge and hydraulics designers to visit the site.

Items to be discussed during the site review can include any or all of the following:

- Type of structures that are appropriate and why
- Channel size
- Debris conditions, freeboard
- Possible pier locations
- Skew
- Scour
- Flow orientation
- Any other feature or constraint that appears relevant

A joint memo will be prepared by the hydraulics designer and sent to the project manager relaying the concerns, conclusions or issues that are discussed.

The benefits of a joint site review include early discussion of the site by the two disciplines, deepening knowledge of the other discipline's concerns and presenting a joint discussion to the District roadway designers.

The bridge, hydraulics, and geology engineers should meet to discuss scour. This meeting should be initiated by the geologist soon after the borings are taken and prior to submittal of the foundation report.

This meeting will enhance a multi-discipline approach to scour determination, and accelerate the process of getting the bridge hydraulics report to the bridge designer.

The original, and a copy of, the bridge hydraulics report should be sent to Staff Bridge. The copy shall be addressed to the Staff Bridge Engineer and the Staff Bridge Preconstruction Engineer and the original addressed to the bridge design unit leader.

Attached is a Hydraulics work flow chart for major structures.

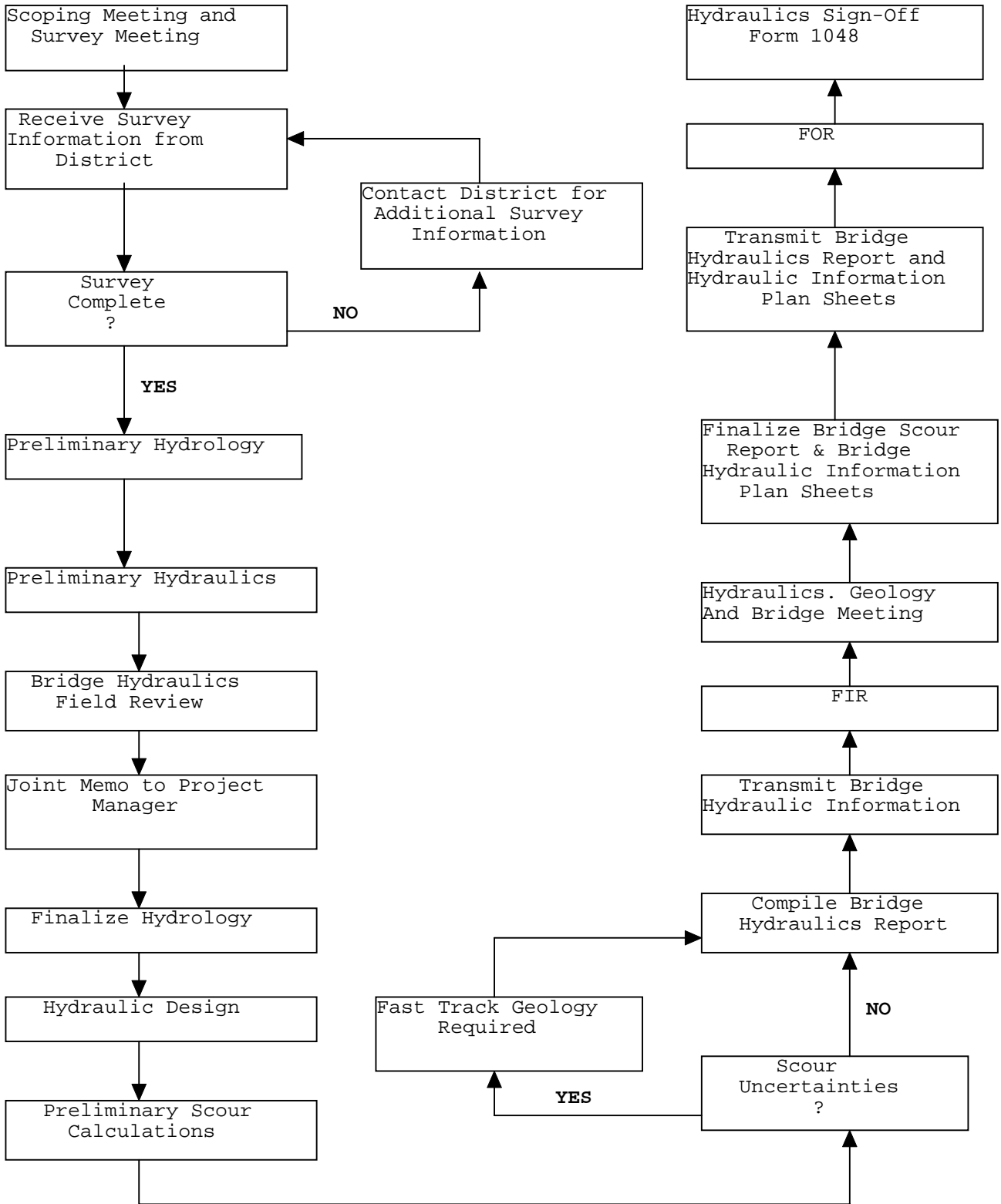

COLORADO DEPARTMENT OF TRANSPORTATION STAFF BRIDGE BRIDGE DESIGN MANUAL	Subsection: 19.5 Effective: April 10, 2000 Supersedes: January 1, 1990
OVERLAYS	

When the Region requests an overlay on an existing bridge deck that is to remain in place, the project structural engineer shall do the following:

1. Check the Inventory, Operating and Sufficiency Ratings in the structure folder to see how they will be affected by the proposed overlay.
2. Check the latest bridge inspection report to see that the deck does not exceed 4" of overlay for bridges built prior to January of 2000 and 3" for bridges designed and built thereafter. The 4" thickness is a maximum limit and should be reduced to 3" when it will not cause drainage or grade problems and will not result in an overlay thickness of less than 2" over existing features like asphalt planks and deck joints.
3. Using the criteria in Subsection 2.1, check to see that the overlay will not adversely affect the bridge rail height as measured above the finished roadway surface.

Before any overlay is utilized on an existing bridge deck, a thorough investigation of the condition of the existing deck should be conducted. A cost analysis should be made to arrive at the most cost effective solution whether it be to repair the deck and overlay it, or to replace it.