

ULTRASEAL XP

ACTIVE POLYMER WATERPROOFING SYSTEM



ULTRASEAL XP ACTIVE POLYMER WATERPROOFING SYSTEM

CONTENTS

WHAT IS ULTRASEAL XP?
PRODUCT DESCRIPTION
ASSOCIATED SYSTEM PRODUCTS
ACCESSORIES
LIMITATIONS

INSTALLATION GUIDELINES

SECTION 1: UNDERSLAB INSTALLATION

- 1.1 Substrate Preparation
- 1.2 Installation
- 1.3 Pile Caps & Grade Beams
- 1.4 Slab Penetrations
- 1.5 Elevator Pits
- 1.6 Edge of Slab, Backfilled Walls
- 1.7 Edge of Slab, Property Line Walls

SECTION 2: PROPERTY LINE CONSTRUCTION

- 2.1 Property Line Installation Guidelines
- 2.2 Soldier Pile & Lagging
- 2.3 Metal Sheet Piling Retaining Wall
- 2.4 Earth Formed Shotcrete Retention
- 2.5 Auger Cast Caisson Retention Wall

SECTION 3: BACKFILLED WALLS

- 3.1 Surface Preparation
- 3.2 Installation
- 3.3 Backfilled Wall Penetrations
- 3.4 Terminations
- 3.5 Masonry Block Walls

SECTION 4: SPECIAL CONDITIONS

- 4.1 Precast Concrete Construction
- 4.2 Contaminated Conditions

THIS MANUAL CONTAINS THE INSTALLATION GUIDELINES FOR THE ULTRASEAL XP WATERPROOFING SYSTEM FOR CAST-IN-PLACE CONCRETE APPLICATIONS, INCLUDING UNDERSLAB, PROPERTY LINE WALLS, AND BACKFILLED WALLS. THIS MANUAL DOES NOT COVER SHOTCRETE, MASONRY BLOCK, OR PRECAST CONCRETE APPLICATIONS. FOR APPLICATIONS NOT COVERED IN THIS MANUAL, CONTACT CETCO FOR SPECIFIC INSTALLATION GUIDELINES. BEFORE INSTALLATION, READ THIS MANUAL TO GAIN FAMILIARITY WITH SPECIFIC PROCEDURES AND APPLICATIONS. IN THIS MANUAL ILLUSTRATIONS ARE NOT SHOWN TO SCALE.

WHAT IS ULTRASEAL XP?

ULTRASEAL XP is the latest innovation in active waterproofing. This advanced polymer technology provides exceptional performance in a wide-range of ground contaminates—including high-saline conditions. In addition, the durable geomembrane makes ULTRASEAL XP is 10 times less permeable than traditional hydrophilic membranes. The swelling action of the XP layer can also self-seal small concrete cracks caused by ground settlement and concrete shrinkage. And most importantly, it has been proven effective in both hydrostatic and non-hydrostatic conditions. ULTRASEAL XP can be installed directly to green concrete and in extreme temperatures, thus providing greater flexibility to the construction schedule.

PRODUCT DESCRIPTION

ULTRASEAL XP is a composite membrane consisting of a XP Technology layer integrally bonded to a high-strength geomembrane. ULTRASEAL XP is designed for backfilled foundation walls, earth-covered structures, and property line construction. Property line construction applications include soldier pile and lagging, metal sheet piling, auger cast caisson, shotcrete, and stabilized earth retention walls. ULTRASEAL XP is intended to provide waterproofing protection for structural concrete surfaces under continuous or intermittent hydrostatic pressure; including high-saline and contaminated ground water conditions.

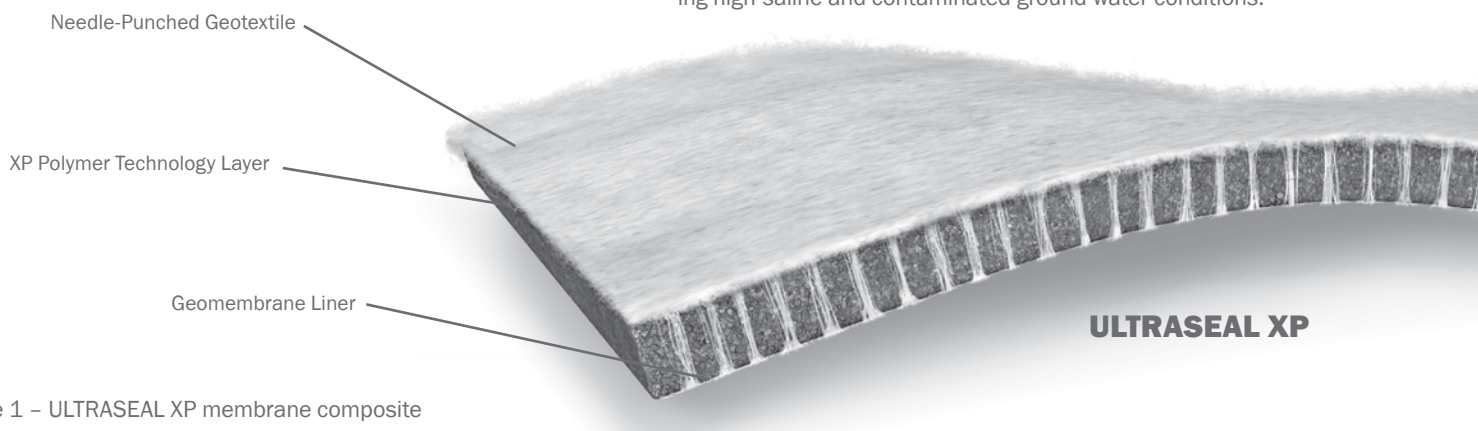

Figure 1 – ULTRASEAL XP membrane composite

Installation of ULTRASEAL XP is fast and easy. Simply position the product into place and fasten. ULTRASEAL XP can be installed on green concrete, in virtually any weather, without the need for primers or adhesives. It can be easily cut on site to form around corners and penetrations. The result is always a consistent self-sealing membrane.

ADVANTAGES

Compared to traditional active waterproofing products, ULTRASEAL XP is lighter, more impervious, and more resistant to contaminated water conditions. ULTRASEAL XP rolls are lightweight and easy to handle. Despite the lighter weight, the XP Technology is one order of magnitude less permeable than bentonite, meaning that it will deliver tenfold performance increase under most conditions. Finally, ULTRASEAL XP has improved performance in salt water conditions over bentonite waterproofing membranes.

SUPERIOR ADHESION

When concrete is poured against ULTRASEAL XP, a tenacious mechanical bond is created with the membrane composite. The mechanical bond will hold ULTRASEAL XP in intimate contact with the concrete should any ground settlement occur, thereby preventing water migration between the waterproofing and the concrete.

COST EFFECTIVE AND TIME EFFICIENT

ULTRASEAL XP is designed to be installed on a properly prepared subgrade, without the need to pour a working slab. The product's inherent flexibility allows for easy installation. ULTRASEAL XP can be installed as soon as the forms are removed; there is no waiting for the concrete to cure before installing the waterproofing.

ASSOCIATED SYSTEM PRODUCTS

WATERSTOP-XP® - expanding concrete joint WATERSTOP used around penetrations and applicable concrete joints. Swells upon hydration.

AQUADRAIN® - foundation drainage composite consisting of a molded profile core and a filter fabric. Includes sheet drainage and base drain collection.

CEMENTITIOUS BOARD: 12 mm (½") thick cementitious wall board for protection of waterproofing during the removal of steel soldier pile cap and top lagging boards.

ACCESSORIES

SEAL-X® XP - trowel grade mastic used to detail around penetrations, corner transitions and terminations.

CETSEAL - single-component polyether general sealant and adhesive
SEAMTAPE® - premium tape used to seal overlapped membrane edges of ULTRASEAL XP.

AKWASWELL® - caulk grade hydrophilic WATERSTOP.

TERMINATION BAR - Min. 25 mm (1") wide aluminum or stainless steel bar with pre-punched holes on 300 mm (12") centering for fastening.

ENVIROSHEET - self-adhering flashing membrane used for grade and thru-wall flashing.

TB-BOOT - pre-formed, single piece cover for tie-back heads and soil nails. Three sizes available: TB-6SN, TB-8 & TB-10.

LIMITATIONS

ULTRASEAL XP should only be installed after substrate preparation has been properly completed and is suitable to receive the waterproofing system. Concrete work should use conventional cast-in-place forms that produce a smooth surface. Do not use stay-in-place concrete forming; use removable forming products only.

ULTRASEAL XP is designed for below-grade waterproofing applications where the product is properly confined. ULTRASEAL XP should not be installed in standing water or over ice. If ground water contains strong acids, alkalis, or is of a conductivity of 2,500 µmhos/cm or greater, water samples should be submitted to the manufacturer for compatibility testing.

ULTRASEAL XP is designed for use under reinforced concrete slabs 100 mm (4") thick or greater on a compacted earth/gravel substrate. ULTRASEAL XP requires a minimum 150 mm (6") thick reinforced concrete slab if installed over a mud slab. ULTRASEAL XP is not designed for split-slab plaza deck construction.

ULTRASEAL XP is capable of bridging typical shrinkage cracks in concrete up to 1.5 mm (1/16").

ULTRASEAL XP is not designed to waterproof expansion joints. Consult CETCO for special installation guidelines that apply to shotcrete and precast concrete construction.

ULTRASEAL XP ACTIVE POLYMER WATERPROOFING SYSTEM

INSTALLATION GUIDELINES

Before installing ULTRASEAL XP read this installation manual to gain familiarity with specific procedures and applications. For applications not covered in this manual, contact CETCO for specific installation guidelines.

SECTION 1 UNDERSLAB INSTALLATION

ULTRASEAL XP is engineered for use under reinforced concrete slabs 100 mm (4") thick or greater on a compacted earth/gravel substrate. ULTRASEAL XP requires a minimum 150 mm (6") thick reinforced concrete slab if installed over a mud slab.

For hydrostatic conditions, ULTRASEAL XP should be installed under footings and grade beams as shown in Figures 1.6, 1.7 and 1.8. For non-hydrostatic conditions, ULTRASEAL XP should be installed around footings and grade beams as shown in Figures 1.9, 1.10 and 1.11.

Prior to installing ULTRASEAL XP the substrate must be properly prepared. Complete all required elevator pit, sump pit, grade beam and piling work prior to installing ULTRASEAL XP under main slab area. These areas must be correctly tied into the underslab waterproofing to form a monolithic seal.

1.1 SUBSTRATE PREPARATION

Substrate may be concrete, earth, sand, or crushed stone. Earth and sand substrates should be compacted to a minimum 85% Modified Proctor density. Crushed stone should be no larger than 19 mm (¾") in size. Substrate should be smooth and without sharp deflections or pockets.

1.2 INSTALLATION

Install ULTRASEAL XP over the properly prepared substrate with the geotextile side up. Overlap all adjoining edges a minimum of 100 mm (4") and stagger sheet ends a minimum of 300 mm (12") (Figure 1.1). Nail or staple edges together as required to prevent any displacement before and during concrete placement (Figure 1.2).

When the slab is poured in sections, ULTRASEAL XP should extend a minimum 300 mm (12") beyond the slab edge (Figure 1.3). This enables ULTRASEAL XP to be properly overlapped for subsequent slab section pours. WATERSTOP-XP should be installed in all applicable slab construction joints (Figure 1.3).

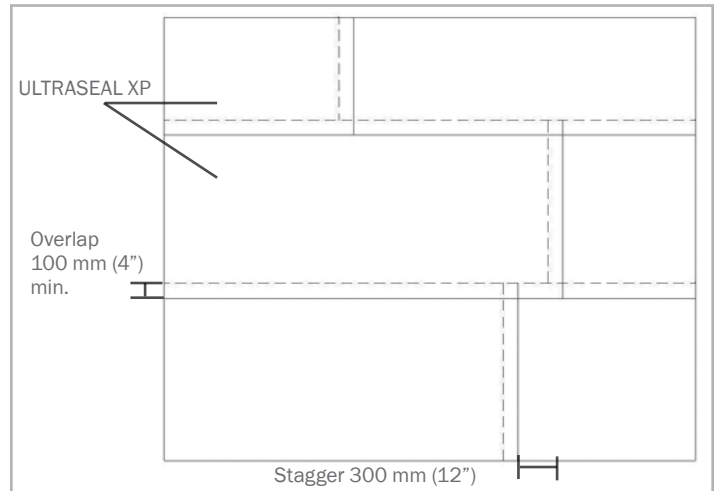

Figure 1.1 – Overlap edges 100 mm (4") with seams staggered 300 mm (12")

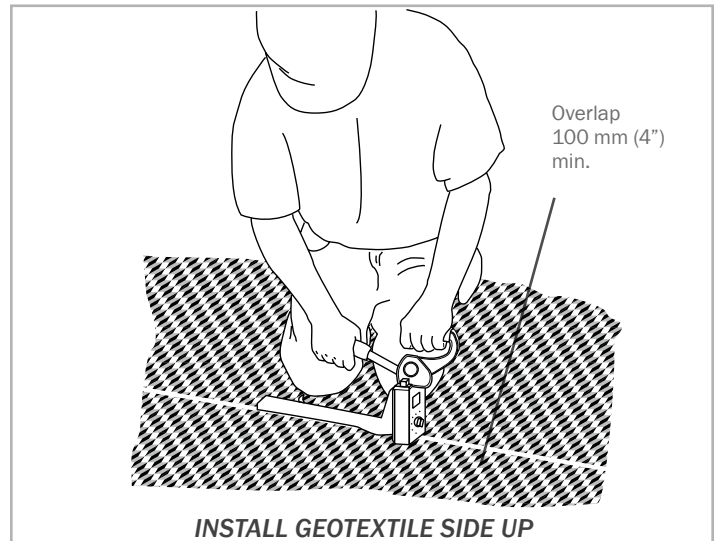

Figure 1.2 – Secure overlaps together with fasteners

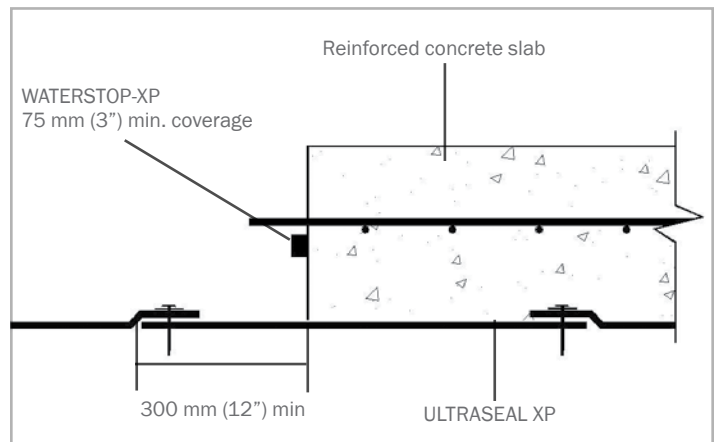

Figure 1.3 – Extend ULTRASEAL XP a minimum 300 mm (12") beyond slab edge. Install WATERSTOP-XP in joint

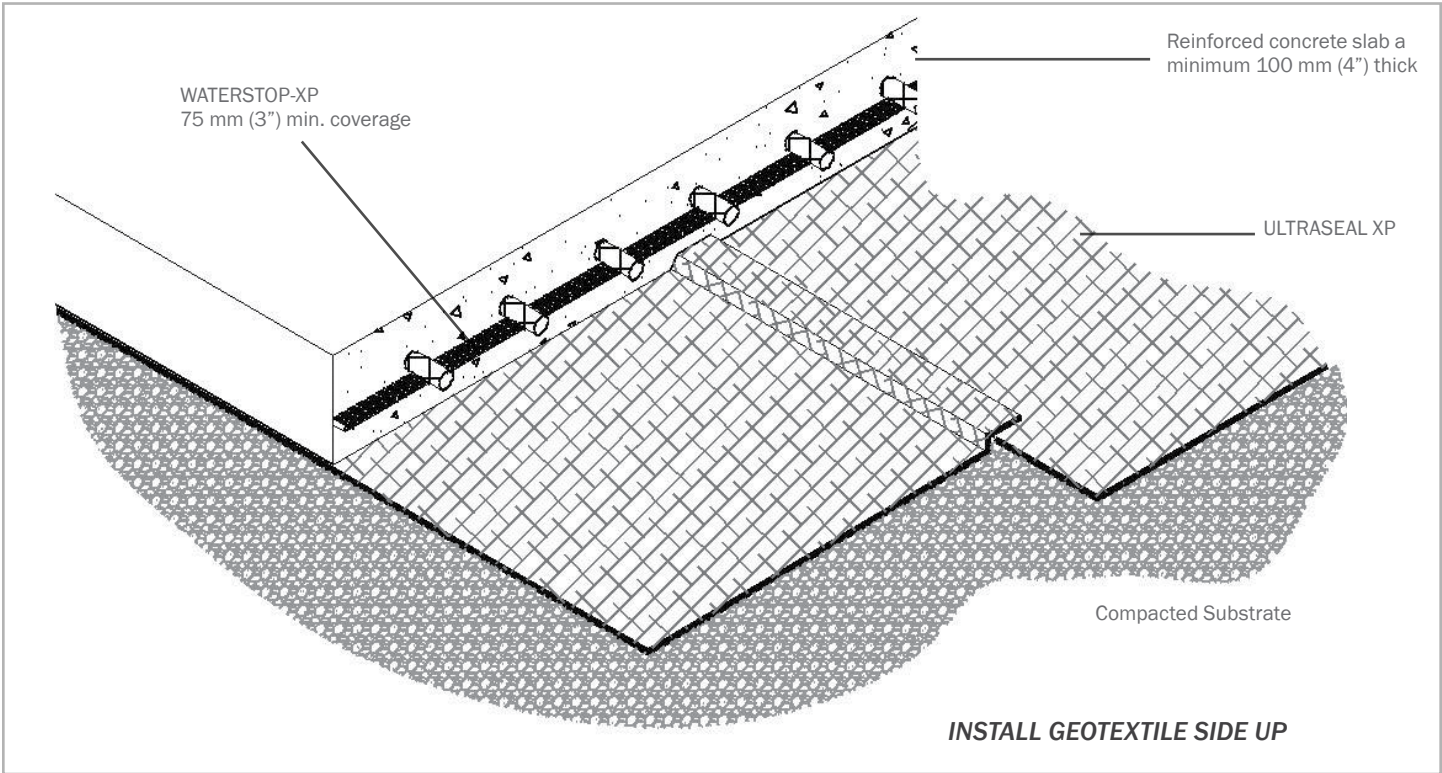

Figure 1.4 - ULTRASEAL XP installed directly over compacted earth/gravel substrate requires a minimum 100 mm (4") slab

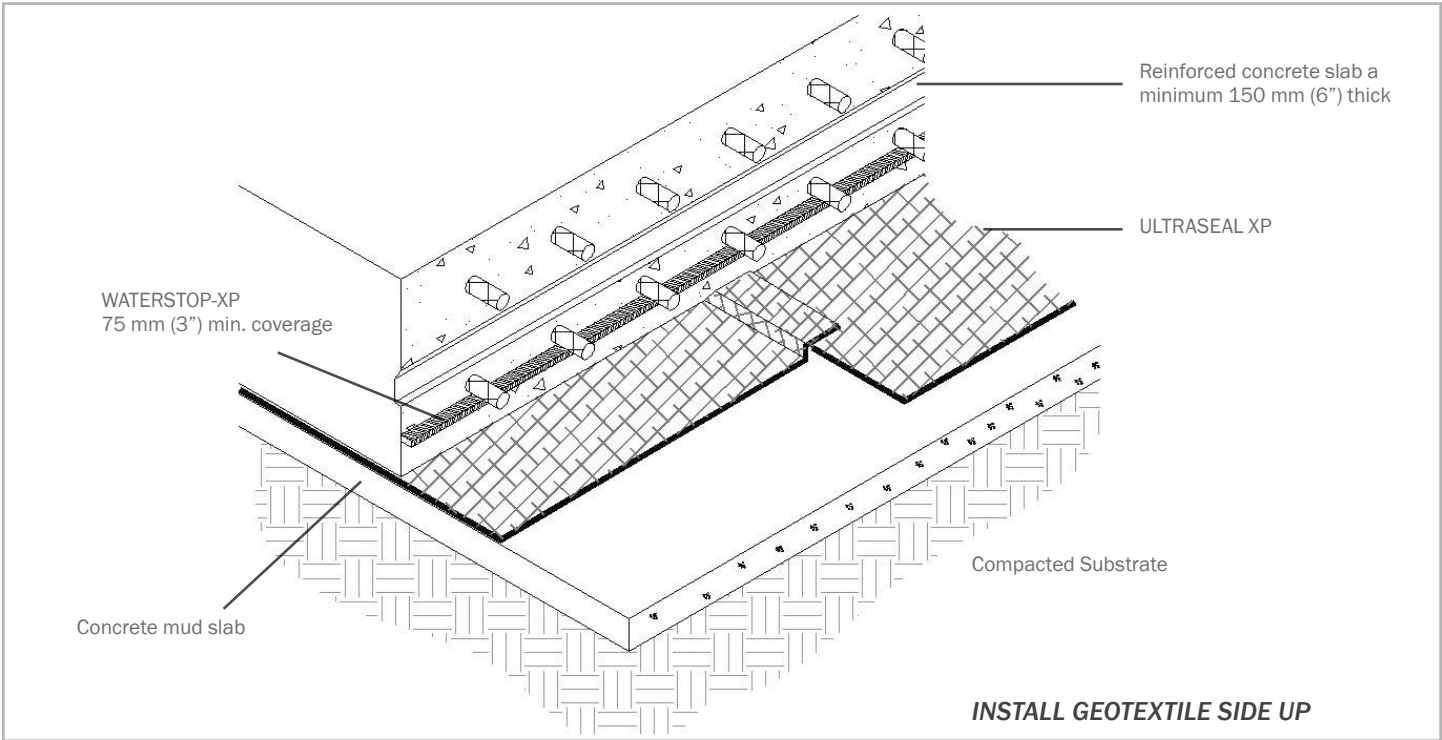

Figure 1.5 - ULTRASEAL XP installed over a mud slab requires a minimum 150 mm (6") thick reinforced slab

ULTRASEAL XP ACTIVE POLYMER WATERPROOFING SYSTEM

HYDROSTATIC CONDITIONS

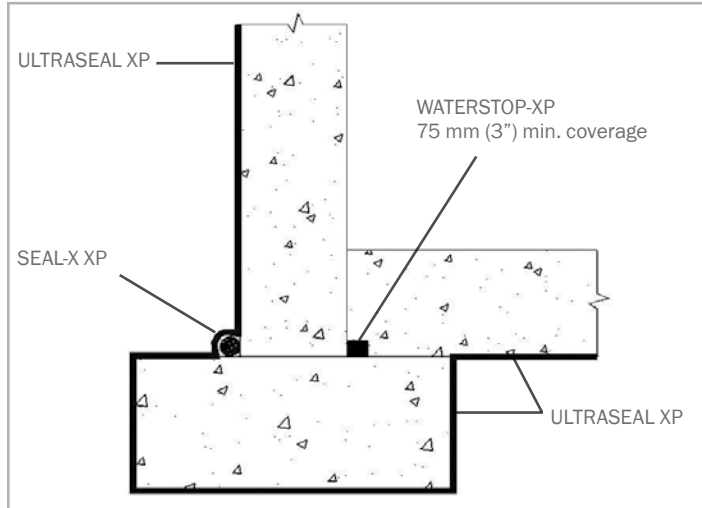

Figure 1.6 – Slab on footing detail (hydrostatic)

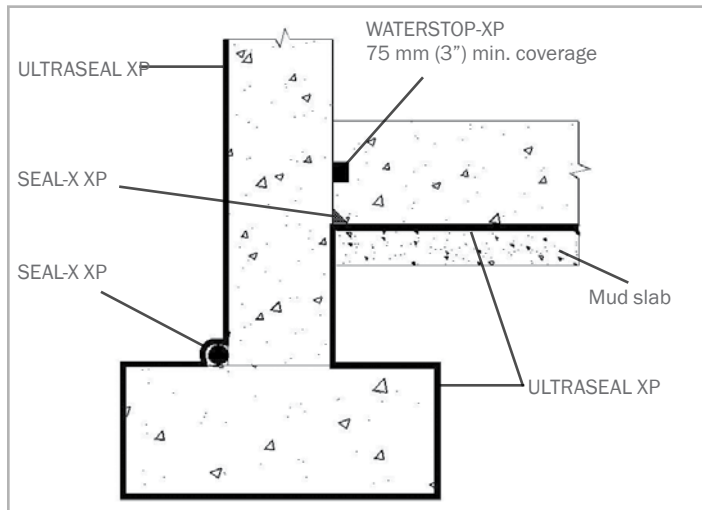

Figure 1.7 – Raised slab detail with mud slab (hydrostatic)

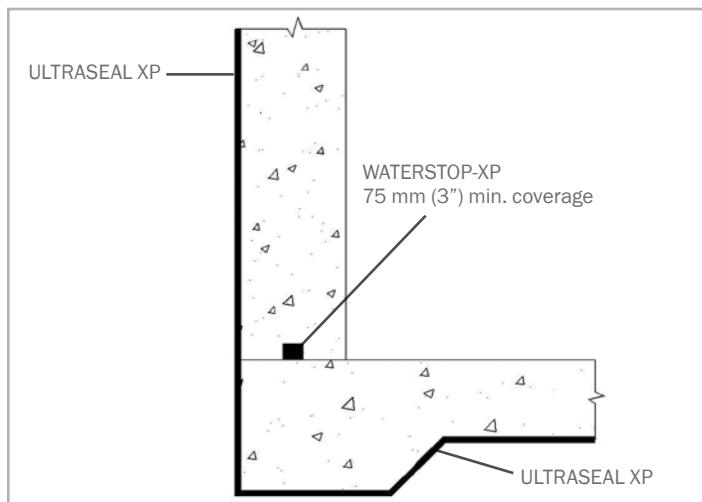

Figure 1.8 – Flush slab detail property line wall (hydrostatic)

NON-HYDROSTATIC CONDITIONS

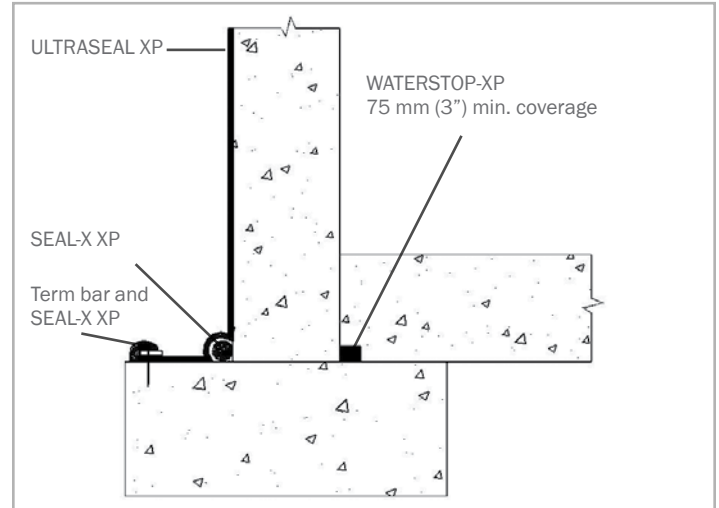

Figure 1.9 – Slab on footing detail (non-hydrostatic)

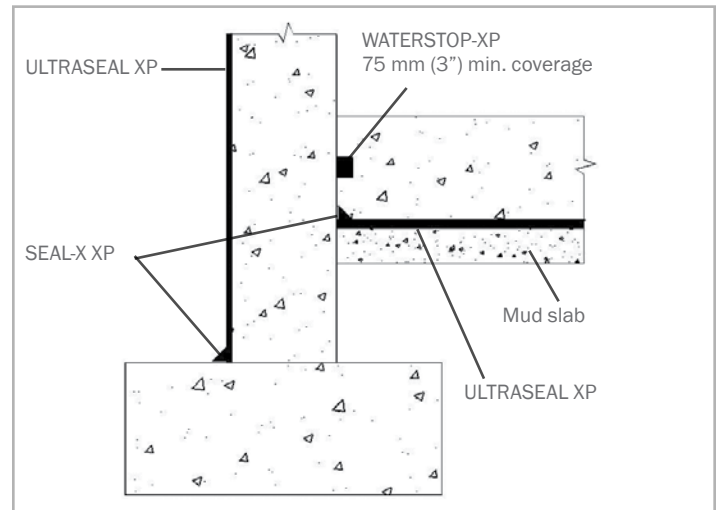

Figure 1.10 – Raised slab detail with mud slab (non-hydrostatic)

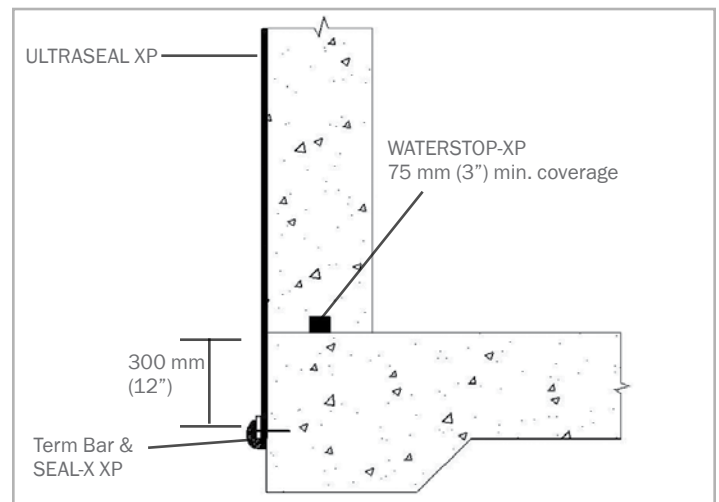

Figure 1.11 – Flush slab detail backfilled wall (non-hydrostatic)

1.3 PILE CAPS AND GRADE BEAMS

ULTRASEAL XP is typically not installed over pile caps but cut to fit tightly around pile caps. Then apply a minimum 19 mm (¾") thick fillet of SEAL-X XP at intersection of membrane and the piling (Figure 1.12) with SEAL-X XP under the membrane at the piling edge, SEAL-X XP should extend onto the membrane and piling a minimum of 50 mm (2") at 19 mm (¾") thickness. WATERSTOP-XP should be installed on top surface of pile cap around reinforcing steel (Figure 1.12).

Detail pile caps (Figure 1.13) the same as grade beams (Figure 1.14) with a non-hydrostatic condition. For hydrostatic conditions, ULTRASEAL XP should be installed under the entire grade beam (Figure 1.15). Line the grade beam formwork with ULTRASEAL XP prior to placement of reinforcing steel. Leave a minimum 300 mm (12") of ULTRASEAL XP at the top of the form to tie into below slab waterproofing.

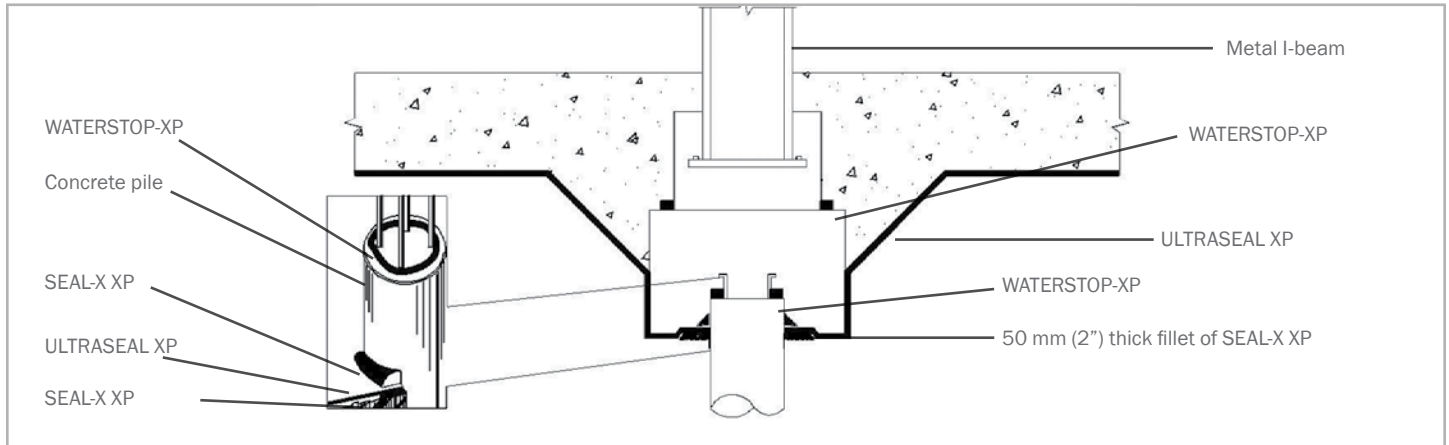

Figure 1.12 – Pile Cap Detail (Hydrostatic condition)

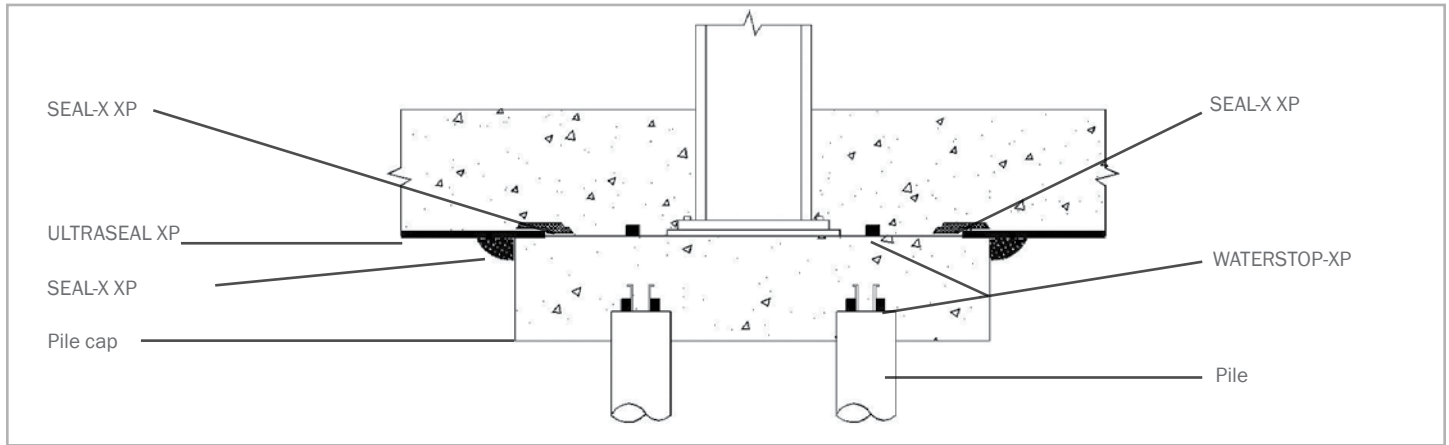

Figure 1.13 – Pile Cap Detail (Non-hydrostatic condition)

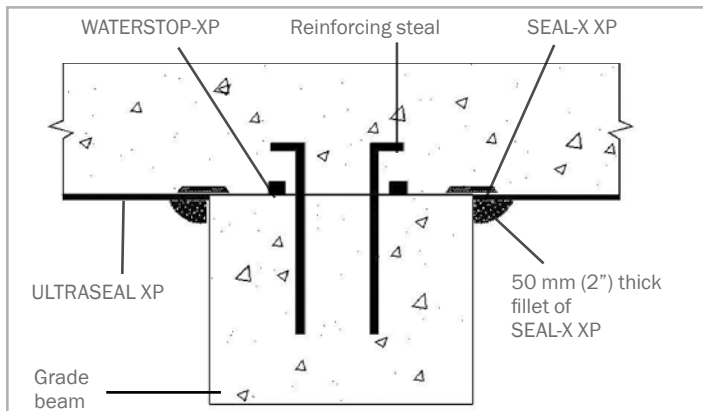

Figure 1.14 – Grade Beam (Non-hydrostatic condition)

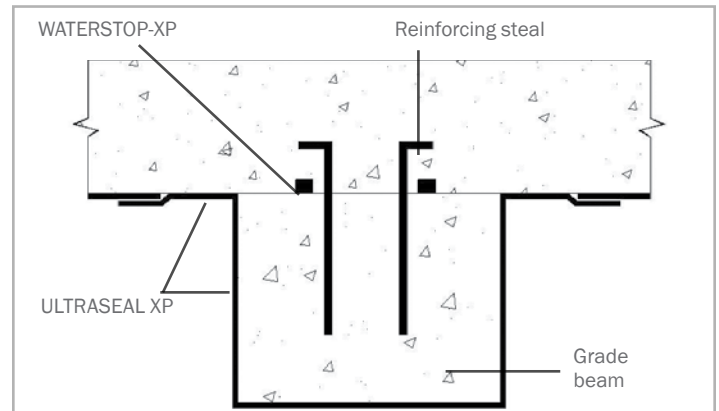

Figure 1.15 – Grade Beam (Hydrostatic condition)

ULTRASEAL XP
ACTIVE POLYMER WATERPROOFING SYSTEM

1.4 SLAB PENETRATIONS

Cut ULTRASEAL XP to closely fit around penetrations (Figure 1.16). Trowel a minimum 19 mm (¾”) thick fillet of SEAL-X XP around the penetration to completely fill any void area between ULTRASEAL XP and the penetration (Figure 1.17). The SEAL-X XP should extend up the penetration about 38 mm (1½”) and extend onto the membrane. In areas where multiple penetrations are close together, it may be

impractical to cut ULTRASEAL XP to fit around each penetration. Install SEAL-X XP a minimum 6 mm (¼”) thick around the penetrations covering the entire substrate area. With gravel substrate, install minimum 200 mm (8”) collar of ULTRASEAL XP around penetration prior to placing SEAL-X XP. Then apply a thick layer of SEAL-X XP around each penetration as detailed (Figure 1.18).

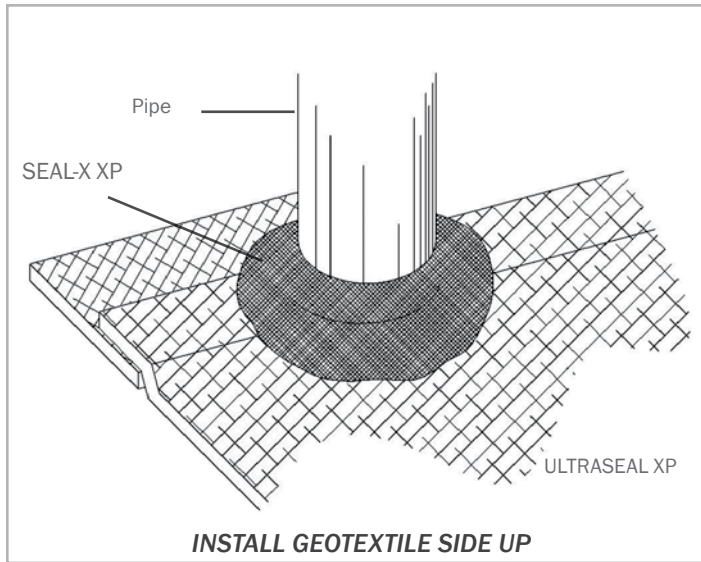

Figure 1.16 – SEAL-X XP troweled around penetrations

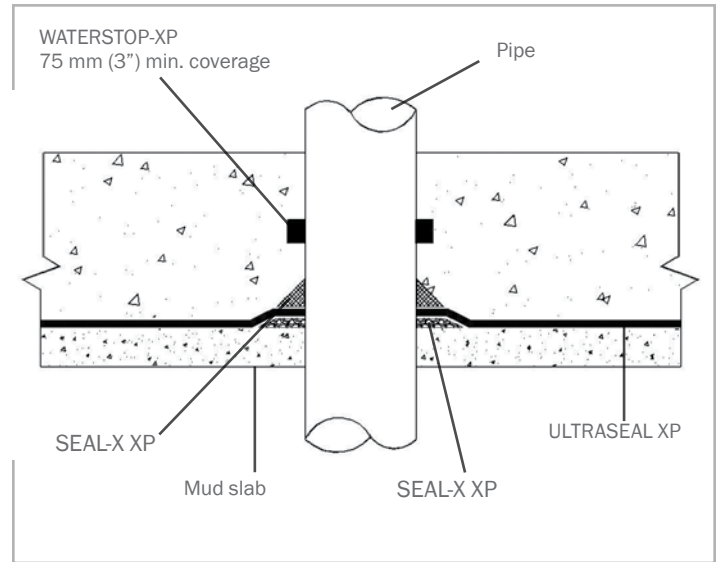

Figure 1.17 – Slab penetration cross section detail

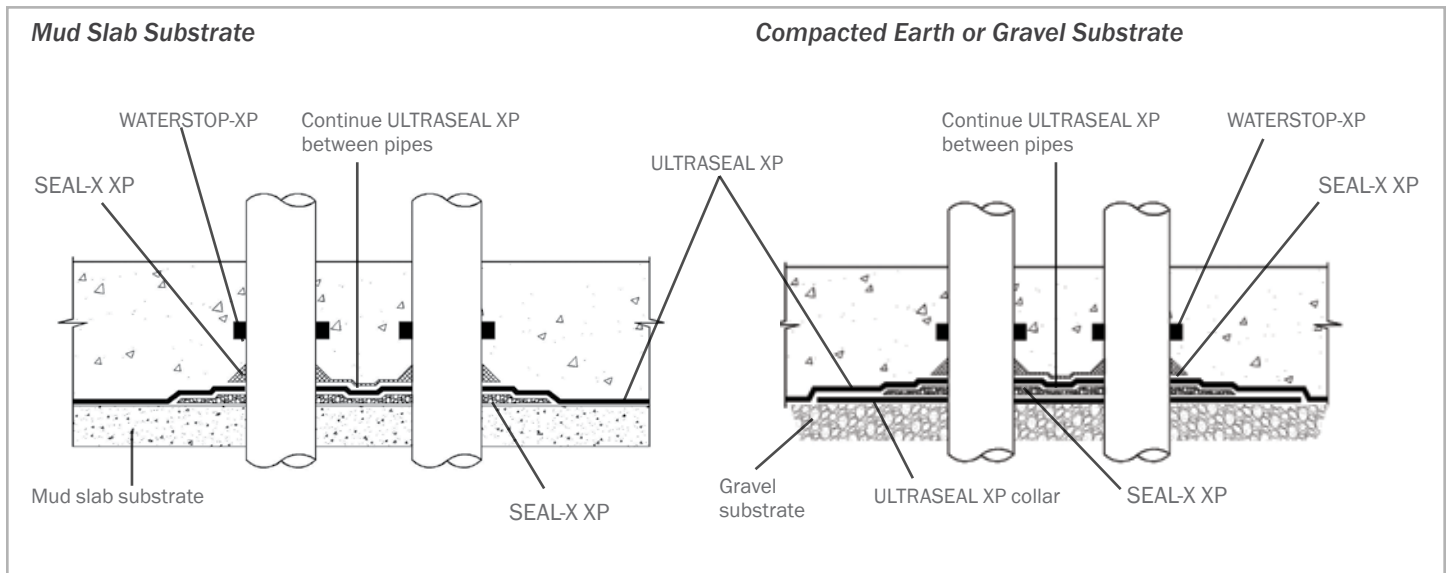

Figure 1.18 – Multiple pipe penetrations. Trowel SEAL-X XP around pipes and covering area between the pipes

1.5 ELEVATOR PITS

ULTRASEAL XP should be placed on vertical surfaces and on the substrate below the slab to form a continuous envelope around the elevator pit (Figure 1.19). If the vertical soil cut is smooth and stable, ULTRASEAL XP may be installed directly against the soil. Contain

unstable soils with a retaining wall. Install ULTRASEAL XP directly against the retaining wall. Due to various elevator piston plunger designs, consult CETCO for specific installation and detailing recommendations for piston plungers that penetrate the pit slab.

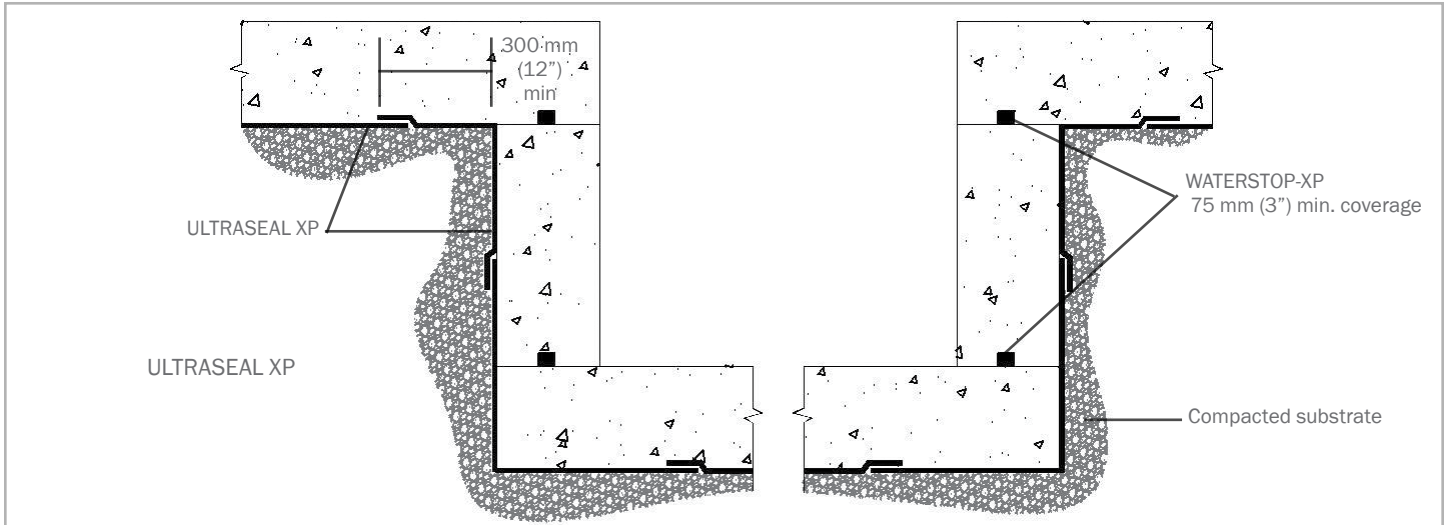

Figure 1.19 – ULTRASEAL XP under elevator pit slab and on excavation cut walls

1.6 EDGE OF SLAB, BACKFILLED WALLS

When the installation reaches the outer edge of the slab, continue ULTRASEAL XP up to the top edge of the forms inside surface (Figure 1.20) or extend the ULTRASEAL XP sheet out the top of the form a minimum of 300 mm (12") (Figure 1.21). At the slab corner, ULTRASEAL XP should remain in contact with the substrate and the inside surface of the concrete form. When the slab edge form is removed, any undamaged portion of ULTRASEAL XP extended outside the form should be positioned and secured to the top of the concrete footing.

Damaged material outside the form should be cut off and disposed of. Overlap the secured ULTRASEAL XP edge on top of the footing a minimum 150 mm (6") with the succeeding wall waterproofing. Install 38mm (1-1/2") fillet of SEAL-X XP at wall-to-footing corner prior to installing overlapping wall waterproofing.

WATERSTOP-XP should be installed in the perimeter wall/slab intersection joint as illustrated in Figure 1.22.

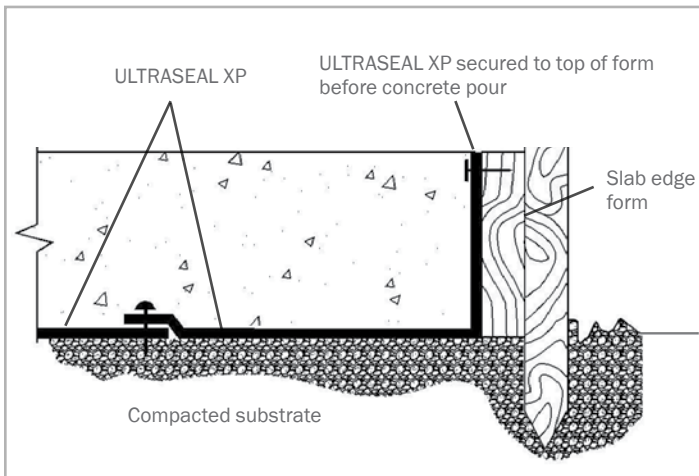

Figure 1.20 – ULTRASEAL XP turned up and secured at top of concrete form

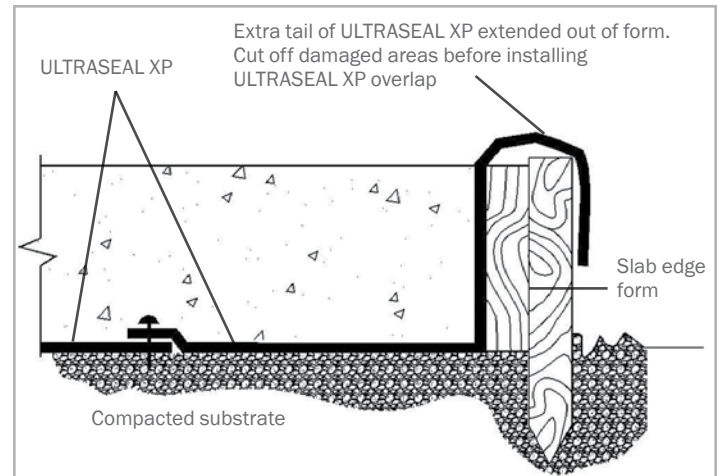

Figure 1.21 – Extra tail of ULTRASEAL XP extended out of form and later cut off after concrete pour

ULTRASEAL XP ACTIVE POLYMER WATERPROOFING SYSTEM

1.7 EDGE OF SLAB, PROPERTY LINE CONSTRUCTION

Where property line retaining walls, such as soldier pile and lagging, are used as the outside form, it is very important to extend the waterproofing a minimum 300 mm (12") above the top of the slab since there is no access to the outer edge of the slab after it is poured.

Slab to Wall Corner Transition: Install ULTRASEAL XP sheet horizontally oriented (Geotextile side facing installer) with a minimum 300 mm (12") of the sheet extending out onto the horizontal substrate. The top edge of the sheet must extend a minimum 300 mm (12") above the finished slab surface. Secure ULTRASEAL XP sheet to lagging wall with washer-head fastener maximum 600 mm (24") on center. Overlap edges of adjacent ULTRASEAL XP sheets a minimum 100 mm (4").

If the slab thickness is greater than 600 mm (24"), install a second full sheet or cut strip of ULTRASEAL XP, horizontally oriented, to meet the 300 mm (12") requirement above the slab. Overlap top edge of previous sheet and edges of adjacent sheets a minimum 100 mm (4").

Base Wall Course: Install first ULTRASEAL XP sheet course on the shoring wall horizontally oriented (Geotextile side facing installer) over the corner transition sheet, with the bottom edge extending down to the wall/slab transition corner as shown in Figure 1.22. Secure

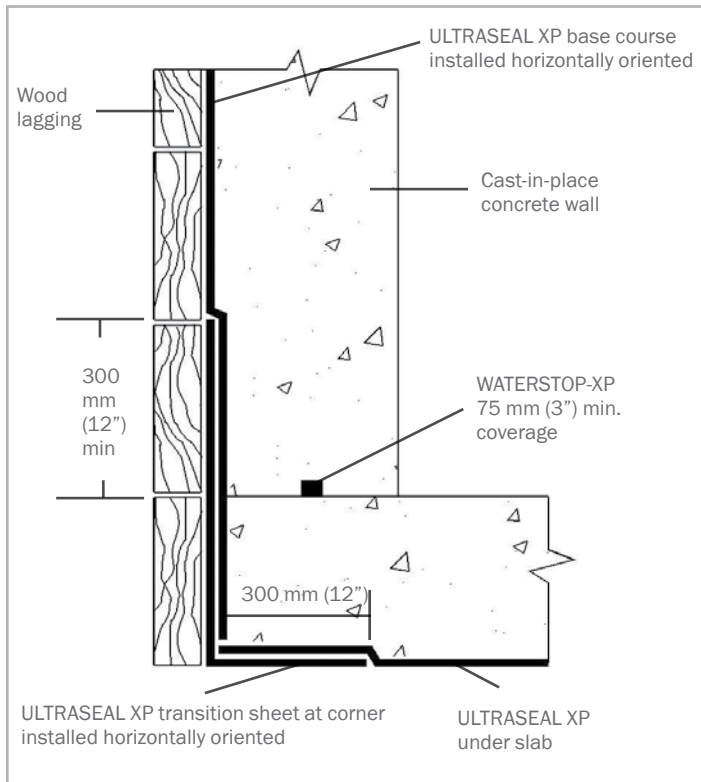

Figure 1.22 – SLAB-TO-WALL TRANSITION – ULTRASEAL XP corner transition sheet should extend past the height of the top of the finished slab level a minimum 300 mm (12") and extend under the slab 300 mm (12")

ULTRASEAL XP sheet to lagging wall with washer-head fasteners maximum 600 mm (24") on center. Overlap edges of adjacent ULTRASEAL XP sheets a minimum 100 mm (4").

Install underslab ULTRASEAL XP membrane extending to corner transition, overlapping the 300 mm (12") sheet tail of the corner transition sheet installed at the wall base. Secure corner edge with fasteners 300 mm (12") on center.

For metal sheet piling shoring walls, first install the ULTRASEAL XP corner transition sheet horizontally oriented with the bottom edge extending minimum 300 mm (12") out onto the substrate. Cut the bottom edge of the corner transition sheet at piling transition angles to allow the bottom edge to lay flat onto the substrate. Install 38 mm (1-1/2") continuous cant of SEAL-X XP along base of shoring wall. Then install underslab ULTRASEAL XP sheet cut to fit contours of metal sheet piling. Finally, install the base shoring wall ULTRASEAL XP sheet (horizontally oriented) overlapping the corner transition sheet.

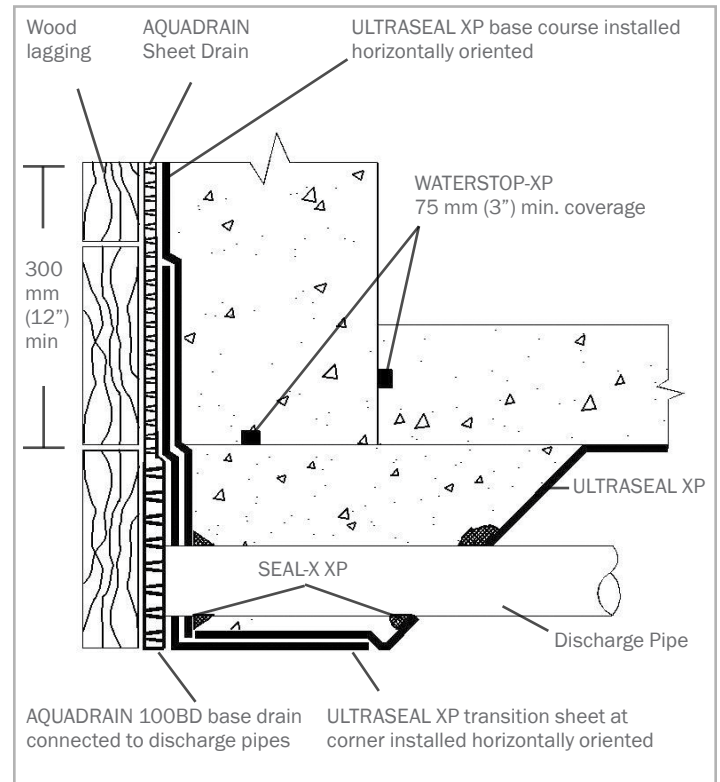

Figure 1.23 – AQUADRAIN 100BD DISCHARGE PIPE – Connect AQUADRAIN 100 BD to water discharge pipes using 100 BD accessory connections

SECTION 2 PROPERTY LINE CONSTRUCTION

The use of construction techniques described in this section allow the exterior building dimensions to coincide with the property line, thereby maximizing use of available land for building. ULTRASEAL XP has been proven to be one of the most effective means for waterproofing property line construction. Cast-in-place property line construction methods include soldier pile & lagging, metal sheet piling, earth formed shotcrete retention walls, and auger cast caisson walls.

For all property line construction methods, ULTRASEAL XP is installed to the shoring wall prior to concrete placement. Install ULTRASEAL XP with the Geotextile side inward, facing the installer, away from the shoring wall. Refer to each applicable construction method in Section 2 for specific substrate preparation and detailing installation guidelines.

AQUADRAIN sheet and 100BD base drain composite system should be connected to an operative water discharge system (sump pump or gravity to daylight discharge).

Protect waterproofing products from hydrating before material is contained with concrete or backfill. After any precipitation, standing water should be pumped off waterproofing as soon as possible.

Shoring Wall: Excavation work should provide shoring wall in good condition to receive waterproofing system. Wood lagging shoring should extend to the lowest level of the waterproofing installation with any voids or cavities exterior of the lagging filled with compacted soil or cementitious grout. Voids or cavities at tie-backs should be filled with grout or compacted soil prior to ULTRASEAL XP installation. Interior surface of lagging timbers should be monolithic and tight together with gaps less than 25 mm (1"). Gaps in excess of 25 mm (1") should be completely filled with cementitious grout or other solid material.

Cut rock excavations and concrete auger cast caisson retaining walls must be sufficiently planar. Typically a shotcrete or grout layer is required to provide acceptable surface to install ULTRASEAL XP.

Employ construction methods to stop water flowing through shoring wall prior to waterproofing installation. If only water seepage, install polyethylene sheeting over the seepage area prior to installing ULTRASEAL XP. Polyethylene sheeting should extend from seepage elevation to base of wall to protect entire waterproofing installation at that area.

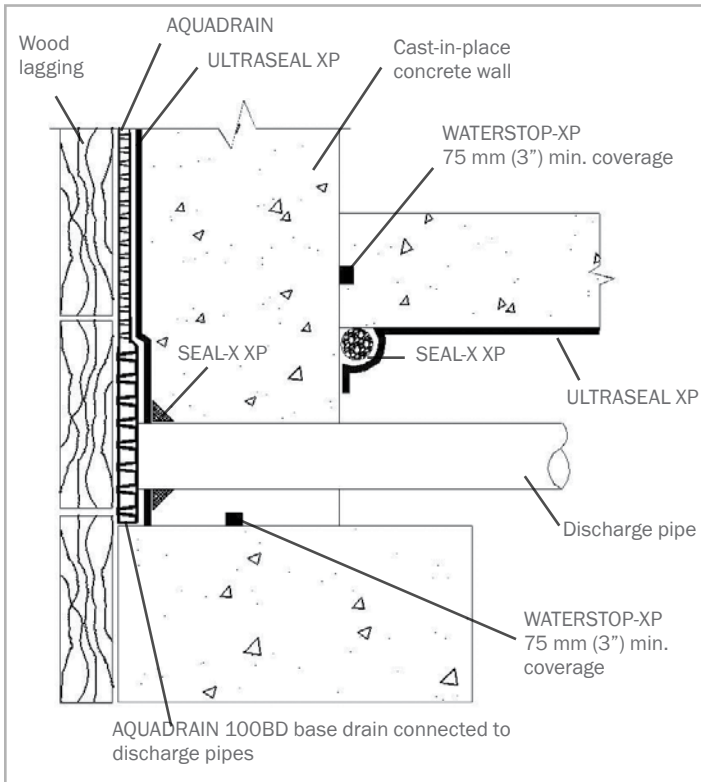

Figure 1.24 - RAISED SLAB CONDITION - Connect AQUADRAIN 100BD to water discharge pipes using 100BD accessory connectors

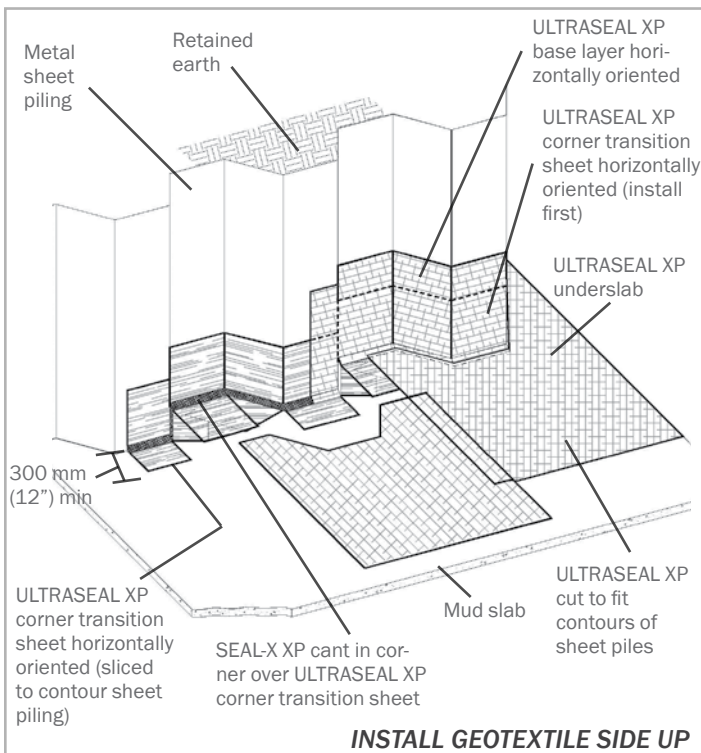

Figure 1.25 - Metal sheet piling to slab transition detail

ULTRASEAL XP ACTIVE POLYMER WATERPROOFING SYSTEM

2.1 PROPERTY LINE WALL INSTALLATION GUIDELINES

After the slab-to-wall corner transition sheet and bottom wall sheet course have been installed per Section 1.7 Page 11, ULTRASEAL XP sheets can be installed either vertically or horizontally oriented. Fasten the ULTRASEAL XP into position with washer-head fasteners maximum 600 mm (24") on center around the sheet edge. Install succeeding sheet overlapping the previous sheet edge 100 mm (4"). (Note: Shingle lap seams so that the bottom edge of the upper sheet is over the lower sheets top edge).

Continue installation up wall until grade elevation detail, or as specified, staggering all sheet ends of adjacent rolls a minimum 300 mm (12"). Do not allow sheet overlap joints to occur at same elevation as concrete cold joints. Plan by chalk lining the location of construction joints.

Penetrations: Install a cut collar of ULTRASEAL XP tightly around the penetration; extending a minimum 300 mm (12") radius. Apply SEAL-X XP over ULTRASEAL XP collar around penetration; extending SEAL-X XP a minimum 75 mm (3") radius at 6 mm (3/4") thickness. Then install main course of ULTRASEAL XP membrane tightly around the penetration. Finally, detail around penetration with 19 mm (3/4") thick cant of SEAL-X XP. With sleeved pipes, The concrete work should include filling the gap between the pipe and the sleeve with non-shrink cementitious grout, mechanical seal by others and install WATERSTOP-XP to outside of sleeve.

Tie-Back Covers: Select appropriate size TB-Boot to fit over tie-back plate and allow proper cast-in-place concrete coverage per project requirements. TB-Boot should fit over entire tie-back head without the tie-back plate or cables in direct contact with the TB-Boot. Prior to TB-Boot installation, fill voids in retention wall substrate and tie-back head assembly with spray foam (min 20 psi) or non-shrink grout. For non-hydrostatic conditions, install and secure AQUADRAIN drainage composite course per manufacturer's guidelines to soil retention wall prior to installing TB-Boot. For hydrostatic conditions, install TB-Boot prior to ULTRASEAL XP membrane. With soldier piles, strip piles with waterproofing membrane prior to TB-Boot placement.

Fill pre-formed shape of TB-Boot with 2-part urethane spray foam (min 20 PSI) and place over tie-back head before foam sets up. Secure TB-Boot to soil retention system using washer head fasteners along the outside edge of the flat base. Apply 6 mm (1/4") thick by minimum 75 mm (3") wide continuous ring of SEAL-X XP onto the flat base just outside of the 12 mm (1/2") raised collar. Install 4-ft by 4-ft piece of ULTRASEAL XP (with pre-cut hole in center to fit tight around the 12mm (1/2") raised collar) over the entire flat base with outside edges fastened to the retaining wall. Secure inside ULTRASEAL XP edge around raised collar with washer-head fasteners that pass through the SEAL-X XP ring; typical fastener spacing 150 mm (6"). Do not install fasteners or puncture TB-Boot inside of the 12 mm (1/2") raised collar. Apply counter flashing of SEAL-X XP along ULTRASEAL XP sheet edge around raised collar. Then install ULTRASEAL XP field sheet overlapping outer membrane edge minimum 100 mm (4").

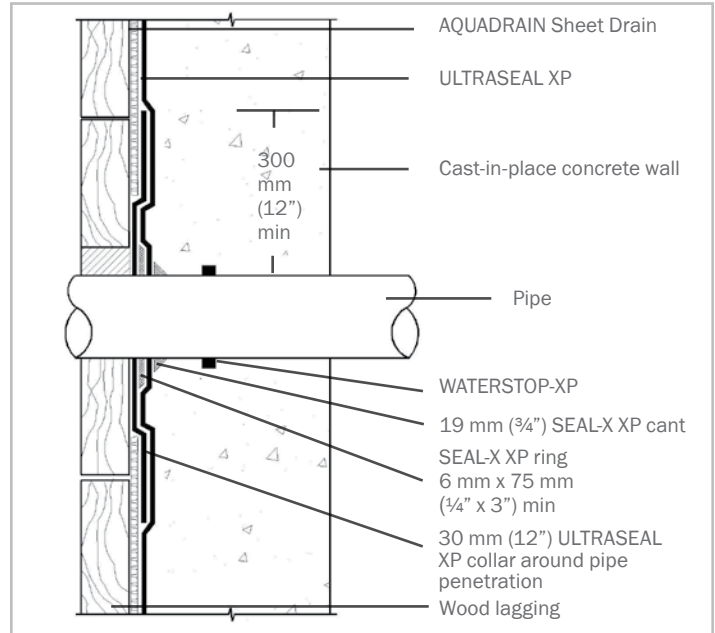

Figure 2.1 - WALL PENETRATION - Cut and secure ULTRASEAL XP tightly around penetrations and then apply SEAL-X XP 19 mm (3/4") ring around penetration and extend over membrane a minimum 75 mm (3") radius at minimum 6 mm (1/4") thickness. Then install main course of ULTRASEAL XP membrane tightly around penetration. Finally, detail around penetration with a 19mm (3/4") SEAL-X XP fillet

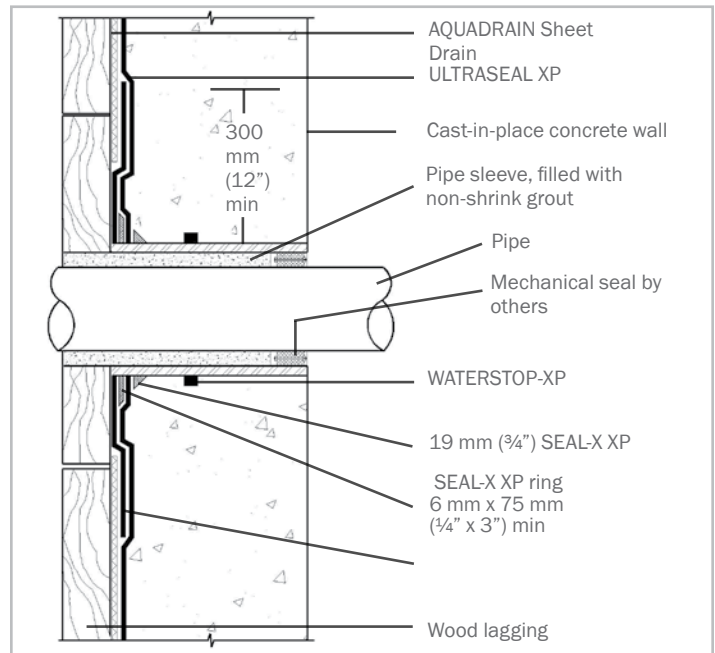

Figure 2.2 - SLEEVED WALL PENETRATION - Cut and secure ULTRASEAL XP tightly around penetrations and then apply SEAL-X XP 19 mm (3/4") ring around penetration and extend over membrane a min. 75 mm (3"). Then install main course of ULTRASEAL XP membrane tightly around penetration. Finally, detail around penetration with a 19mm (3/4") SEAL-X XP fillet

NON-HYDROSTATIC CONDITIONS

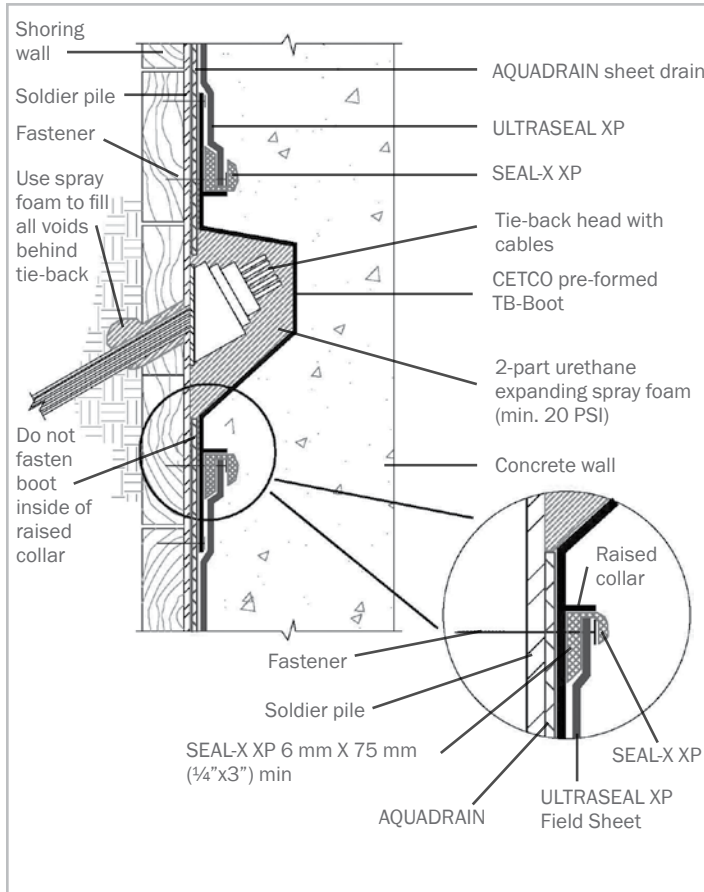

Figure 2.3: TIE-BACK DETAIL – Install TB-Boot centered over tie-back then install main course of ULTRASEAL XP with SEAL-X XP detailing. Do not fasten boot inside of raised collar around center formed area

Soldier Pile Stripping: Install a strip of ULTRASEAL XP over all soldier piles with raised lagging hanger bolts, form tie rods, or other irregular surface. ULTRASEAL XP strip should extend a minimum 150 mm (6") to both sides of the piling. Apply SEAL-X XP 6 mm x 50 mm (1/4" x 2") to ULTRASEAL XP strip surface along both edges of each soldier pile (Figure 2.6).

Cementitious Board: Prior to installing ULTRASEAL XP to finished grade, install 12 mm (1/2") thick cementitious wall board centered over steel soldier pile from finished grade elevation to specified depth that the top of steel soldier pile and wood lagging will be removed (Figure 2.10).

Grade Termination: Terminate ULTRASEAL XP membrane 300 mm (12") below finished grade elevation with washer-head fasteners maximum 300 mm (12") on center. Install ENVIROSHEET flashing to primed concrete substrate with bottom edge overlapping top edge of ULTRASEAL XP membrane minimum 100 mm (4"). Overlap all roll ends a minimum 4" (100 mm) to form a continuous flashing. Height

HYDROSTATIC CONDITIONS

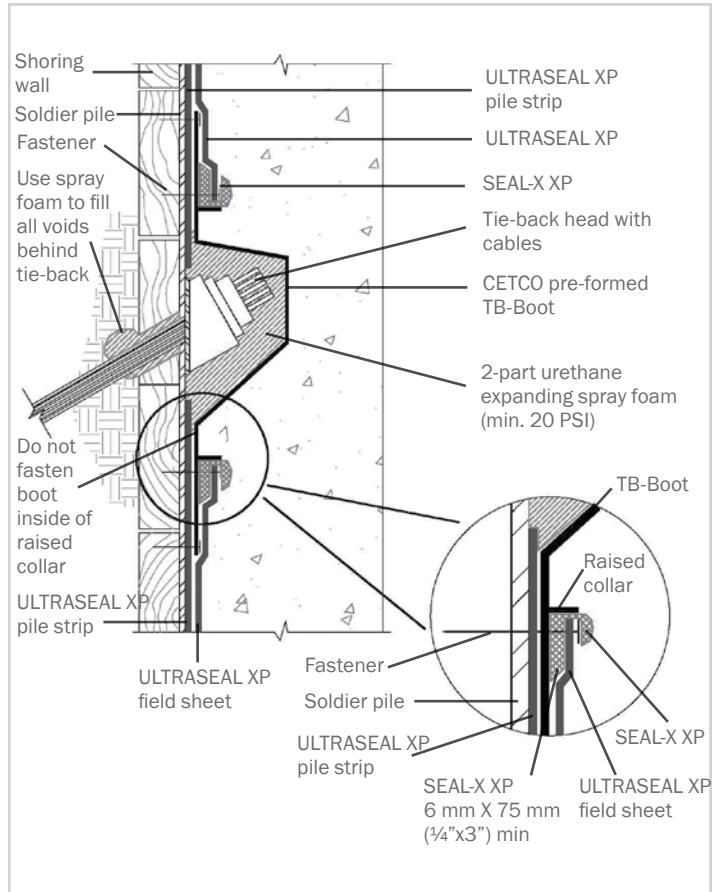

Figure 2.3a: TIE-BACK DETAIL – Install TB-Boot centered over tie-back then install ULTRASEAL XP with SEAL-X XP detailing. Do not fasten boot inside of raised collar around center formed area

of flashing shall be per project details and specifications. Install a rigid termination bar along top edge of ENVIROSHEET; fastened maximum 300 mm (12") on center. Complete grade termination detail with tooled bead of CETSEAL along the top edge, at all penetrations through the flashing, and all exposed overlap seams.

Where lagging timbers and the top end of steel soldier piles are removed, repair any waterproofing damaged by the excavation and removal of the retention wall system. Secure all excavated ULTRASEAL XP overlap seams with washer-head fasteners maximum 600 mm (24") on center and then apply Seamtape centered along overlap seams. Backfill shall be placed and compacted to minimum 85% Modified Proctor density promptly after waterproofing installation. Backfill should consist of compactable soil or angular aggregate 19 mm (3/4") or less free of debris, sharp objects, and stones larger than 19 mm (3/4"). See termination details, Figure 3.11 and 3.12, page 23.

ULTRASEAL XP

ACTIVE POLYMER WATERPROOFING SYSTEM

2.2 SOLDIER PILE & LAGGING RETAINING WALL

Verify the following substrate preparation work has been completed. Then install ULTRASEAL XP following the property line installation guidelines in Section 2.1 on page 13 and 14.

Preparation: Gaps between the wood lagging must be no wider than 25 mm (1"). If the gaps between lagging are in excess of 25 mm (1"), the gaps should be completely filled with cementitious grout, wood, extruded polystyrene (40 psi min.) or compacted soil (Figure 2.4). If water is flowing through the lagging, a polyethylene sheeting can be installed over the area before ULTRASEAL XP is installed.

In areas with large gaps (up to 63 mm (2-1/2")) between lagging, AQUADRAIN sheet drainage composite can be installed over the lagging to provide a uniform surface to mount ULTRASEAL XP (Figure 2.5). Securely fasten AQUADRAIN to the lagging surface with washerhead nails before installing ULTRASEAL XP. Gaps larger than 63 mm (2-1/2") between lagging should be completely filled with grout, wood, extruded polystyrene (40 psi min.) or compacted soil even if AQUADRAIN is installed prior to ULTRASEAL XP. Do not use plywood or other surface treatment over large lagging gaps that leaves the cavity void. Figures 2.7 through 2.9 on page 15 illustrate the installation of ULTRASEAL XP over the different wood lagging positions relative to the soldier piling.

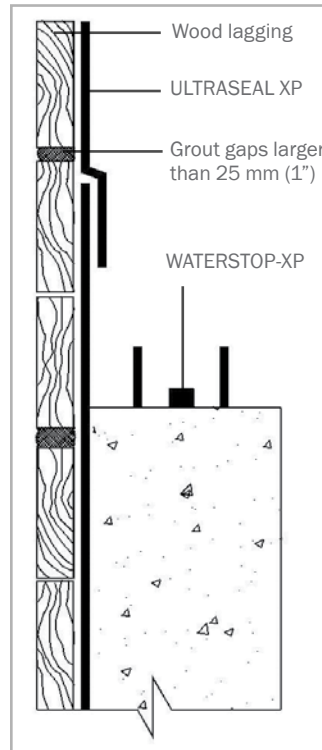

Figure 2.4 - ULTRASEAL XP installed directly to wood lagging with gaps filled. (Cast-in-place concrete wall)

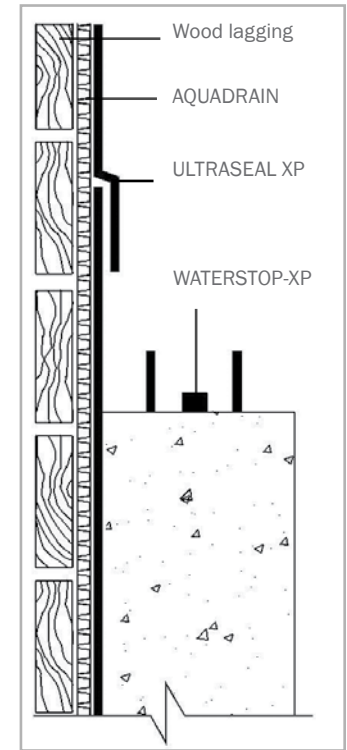

Figure 2.5 - AQUADRAIN used to cover gaps in lagging less than 63 mm (2.5"). (Cast-in-place concrete wall)

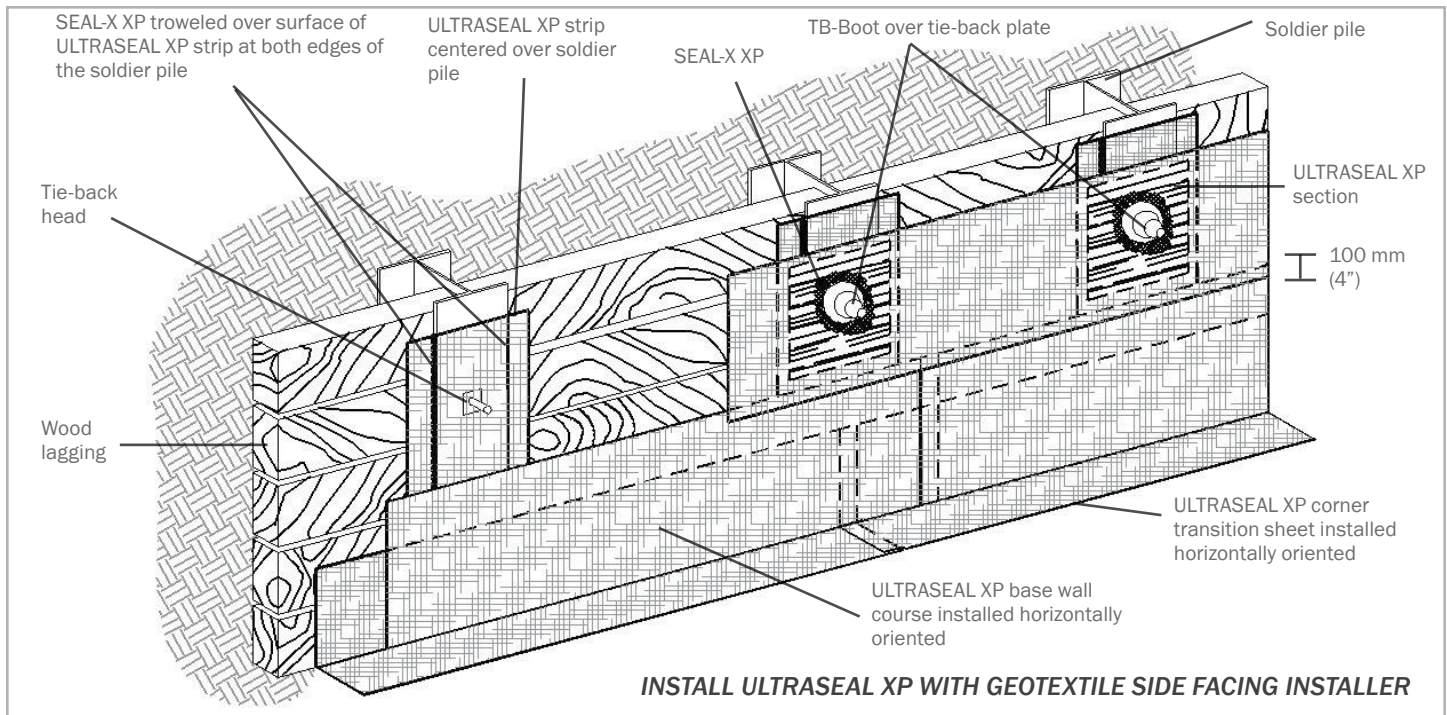

Figure 2.6 - Install ULTRASEAL XP onto soldier pile and wood lagging retaining wall prior to cast-in-place concrete wall

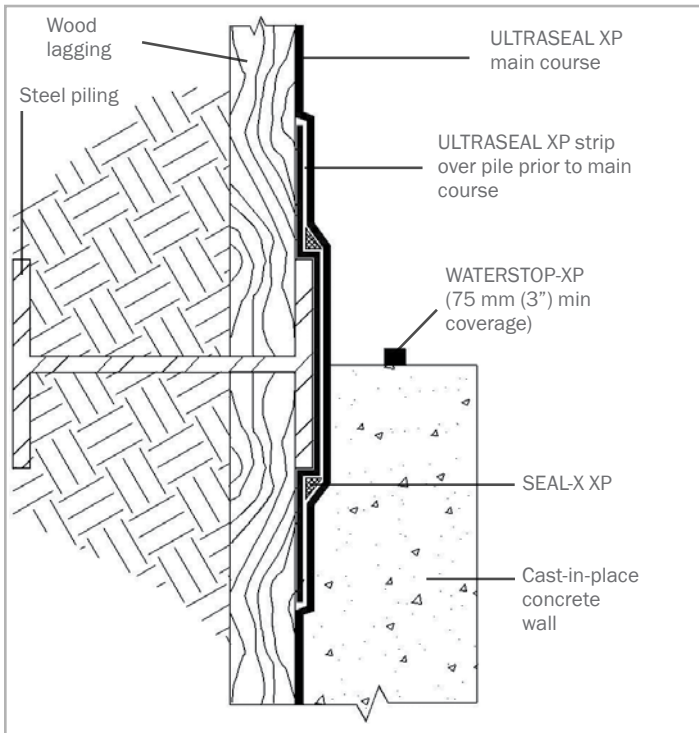

Figure 2.7 - Lagging secured to outside surface of front pile flange providing smooth surface (Plan View)

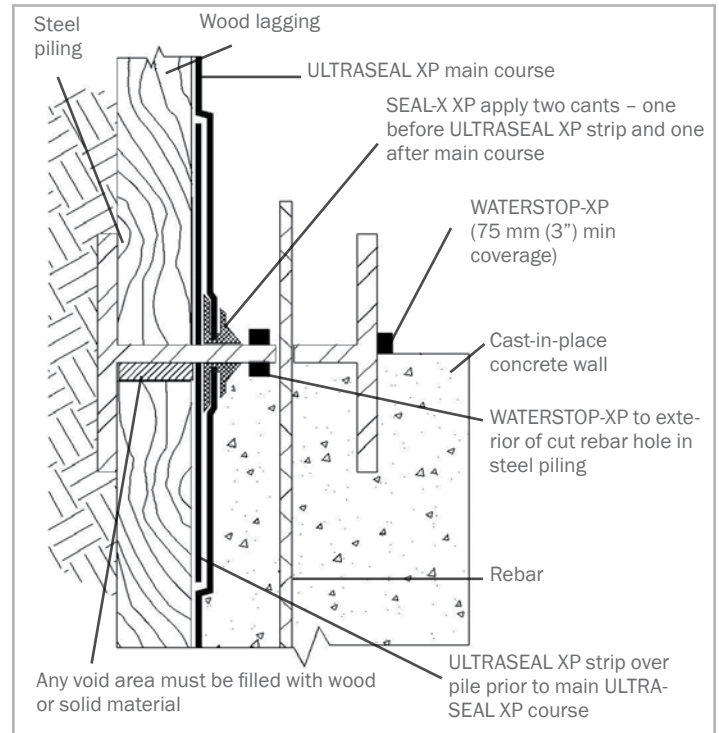

Figure 2.9 - Lagging secured to inside surface of back pile flange. Install SEAL-X XP and ULTRASEAL XP strip prior to main ULTRASEAL XP course and inward SEAL-X XP cant. (Plan View)

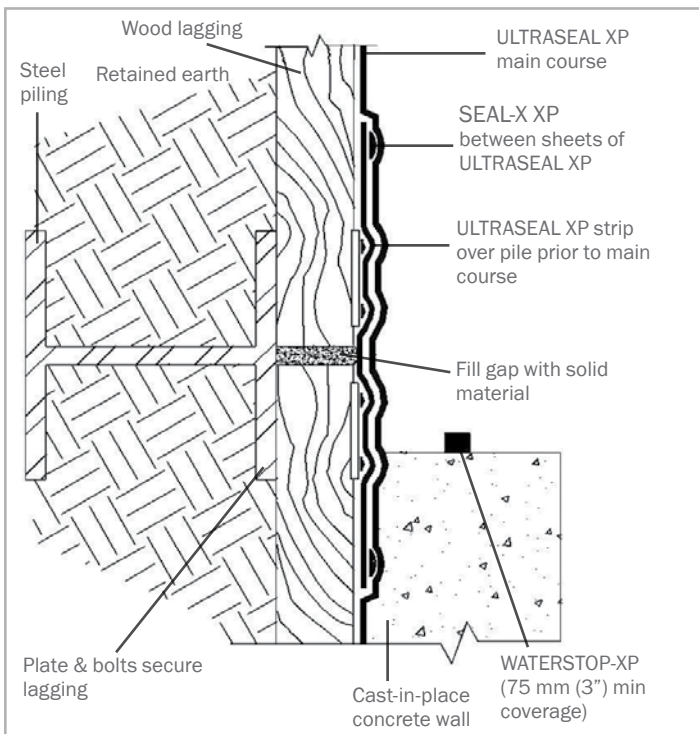

Figure 2.8 - Lagging secured to inside surface of front pile flange. Install ULTRASEAL XP strip to cover mounting plates and bolts prior to main course (Plan View)

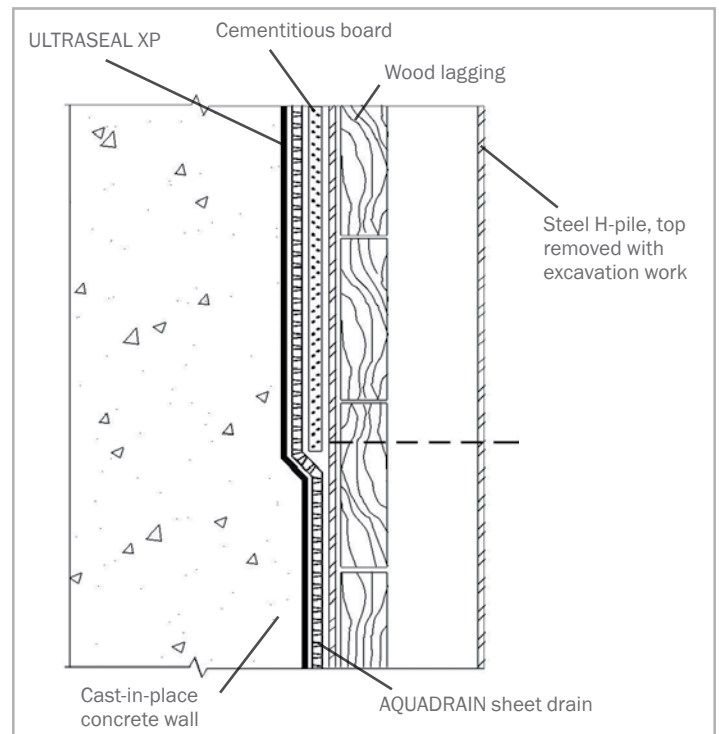

Figure 2.10 - WALL EXCAVATION AT GRADE - Cementitious board protects waterproofing during excavation and removal of steel pile top and wood lagging

ULTRASEAL XP ACTIVE POLYMER WATERPROOFING SYSTEM

2.3 METAL SHEET PILING RETAINING WALL

Verify the following substrate preparation work has been completed. Then install ULTRASEAL XP following the property line installation guidelines in Section 2.1 on page 13 and 14. Special knurled powder-actuated fasteners are recommended to secure ULTRASEAL XP to the metal sheet piling.

Preparation: Trowel a 12 mm (½”) thick layer of SEAL-X XP along all sheet piling knuckles. Fill voids or cavities at tie-back plates with cementitious grout or compacted soils. If excessive water is penetrating the sheet piling knuckles, BentogROUT can be injected to the outside of the knuckle to stop water flow (Figure 2.11). Consult CETCO for BentogROUT applications and installation guidelines.

Alternate Plywood Method

Alternatively, 12 mm (½”) plywood may be fastened to the sheet piling to create a flat surface upon which ULTRASEAL XP is fastened. All void spaces between the plywood and sheet piling must be filled with compacted earth or concrete. Apply ULTRASEAL XP to plywood following “Property Line Construction” Guidelines in Section 2, Page 12.

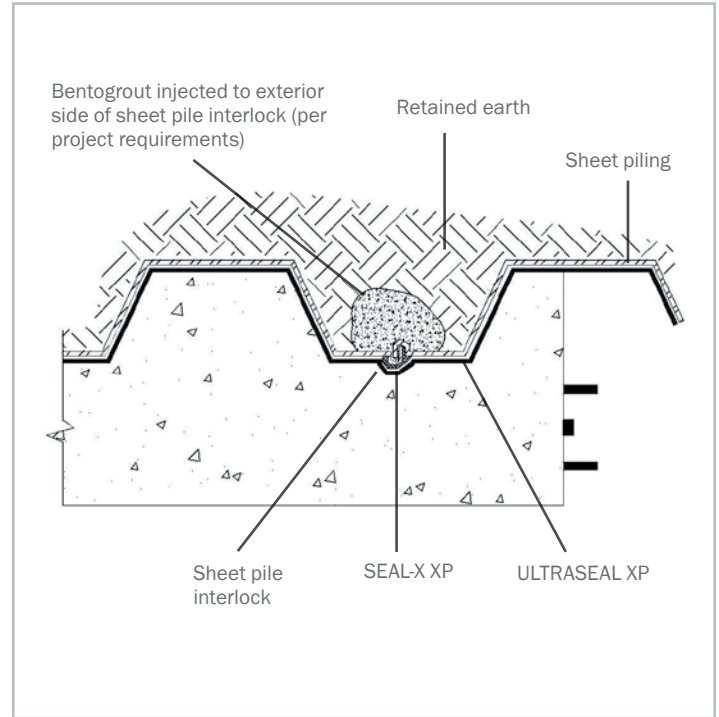

Figure 2.11 – Sheet pile interlock detail

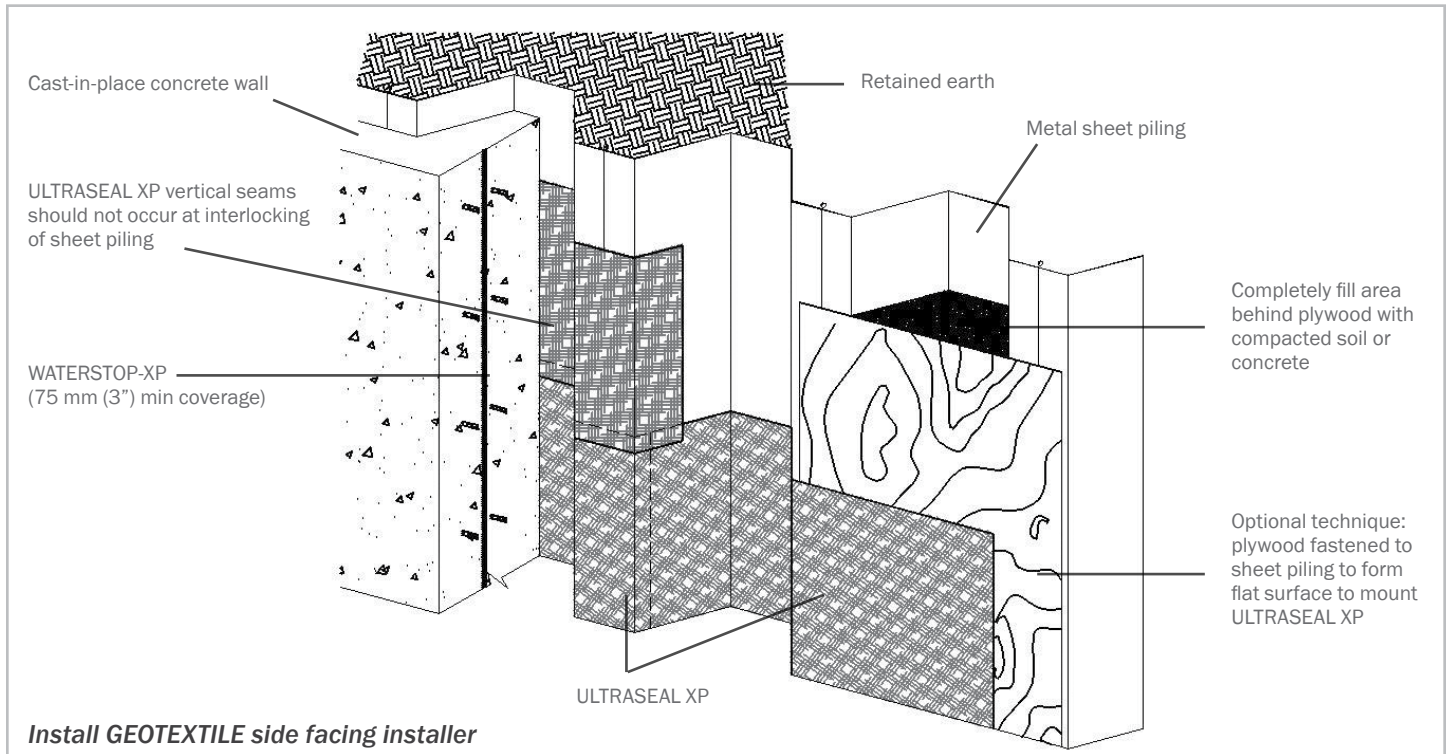

Figure 2.12 – Install ULTRASEAL XP onto metal sheet piling retaining wall with powder-actuated fasteners

2.4 EARTH FORMED SHOTCRETE RETAINING WALL

Verify the following substrate preparation work has been completed. Then install ULTRASEAL XP following the property line installation guidelines in Section 2.1 on page 13 and 14.

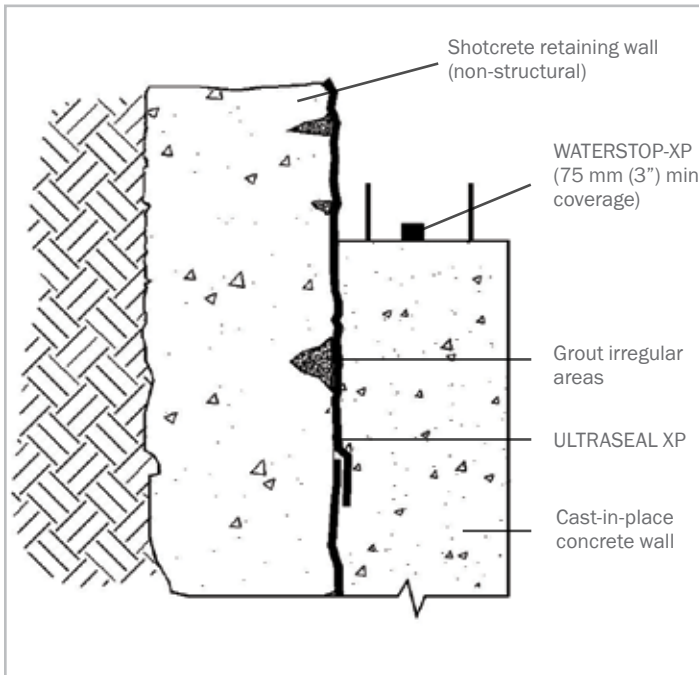

Figure 2.13 – Grout void area and remove protrusions to provide smooth surface for ULTRASEAL XP.

Preparation: The surface of the earth formed shotcrete retaining wall must be sufficiently planar to provide an adequately smooth surface to apply ULTRASEAL XP. ULTRASEAL XP can be applied over large, relatively shallow indentations. The surface should not contain voids or sharp protrusions in excess of 25 mm (1”). Fill all voids with cementitious grout and remove protrusions prior to installing ULTRASEAL XP (Figure 2.15).

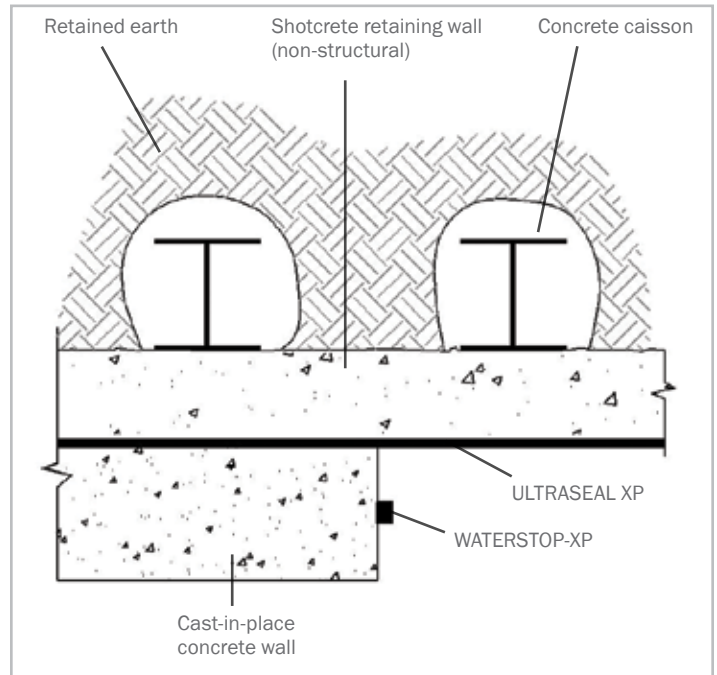

Figure 2.14 – Earth formed concrete retention wall with concrete caisson supports. (Plan View)

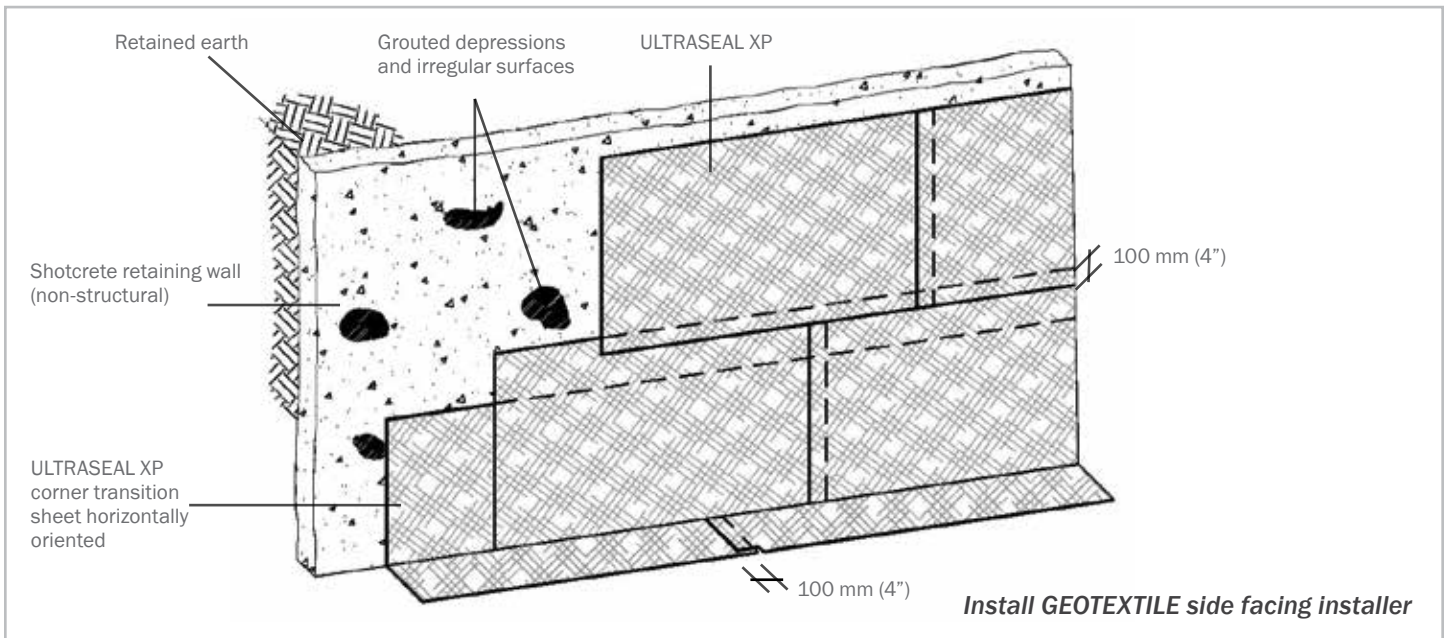

Figure 2.15 – ULTRASEAL XP installation over an earth formed shotcrete retention wall prior to cast-in-place concrete wall

ULTRASEAL XP

ACTIVE POLYMER WATERPROOFING SYSTEM

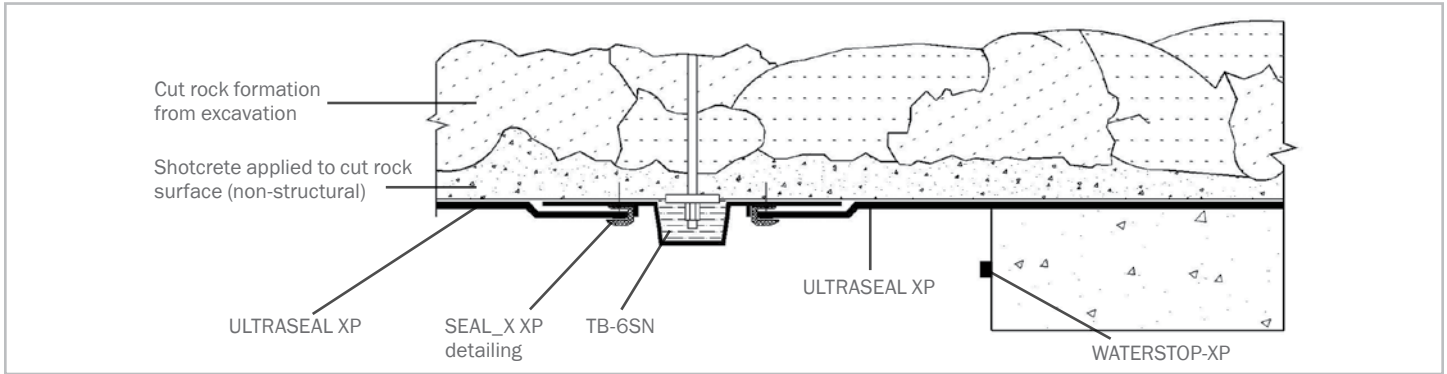

Figure 2.16 – Cut Rock excavation with shotcrete applied to provide a smooth surface for waterproofing installation.

2.5 AUGER CAST CAISSON WALLS

Verify the following substrate preparation work has been completed. Then install ULTRASEAL XP following the property line installation guidelines in Section 2.1 on page 13 and 14.

Preparation: The surface of auger cast caisson and cut rock excavation walls must be sufficiently planar to provide an adequately smooth surface to apply ULTRASEAL XP. ULTRASEAL XP can be applied over large, relatively shallow indentations where it can conform tight against the surface. The surface should not contain voids or sharp protrusions in excess of 25 mm (1"). Fill all large recesses between caissons with cementitious grout prior to installing ULTRASEAL XP (Figure 2.17). Cut rock excavations typically require shotcrete or grout work to provide acceptable surface to install ULTRASEAL XP (Figure 2.16).

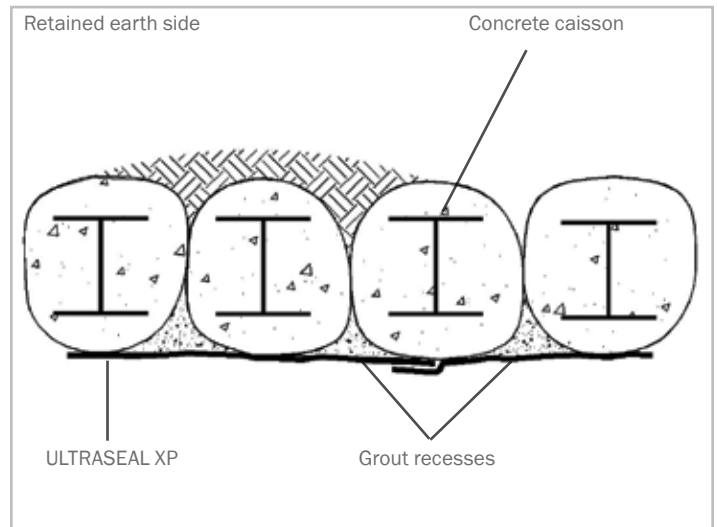

Figure 2.17 – Fill in recesses between cast caissons with grout to provide smooth surface (Plan View)

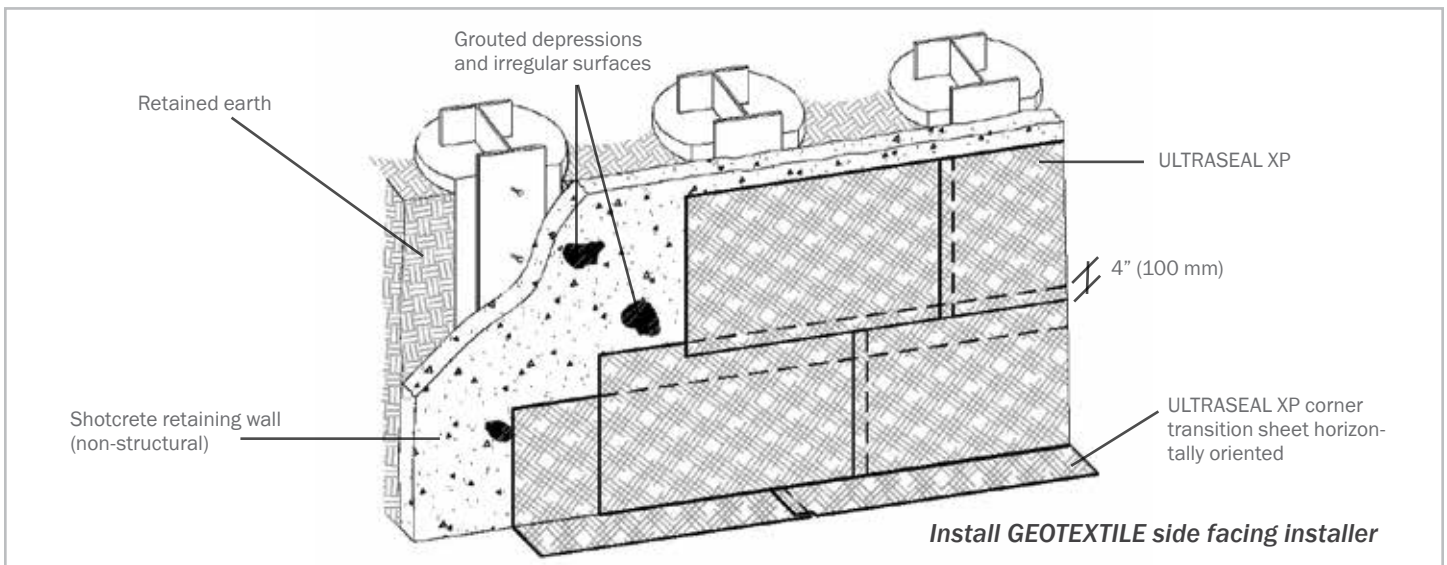

Figure 2.18 – ULTRASEAL XP installation over an auger cast concrete retention wall prior to cast-in-place concrete wall

SECTION 3 BACKFILLED WALLS

Install ULTRASEAL XP with the *geotextile side against the concrete wall (white geomembrane side facing installer)* on cast-in-place concrete foundation walls prior to backfilling. ULTRASEAL XP may be applied as soon as the forms are removed. It is not necessary to wait for the concrete to completely cure. Use ULTRASEAL XP with concrete cast with conventional forms that produce a smooth surface.

3.1 SURFACE PREPARATION

Footings should be swept clean of silt, rocks and debris to provide ULTRASEAL XP with direct contact to the concrete in the application area. The wall surface must be properly prepared before ULTRASEAL XP is installed. Areas of surface honeycombing or voids should be filled with cementitious grout or SEAL-X XP. Protrusions of over 6 mm (¼") should be knocked off smooth with the concrete surface. Concrete work should include completely filling taper-tie holes with non-shrink cementitious grout and a piece of WATERSTOP-XP centered in the wall. Apply SEAL-X XP over exterior grouted surface of all form tie holes (Figure 3.1).

3.2 INSTALLATION

Before installing the first course of ULTRASEAL XP, install a continuous 38mm (1-½") fillet of SEAL-X XP at the wall/footing inside corner (Figure 3.2).

Beginning at the bottom of the wall, install ULTRASEAL XP horizontally oriented with the bottom edge over the SEAL-X XP fillet and extending out a minimum 150 mm (6"). At corners cut the bottom edge of ULTRASEAL XP so that it can be extended onto the footing. Secure ULTRASEAL XP into position with washer-head fasteners a maximum 600 mm (24") on center. Then cut and install a section over the uncovered footing corner area. Apply SEAL-X XP at the corner section to the overlaps. (Figure 3.2).

Install adjacent ULTRASEAL XP rolls of the bottom course horizontally oriented. Each roll should overlap the preceding roll a minimum 50 mm (2") and should extend onto the footing a minimum 150 mm (6"). At vertical inside corners apply a continuous 19 mm (¾") fillet of SEAL-X XP directly in the corner prior to installing membrane (Figure 3.3). Stagger all vertical overlap joints minimum 300 mm (12") (Figure 3.4). When hydrostatic conditions exist, the vertical wall ULTRASEAL XP should cover the entire footing and overlap the underslab waterproofing a minimum 150 mm (6") (Figure 3.6). Succeeding membrane courses can be installed either vertically or horizontally oriented. Tape all membrane overlap seams with CETCO Seamtape (Figure 3.5).

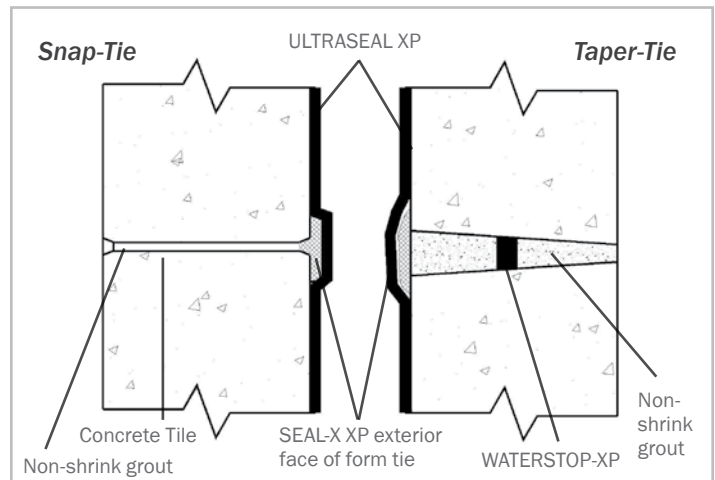

Figure 3.1 – Concrete form tie details

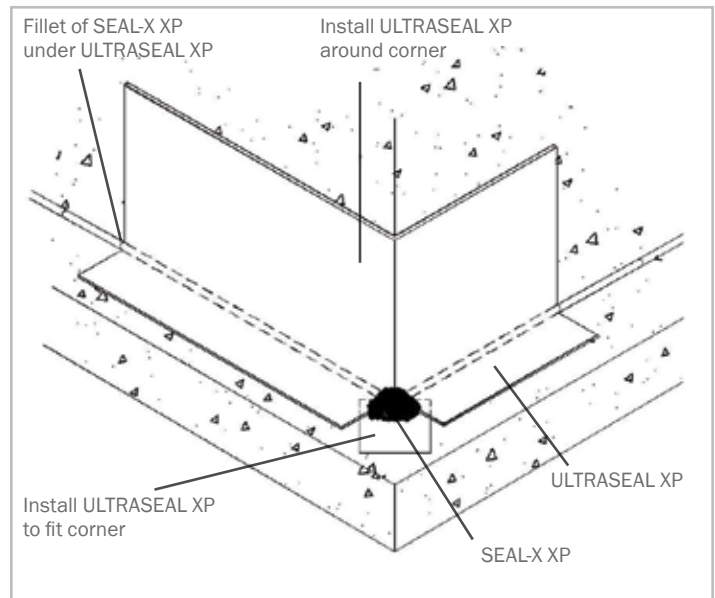

Figure 3.2 – Start ULTRASEAL XP at the corner horizontally. Place cut section at corner and apply SEAL-X XP at overlaps

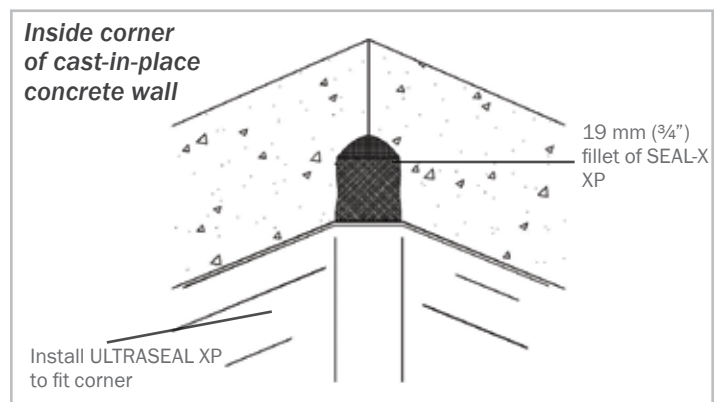

Figure 3.3 – Apply fillet of SEAL-X XP to inside corner

ULTRASEAL XP

ACTIVE POLYMER WATERPROOFING SYSTEM

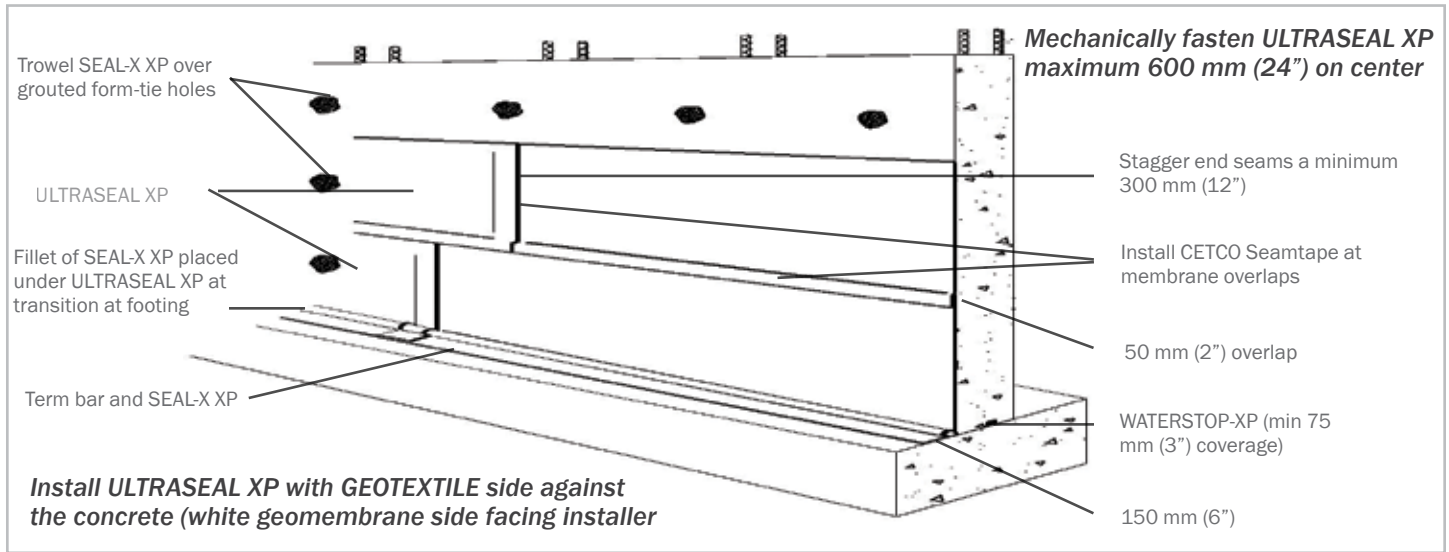

Figure 3.4 – ULTRASEAL XP installed on cast-in-place backfilled wall, overlap edges 50 mm (2”) and install Seamtape

Backfill: The excavated area should be backfilled and compacted promptly after ULTRASEAL XP is installed. Use placed backfill as a platform in applying succeeding ULTRASEAL XP courses. The backfill should be compacted to a minimum of 85% Modified Proctor density. Backfill should consist of compactible soils or angular aggregate (19 mm (¾”) or less) free of debris, sharp objects and stone larger than 19 mm (¾”). When backfill cannot be placed immediately, protect membrane from precipitation and debris by sealing edges to concrete substrate with CETCO Seamtape or tooled bed of CETSEAL. This temporary termination can be left in place covered by subsequent membrane overlap.

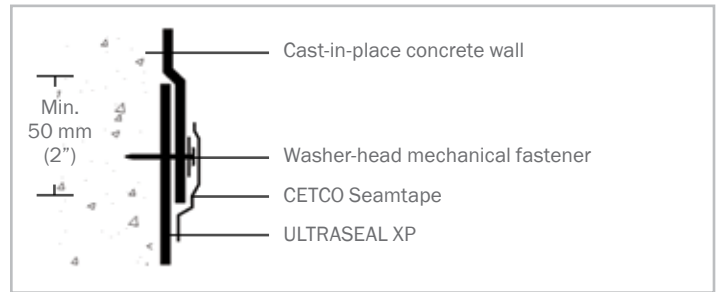

Figure 3.5 – Minimum ULTRASEAL XP overlap detail

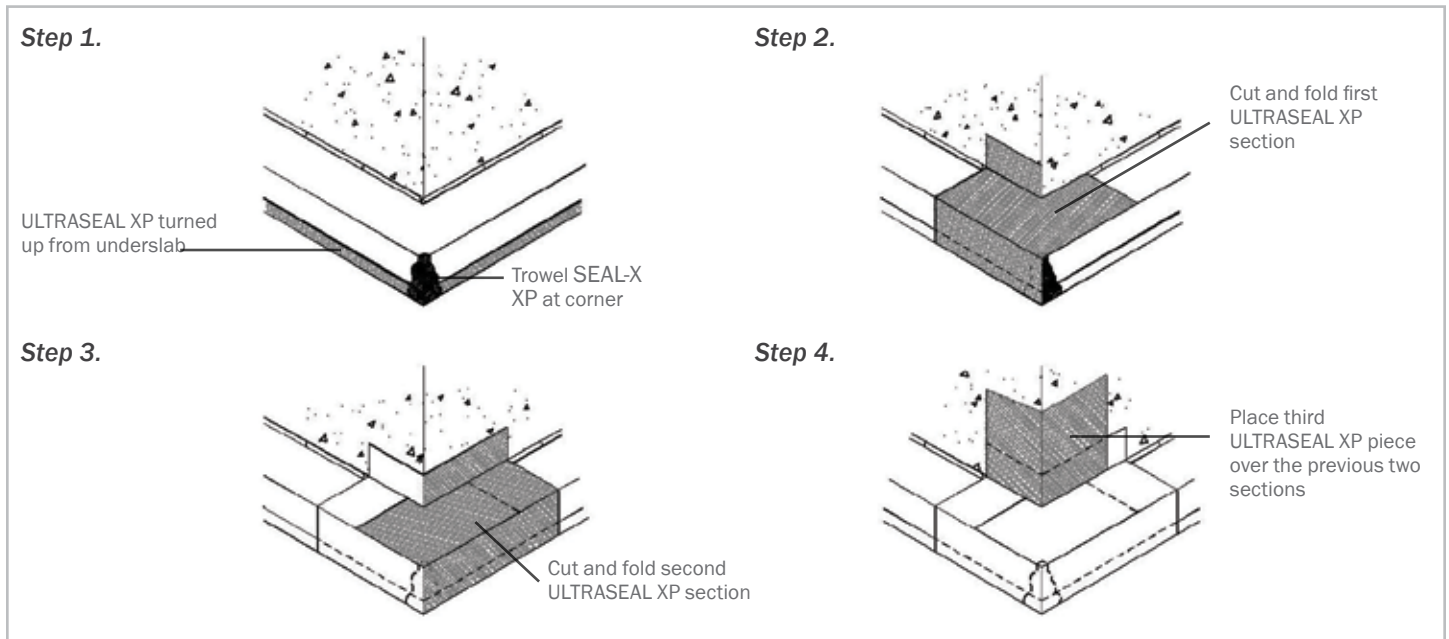

Figure 3.6 – Step by step detail of outside wall base corner installation (hydrostatic condition)

3.3 BACKFILLED WALL PENETRATIONS

Cut ULTRASEAL XP to closely fit around penetrations. After installing membrane, trowel a minimum 19 mm (¾") thick fillet of SEAL-X XP around the penetration and the membrane. Extend SEAL-X XP onto the penetration 38 mm (1½") and cover membrane edge (Figure 3.7). In areas where multiple penetrations are close together, it may be impractical to cut ULTRASEAL XP to fit around base of each penetration. Therefore, apply a 19 mm (¾") thick fillet of SEAL-X XP around each penetration and cover the entire surface between the penetrations (Figure 3.8 and 3.9). Extend SEAL-X XP 38 mm (1½") onto the penetrations.

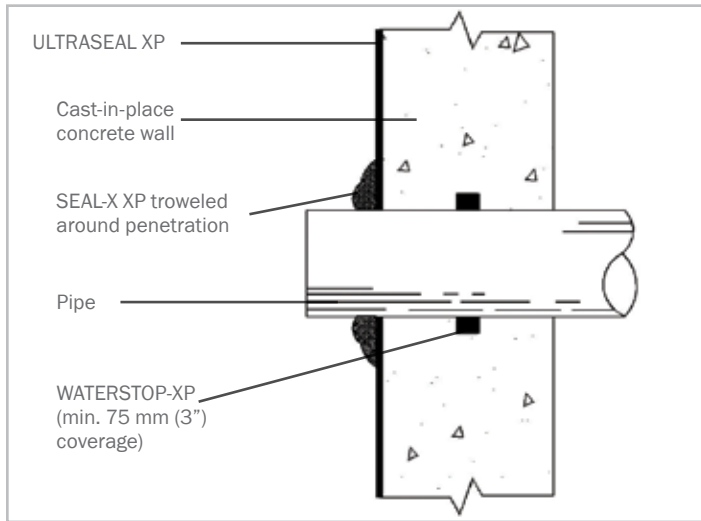

Figure 3.7 – Single penetration cast-in-place wall detail

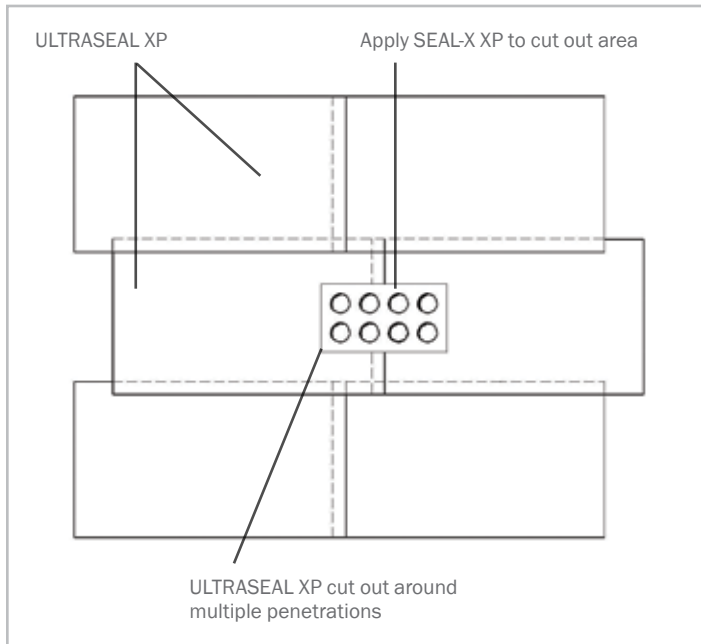

Figure 3.8 – Cut ULTRASEAL XP to fit around penetrations

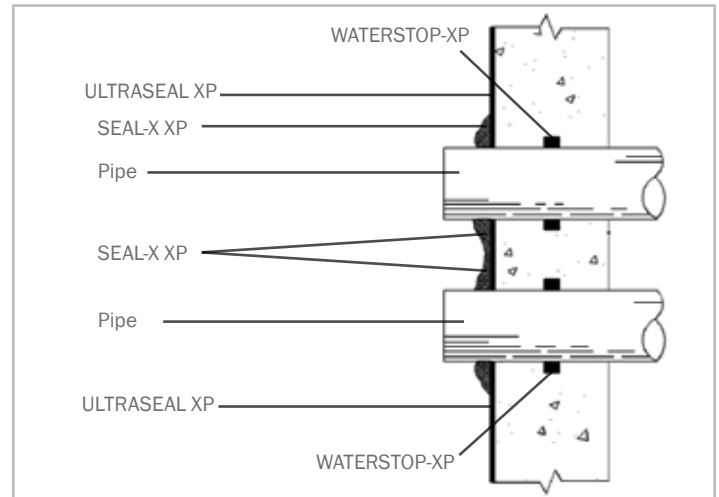

Figure 3.9 – Close multiple penetrations. Trowel SEAL-X XP around and between penetrations

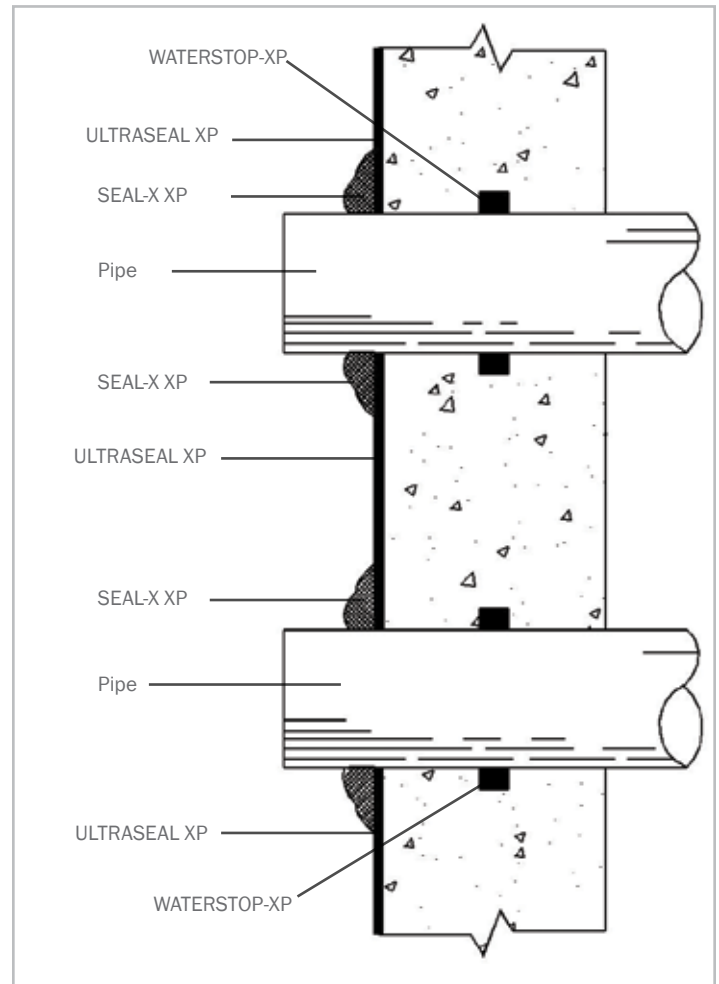

Figure 3.10 – Install ULTRASEAL XP between penetrations with accessibility. Trowel SEAL-X XP around penetrations

ULTRASEAL XP

ACTIVE POLYMER WATERPROOFING SYSTEM

3.4 GRADE TERMINATIONS

Terminate ULTRASEAL XP membrane 300 mm (12") below finished grade elevation with washer-head fasteners maximum 300 mm (12") on center. Install ENVIROSHEET flashing to primed concrete substrate with bottom edge overlapping top edge of ULTRASEAL XP membrane minimum 100 mm (4"). Overlap all roll ends a minimum 100 mm (4") to form a continuous flashing. Height of flashing shall be per project details and specifications. Install a rigid termination bar along top edge of ENVIROSHEET; fastened maximum 300 mm (12") on center. Complete grade termination detail with tooled bead of CETSEAL along the top edge, at all penetrations through the flashing, and all exposed overlap seams. Grade terminations are illustrated in Figures 3.11 and 3.12.

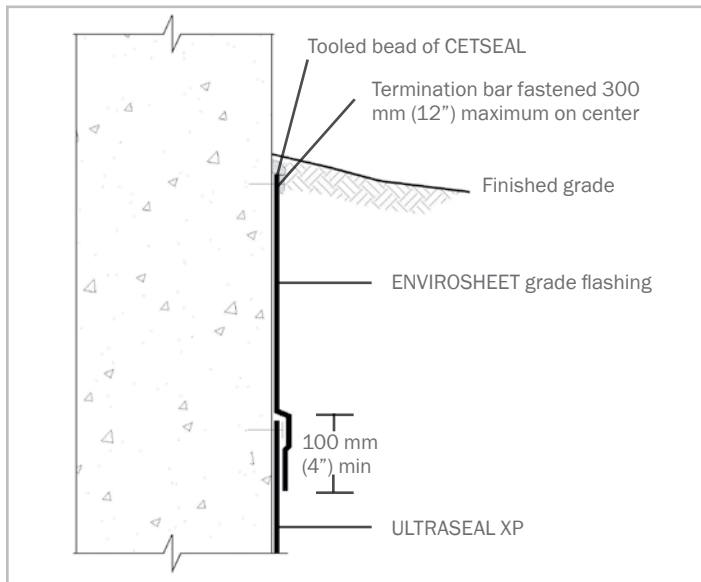

Figure 3.11 – Termination at finished grade

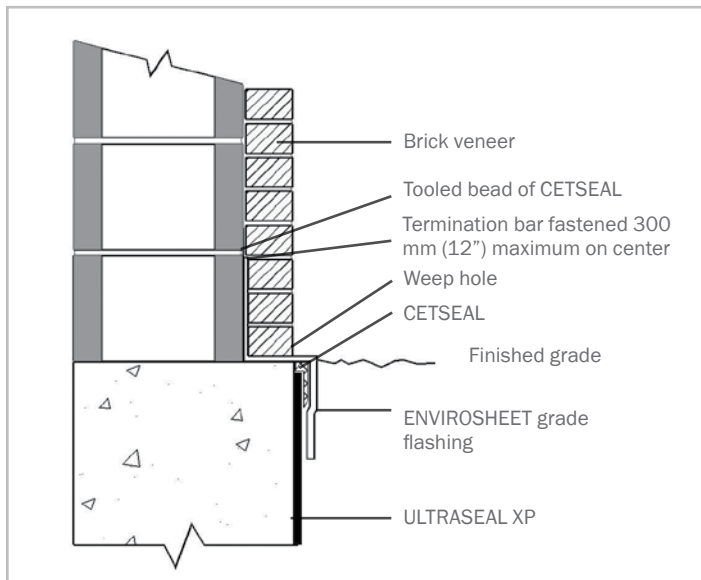

Figure 3.12 – Termination at grade with brick veneer

3.5 MASONRY BLOCK WALLS

ULTRASEAL XP can be used to waterproof masonry block foundation walls. Install ULTRASEAL XP following “Backfilled Wall Installation Guidelines” Section 3, with Seamtape applied to all overlap seams.

SECTION 4

SPECIAL CONDITIONS

4.1 PRECAST CONCRETE CONSTRUCTION

Consult CETCO regarding products and special installation guidelines for precast concrete plank decks, precast earth covered roofs, and precast wall construction.

4.2 CONTAMINATED CONDITIONS

Use ULTRASEAL XP in conditions where the groundwater contains high concentrations of chemicals or saline. These conditions are typically encountered at industrial sites and coastal regions. If groundwater contains strong acids, alkalis, or has a conductivity of 2,500 µmhos/cm or greater (high salt concentration), water samples should be submitted to CETCO for compatibility testing.

For compatibility testing, provide two (2) liters of site groundwater in a clean, unbreakable container. Ship water sample to: CETCO 2870 Forbs Avenue, Hoffman Estates, IL 60192, ATTN: BMG Field Services. Upon analysis, CETCO will provide a written report evaluating the water’s compatibility with ULTRASEAL XP.

IMPORTANT NOTICE

FOR SHOTCRETE, PRECAST CONCRETE, EXPANSION JOINTS AND OTHER APPLICATIONS NOT COVERED IN THIS MANUAL, CONTACT CETCO FOR TECHNICAL ASSISTANCE AND INSTALLATION GUIDELINES.

IMPORTANT NOTICE

Contact CETCO for verification of specification and installation requirements to comply for eligibility of HydroShield Warranty.

LIMITED WARRANTY

The information and data contained herein is believed to be accurate and reliable. Specifications and other information contained herein supersede all previously printed material and are subject to change without notice.

Manufacturer's warranty of installed system is available. Contact seller for terms and sample documents including all limitations.

All goods sold by seller are warranted to be free from defects in material and workmanship.

The foregoing warranty is in lieu of and excludes all other warranties not expressly set forth herein, whether expressed or implied by operation of law or otherwise including but not limited to any implied warranties of merchantability or fitness.

Seller shall not be liable for incidental or consequential losses, damages or expenses, directly or indirectly arising from the sale, handling or use of the goods, or from any other cause relating thereto, and seller's liability hereun-

der in any case is expressly limited to the replacement (in the form originally shipped) of goods not complying with this agreement or at seller's election, to the repayment of, or crediting buyer with, an amount equal to the purchase price of such goods, whether such claims are for breach of warranty or negligence.

Any claim by buyer with reference to the goods sold hereunder for any cause shall be deemed waived by buyer unless submitted to seller in writing within thirty (30) days from the date buyer discovered or should of discovered, any claimed breach.

Materials should be inspected and tested by purchaser prior to their use if product quality is subject to verification after shipment. Performance guarantees are normally supplied by the applicator.

Note: ULTRASEAL XP waterproofing system is not an expansion joint material.



www.cetco.com | contact@cetco.com

UPDATED: JUNE 2016

© 2018 Minerals Technologies Inc. IMPORTANT: The information contained herein supersedes all previous printed versions, and is believed to be accurate and reliable. For the most up-to-date information, please visit www.cetco.com. CETCO accepts no responsibility for the results obtained through application of this product. CETCO reserves the right to update information without notice.



FORM: PM_ULTRASEAL_XP_AM_EN_201606_V5